



# Schneider Electric

## Retail Catalogue

[se.com/ca](https://se.com/ca)

Life Is 

**Schneider**  
Electric 



## Schneider Electric – Life is On: Our Promise

The change in our world is more profound than ever, driven by a new scale and speed of urbanization, digitization, and industrialization. New technologies, enabling for the first time distributed and connected energy, challenge us to redefine the way we live our lives.

We invent technologies that will transform the places where we live, work, and play. With our ingenious design philosophy, we deliver solutions that integrate seamlessly to our environment, supporting the rhythm of our lives, empowering people to do more with less.

As the global leader in energy management and automation, we provide connected technologies that will reshape industries, transform cities, and enrich lives.

At Schneider Electric, we call this Life Is On.

*Jean-Pascal Tricoire*

Chairman & Chief Executive Officer Schneider Electric

# Table of Contents

## HomeLine Product Selection

Introduction to HomeLine Circuit Breakers	4
Circuit Breakers - 1"	5
High Magnetic Breakers	5
Tandem (Space Saver) Circuit Breakers	6
Quad (Space Saver) Circuit Breakers	6
Ground Fault Circuit Breakers	7
Combination Arc Fault Breakers	8
Dual Function Circuit Breakers	8
Hot Tub/Pool/Spa Package	9
Surge Protective Devices	10
Main Circuit Breakers	11
Circuit Breaker Accessories	12
Introduction to HomeLine Loadcentres	13
Key Features	14
Plug-on Neutral Loadcentres	15
Panel Packages	16
Sub Panels - Indoor/Outdoor	17
Main Breaker Loadcentres	18
Loadcentre Accessories	19
<b>Square D Product Selection</b>	
Introduction to QO Circuit Breakers	20
Circuit Breakers - 3/4"	21
High Magnetic Breakers	21
Tandem (Space Saver) Circuit Breakers	21
Ground Fault Circuit Breakers	22
Combination Arc Fault Breakers	23
Dual Function Circuit Breakers	24
Spa packs	25
Plug On Surge Protective Devices	26
Bolt on Main Breakers	27
Circuit Breaker Accessories	28
Introduction to Square D Loadcentres	29
Plug-on Neutral Loadcentres	30
Panel Packages	31
Sub Panels - Indoor/Outdoor	32
Main Breaker Loadcentres	33
300A/400A Loadcentres	34
Generator Panels	35-36

Loadcentre Accessories	37
Introduction to Square D Surge Protection	38
Whole House Surge Protection	39
Home Electronics Protective Devices	40
Introduction to Square D Disconnects Switches	41
General Duty Safety Switches	42
Double Throw Safety Switches	42
Air Conditioner Disconnect	43
Introduction to Square D Pressure Switches	44
Water Pressure Switches	45
Air Pressure Switches	46

## Federal Pioneer Stab-lok Product Selection

Introduction to Stab-lok Circuit Breakers	47
Circuit Breakers - 1/2"	48
Ground Fault Circuit Breakers	48
Arc Fault Circuit	48
Bolt on Main Breakers	48
Circuit Breaker Accessories	49

## Schneider Electric Product Selection

Wiser Energy	50
Mobiya LED Lantern	52

## Application Guides

Electrical Protection for the Whole House	53
Circuit Breaker Application Guide	55-56
Connected Devices	57-58
HomeLine Warranty	59
Square D Warranty	60
Whole House Surge Warranty	61
Residential Products	62

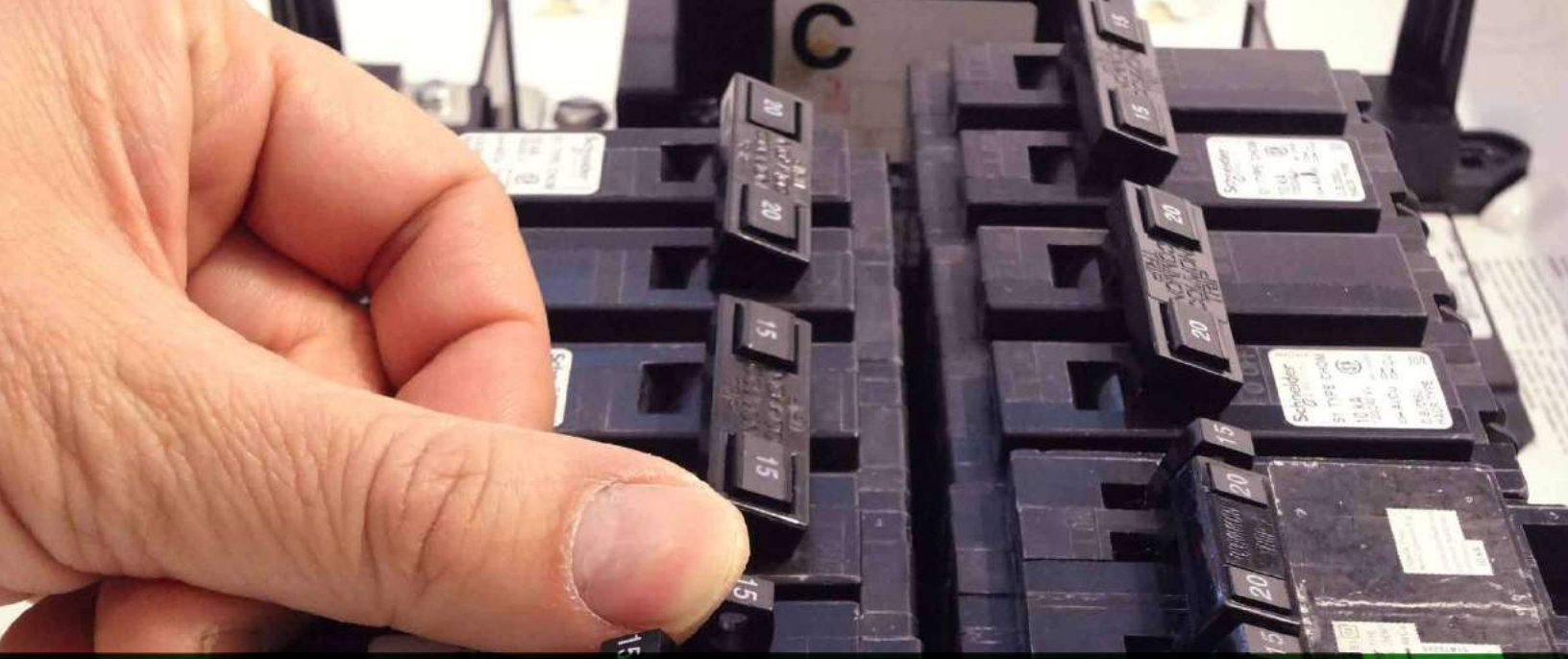

# HomeLine™ Circuit Breakers

## Unsurpassed Qwik-Open Protection

Canadian HomeLine™ circuit breakers provide the high level of protection you expect from Schneider Electric. The industry's best value in circuit protection in a one inch wide industry-standard format for one-pole circuit breakers. HomeLine™ breakers feature Qwik-Open™ circuit breakers, which give homeowners reliable, fast acting circuit protection, a full range of breakers including tandem and quad breakers and the unique limited lifetime warranty.

HomeLine circuit breakers are designed exclusively for the residential market.

### HomeLine™ Circuit Breaker Features:

- Provide overload and short circuit protection.
- Accepts Al/Cu conductors.
- Accepts 60/75°C wire up to 40 A, 75°C wire over 40 A.
- CSA listed for HACR.  
(Heating, air-conditioning and refrigeration equipment).
- Standard – 1" per pole
  - Twin – ½" per pole
  - Quad – ½" per pole
- SWD (switching duty) rated for 1" 15 A and 20 A breakers. Suitable for switching 120 Vac fluorescent lighting loads.
- CSA approved to only install in Canadian HomeLine™ loadcentres.
- Exclusive Qwik-Open™ protection is standard on all 15 A and 20 A circuit breakers—trip reaction within 1/60th of a second.
- Limited Lifetime Warranty.

# Circuit Breaker Product Selection

## Circuit Breaker Selection - 10,000 AIR

Amp Rating	One Pole 120 Vac	Lug Range	Two Pole 240 Vac	Lug Range
15 A	CHOM115CP❶	#14-#8	CHOM215CP	#14-#8
20 A	CHOM120CP❶	#14-#8	CHOM220CP	#14-#8
30 A	CHOM130CP	#14-#8	CHOM230CP	#14-#8
40 A			CHOM240CP	#8-#2
50 A			CHOM250CP	#8-#2
60 A			CHOM260CP	#8-#2
100 A			CHOM2100CP	#4-2/0
150 A			CHOM2150BB	#4-300mcm
200 A			CHOM2200BB	#4-300mcm

❶SWD - Suitable for switching 120 Vac fluorescent lighting loads.

All CHOM 1 & 2 pole breakers CSA listed as HACR type for use with air conditioning, heating and refrigeration.



HomeLine™  
One Pole Breaker  
1 Space Required



HomeLine™  
Two Pole Breaker  
2 Spaces Required



HomeLine™  
Two Pole Breaker 200A  
4 Spaces Required

### FAST FACTS

What is Power?  
Power is the rate of  
doing work measured  
in Watts.  
Watts=Volts x Amps  
1 HP = 746 Watts

# Circuit Breaker Product Selection

Tandem and quad space saver circuit breakers are ideal for adding additional circuits to an existing HomeLine™ panel with limited space.

## Tandem (Space Saver) Circuit Breaker Selection - 10,000 AIR

Amp Rating	2 x 1-pole 120Vac 1 Space Required	Lug Range
15 A & 15 A	<b>CHOMT1515CP</b>	#14-#8
20 A & 20 A	<b>CHOMT2020CP</b>	#14-#8



HomeLine™  
Tandem Breaker  
1 Space Required

## Quad (Space Saver) Circuit Breaker Selection - 10,000 AIR

Amp Rating 1 Pole	Amp Rating 2 Pole	2 One Pole, 1 Two Pole 120/240 Vac	Lug Range
15 A	15 A	<b>CHOMT1515215CP</b>	#14-#8
15 A	20 A	<b>CHOMT1515220CP</b>	#14-#8
15 A	30 A	<b>CHOMT1515230CP</b>	#14 - #8
15 A	40 A	<b>CHOMT1515240CP</b>	#6 - #12 Al / #6 - #14 Cu

Quad breakers have two single pole outer circuits, and one double pole inner circuit with common trip.



HomeLine™  
Quad Breaker  
2 Spaces Required

All CHOM 1 & 2 pole breakers are CSA listed as HACR type for use with air conditioning, heating and refrigeration.



# GFCI Product Selection

The HomeLine™ Ground Fault Circuit interrupter (GFCI) protects people against electrical shocks. GFCI protection is required in wet or damp areas such as bathrooms, kitchens, garages, spas, pools and outdoor receptacles.

## HomeLine™ Ground Fault Breaker Features:

- Provides overload, short circuit and Class A GFI 5mA protection.
- Limited Lifetime Warranty.
- CSA approved to only install in Canadian HomeLine™ loadcentres.



HomeLine™  
One Pole GFI Breaker  
1 Space Required

## GFCI Breakers Selection - 10,000 AIR

Amp Rating	One Pole 120 Vac	Two Pole Common Trip 240 Vac
15 A	<b>CHOM115GFI</b>	<b>CHOM215GFI</b>
20 A	<b>CHOM120GFI</b>	<b>CHOM220GFI</b>
30 A		<b>CHOM230GFI</b>
40 A		<b>CHOM240GFI</b>
50 A		<b>CHOM250GFI</b>

# HomeLine™ Combination Arc Fault and Dual Function Circuit Breakers

Featuring exclusive digital technology, the HomeLine™ Combination Arc Fault Interrupter (CAFI) detects overloads, short circuits and arc-faults. The CAFI technology stops the flow of current when an arc fault is detected to significantly reduce the risk of an electrical fire.

Effective in 2015 the Canadian Electrical Code requires Combination Arc Fault breaker (CAFI) to be installed on most circuits supplying receptacles rated 125Vac max, 15A and 20A. Refer the current CEC for more information.

HomeLine™ Dual Function (DF) circuit breakers combine combination arc fault and ground fault protection in a single device. These breakers meet the Canadian Electrical Code requirements for arc fault protection and offer (Class A - people protection) ground fault protection.

This unique combination saves space in the panel and installation time for the homeowner or contractor, replacing the arc fault breaker and a ground fault receptacle combination.

## HomeLine™ CAFI and DF Circuit Breaker Features:

- CAFI - detects unintended arc faults, overloads and short circuits.
- DF - detects unintended arc faults, ground faults, overloads and short circuits
- Push-to-test button
- Plug-on neutral (new construction) or pig-tail (renovation) designs.
- TIME SAVER diagnostics feature that assists in identifying the type of fault in a circuit.

Function	Amperage	Plug-on Neutral Type		Pig-Tail Type	
		1-Pole	2-Pole	1-Pole	2-Pole
CAFI	15A	CHOM115PCAFI	--	CHOM115CAFI	CHOM215CAFI
CAFI	20A	CHOM120PCAFI	--	CHOM120CAFI	CHOM220CAFI
DF	15A	CHOM115PDF	--	CHOM115DF	--
DF	20A	CHOM120PDF	--	CHOM120DF	--





# HomeLine™ Hot Tub/Pool/Spa Package

Schneider Electric offers a metal enclosure hot tub/pool/spa electrical protection line, the HomeLine™ Hot Tub/Pool/Spa Pack. This pack includes a HomeLine outdoor metallic loadcentre and an installed 50 A ground fault circuit interrupter.

Along with many other features and benefits, the CHOM250GFI 2-pole ground fault circuit breaker protects 2-pole loads against ground and overcurrent faults. The loadcentre and GFCI breaker provide protection for outdoor circuits such as hot tubs, fountains, swimming pools or spas.

## Spa Package Features:

- 50A HomeLine™ 2-pole QWIK-GARD® ground fault circuit breaker (CHOM250GFI) installed in loadcentre CHOM24L70RB protects 120 V and 240 V loads against ground and overcurrent faults.
- Designed for applications up to 50 A 120/240 Vac single-phase and 3-wire with ground.
- Painted, zinc-coated steel outdoor enclosure.
- Top-hinged cover can be padlocked.
- 10,000 A short-circuit current interrupting rating.
- Easy-to-remove steel interior trim.
- CSA certified.
- Ideal for indoor or outdoor applications.
- Warranty: 10 years on enclosure, lifetime of the device on the GFCI when used in a residential installation.



50 A Hot Tub/Pool/Spa Package

## Spa Package Selection (1 Phase, 3 Wire, 120/240 Vac)

Amp Rating	Catalogue Number	Weight (lbs.)	Box Dimensions					
			Height		Width		Depth	
			Inches	mm	Inches	mm	Inches	mm
50 A	<b>CHOME250SPA</b>	6.22	9.36	237	4.88	124	4.00	102

# Plug-on Neutral Whole House Surge Protection

Designed to work exclusively on HomeLine Plug-on Neutral loadcentres, this surge protector is the quickest and easiest to install whole house surge protector. Simply find two empty spaces in a HomeLine loadcentre and connect to the busbar and neutral bar. There is nothing to replace or reset on this device.

It provides electrical whole house surge protection for sensitive electronics, and reduce surges that might otherwise overwhelm plug strips and damage connected household equipment. Provides surge protection for important items such as washers, dryers, refrigerators, stoves, and lighting that plug strips don't protect.

## Features:

- For use on only new HomeLine loadcentres with Plug-on neutral bars.
- 2 Pole Plug-on design is easy and quick to install.
- Green status LED indicates operational status.
- Modes of protection - 3.
- Fusing - individually fused MOVs.
- cULus Listed per UL 1449 Type 1 SPD, CSA C22.2 No. 269.1, C233.1
- Surge Current Rating per Phase 50,000A.
- Short Circuit Current Rating 22,000A.
- 5 year/\$50,000 connected equipment warranty.



CHOM250PSPD

Catalogue Number	Modes of Protection	MCOV	VPR	
			L-N	L-L
CHOM250PSPD	3	150VL-N, 300V L-L	500V	900V

## Surgebreaker Surge Protective Devices

The Homeline Surge breaker Surge Protective Device is designed as a quick plug-on unit for use in Homeline load centers. The SPD requires 2 pole spaces. This unit has 22,500 Amp Maximum Surge Capacity and has a 150 Vac line-to-ground maximum providing protection from electrical surges.

## Features:

- Easy plug-on installation for HomeLine loadcentres.
- LED indicates operational status.
- Designed to protect electrical service and "major household appliances" excluding electronic devices.
- 3 year/\$10,000 connected equipment warranty.



CHOM2175SB

Catalogue Number	Modes of Protection	MCOV	SCCR	SCR
CHOM2175SB	3	150V	22.5kA	22kA

# HomeLine™ Main Circuit Breakers

Standard 22,000/10,000 ampere series short circuit current rating on main breaker panels provides increased application capability. Main breakers are bolt-on for all residential service entrance loadcentres.

## HomeLine™ Main Breaker Features:

- Provides option for padlock in “OFF” position.
- Bolt-on main breaker for HomeLine™ service entrance panels.

## Bolt-on Main Breaker Selection

Ampere Rating	Part Number	kAIC	Lug Range	Frame Size
30 A	QOM30L	10	#12-2/0	QOM1
40 A	QOM40L	10	#12-2/0	QOM1
50 A	QOM50VHL	22	#12-2/0	QOM1
60 A	QOM60VHL	22	#12-2/0	QOM1
70 A	QOM70VHL	22	#12-2/0	QOM1
80 A	QOM80VHL	22	#12-2/0	QOM1
100 A	QOM100VHL	22	#12-2/0	QOM1
125 A	QOM125VHL	22	#12-2/0	QOM1
100 A	QOM2100VHL	22	#4-300mcm	QOM2
125 A	QOM2125VHL	22	#4-300mcm	QOM2
150 A	QOM2150VHL	22	#4-300mcm	QOM2
200 A	QOM2200VHL	22	#4-300mcm	QOM2
225 A	QOM2225VHL	22	#4-300mcm	QOM2

Main Breakers include factory installed handle padlock attachment (padlock QOM main circuit breaker in the 'off' position).



QOM1 Frame Size Main Breaker



QOM2 Frame Size Main Breaker

## Circuit Breaker Wire Sizes

Breaker Type	Ampere Rating	Wire Size (AWG)	
		Aluminum	Copper
CHOM 1 Pole	15-30	#14-8	(2) #14-10
	45-50	#8-2	#8-2
CHOM 2 Pole	15-30	#14-8	#14-8 or (2) #14-10
	35-70	#8-2	#8-2
	80-125	#4-2/0	#4-2/0
CHOM Tandem and Quad	15-30	#14-8	#14-8
CHOM GFI - 1P	15-20	#14-10	#14-10
CHOM GFI - 2P	15-50	#12-4	#14-6



# HomeLine™ Circuit Breaker Accessories

## Accessory Selection

Accessory	Description	Catalogue Number
Handle Attachments		
Handle Tie	Converts any 2 adjacent 1P CHOM circuit breakers to independent trip 2P.	HOM1HT
	Converts any adjacent 1P side by side CHOM Tandem breakers to independent 2P	HOMTHT
Handle blocking device	Attaches to a CHOM 2P breaker for holding the handle in the OFF position.	HOM2HBD
Handle lock	ON or OFF, padlocking HomeLine 1P 15-50A circuit breaker.	HOM1PA
HomeLine handle lock ON or OFF, Padlocking		
	- Handle padlock attachment, for padlocking 1P CAFI, DF, GFI, and EPD HOM breakers in the ON or Off position	HOMELEC1PA
	- Handle padlock attachment, for padlocking 2P CAFI, DF, GFI, and EPD HOM breakers in the ON or Off position	HOMELEC2PALA
	- Handle padlock attachment, for padlocking 2P 15-70A	HOM2PALA
	- Handle padlock attachment, for padlocking 2P 80-125A	HOM2PAHA
	Handle padlock attachment, for padlocking centre poles of CHOM quad breakers in the OFF position	HOMQPA
	Handle lock, OFF for QOM1 50-125A Main Circuit Breaker	QOM1PA
	Handle lock, OFF for QOM2 100-225A Main Circuit Breaker	QOM2PA
Sub-feed Lugs		
	125A 2P plug-on - 2 spaces required	HOML2125
	225A 2P plug-on - 4 spaces required	HOML2225



HOM1HT



HOM1PA



HOM2PALA



HOM2PAVHA



# HomeLine™ Loadcentres

## Features that Outclass the Competition

The quality you expect from Schneider Electric, the industry leader, is built into all HomeLine™ loadcentres.

Canadian HomeLine™ loadcentres are the smart choice for value-minded contractors, remodelers, builders and homeowners. HomeLine™ loadcentres are CSA approved to only accept CHOM breakers.

### Panel Features:

- Straight-in wiring mains design.
- Standard 22,000 ampere short circuit current rating on main breaker.
- Combination slot/Robertson neutral, ground and cover screws.
- Shielded aluminum bus and interior assembly.
- Multiple horizontal ground bar mounting locations (left, right and bottom).
- Backed out neutral screws save labor and installation time.
- 10 Year Warranty.

### FAST FACTS

HomeLine loadcentres was first introduced in North America between 1988 and 1989.

# HomeLine™ loadcentres offer unique features for the value-minded contractors

## Key Features



### Single teardrop positioning hole

Enables single-person installation. The load center can be hung in position and is easily secured with the embossed mounting holes.



### Bolt on main breaker/straight-in wiring

All 100A and 200A panels have a bolt on main breaker for solid connection. Straight-in wiring for main breaker connection saves wire and time - minimize service cable bends.



### Distributed branch neutral

Reduces clutter and simplifies wiring.



### Factory removed branch twist-outs and main breaker K.O.

All HomeLine service entrance loadcentres come with the first two branch twist-outs and the main breaker K.O. (New Feature) factory removed to save installation time.



### Automatic flush adjustment

Cover features a floating, spring-mounted trim providing automatic adjustment. This ensures proper alignment without manual adjustment and speeds up the final installation.



### Painted appliance white

Tub and trim painted white adds a clean look for finished areas and reduces sharp edges for electricians.



### Cover with door

HomeLine™ service entrance loadcentres come with door to cover exposed breakers. Convenient for unfinished basements with no cabinet enclosure.

(Exception: 120 circuit loadcentres)

# Plug-on Neutral (PoN) Panel Packages

HomeLine™ (PoN) panel packages combine a service entrance loadcentre with a selection of breakers including the combination arc fault breakers for the updated 2015 code. The HomeLine™ PoN loadcentres are designed to accept the plug-on neutral (PoN) combination arc fault (CAFI) and dual function (DF) circuit breakers. The PoN CAFI and PoN DF circuit breakers connect directly to the neutral bar of the loadcentre, eliminating the need to attached a separate neutral wire to the neutral bar. The HomeLine™ PoN loadcentres features a fully distributed neutral bar that is versatile enough to accept either pigtail or PoN devices.



- Distributed Neutral Bar**  
 Plug-on Neutral HomeLine™ service entrance loadcentres are engineered to accept the PoN CAFI and DF circuit breakers.



- Faster Installation / Frees Gutter Space**  
 With the elimination of the pigtail wires in the panel the contractor has fewer connections which saves time and frees gutter space for a cleaner look.

## Compare the difference



- Easier Troubleshooting**  
 With a much cleaner look, tracing the destination of wires is easier and inspection of panels easier.

Pigtail Neutral Connections

Plug-on Neutral Connections

## HomeLine Panel Package Selection (1 Phase, 3 Wire, 120/240 Vac)

Main Amp Rating	Number of Circuits		Catalogue Number	Main Wire Size AWG/kcmil AL/Cu	Product Dimensions					
	Standard 1"	Tandem/Quad			Height		Width		Depth	
					Inches	mm	Inches	mm	Inches	mm
100 A	24	48	VP1048PON	#6-2/0	26.04	661	14.25	362	3.75	95
100 A	30	60	VP1060PON	#6-2/0	33.78	858	14.25	362	3.75	95
200 A	30	60	VP2060PON	#4-250	33.78	858	14.25	362	3.75	95
200 A	42	84	VP2084PON	#4-250	39.37	1000	14.25	362	3.75	95

Each Panel Package Includes:

Catalogue Number	1 Pole 15A	15A Tandem	1 Pole 20A	2 Pole 15A	2 Pole 30A	2 Pole 40A	1 Pole 15A CAFI
VP1048PON	6		2		1	1	3
VP1060PON	8		2		1	1	3
VP2060PON	8		2		1	1	6
VP2084PON	8		2		1	1	6



# HomeLine™ Panel Packages

HomeLine™ panel packages combine a service entrance loadcentre with a selection of breakers for easy installation. This panel offers features such as, straight-in main breaker wiring, painted appliance white finish for no sharp edges, drywall markers for accurate installation and a shielded bus design.

## Panel Package Features:

- Expandable loadcentre capacity with the use of tandem and quad breakers.
- CSA approved for vertical, horizontal or inverted mounting.
- Accepts aluminum or copper conductors.
- Distributed neutral bars reduces clutter and simplifies wiring.
- Complete with latch door on the trim, with option for door lock. See page 19 for accessories.



24 Circuit 100A Panel Package

## HomeLine Panel Package Selection (1 Phase, 3 Wire, 120/240 Vac)

Main Amp Rating	Number of Circuits		Catalogue Number	Main Wire Size AWG/kcmil AL/Cu	Product Dimensions					
	Standard 1"	Tandem/Quad			Height		Width		Depth	
					Inches	mm	Inches	mm	Inches	mm
100 A	12	24	<b>VCP1024</b>	#6-2/0	17.92	455	14.25	362	3.75	95
100 A	16	32	<b>VCP1032</b>	#6-2/0	20.92	531	14.25	362	3.75	95
200 A	20	40	<b>VCP2040</b>	#4-250	29.86	758	14.25	362	3.75	95

Each Panel Package includes 2 filler plates



Each Panel Package Includes:

Catalogue Number	1 Pole 15A	15A Tandem	1 Pole 20A	2 Pole 15A	2 Pole 30A	2 Pole 40A
VCP1024		5				
VCP1032		5		1	1	1
VCP2040	10			1	1	1





# HomeLine™ Sub Panels

## HomeLine™ Main Lugs Loadcentres Type 1 Indoor

HomeLine™ sub panels are an ideal solution if your main service panel is full but you want to add multiple circuits to your home. Sub panels do not include a main breaker.

### Indoor Loadcentre Features:

- Install addition circuits using tandem or Quad breakers.
- 2, 4 and 6 circuit sub panels are painted grey.
- Accepts aluminum or copper conductors.



6 Space Sub Panel

### Main Lugs Loadcentre Selection (1 Phase, 3 Wire, 120/240 Vac)

Bus Amp Rating	Number of Circuits		Catalogue Number	Main Wire Size AWG/kcmil AL/Cu	Product Dimensions					
	Standard 1"	Tandem/Quad			Height		Width		Depth	
					Inches	mm	Inches	mm	Inches	mm
70 A	2	4	<b>CHOM24L70S</b> ①	#12-3 #14-4	9.30	236	4.81	122	3.19	81
100 A	6	12	<b>CHOM612L100S</b> ①	#8-1	12.57	319	8.88	226	3.80	97
125 A	4	8	<b>CHOM48L125GC</b>	#4-2/0	14.80	376	8.88	226	3.80	97
125 A	8	16	<b>CHOM816L125GC</b>	#6-2/0	17.92	455	14.25	362	3.75	95
125 A	12	24	<b>CHOM1224L125GC</b>	#6-2/0	17.92	455	14.25	362	3.75	95
125 A	16	32	<b>CHOM1632L125GC</b>	#6-2/0	26.04	661	14.25	362	3.75	95
125 A	24	48	<b>CHOM2448L125GC</b>	#6-2/0	26.04	661	14.25	362	3.75	95
125 A	30	60	<b>CHOM3060L125GC</b>	#6-2/0	33.78	858	14.25	362	3.75	95
225 A	30	60	<b>CHOM3060L225GC</b>	#6-250	33.78	858	14.25	362	3.75	95
225 A	42	84	<b>CHOM4284L225GC</b>	#6-250	39.37	1000	14.25	362	3.75	95

① Substitute "S" with "F" at end of part number for Flush cover panel

## HomeLine™ Main Lugs Loadcentres Type 3R Outdoor

### Outdoor Loadcentre Features:

- Type 3R outdoor enclosures - painted grey.
- Enclosures are CSA certified for vertical mounting only.
- Additional hubs on page 19.



2 Space Outdoor Panel

### Outdoor Main Lugs Loadcentre Selection (1 Phase, 3 Wire, 120/240 Vac)

Bus Amp Rating	Number of Circuits		Catalogue Number	Main Wire Size AWG/kcmil AL/Cu	Product Dimensions					
	Standard 1"	Tandem/Quad			Height		Width		Depth	
					Inches	mm	Inches	mm	Inches	mm
70 A	2	4	<b>CHOM24L70RB</b>	#12-3Al/#14-4Cu	9.38	238	4.88	124	4.00	102
100 A	6	12	<b>CHOM612L100RB</b>	#8-1	12.65	321	8.88	226	4.27	108
125 A	4	8	<b>CHOM48L125GRB</b>	#12-2/0Al/#14-2/0Cu	14.80	376	8.88	226	4.27	108
125 A	8	16	<b>CHOM816L125GRB</b>	#6-2/0	18.92	481	14.75	375	4.52	115
125 A	12	24	<b>CHOM1224L125GRB</b>	#6-2/0	18.92	481	14.75	375	4.52	115

# HomeLine™ Main Breaker Only Loadcentres

This service entrance panel is connected to the electrical meter and distributes electricity throughout the home. Each is equipped with a factory installed main circuit breaker, which serves as the main disconnect to turn off power to the loadcentre.

## Main Breaker Loadcentre Features:

- Factory installed main breaker.
- Suitable for surface or flush mounting.
- CSA approved for vertical, horizontal or inverted mounting.
- Install additional circuits using tandem or quad circuit breakers.
- Distributed neutral reduces clutter and simplifies wiring.
- Painted appliance white.



24 Circuit Main Breaker Only Panel

## Main Breaker Loadcentre Selection (1 Phase, 3 Wire, 120/240 Vac)

Main Amp Rating	Number of Circuits		Catalogue Number	Main Wire Size AWG/kcmil AL/Cu	Product Dimensions					
	Standard 1"	Tandem/ Quad			Height		Width		Depth	
					Inches	mm	Inches	mm	Inches	mm
Factory Installed Main Circuit Breaker - QOM1 Main Frame Size										
60 A	12	24	<b>CHOM1224M60GC</b>	#6-2/0	17.92	455	14.25	362	3.75	95
60 A	16	32	<b>CHOM1632M60GC</b>	#6-2/0	20.92	531	14.25	362	3.75	95
100 A	12	24	<b>CHOM1224M100GC</b>	#6-2/0	17.92	455	14.25	362	3.75	95
100 A	16	32	<b>CHOM1632M100GC</b>	#6-2/0	20.92	531	14.25	362	3.75	95
100 A	24	48	<b>CHOM2448M100GC</b>	#6-2/0	26.04	661	14.25	362	3.75	95
100 A	30	60	<b>CHOM3060M100GC</b>	#6-2/0	33.78	858	14.25	362	3.75	95
125 A	24	48	<b>CHOM2448M125GC</b>	#6-2/0	26.04	661	14.25	362	3.75	95
125 A	30	60	<b>CHOM3060M125GC</b>	#6-2/0	33.78	858	14.25	362	3.75	95
Factory Installed Main Circuit Breaker - QOM2 Main Frame Size										
150 A	20	40	<b>CHOM2040M150GC</b>	#4-250	29.86	758	14.25	362	3.75	95
150 A	30	60	<b>CHOM3060M150GC</b>	#4-250	33.78	858	14.25	362	3.75	95
150 A	42	84	<b>CHOM4284M150GC</b>	#4-250	39.37	1000	14.25	362	3.75	95
200 A	30	60	<b>CHOM3060M200GC</b>	#4-250	33.78	858	14.25	362	3.75	95
200 A	42	84	<b>CHOM4284M200GC</b>	#4-250	39.37	1000	14.25	362	3.75	95
200 A	60	120	<b>CHOM60120M200GC</b> ⓘ	#4-250	48.50	1232	14.25	362	3.75	95

ⓘ Does not include a door. Order kit #CHOMDK602 for door.

# HomeLine™ Loadcentres Accessories

## Accessory Selection

Accessory	Description	Catalogue Number
Filler Plates	Fills branch breaker openings in cover	CHOMFPCP
Lock Kits	For use with type 1 Canadian HomeLine Loadcentres.	PK6FL
Interchangeable Hubs	Conduit Size - Type B Hub	
	Closing Plate	BCAP
	3/4"	B-075
	1"	B-100
	1 1/4"	B-125
	1 1/2"	B-150
	2"	B-200
	2 1/2"	B-250
Replacement Covers	CHOM24L70F *	4055800701
	CHOM48L125GC	4055844801
	CHOM48L125GRB	4056314601
	CHOM612L100S *	4055801702
	CHOM612L100F *	4055801801
	CHOM612L100RB	4055342450
	CHOM816M100GRB	4056317850
	CHOM1224M100GRB	4056319050
	CHOM2040M200GRB	4056319050
	CHOM 8-16,12-24 ML-MB loadcentres	CHOMC12UC
	CHOM 16-32 125A, 24-48 ML-MB loadcentres	CHOMC24UC
	CHOM 30-60 100-125A MB loadcentres	CHOMC30U125C
	CHOM 30-60 150-225A ML-MB loadcentres	CHOMC30UC
	CHOM 42-84 ML-MB loadcentres	CHOMC42UC
	CHOM 20-40 MB loadcentres	CHOMC20UC
	CHOM 60-120 MB loadcentres	CHOMC60UC
	Door Kit for CHOM60120M200GC	CHOMDK602



CHOMFPCP



PK6FL



BCAP



B150



CHOMC24UC

\* Cover with no door



# Square D QO™ Circuit Breakers

## QO™ Premium quality designed for lifetime value

QO™ Circuit Breakers provide the high level of protection you expect from Square D.

The exclusive QO™ Visi-Trip™ instantly identifies a tripped circuit breaker with a red indicator window. When a QO™ Visi-Trip™ circuit breaker trips, the handle snaps to a midpoint position between “OFF” and “ON” and a highly visible, red indicator easily identifies the tripped breaker.

### QO™ Circuit Breaker Features:

- Limited lifetime warranty.
- Exclusive Visi-Trip™ indicator.
- Plug-on design, easy to install.
- Quick make - quick break mechanism.
- Trip reaction within 1/60th of a second.
- Single Pole 15 A and 20 A breakers are Switching Duty Rated (SWD). SWD - Suitable for switching 120 Vac fluorescent lighting loads.
- Option for padlocking breaker in “ON” or “OFF” position.
- Slot/Robertson screws for wire termination.
- HACR type for use with air conditioning, heating and refrigeration equipment having motor group combinations and marked for use with HACR type circuit breakers. (Except for QO2100)

### FAST FACTS

QO™ stands for Qwik-Open. They are fastest tripping circuit breakers at 1/60th of a second.

# Circuit Breaker Product Selection Guide

## Plug-On Circuit Breakers Selection - 10,000 AIR

Amp Rating	One Pole 120 Vac	Two Pole 240 Vac
10 A	QO110	
15 A	QO115CP①②	QO215CP②③
20 A	QO120CP①②	QO220CP②③
25 A	QO125CP②	QO225CP②③
30 A	QO130CP②	QO230CP②③
40 A	QO140CP②	QO240CP②③
50 A		QO250CP②③
60 A		QO260CP②③
70 A		QO270CP②③
100 A		QO2100②③
125 A		QO2125②③

- ①SWD - Suitable for switching 120 Vac fluorescent lighting loads.
- ②HACR type for use with air conditioning, heating and refrigeration.
- ③Double Pole 15 A-30 A breakers have ONE rail clip, 40 A and above have TWO rail clips.



QO One Pole Breaker  
1 Space Required

## High Magnetic Breakers Selection

Amp Rating	One Pole 120 Vac
15 A	QO115HM①②
20 A	QO120HM①②

High magnetic breakers are recommended for applications where high initial inrush current may occur.



QO Two Pole Breaker  
2 Spaces Required

## Tandem (Space Saver) Circuit Breakers Selection - 10,000 AIR

Amp Rating	One Pole 120 Vac 1 Space Required	Two Pole 120/240 Vac 2 Spaces Required
15 A & 15 A	QO1515CP②	Order Two Tandem Circuit Breakers and Handle Tie Catalogue #QOTHT
20 A & 20 A	QO2020CP②	
15 A & 30 A	QO1530②	
20 A & 15 A	QO2015②	
15 A & 20 A	QO1520CP②	
20 A & 30 A	QO2030②	
30 A & 15 A	QO3015②	
30 A & 20 A	QO3020②	
30 A & 30 A	QO3030②	

- ②HACR type for use with air conditioning, heating and refrigeration

Tandem (Space Save) circuit breakers are ideal for adding additional circuits to an existing panel with limited space.



QO Tandem Breaker  
1 Space Required

# QO™ Ground Fault Circuit Breakers

QO™ Ground Fault Circuit Interrupters (GFCIs) combine the same level of overcurrent circuit protection as standard QO™ Circuit Breakers, with ground fault protection for personal protection against electrical shock.

GFCI protection is required in wet or damp areas such as bathrooms, kitchens, garages, spas, pools and outdoor receptacles. Do not connect to more than 250 feet of load conductor for the total one-way run to prevent nuisance tripping.

## QO™ Ground Fault Circuit Breaker Features:

- Provides overload and short circuit protection combined with Class A ground fault protection.
- Class A denotes a ground fault that will trip when a fault current to ground is 5 milliamperes or more for people protection.
- Exclusive Visi-Trip™ red indicator.
- Yellow push to test button.
- Provides option for padlock in “ON” or “OFF” position.

## Plug-On Ground Fault Circuit Breakers Selection

Amp Rating	One Pole 120 Vac		Two Pole Common Trip 240 Vac
	10,000 AIR	22,000 AIR	10,000 AIR
15 A	<b>QO115GFICP</b>	<b>QO115VHGFI</b>	<b>QO215GFICP</b>
20 A	<b>QO120GFICP</b>	<b>QO120VHGFI</b>	<b>QO220GFICP</b>
25 A	<b>QO125GFI</b>	<b>QO125VHGFI</b>	<b>QO225GFI</b>
30 A	<b>QO130GFI</b>	<b>QO130VHGFI</b>	<b>QO230GFICP</b>
40 A			<b>QO240GFICP</b>
50 A			<b>QO250GFICP</b>

## Plug-On EPD with 30 mA Sensitivity GFCI Breakers Selection

Amp Rating	One Pole 120 Vac	Two Pole Common Trip 240 Vac
	10,000 AIR	10,000 AIR
15 A	<b>QO115EPD</b>	<b>QO215EPD</b>
20 A	<b>QO120EPD</b>	<b>QO220EPD</b>
30 A		<b>QO230EPD</b>
40 A		<b>QO240EPD</b>
50 A		<b>QO250EPD</b>

Designed to protect equipment such as heat trace from damage (Class B per ICES-003), the ground-fault protection level is 30 mA.

The CEC allows the use of an EPD for heat trace, to prevent freezing of pipes, rain gutters, etc. Other applications include protection of equipment such as well pumps and other electrical equipment in the home or garage.



QO One Pole GFI Breaker  
1 Space Required



QO Two Pole GFI Breaker  
2 Spaces Required

## FAST FACTS

Square D warrants its circuit breakers for the lifetime of the Square D loadcentre in which it is installed.

# QO™ Combination Arc Fault Circuit Breakers

Beginning in 2015, the Canadian Electrical code will require the use of Combination Arc Fault Circuit Interrupters (CAFI) in most branch circuit supplying 125V receptacles rated 20A or less. Square D CAFI breakers are available in both pigtail and plug-on neutral formats, 1 pole/2 pole, and 15A/20A versions.

## Square D Combination Arc Fault Circuit Breaker Features:

- Detects unintended arc faults, overloads and short circuits.
- White push to test button.
- Exclusive Visi-Trip™ red indicator.
- Plug-on CAFI version helps minimize installation time by reducing the number of wires.
- The Plug-on CAFI breaker can only be installed in Square D Plug-on neutral ready loadcentre.
- Saves time - equipped with TIME SAVER diagnostics feature that assists in identifying the type of fault in a circuit.



## Pigtail Neutral CAFI Selection

Ampere Rating	One Pole 120 Vac	Two Pole Common Trip 240 Vac	One Pole 120 Vac	Two Pole Common Trip 240 Vac
	10,000 AIR	10,000 AIR	22,000 AIR	22,000 AIR
15 A	<b>QO115CAFI</b>	<b>QO215CAFI</b>	<b>QO115VHCAFI</b>	<b>QO215VHCAFI</b>
20 A	<b>QO120CAFI</b>	<b>QO220CAFI</b>	<b>QO120VHCAFI</b>	<b>QO220VHCAFI</b>

## Plug-on Neutral CAFI Selection

Ampere Rating	One Pole 120 Vac	Two Pole Common Trip 240 Vac	One Pole 120 Vac	Two Pole Common Trip 240 Vac
	10,000 AIR	10,000 AIR	22,000 AIR	22,000 AIR
15 A	<b>QO115PCAFI</b>		<b>QO115VHPCAFI</b>	
20 A	<b>QO120PCAFI</b>		<b>QO120VHPCAFI</b>	



## TIME SAVER Diagnostics

All Square D QO™ combination arc fault circuit breakers come with a TIME SAVER diagnostics feature that assists in identifying the type of fault that has occurred when the breaker has tripped.

- Requires no tools - easy to use.
- Saves money and time.
- How to use: turn off the circuit breaker, HOLD DOWN the Push-to-test button, and then turn the circuit breaker back on. Use the chart below to determine fault

<b>Trips Instantly (Less than 1 Second)</b>	<b>Fault to Ground</b> - Arcing to Ground - Grounded neutral - Shared neutral - Ground Fault
<b>Trips at 2 Seconds</b>	<b>Arc Fault</b> - Parallel Arc Fault - Series Arc Fault
<b>Trips at 5 Seconds</b>	<b>Procedure Complete</b> - No Fault - Thermal Overload - Short Circuit



# QO™ Dual Function Circuit Breakers

Square D Dual Function circuit breakers combine combination arc fault and ground fault protection in a single device. The dual function circuit breaker meets the 2015 Canadian Electrical code requirements for combination arc fault protection in the home, while also offering (Class A - people protection) ground fault protection.

This unique combination saves space in the panel and installation time for the homeowner or contractor, replacing the arc fault breaker and a ground fault receptacle combination. Ideal for the bedroom and bathroom, where one dual function breaker can arc fault protect the bedroom and ground fault the en suite bathroom. Another application is an outdoor receptacle where the dual function breaker can provide arc fault and ground fault protection inside the home instead of exposed to the outdoor weather. With the built in TIME SAVER diagnostics feature, trouble shooting a fault is easier and faster.

## Square D™ Dual Function Circuit Breaker Features:

- Detects unintended arc faults, ground faults, overloads and short circuits.
- Purple push to test button.
- Exclusive Visi-Trip™ red indicator.
- Offered in both pigtail and non pigtail versions.
- Plug-on version helps minimize installation time by reducing the number of wires.
- Saves time - equipped with TIME SAVER diagnostics feature that assists in identifying the type of fault in a circuit.

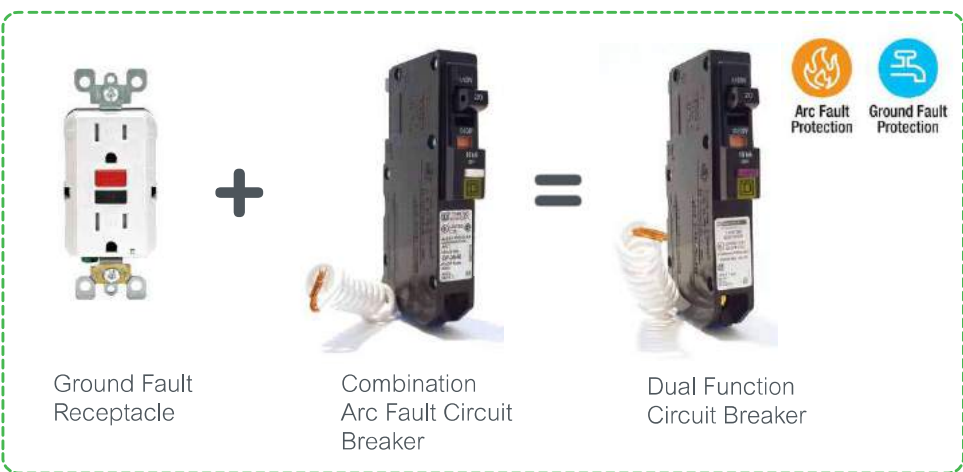

### Pigtail Neutral Selection

Ampere Rating	One Pole 120 Vac	One Pole 120 Vac
	10,000 AIR	22,000 AIR
15 A	QO115DF	QO115VHDF
20 A	QO120DF	QO120VHDF

### Plug-on Neutral Selection

Ampere Rating	One Pole 120 Vac	One Pole 120 Vac
	10,000 AIR	22,000 AIR
15 A	QO115PDF	QO115VHPDF
20 A	QO120PDF	QO120VHPDF



# Square D Hot Tub/Pool/Spa Pack

Selecting an outdoor loadcentre for a hot tub, pool or spa has never been easier. Choose any of the Square D QO™ Hot Tub/Pool/Spa Packs that includes a QO™ Type 3R non-metallic loadcentre and a 20, 30, 40, 50 A or 60 A GFCI.

These GFI products provide protection and switching for outdoor circuits such as hot tubs, fountains, swimming pools or spas. For contractors, remodelers and homeowners requiring a durable outdoor loadcentre and GFCI, the Square D Hot Tub/Pool/Spa Pack will meet their needs.

## QO™ Spa Features:

- Includes 20 - 60 Amp 2-pole QO™ GFCI.
- Exclusive VISI-TRIP® Indicator quickly identifies tripped circuit breaker.
- Polymer, compact Type 3R outdoor enclosure will not rust.
- Side hinged door for easy access.
- Lockable door.
- 10,000 ampere short circuit current rating.
- Ideal for indoor or outdoor applications.



50 A Spa Pack

## Spa Pack Selection (1 Phase, 3 Wire, 120/240 Vac)

Amp Rating	Catalogue Number	Weight (lbs.)	Box Dimensions					
			Height		Width		Depth	
			Inches	mm	Inches	mm	Inches	mm
20 A	CQOE220GFINM	2.7	9.80	245	6.52	165	3.90	99
30 A	CQOE230GFINM							
40 A	CQOE240GFINM							
50 A	CQOE250GFINM							
60 A	CQOE260GFINM①							

① 2 Wire 240 V only. No neutral connection on GFI breaker.

Enclosure only part number: CQO24L60NRNM

## Dimensions

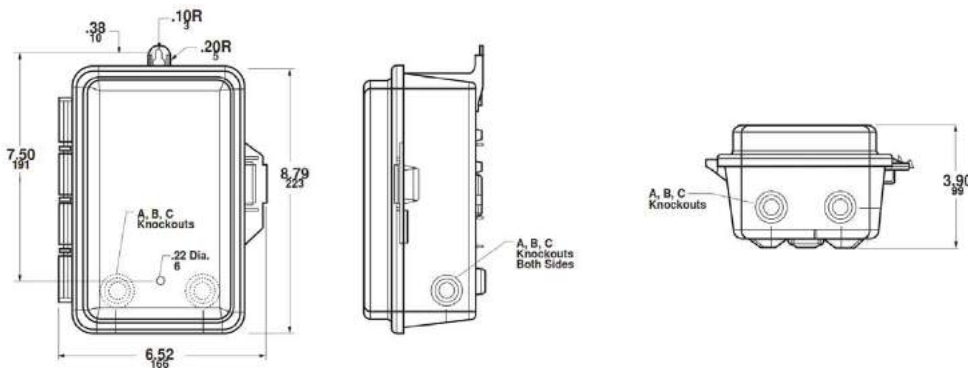

## FAST FACTS

Spa Packs must be located at least 3m (10ft.) away from the hot tub, pool or spa.

# Plug-On Whole House Surge Protection

Designed to work exclusively on Square D Plug-on Neutral loadcentres, this surge protector is the quickest and easiest to install whole house surge protector. Simply find two empty spaces in a Square D loadcentre and connect to the busbar and neutral bar. There is nothing to replace or reset on this device.

It provides electrical whole house surge protection for sensitive electronics, and reduce surges that might otherwise overwhelm plug strips and damage connected household equipment. Provides surge protection for important items such as washers, dryers, refrigerators, stoves, and lighting that plug strips don't protect.

## Features:

- For use on only new Square D loadcentres with Plug-on neutral bars.
- 2 Pole Plug-on design is easy and quick to install.
- Green status LED indicates operational status.
- Modes of protection - 3.
- Fusing - individually fused MOVs.
- cULus Listed per UL 1449 Type 1 SPD, CSA C22.2 No. 269.1, C233.1
- Surge Current Rating per Phase 50,000A.
- Short Circuit Current Rating 22,000A.
- Warranty is \$50,000, 5 years.



CQO250PSPD

Catalogue Number	Modes of Protection	MCOV	VPR	
			L-N	L-L
CQO250PSPD	3	150VL-N, 300V L-L	500V	900V

## Plug On Surge Protective Devices

Designed to work exclusively on Square D loadcentres, the Surgebreaker® surge protectors are easy to install plug on units that installs like a standard circuit breaker. There is nothing to replace or reset on this device. Secondary Surge protectors may not protect solid state or electronic equipment from all lightning induced or other large power surges.

## Features:

- Helps protect wiring and major appliances from damage caused by most external power surges.
- 2 Pole Plug-on design is easy and quick to install in any QO® loadcentre.
- Green status LED indicates operational status.
- cULus Listed per UL 1449 3rd edition Type 2 SPD, CSA C22.2 No. 8-M1986, C233.1-87.
- Warranty is \$10,000, 3 years.



QO2175SB

Catalogue Number	Modes of Protection	MCOV	SCCR	SCR
QO2175SB	3	150V	22.5kA	22kA

# QO™ Main Circuit Breakers

QO™ Main breakers are bolt-on for all residential service entrance loadcentres. Standard 22,000/10,000 ampere series short circuit current rating on main breaker panels provides increased application capability.

## QO™ Main Breaker Features:

- Provides option for padlock in “OFF” position.
- Bolt-on main breaker for Square D service entrance panels.

## Bolt on Main Breaker Selection

Ampere Rating	Part Number	kAIC	Lug Range	Frame Size
30 A	<b>QOM30L</b>	10	#12-2/0	QOM1
40 A	<b>QOM40L</b>	10	#12-2/0	QOM1
50 A	<b>QOM50VHL</b>	22	#12-2/0	QOM1
60 A	<b>QOM60VHL</b>	22	#12-2/0	QOM1
70 A	<b>QOM70VHL</b>	22	#12-2/0	QOM1
80 A	<b>QOM80VHL</b>	22	#12-2/0	QOM1
100 A	<b>QOM100VHL</b>	22	#12-2/0	QOM1
125 A	<b>QOM125VHL</b>	22	#12-2/0	QOM1
100 A	<b>QOM2100VHL</b>	22	#4-300mcm	QOM2
125 A	<b>QOM2125VHL</b>	22	#4-300mcm	QOM2
150 A	<b>QOM2150VHL</b>	22	#4-300mcm	QOM2
200 A	<b>QOM2200VHL</b>	22	#4-300mcm	QOM2
225 A	<b>QOM2225VHL</b>	22	#4-300mcm	QOM2

Main Breakers include factory installed handle padlock attachment (padlock QOM main circuit breaker in the ‘off’ position).



QO 100A Bolt On Main Breaker (QOM1 Frame Size)



QO 200A Bolt On Main Breaker (QOM2 Frame Size)

## Circuit Breaker Wire Sizes

Breaker Type	Ampere Rating	Wire Size (AWG)	
		Aluminum	Copper
QO	10-30	#14-8	(1) #14-8 OR (2)#14-10
	35-70	#8-2	#8-2
	80-125	#12-2/0	#12-2/0
QO Tandem	15-20	#12-8	#14-8
QO-GFI	15-30	#12-8	#14-8
	40,50,60	#12-4	#14-6



# QO™ Circuit Breaker Accessories

## Accessory Selection

Accessory	Description	Catalogue Number
Handle Tie	Converts any two adjacent 120/240Vac single pole QO breakers to independent trip two pole.	QO1HTCP
	Converts any two adjacent 120/240Vac single pole side-by-side Tandem breakers to independent trip two pole.	QOTHT
Handle Lock-Off	Clamp for holding QO single pole handle in "ON" or "OFF" position.	QO1LO
	Clamp for holding QO, either 1,2,or 3 pole breaker handles in "ON" or "OFF" position.	HLO-1CP
Handle Padlock Attachment	For padlocking single pole QO breaker in "ON" or "OFF" position.	
	Loose Attachment	QOHPL
	Fixed Attachment	QO1PA
	For padlocking single pole side-by-side QO Tandem breaker in "ON" or "OFF" position.	QOTHPA
	For 2 and 3-pole QO breakers which require padlocking in either "ON" or "OFF" position.	
	Loose Attachment	QO1HPL
	Fixed Attachment.	QO1PL
	For padlocking QOM main circuit breakers in "OFF" 50-125A.	QOM1PA



QO1HTCP



QOTHT



QO1LO



HLO-1CP



QOHPL



QOTHPA



QO1HPL

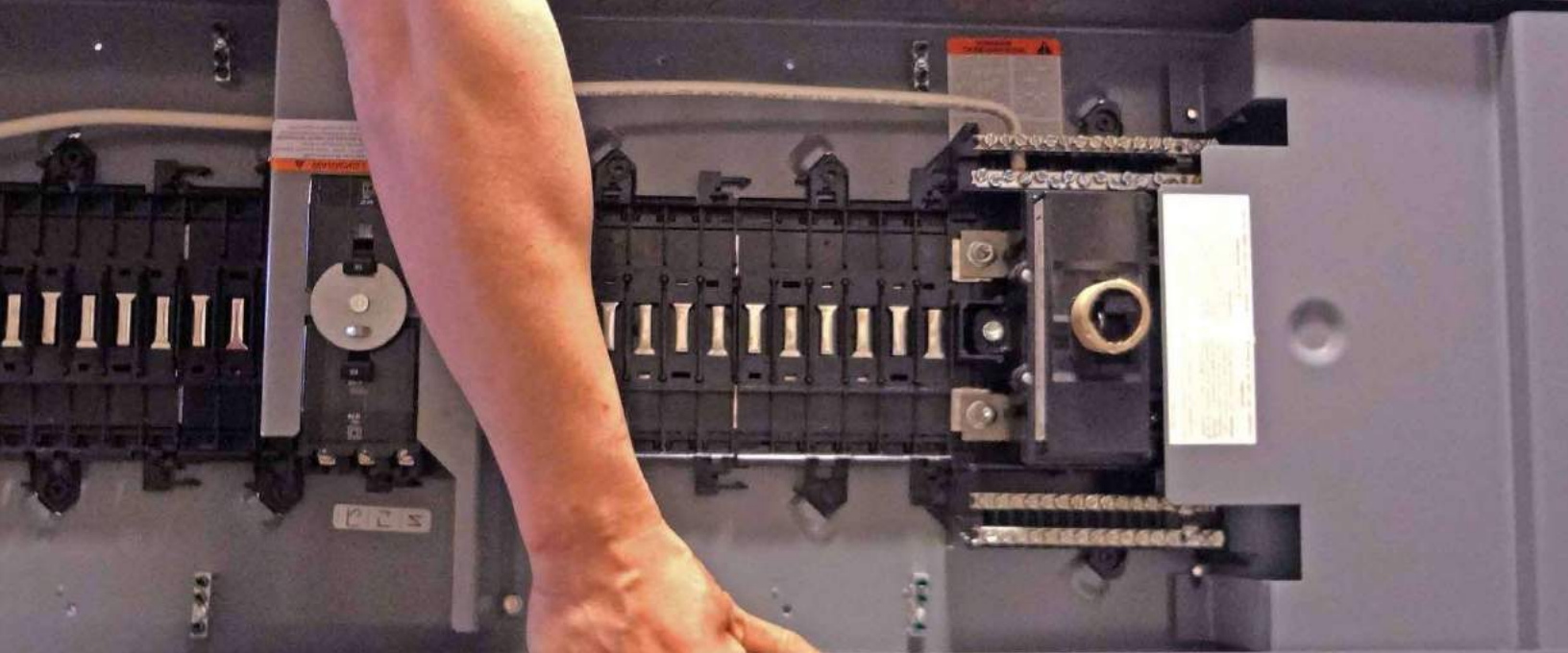

# Square D QO™ Loadcentres

## The Choice of Professionals

Square D service entrance loadcentres feature the rugged design, high quality and proven performance that residential, multi-residential and commercial applications demand, making Square D circuit breakers and loadcentres, the electrical contractors' first choice.

Square D loadcentres are backed by a Lifetime Warranty.

### Panel Features:

#### Quality and Safety

- Accepts QO™ breakers that trip within 1/60th of a second.
- Lifetime limited warranty.
- Straight-in mains design minimized cable bends, cutting waste and saving time.
- Shielded low profile copper bus bar provides added electrical safety against incidental contact.

#### Innovation and Convenience

- Plug-on neutral loadcentre accepts both pigtail and plug-on neutral CAFI.
- Exclusive Visi-Trip® indicator to easily identify a tripped breaker.
- Tandem breakers allow you to easily expand the loadcentre capacity.
- Bolt-on main breaker comes standard on all residential Square D panel packages.
- Combination flush/surface cover with door included.
- CSA approved for vertical, horizontal or inverted mounting.
- Backed out neutral screws save labor and installation time.

# Square D Plug-on Neutral Loadcentres

The Square D plug-on neutral loadcentres are designed to accept the plug-on (pigtail less) combination arc fault circuit breakers. The plug-on combination arc fault circuit breakers connect directly to the neutral bar of the loadcentre, eliminating the need to attached a separate neutral wire to the neutral bar. The Square D loadcentres features a fully distributed neutral bar that is versatile enough to accept either pigtail or pigtail less arc fault breaker or ground fault breaker.

## Compare the difference

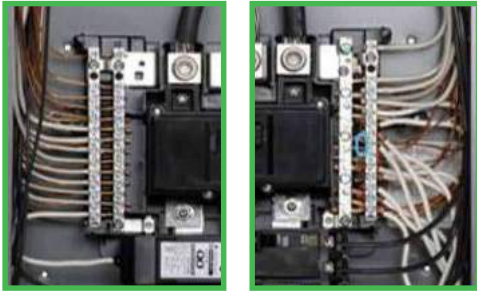

Plug-on Neutral Connections

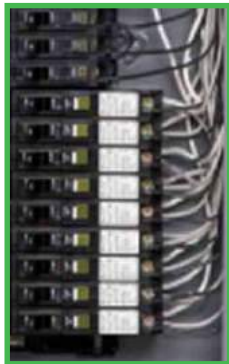

Pigtail Neutral Connections

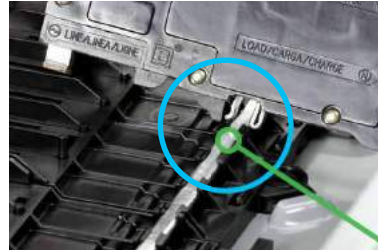

Plug-on Neutral Ready



- Easier Troubleshooting**  
 With a much cleaner look, tracing the destination of wires is easier and inspection of panels easier.
- TIME SAVER Diagnostics**  
 Simple 5 seconds test to assist in identifying the type of fault in a circuit.
- Faster Installation / Frees Gutter Space**  
 With the elimination of the pigtail wires in the panel the contractor has fewer connections which saves time and frees gutter space for a cleaner look.

- Bolt on main breaker** - all 100A and 200A panels have bolt on main breakers for solid connection. Straight-in wiring for main breaker connection saves wire and time - minimize service cable bends. New feature: Main breaker K.O. are now factory removed to save install time.



- Plated copper bus** — one-piece copper bus provides exceptional conductivity and is plated to ensure superior performance and durability



- 180° rotation** - for top, bottom or side feed — improves application flexibility



- Backed out neutral screws** - save labor and installation time.



# Square D Qwikpak® Panel Packages

Square D Panel Packages combine a service entrance main breaker loadcentre and a selection of QO™ circuit breakers in a convenient package for quick installation. This panel package is ready to be installed as a replacement for an older fuse box or to upgrade from an older breaker panel.

For added protection from damage, the trim is packaged in a separate carton in the package.

## Qwikpak Panel Package Features:

- Plug-on neutral ready.
- Expandable loadcentre capacity with the use of QO™ tandem breakers.
- CSA approved for vertical, horizontal or inverted mounting.
- Tin plated copper bus bars
- Accepts aluminum or copper conductors.
- Lifetime limited Warranty.



32 Circuit 100A Panel Package

## Square D Panel Package Selection (1 Phase, 3 Wire, 120/240 Vac)

Main Amp Rating	Number of QO Circuits		Catalogue Number	Main Wire Size AWG/kcmil AL/Cu	Product Dimensions					
					Height		Width		Depth	
	Standard	Tandem			Inches	mm	Inches	mm	Inches	mm
100 A	24	48	<b>QP24100</b>	#4-2/0	21.00	533	14.25	362	3.75	95
100 A	32	54	<b>QP32100</b>	#4-2/0	26.25	667	14.25	362	3.75	95
200 A	40	80	<b>QP40200</b>	#4-250	34.00	864	14.25	362	3.75	95
200 A	60	80	<b>QP60200</b> ⓘ	#4-300	41.25	1048	14.25	362	3.75	95

ⓘ Does not include a door. Order kit # QODK60-2 for door. Rated 200 A maximum with aluminum conductors, 225 A with copper conductors.

Each Panel Package includes:



Each Panel Package includes 2 filler plates



- Main Breaker
- Tub, Trim and Interior
- Selection of breakers:
  - 10 - Single Pole 15A QO Breakers
  - 3 - Double Pole 15A QO Breakers
  - 1 - Double Pole 30A QO Breaker
  - 1 - Double Pole 40A QO Breaker

# Square D Sub Panels

## QO™ Main Lugs Indoor Loadcentres

Main lugs loadcentres are typically used as an add-on loadcentre and is connected to the service entrance loadcentre when spaces for more circuits are needed or when a main disconnect is located elsewhere. It does not contain a main breaker. Square D offers a variety of sizes to meet various applications within the home.

- Expandable loadcentre capacity with the use of QO™ tandem breakers.
- CSA approved for vertical, horizontal or inverted mounting.
- Accepts aluminum or copper conductors.
- Lifetime limited Warranty.

8 Space Sub Panel



### Main Lugs Loadcentre Selection (1 Phase, 3 Wire, 120/240 Vac)

Bus Amp Rating	Number of QO Circuits		Catalogue Number	Main Wire Size AWG/kcmil AL/Cu	Product Dimensions					
	Standard	Tandem			Height		Width		Depth	
					Inches	mm	Inches	mm	Inches	mm
30 A	2	4	<b>QO2L30SC</b> ④	#12-10Al/#14-10Cu	6.75	171	3.75	95	3.00	76
70 A	2	4	<b>QO2L70S</b> ⑤	#12-3Al/#14-4Cu	9.25	235	4.75	121	3.25	83
100 A	4	8	<b>QO4L100S</b> ⑥	#8-1	12.75	324	9.00	229	3.75	95
100 A	6	12	<b>QO6L100S</b> ⑥⑦	#8-1	12.75	324	9.00	229	3.75	95
100 A	8	15	<b>QO8L100S</b> ⑥⑦	#8-1	12.75	324	9.00	229	3.75	95
100 A	12	24	<b>CQO112L100PGC</b> *	#4-1	18.00	457	14.25	362	3.75	95
100 A	16	32	<b>CQO116L100PGC</b> *	#4-1	18.00	457	14.25	362	3.75	95
125 A	24	48	<b>CQO124L125PGC</b> *	#4-2/0	21.00	533	14.25	362	3.75	95
125 A	16	32	<b>CQO132L125PGC</b> *	#4-2/0	26.25	667	14.25	362	3.75	95
200 A	40	80	<b>CQO140L200PGC</b> *	#4-250	34	864	14.25	362	3.75	95

① Substitute "S" with "F" at end of part number for Flush cover panel.

② Accepts maximum 70A branch breaker.

③ Accepts maximum 20A GFI or AFI breaker.

④ Will not accept QO-GFI or QO-EPD breakers.

\* Plug-on Neutral Ready - Accepts no pigtail CAFI breakers.

## QO™ Main Lugs Outdoor Loadcentres

- Type 3R outdoor enclosure.
- Enclosures are CSA certified for vertical mounting only.
- Lifetime limited Warranty.

2 Space Outdoor Panel



### Outdoor Main Lugs Loadcentre Selection (1 Phase, 3 Wire, 120/240 Vac)

Bus Amp Rating	Number of QO Circuits		Catalogue Number	Main Wire Size AWG/kcmil AL/Cu	Product Dimensions					
	Standard	Tandem			Height		Width		Depth	
					Inches	mm	Inches	mm	Inches	mm
70 A	2	4	<b>QO2L70RB</b> ⑧	#12-3Al/#14-4Cu	9.50	241	5.00	127	4.00	102
100 A	6	12	<b>QO6L100RB</b>	#8-1	12.75	324	9.00	229	4.25	108
100 A	8	15	<b>QO8L100RB</b>	#8-1	12.75	324	9.00	229	4.25	108
100 A	16	32	<b>CQO116L100PGRB</b>	#4-1	22.25	565	14.25	362	4.50	114

⑧ Accepts maximum 20A GFI or AFI breaker.

\* Plug-on Neutral Ready - Accepts no pigtail CAFI breakers.



# Square D Main Breaker Only Loadcentres

This service entrance panel is connected to the electrical meter and distributes electricity throughout the home. Each is equipped with a factory installed main circuit breaker, which serves as the main disconnect to turn off power to the loadcentre, as well as to protect the load center from an overload or short circuit.

## Main Breaker Loadcentre Features:

- Factory installed 60 A, 100 A or 200 A main breaker.
- Plug-on neutral ready.
- Suitable for surface or flush mounting.
- CSA approved for vertical, horizontal or inverted mounting.
- Tin plated copper bus bars
- Tandem breakers allow you to easily expand the loadcentre capacity.
- Lifetime limited Warranty.



24 Circuit Main Breaker Only Panel



Plug-on Neutral Ready

## Main Breaker Loadcentre Selection (1 Phase, 3 Wire, 120/240 Vac)

Main Amp Rating	Number of QO Circuits		Catalogue Number	Main Wire Size AWG/kcmil AL/Cu	Product Dimensions					
	Standard	Tandem			Height		Width		Depth	
					Inches	mm	Inches	mm	Inches	mm
60 A	12	24	<b>CQO112M60PC</b>	#4-1	15.00	381	14.25	362	3.75	95
60 A	16	32	<b>CQO116M60PC</b>	#4-1	18.00	457	14.25	362	3.75	95
60 A	24	48	<b>CQO124M60PC</b>	#4-2/0	21.00	533	14.25	362	3.75	95
100 A	16	32	<b>CQO116M100PC</b>	#4-1	18.00	457	14.25	362	3.75	95
100 A	24	48	<b>CQO124M100PC</b>	#4-2/0	21.00	533	14.25	362	3.75	95
100 A	32	54	<b>CQO132M100PC</b>	#4-2/0	26.25	667	14.25	362	3.75	95
100 A	40	80	<b>CQO140M100PC</b>	#4-2/0	34.00	864	14.25	362	3.75	95
125 A	32	54	<b>CQO132M125PC</b>	#4-2/0	26.25	667	14.25	362	3.75	95
150 A	40	80	<b>CQO140M150PC</b>	#4-250	34.00	864	14.25	362	3.75	95
150 A	60	80	<b>CQO160M150PC</b>	#4-250	41.25	1048	14.25	362	3.75	95
200 A	32	54	<b>CQO132M200PC</b>	#4-250	26.25	667	14.25	362	3.75	95
200 A	40	80	<b>CQO140M200PC</b>	#4-250	34.00	864	14.25	362	3.75	95
200 A	60	80	<b>CQO160M200PC</b> <sup>❶</sup>	#4-300	41.25	1048	14.25	362	3.75	95

❶ Does not include a door. Order kit # QODK60-2 for door. Rated 200A maximum with aluminum conductors, 225 A with copper conductors.

# Square D NQ 300A/400A Loadcentres

The Square D NQ service entrance loadcentres meet Canadian standards, and are marked cULus. They are 120/240V rated with a NEMA 1 enclosure for indoor use only, and are compatible with high quality Square D QO/QOB (plug on and bolt on) branch breakers.

## NQ Loadcentre Features:

- Surface mount trim approved for top or bottom feed
- Accepts aluminum or copper wire
- Standard shielded copper bus interior
- Uses wide variety of QO/QOB breakers including space saver breakers with VisiTrip indicator for easy identification of tripped breakers



## NQ Loadcentre Selection (1 Phase, 3 Wire, 120/240 Vac)

Main Amp Rating	Number of QO Circuits		Catalogue Number	Main Wire Size AWG/kcmil AL/Cu	Product Dimensions					
	Standard	Tandem			Height		Width		Depth	
					Inches	mm	Inches	mm	Inches	mm
300 A	42	84	<b>NQSE142300S</b>	1/0 - 750kcmil	62.00	1575	20.0	508	5.75	146
300 A	42	84	<b>NQSE142300F</b>	1/0 - 750kcmil	63.50	1613	21.50	546	5.75	146
300 A	84	120	<b>NQSE184300S</b>	1/0 - 750kcmil	80.00	1524	20.0	508	5.75	146
300 A	84	120	<b>NQSE184300F</b>	1/0 - 750kcmil	81.50	2070	21.50	546	5.75	146
400 A	42	84	<b>NQSE142400S</b>	1/0 - 300kcmil	62.00	1575	20.0	508	5.75	146
400 A	42	84	<b>NQSE142400F</b>	1/0 - 300kcmil	63.50	1613	21.50	546	5.75	146
400 A	84	120	<b>NQSE184400S</b>	1/0 - 300kcmil	80.00	1524	20.0	508	5.75	146
400 A	84	120	<b>NQSE184400F</b>	1/0 - 300kcmil	81.50	2070	21.50	546	5.75	146

S -Surface Trim  
F - Flush Trim

# Square D Generator Panels

The Square D generator panels allows you to permanently connect a standby power source to specific circuits, such as lighting, heating, refrigerator, freezer, and sump pump. You can easily switch the power supply to branch circuits by turning off the utility main breaker and turning on the main breaker connected to the generator.

For added safety, an easy to use rotating interlock bracket allows only one main breaker to be on the "ON" position at the same time. Ideally suited for residential, rural, commercial applications requiring a quick and easy switch over from utility power to standby generator power.

## Generator Panel Features:

- Large circuit breaker capacity. Accepts up to 18 standard or 36 QO™ tandem circuits.
- Plug-on neutral ready.
- Includes two factory installed 30 A or 60 A 3 pole main breakers.
- Ease of use from our patented rotating interlock bracket design.
- Manually switch from utility power to stand-by generator power in seconds.
- Suitable for generators having either bonded or unbonded neutral conductors.
- 30 A or 60 A 3-pole utility/generator circuit breakers switch both line & neutral conductors in accordance with the Canadian Electrical Code.
- Type 1 Indoor Enclosure with surface/flush mounted trim.



Plug-on Neutral Ready



60 A Generator Panel

## Generator Panel Selection (1 Phase, 3 Wire, 120/240 Vac)

Main Amp Rating	Number of QO Circuits		Catalogue Number	Main Wire Size AWG/kcmil AL/Cu	Product Dimensions					
	Standard	Tandem			Height		Width		Depth	
					Inches	mm	Inches	mm	Inches	mm
30 A	18	36	<b>QOGP3P3036P</b>	#14-8	17.8	381	14.25	362	3.75	95
60 A	18	36	<b>QOGP3P6036P</b>	#8-2	17.8	381	14.25	362	3.75	95

## Patented Easy to use Rotating Interlock Bracket



# Square D All-in-one Generator Panels

The Square D All-in-one Generator Panels offer the best solution for new installations with a easy to use back up power. The entire unit is in a single enclosure with a pre-wired service entrance loadcentre and generator.

This All-in-one Generator Panel offers plenty of space for any application in the home with a total of 80 circuits using tandem breakers and a total of 36 circuits using tandem breakers for backup purposes.

## Generator Panel Features:

- Large circuit breaker capacity.
- Includes two factory installed 60 A 3 pole main breakers.
- Plug-on neutral ready.
- Accepts no pigtail Combination Arc Fault breakers, eliminating the need to attach a separate neutral wire to the neutral bar.
- Ease of use from our patented rotating interlock bracket design.
- Manually switch from utility power to stand-by generator power in seconds.
- Suitable for generators having either bonded or unbonded neutral conductors.
- 60 A 3-pole utility/generator circuit breakers switch both line & neutral conductors in accordance with the Canadian Electrical Code.
- Includes cover with door.



Plug-on Neutral Ready



200 A All-in-one Generator Panel

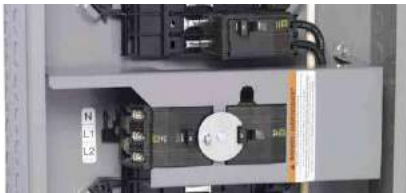

## Combination Generator Panel Selection (1 Phase, 3 Wire, 120/240 Vac)

Main Amp Rating	Number of QO Circuits		Number of QO Circuits (Generator)		Catalogue Number	Product Dimensions					
	Standard	Tandem	Standard	Tandem		Height		Width		Depth	
						Inches	mm	Inches	mm	Inches	mm
100 A	40	80	18	36	QOGP3P604436100P	38.00	965	14.25	362	3.75	95
200 A	40	80	18	36	QOGP3P604436200P	38.00	965	14.25	362	3.75	95

All-in-one Generator Panels have a main wire size of #4-250



## FAST FACTS

Not using a generator panel with a generator for home back up power can be dangerous. Without a generator panel you can accidentally back feed power back to the grid.

# Square D Loadcentres Accessories

## Accessory Selection

Accessory	Description	Catalogue Number	Catalogue Number
Filler Plates	Fills branch breaker openings in cover	<b>QOFPCP</b>	
Lock Kits	Converts door latch from spring catch to lock type	<b>PK6FL</b>	
Interchangeable Hubs	Conduit Size	Type B Hub	Type MH Hub
	Closing Plate	<b>BCAP</b>	<b>MHC</b>
	3/4"	<b>B-075</b>	<b>MH75</b>
	1"	<b>B-100</b>	<b>MH100</b>
	1 1/4"	<b>B-125</b>	
	1 1/2"	<b>B-150</b>	<b>MH150</b>
Neutral Extension Kit	Loadcentre	Description	Catalogue Number
	24 Circuit Panels 32 Circuit Panels 42 Circuit Panels	14 Neutral Ports x 2	<b>QONK1</b>
	40 Circuit Panels 60 Circuit Panels	22 Neutral Ports x 2	<b>QONK2</b>



QOFPCP



PK6FL



BCAP



B-100



B-150



QONK2

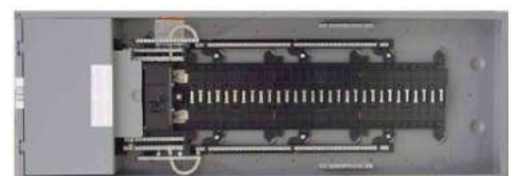

Neutral Extension Kit installed in a Square D panel

QO Neutral Extension kits:  
Increase installation flexibility.  
Multiple length available.  
Kit includes a left and right side neutral bar.  
Left side or right side installation option.



# Square D Surge Protection

Whole House Surge Protection protects all electronic devices from damage.

From televisions and home theatre systems to refrigerators and ranges, today's electronics and appliances are smarter – and more sensitive – than ever. They contain computer chips that can be damaged by even a minor electrical surge.

Surges not only overload and destroy sensitive electronics, but also shorten equipment life over time.

Point-of-use surge strips provide only partial protection. They provide limited protection for the equipment plugged into them, and no protection at all for appliances and systems that aren't connected to them.

### The Electrical System:

Surges can enter your home's electrical system or can be generated within the home. External surges are a result of lightning or utility disturbances and switching. Without proper protection, these surges produce overvoltage conditions that can overwhelm point-of-use protection like surge strips. Electrical surges can damage connected equipment and slowly destroy the insulation on the wiring in your home.

### The Telephone System:

Computer modems are among the most vulnerable electrical appliances in the home because they connect directly into telephone lines which carry surges generated by lightning activity. These surges can also damage answering machines and telephones.

### Coaxial Cable or Satellite TV System:

The coaxial cable TV system is similar to the phone system. Local lightning activity can cause surges into the coaxial cable, causing damage to connected equipment. TV receivers and satellite TV systems are also subject to damage.

# 95%

The percentage of customers who stated they have purchased surge protection within 1 year after surge damage.

## FAST FACTS

Each year it is estimated that surges cause \$26 billion in lost time, repairs and equipment.

Source: Insurance Institute for Business and Home Safety.

# SURGEBREAKER PLUS®

## Whole House Surge Protection

The cost of whole house, multi-path surge protection is minimal when compared to the replacement cost of connected equipment. Often just one piece of damaged equipment costs more to replace than your entire investment in whole house protection.

The Square D Surgebreaker Plus® Whole House Surge Protector provides Multi-Path Surge Protection that meets UL 1449 3rd Edition Standards and can be easily installed in both new and existing homes. Its solid state design protects 120/240V circuits, as well as up to four telephone lines, and coaxial television lines for cable.

### SURGEBREAKER PLUS® Features:

- Surge protects the whole house from lightning strikes and local power utilities. Provides power surge protection to all electronic equipment and household appliances in the home.
- Modular design with field replaceable 120/240 Vac line, cable, telephone and Ethernet protection components.
- Compatible with any brand of electrical panel. Connects to a dedicated 2 pole 20 A circuit breaker in the panel - sold separately.
- Compact and flexible design requires minimal space and allows product to be installed anywhere on the side or bottom of panel.
- Dual LED Indicators for protection status.
- Surge Current Rating per Phase 80,000 A.
- Short Circuit Current Rating 25,000 A.
- Metal oxide varistor (MOV) design, with less than a nanosecond response time.
- Modes of surge suppression: Line to Neutral, Line to Ground, Line to Line, Neutral to Ground.
- Warranty: up to 5 years and \$100,000 in protection.



SDSB80111CCP

### Whole House Surge Selection (1 Phase, 3 Wire, 120/240 Vac)

Catalogue Number	Cable Size Type Cu	Neutral & Ground Terminals Cu	Product Dimensions					
			Height		Width		Depth	
			Inches	mm	Inches	mm	Inches	mm
<b>SDSB80111CCP</b>	#12AWG	#12AWG	10.87	276	4.32	110	2.92	74

### Typical AC Surge Protector Wiring Connection Diagram

Install the Whole House Surge Protector directly to a new 20A 2 Pole circuit breaker in your panel.

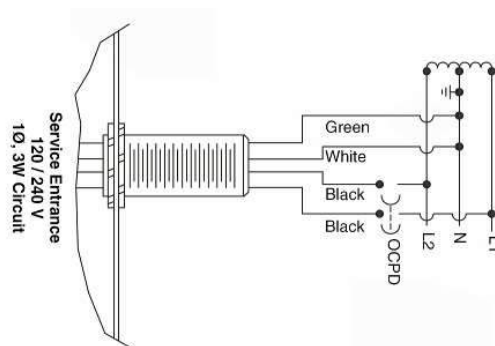

# Home Electronics Protective Devices

## Electrical Whole House Surge Protection

Square D™ brand Home Electronics Protective Devices (HEPDs) are compact and affordable surge protectors designed for residential loadcentres. HEPDs provide electrical whole house surge protection for sensitive electronics. HEPDs reduce surges that might otherwise overwhelm plug strips and damage connected household equipment. HEPDs also provide surge protection for important items such as washers, dryers, refrigerators, stoves, and lighting that plug strips don't protect.

### HEPD80C Features:

- Compatible with any brand of electrical panel, model or design.
- Surge Current Rating per Phase 80,000 A.
- Short circuit current rating: 25,000 A.
- Each Metal Oxide Varistor (MOV) is individually fused.
- NEMA Type 4X enclosure rating suitable for installing indoors, outdoors, or in other harsh environments.
- US and Canadian UL Listed as Type 1 SPD to UL 1449 3rd Edition.
- LED indicates operational status.
- Small size will fit any installed panel. Convenient side-nipple mounting.
- Convenient side-nipple mounting.
- Warranty: up to 5 years and \$75,000 in protection.



HEPD80C

### HEPD50C Features:

- Compatible with any brand of electrical panel, model or design.
- Surge Current Rating per Phase 50,000 A.
- Short circuit current rating: 25,000 A.
- Each Metal Oxide Varistor (MOV) is individually fused, with both thermal and overcurrent fusing
- NEMA Type 4X enclosure rating suitable for installing indoors, outdoors, or in other harsh environments.
- US and Canadian UL Listed as Type 1 SPD to UL 1449 4th Edition.
- LED indicates operational status.
- Small size will fit any installed panel - 100A or 200A panels.
- Convenient side-nipple mounting.
- Warranty: up to 3 years and \$50,000 in protection.



HEPD50C

### HEPD Selection (1 Phase, 3 Wire, 120/240 Vac, 60Hz)

Catalogue Number	Modes of Protection	MCOV	VPR				Product Dimensions					
							Height		Width		Depth	
			L-N	L-G	L-L	N-G	Inches	mm	Inches	mm	Inches	mm
HEPD80C	6	150V	600V	700V	1000V	1000V	3.72	94	3.23	82	2.1	53
HEPD50C	6	150V	600V	700V	1000V	900V	3.75	95	3.60	91	2.67	68

Flush mounting bracket catalogue number (For flush mounted panels): **HEPD58MKF**







# Square D Safety Switches

Safety switches isolate power in daily activities and provide an effective way to shut power off in an emergency. General duty safety switches are designed for residential and commercial applications where durability and economy are prime considerations. Typical loads are lighting, air conditioning and appliances.

The switches are also suitable as service equipment when equipped with a factory-installed neutral assembly or a field-installed equipment grounding kit.

## General Features:

- Fusible or non fusible.
- 30–200 A rated for application loads up to 240 V .
- Up to 100 kA SCCR, utilizing appropriately rated Class R Class J or Class T fuses or fuse kits.
- Available with glass or cartridge fuse protection.
- Horsepower rated for motor applications.
- Available in Type 1 (indoor) and 3R (outdoor) enclosures.
- Tangential combination knockouts 30–200 A.
- Spring reinforced plated copper fuse clips.
- Insulated, bonded solid neutral assemblies (standard in fusible switches).
- Visible blades.
- Quick-make, quick-break operating mechanism.
- Cover padlock and handle lock “OFF”.



## FAST FACTS

The company, **Detroit Fuse and Manufacturing** was credited with inventing the Safety Switch. Later renamed **Square D**, the classic Square D logo was stamped on all switches and products. The capital letter “D” in the square stands for Detroit.



by **Schneider Electric**

# General Duty Safety Switches

Square D general duty safety switches meet the needs of residential and commercial applications with many features designed for economy, safety, and superior performance. Typical applications include residential, farm and small business service entrances and light-duty branch circuit disconnects.

Home applications include disconnecting power to well pumps, workshops, hobby room, furnaces and garages.

## General Duty Switch Features:

- 240 Vac maximum.
- Type 1 indoor enclosure.
- Service entrance rated (60 A and above switches).
- Lugs suitable for Al or Cu conductors.
- Spring reinforced plated copper fuse clips.
- Multiple padlock provisions in "OFF" position.



30 A Plug Switch

## Safety Switch Selection

Amp Rating	Catalogue Number	Fuse Type	Horsepower Rating - 1Ø		Product Dimensions					
			Standard	Max.	Height		Width		Depth	
					Inches	mm	Inches	mm	Inches	mm
30 A	<b>L111N</b>	Plug	0.5	2	7.63	194	5.00	127	4.00	102
30 A	<b>CD211NCP</b>	Plug	1.5	3	9.25	235	6.75	171	3.63	92
30 A	<b>CD221NCP</b>	Cartridge	1.5	3	9.25	235	6.75	171	2.63	92
60 A	<b>CD222N</b>	Cartridge	3	10	14.63	372	6.50	165	4.88	124
100 A	<b>CD223N</b>	Cartridge	7.5	15	17.50	445	8.50	216	6.50	165
200 A	<b>CD224N</b>	Cartridge	15	-	29.00	737	17.25	438	7.00	178

## Non Fusible Double Throw Safety Switches

Designed for the manual transfer of loads from one supply to another.

## Double Throw Safety Switch Features:

- 240 Vac/250 Vdc, non-fusible, 2 pole.
- Type 1 indoor enclosure.
- May be padlocked ON or OFF.
- Lock-off accepts up to three padlocks.
- Modular design - switch handle, lock-plate, switch.

## Double Throw Safety Switch Selection

Amp Rating	Catalogue Number	Horsepower Rating - 1Ø		Product Dimensions					
		Standard	Max.	Height		Width		Depth	
				Inches	mm	Inches	mm	Inches	mm
60 A	<b>DTU222</b>	10	-	30.00	762	10.25	260	6.93	176
100 A	<b>DTU223</b>	15	-	30.00	762	10.25	260	6.93	176



60A Double Throw Switch

# Air Conditioner Disconnect

Air Conditioner disconnects allows repair personnel to safely perform maintenance on residential A/C units. The preferred moulded case switch of electrical and mechanical contractors became the industry standard over the years because of innovative Square D features. For use as a disconnecting means on residential and commercial air conditioning installations, as well as other single-phase applications, such as swimming pools and pump houses.

## A/C Disconnect Features:

- Non-fusible moulded case switch.
- NEMA Type 3R metallic enclosure.
- 240 Vac single-phase, two-wire.
- Tin plated copper contacts.
- No pullout handle to misplace.
- Easy to use moulded case switch has simple on/off switch.
- Has no exposed contacts. (unlike pullout switches)

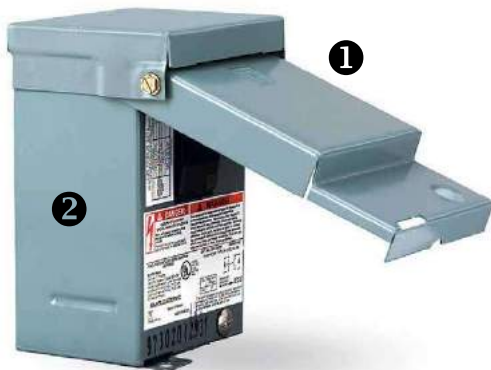

- 1 Removable cover housing (front, top and side walls) provides open area for mounting and convenient installation.
- 2 Compact, rugged long life galvanized steel enclosure with powder coat paint for long lasting corrosion protection.

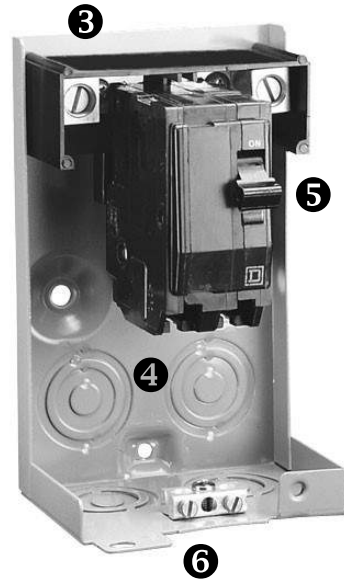

- 3 Easy access to wiring terminals for conductor installation.
- 4 Four convenient one inch combination knockout provisions on back and bottom enclosure walls provide wiring flexibility.
- 5 60 A/240 Vac max. not-fusible moulded case switch included.
- 6 Cover padlock provision.

## A/C Disconnect Selection

Amp Rating	Catalogue Number	HP Rating	Cable Size	Neutral & Ground Terminals Cu	Product Dimensions					
					Height		Width		Depth	
					Inches	mm	Inches	mm	Inches	mm
60 A	CQO200TR	10	#14-4	(2)#14-4	6.50	165	4.62	117	3.87	98

Optional part number PKHB (Available only in multiples of 10) mounting bracket, when used, simplifies installation for stucco, stone, brick and lapped-sided applications.



The bracket mounts directly onto the stud.

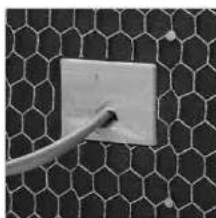

Bracket after tar paper and stucco wire have been added to the studs.



Stucco covering the bracket is chipped away.



The CQO200TR is mounted to the bracket with screws



# Square D Pressure Switches

## Water and Air Control Switches

Designed to monitor and control electrically driven water pumps, Square D Pumptrol® Pressure Switches are ideal for jet, submersible and reciprocating systems. These durable pressure switches monitor systems to start and stop a pump at pre-set pressures.

### Applications:

Square D Pumptrol Water pressure switches are ideal for rural customers who usually rely on wells to supply their water. Pumps are used to bring up the water from the well and to pressurize the water pipes in the home. Water is pumped into a storage tank to compress an air bladder that exerts pressure on the water in the home. When the desired pressure is reached, the pump must be stopped. This is where the pressure switch opens a set of electrical contacts to stop the pump. When water is used, the pressure in the storage tank falls. When the lowest desired pressure is reached, the switches close to start the pump and recharge the system pressure. The most common water pump pressure settings are 20 to 40 pounds per square inch (p.s.i.), 30 to 50 p.s.i. or 40 to 60 p.s.i. The low number is the cut-in pressure, and the high number is the cut-out pressure.

Square D Pumptrol Air Compressor switches are ideal for controlling small electrically driven compressors.



# Square D Water Pump Pressure Switches

The Type FSG - PUMPTROL® Water Pump Pressure Switches are used to control electrically driven water pumps, suitable for all types of pumps: jets, submersible, reciprocating, etc.

## General Features:

- NEMA Type 1 indoor enclosure.
- 2 pole, rated 1-1/2HP @115 Vac, 2HP@230 Vac.
- Adjustable cut-in/out.
- Maximum pressure 220 PSIG.
- Diaphragm actuated.
- UL, CSA Listed.
- Electrical durability: 100,000 cycles; Mechanical durability 300,000 cycles.
- Corrosion-resistant plating: environmentally friendly, RoHS compliant.
- Long, dependable electrical life: heavy duty thick contacts (+0.005–0.010 in. thicker than competitors).
- Secure grounding, less wiring time: hold tight terminations secure ground wire strands.
- 3rd party low lead certified to NSF/ANSI 61 and Annex G.



FSG2J20BP

## Water Pump Switch Selection

Catalogue Number	Approximate Differential Adjustable (PSIG)	Cut-Out Range (PSIG)	Cut-In Range (PSIG)	Poles	Pressure Connection	Pressure Setting	Additional Features
FSG2J20BP	15-30	20-65	5-45	2	1/4" NPSF	20-40 PSI	
FSG2J20CP	15-30	20-65	5-45	2	1/4" NPSF	20-40 PSI	
FSG2J20M4BP	15-30	20-65	5-45	2	1/4" NPSF	20-40 PSI	Low Pressure Cut-off
FSG2J21BP	15-30	20-65	5-45	2	1/4" NPSF	30-50 PSI	
FSG2J21CP	15-30	20-65	5-45	2	1/4" NPSF	30-50 PSI	
FSG2J21M1BP	15-30	20-65	5-45	2	1/4" NPSF	30-50 PSI	Manual cut-out lever
FSG2J21M4BP	15-30	20-65	5-45	2	1/4" NPSF	30-50 PSI	Low Pressure Cut-off
FSG2J24BP	15-30	20-65	5-45	2	1/4" NPSF	40-60 PSI	
FSG3J20BP	15-30	20-65	5-45	2	3/8" NPSF	20-40 PSI	

## Dimensions

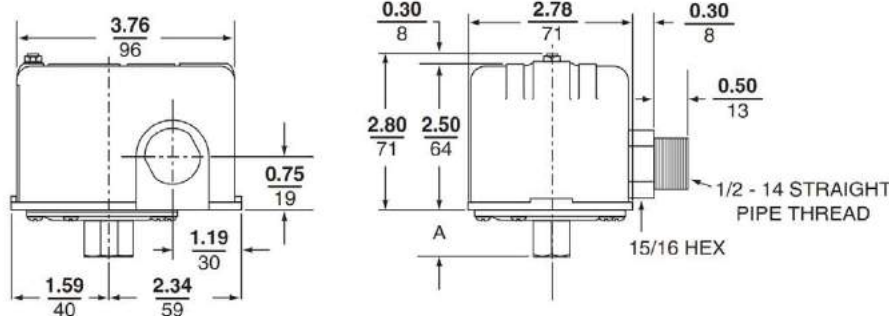

## Adjustable Switching Point

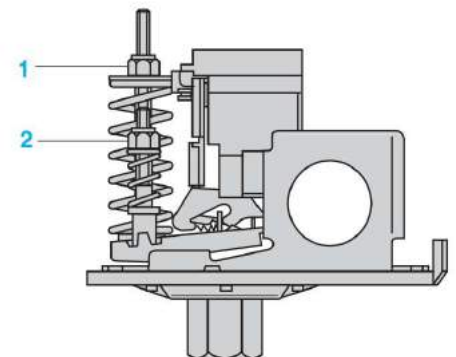

- 1 Switching point on falling pressure set by adjusting screw-nut.
- 2 Switching point on rising pressure set by adjusting screw-nut.

# Square D Air Compressor Pressure Switches

Square D Pumptrol Air Compressor switches are ideal for controlling small electrically driven compressors.

## General Features:

- NEMA Type 1 indoor enclosure.
- 2-pole switch rated 1-1/2HP@115 Vac, 2HP@230 Vac.
- Diaphragm actuated.
- Adjustable cut-out pressure.
- Fixed differential pressure, maximum pressure 220 PSIG.



FHG2J27BP

## Air Compressor Switch Selection

Catalogue Number	Approximate Differential Non-Adjustable (PSIG)	Adjustable Cut-Out Range Increasing Pressure (PSIG)	Poles	Pressure Connection	Pressure Setting	Two Way Pressure Release Value
FHG12J52XBP	30	70-150	2	1/4" NPSF	Off @ 125PSI	Yes
FHG12J55XBP	30	70-150	2	1/4" NPSF	Off @ 150PSI	Yes
FHG2J27BP	20	40-100	2	1/4" NPSF	Off @ 100PSI	No

## Dimensions

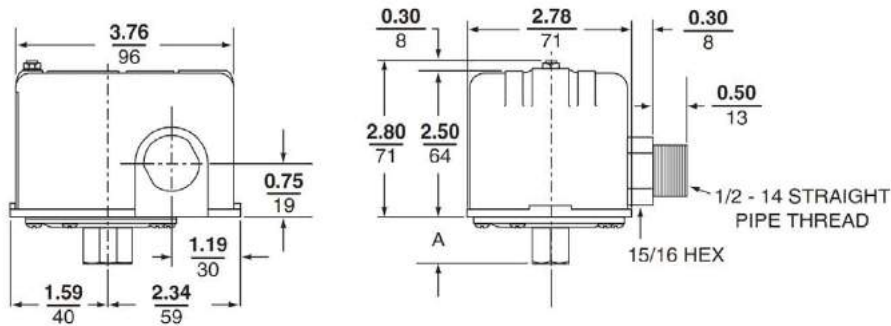

## Adjustable Switching Point

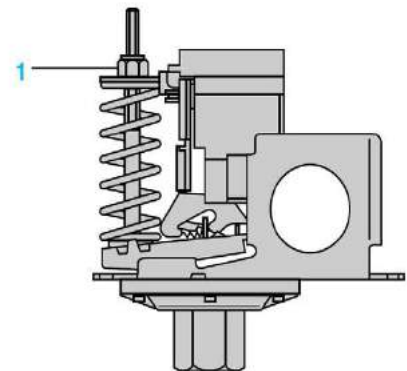

1 Switching point on rising pressure set by adjusting screw-nut.



# Stab-lok™ Circuit Breakers

## Stab-lok™ ...easier to work with and faster to install

Stab-lok™ breakers are fully interchangeable with all past breakers and deliver the same proven quality. The unique Stab-lok™ breaker design of only a 1/2" wide per pole, allows for the reduction of the size and weight of the loadcentre. These breakers are CSA approved to work only in Federal Pioneer branded residential panels.

Stab-lok™ breakers are easily identifiable by their unique architectural white colour and colour handles.



### Stab-lok™ Breaker Features:

- Provides overload and short circuit protection.
- Colour coded handles: identification is quick and easy with separate colours representing different ampere ratings.
- Provides Slot/Robertson screws.
- Thermal magnetic trip protection.
- Calibrated at 40 degrees Celsius.
- Arc resistant case.

### FAST FACTS

2 Pole Stab-lok breakers must be installed 'across' the black dividers on the busbar for 240V output voltage.



# Circuit Breaker Product Selection Guide

## Plug-On Circuit Breakers Selection - 10,000 AIR

Amp Rating	Type	One Pole 120 Vac	Lug Range	Two Pole 240 Vac	Lug Range
15 A	NC	NC015CP❶	#14-#6	NC0215CP	#14-#6
20 A		NC020CP❶		NC0220CP	
25 A		NC025CP		NC0225CP	
30 A		NC030CP		NC0230CP	
40 A		NC040CP		NC0240CP	
50 A				NC0250CP	#14-#4
60 A				NA260CP	
70 A				NA270CP	
100 A				NA2P100CP	#4-2/0
125 A				NA2P125CP	#4-2/0
150 A				NA2P150CP❷	#4-2/0

❶ Single Pole 15 A and 20 A breakers are Switching Duty Rated (SWD). Suitable for switching 120 Vac fluorescent lighting loads.

❷ NA2P150 rated 150 A when used with copper conductor only.

### Notes:

- 1 Pole NA breakers take 2 NC breaker spaces.
- 2 Pole NA breakers take 4 NC breaker spaces.
- Use solid conductor only when #14 wire is used.

### Colour coded breaker handles:

NC015CP/NC0215CP - Black/Blue  
 NC020CP/NC0220CP - Red  
 NC030CP/NC0230CP - Green  
 NC040CP/NC0240CP - Grey  
 Greater than 50A breakers - Black



Stab-lok One Pole Breaker  
1 Space Required



Stab-lok Two Pole (NA) Breaker  
4 Spaces Required

## Stab-lok™ Arc Fault Breakers

### Stab-lok™ Arc Fault Circuit Breaker Features:

- Detects unintended arc faults, overloads and short circuits.
- **For replacement only, not suitable as for combination arc fault applications**

### Plug-On Arc Fault Circuit Breakers Selection

Amp Rating	One Pole 120 Vac
	10,000 AIR
15 A	NA15AFICP
20 A	NA20AFICP



15 A Arc Fault Breaker  
2 Spaces Required



# Stab-lok™ Main Breakers

Use QO Main Circuit Breakers found on page 26



100A Main Breaker

# Stab-lok™ Accessories

Accessory Selection

Accessory	Description	Catalogue Number
Filler Plates	Fills branch breaker openings in cover	PF1CP
Replacement Amalgamated Electric Fuse Holders	Twin Single Pole Plug-In Head 15 to 30A	7301CP
	Two Pole Plug-In Fuse Head 15 to 30A	7302CP
Handle Tie	Suitable for square handled NC breakers.	HTNCCP
Handle Lock Off Handle Tie	Non-Padlocking Suitable for ribbed handled NC 1 + 2 pole breakers.	NC-LOK



PF1CP



7301CP



7302CP



HTNCCP



NC-LOK



# Wiser Energy System

## Residential Energy Monitoring

Wiser Energy™ System from Schneider Electric, is an integral part of any smart home. It helps you keep tabs on your home by notifying you when devices are on or off and monitors energy usage in real time, for a safer and more efficient home.

Adding Wiser Energy to your electrical panel will allow you to make your home safer, greener and more efficient

- 📱 Easy to use intuitive mobile app from Sense
- 🏠 Always learning and self identifies devices in your home
- 🔔 Set custom alerts for devices in your home such as when the garage door opens, the sump pump turns on, or when the dryer's done
- 🌿 Displays energy consumption by appliance, i.e. refrigerator or pool pump, air conditioner or electric hot water heater
- 📊 24/7 real-time view of energy consumption and production (Solar)
- 💰 Set budgets to manage your energy expenditures before you get a bill
- 🔧 Simple installation into new or existing electrical panel, by certified electrician



Works with a growing list of smart devices like Google Home™, Philips Hue, Wemo® Insight™ and Kasa™ smart plugs.

# Wiser Energy Components



## Specifications

Catalog Number		WISEREM	WISEREMPV	WISERCTPV
Technical Description		Wiser Energy Disaggregation Monitoring	Wiser Energy Solar Disaggregation Monitoring	Wiser Energy Solar CT Kit
Compatibility		120VAC (90V-130V), 60Hz 120V split-phase service		
		Suitable for indoor or outdoor rated panels		
Current Transformers	CT Specs	CAT III 300V 200A max		
	CT Type	Split-core		
	Cable Length	46"		
	Inside Diameter	1"		
Wireless	Wifi	802.11b/g/n Wi-Fi		N/A
	Bluetooth	Y		N/A
	Bandwidth	~300MB/day		N/A
Signal Processing	Sampling Rate	1MHz		N/A
	Data Points/Second	4M		N/A
	Processor	1GHz ARM		N/A
Power Consumption		< 5W, 0.1A		N/A
NEMA Type (Hub)		IPX0	IPX0	N/A
Environmental Ratings	Temperature	32-140°F (0-60°C)		
	Elevation	< 6561 ft. (2,000m)		
Certification		cETLus, FCC Conforms to UL STD 61010-1; UL STD 61010-2-032; Certified to CSA STD C22.2 No. 61010-1; Conforms to CAN ICES-3(B)/NMB-3(B)	cETLus, FCC Conforms to UL STD 61010-1; UL STD 61010-2-032; Certified to CSA STD C22.2 No. 61010-1; Conforms to CAN ICES-3(B)/NMB-3(B)	cETLus, FCC Conforms to UL STD 61010-1; UL STD 61010-2-032; Certified to CSA STD C22.2 No. 61010-1; Conforms to CAN ICES-3(B)/NMB-3(B)
RoHS Compliant?		Y	Y	Y
Mechanical Specs	W x H x D (mm)	137 x 66 x 32	137 x 66 x 32	85.73 x 50.8 x 19.05
	W x H x D (in)	5.4" x 2.6" x 1.3"	5.4" x 2.6" x 1.3"	3.375" x 2" x .75"

# Mobiya LED Lantern

## Solar LED Lantern Lighting System

The Mobiya (TS 170L) solar lantern is a portable LED lighting system that provides a safe, shock resistant, green (no batteries needed) and reliable source of a lighting and energy. Lightweight, durable and water resistant – the Mobiya LED lantern is ideal for camping, boating, hiking, beach parties, backyard or emergency lighting. With its innovative multiple charging options, the Mobiya lantern conveniently lights up your surroundings (indoors or outdoors) by the included solar panel or USB universal charging cable.

### Features:

- Multiple options for brightness: 170 Lumens for 6 hours, 85 lumens for 12 hours or 20 lumens for 48 hours
- Level Indicator: Push button 1 time: low light, 2 times: medium light, 3 times: high light and 4 times: off
- Multipurpose: use as a lantern, emergency power outages, or charge your phone, water resistant up to .05m depth for 1 hour
- Colour of LEDs: Warm White 5000k
- Battery Type: 3.2 V, 3,000 mAh Lithium Ferro Phosphate power
- Package contents: portable Lamp, solar panel with 5m cable, universal mobile charging cable - with USB Micro-B, USB Mini-B cables similar to that of a ground-fault circuit interrupter.



Catalogue Number	Product Dimensions					
	Height		Width		Depth	
	Inches	mm	Inches	mm	Inches	mm
AEPLB01SU12W	6.14	156	5.59	142	5.59	142



# Application Guides

## Electrical Protection for the Whole House Inside and outside the house

For the Garage or Shed



### Safety Switches

Safety switches can be used in the workshop or shed for the quick disconnect of power for tools or shop equipment. Square D general duty safety switches offer both plug in and cartridge overload protection.



### Sub Panel

Square D and HomeLine Sub Panels can expand the number of circuits in the home. Useful if you need additional circuits for a new bedroom, game room, garage, shed or workshop.

# Electrical Protection for the Whole House

## For Central Air Conditioners



### Air Conditioner Disconnect

Air Conditioner disconnects offer a quick disconnect for central home Air Conditioner units when maintenance work is required on the unit. Square D A/C disconnects offer a unique moulded case breaker switch.

## For the Pool or Hot tub



### Spa Pack

The Square D or HomeLine Spa Packs are used to protect people from electrical shocks around the pool, spa, fountain or hot tub. The Square D Spa Pack offers a polymer, compact outdoor/indoor enclosure with door hinge while HomeLine offers a metallic outdoor/indoor enclosure.

## For Back up power in the house



### Generator Panels

The generator panel is used with your portable generator for backup power in your home in case of power outages. Unique, easy to use rotary dial easily transfers power to backup in seconds.

## For surge protecting all electrical devices and kitchen appliances



### Whole House Surge Protectors

Whole House Surge Protection is used to protect all your electronic equipment and appliances in your home from external surges like nearby lightning strikes or power fluctuations.

# Circuit Breaker Application Guide

Circuit Breaker Application	Circuit Breaker Needed		Copper Wire Size		
	Poles	Amps			
<b>AIR CONDITIONER:</b>					
120V-up to 11,000BTU ③	1	15	14-2②		
<b>ATTIC FAN: 120v-up to 1/2/ HP</b>	<b>1</b>	<b>15</b>	<b>14-2v</b>		
<b>BRANCH CIRCUIT:</b>					
Branch Circuit Outlets	120V-15 AMP	1	15	14-2②	
Bathroom Outlet ①	120V-15 AMP	1	15	14-2②	
Garage Outlet ①	120V-15 AMP	1	15	14-2②	
Kitchen Split Outlet	120V-15 AMP	OR	2	15	14-3②
	120V-20 AMP		1	20	12-2②
New for 2015 Combination Arc Fault Circuit Interrupter All Branch circuit outlets 15A/20A - 125V (exception - kitchen/bathroom/sump pump)		1	15/20	14-2/12-2②	
Outdoor Outlet ①	120V-15 AMP	1	15	14-2②	
<b>Clothes Dryer: 240V</b>		<b>2</b>	<b>30</b>	<b>10-3②</b>	
<b>DISHWASHER: 120V</b>		<b>1</b>	<b>15</b>	<b>14-2②</b>	
<b>DOORBELL TRANSFORMER: 120V</b>		<b>1</b>	<b>15</b>	<b>14-2②</b>	
<b>ELECTRIC HEATER:</b>					
120V up to 1,500 watts		1	15	14-2②	
240V up to 3.75 KW		2	20	12-2②	
<b>ELECTRIC RANGE:</b>					
240V UP TO 12.0 KW		2	40	8-3②	
<b>FOOD WASTE DISPOSAL:</b>					
120V up to 1/2 HP ①		1	15	14-2②	
<b>HOT WATER HEATER:</b>					
240V up to 4.5 KW		2	30	10-2②	
<b>MOTORS: (Single Phase):</b>					
120V up to 1/2 HP		1	15	14-2②	
<b>OUTDOOR LIGHTING: 120V ①</b>		<b>1</b>	<b>15</b>	<b>14-2②</b>	
<b>RANGE HOOD: 120V</b>		<b>1</b>	<b>15</b>	<b>14-2②</b>	
<b>SUMP PUMP: 120V ①</b>		<b>1</b>	<b>15</b>	<b>14-2②</b>	
<b>WELL PUMP: See installation instructions and markings on the pump for proper overcurrent protection size.</b>					

- ① A Ground Fault Interrupting Circuit Breaker may be required. Please refer to your local electrical code.
- ② Equipment grounding conductors must also be included in the wiring of these circuits (e.g. 14-2 ground)
- ③ Refer to your particular units name plate for minimum circuit size.

LOCAL CODES AND SPECIFIC APPLICATIONS MAY REQUIRE DIFFERENT CONDUCTORS AND CIRCUIT BREAKERS THAN SHOWN ON THIS CHART. CONSULT A QUALIFIED ELECTRICIAN OR YOUR LOCAL ELECTRICAL INSPECTOR WHEN QUESTIONS ARISE.

# Circuit Breaker Application Guide

## Circuit Breakers:

A circuit breaker is designed to protect the wiring in a home. It automatically interrupts a circuit (shutting off the flow of electricity) whenever a circuit is overloaded or a short circuit occurs.

## Ampere Rating:

The specific continuous current on which the breaker is designed to operate.

## Maximum Voltage Rating:

Either 120 Vac for single-pole (one space) breakers or 240 Vac for double-pole (two space) breakers.

## Interrupting Rating:

The maximum fault current a breaker is designed to interrupt.

---

## Single-Pole Circuit Breaker

Available in various ampere ratings, these circuit breakers occupy one space in the load center and are used for single 120 Vac circuits. A typical residential service contains electrical branch circuits supplying wall receptacles, lighting fixtures and appliances such as dishwashers and disposals.



## Double-Pole Circuit Breaker

Also available in various ampere ratings. Appliances which require larger amounts of power (clothes dryers, ranges, furnaces, air conditioners, etc.) will use separate 30A, 40A, or 50A 240 Vac branch circuits.



## Tandem Circuit Breaker

These low amperage breakers provide two isolated single-pole circuits utilizing only one single-pole space in the load center. Only designated Square D or HomeLine load centers will accept tandem breakers.



## Quad Circuit Breaker (HomeLine only)

This circuit breaker provides three isolated circuits (two single-pole and one double-pole) utilizing two spaces in the load center. Only designated HomeLine load centers will accept quad breakers.



## Main Circuit Breaker (for replacement or conversion)

Available in various amperage ratings, this is the main circuit breaker for the load center. It may be ordered to replace the existing main breaker in a main breaker load center or to convert selected main lugs load centers into main breaker load centers.





# Square D Service Entrance Panel - Connected

Square D Service Entrance Panel

Spa Pack

Range: 20A-50A  
1 Phase 3 Wire,  
120/240V



Sub Panel

Range: 30A-125A  
1 Phase 3 Wire,  
120/240V



Surge Protection

Connect to 20A  
Double Pole Breaker



Air Conditioner Disconnect

60A  
1 Phase 2 Wire



Generator Panel

Range: 30A/60A



# HomeLine Service Entrance Panel - Connected

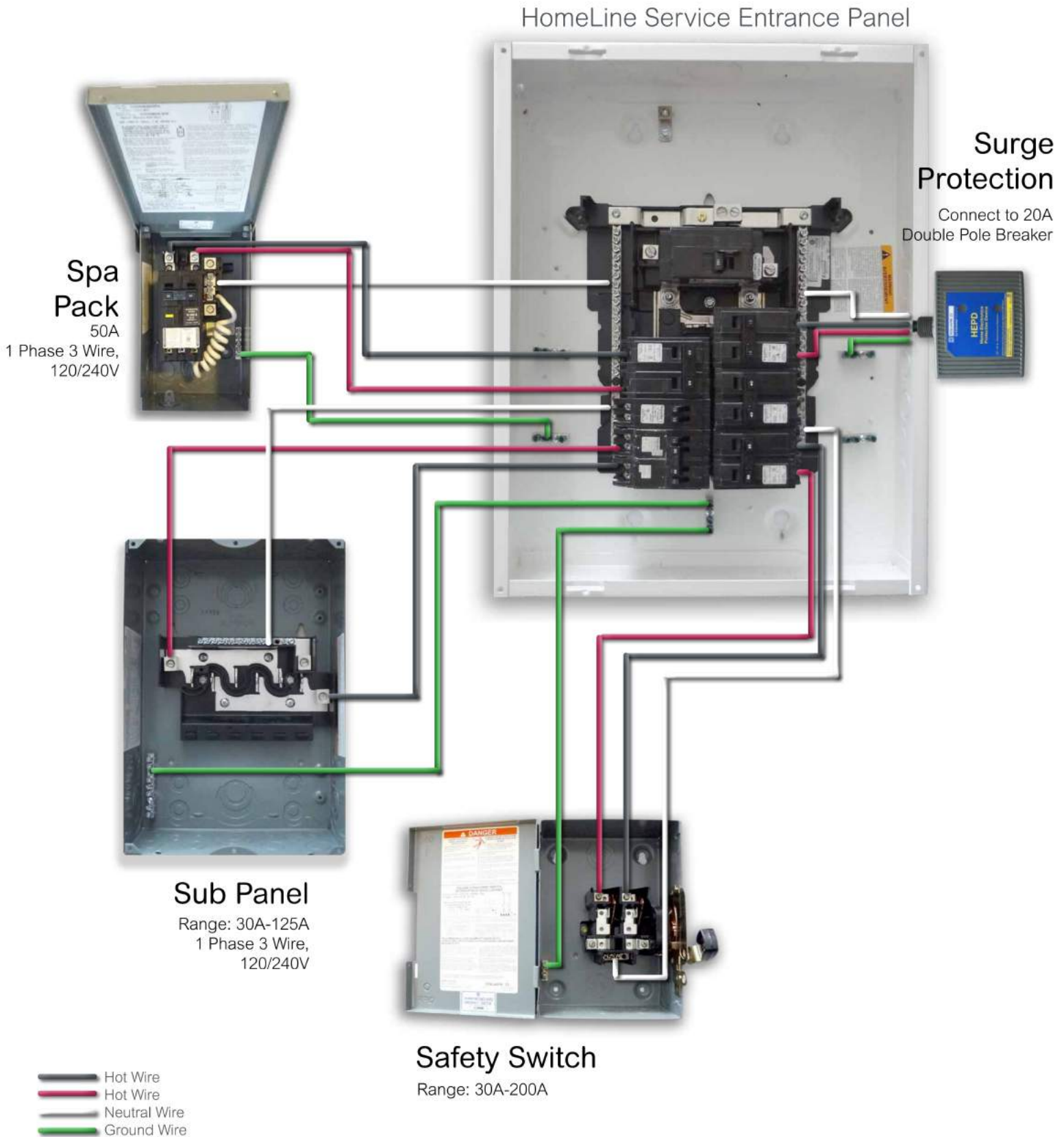

This display is for demo purposes only. Consult a licensed electrician for proper installation of devices. Products not to scale.

# Product Warranty - HomeLine

## A. Limited Warranties

1. Square D HomeLine® brand Single Phase Load Centers and Combination Service Entrance Devices. Square D warrants its HomeLine single phase load centers and combination service entrance devices to be free from defects in material and workmanship, under normal care and proper usage in a residential installation, for a period of ten (10) years from the date of installation. If the product fails within the warranty period because of a defect in material or workmanship, Square D will, at its option, repair or replace the defective part or parts upon following the notice procedures below and return of product to place of purchase.

2. Square D QO® brand Load Centers and Square D Breakers. Square D warrants its branch circuit breakers to be free from defects in material and workmanship under normal care and proper usage in a residential installation, for the lifetime of the load center in which it is installed. QO® brand load center are also covered under the same lifetime warranty. If the circuit breaker or QO® brand load center fails within the warranty period because of a defect in material or workmanship, Square D/Schneider Electric will replace the defective breaker free of charge upon following the notice procedures below and return of the product to place of purchase.

B. Exclusive Remedy — The repair and/or replacement of defective products is your sole and exclusive remedy.

## C. Warranty Redemption and Exclusions —

1. Square D must be given prompt written notice of any defect or failure of any product covered by these limited warranties at the following address:

Schneider Electric - Canadian Returns Centre  
5865 McLaughlin Road, Mississauga, ON L5R1B8, Canada

For warranty redemption, you must return the product to Square D at the above address.

2. Any product returned under these limited warranties, if shipped, must be sent freight costs prepaid. Square D will deliver repaired or replaced products to buyer, freight costs prepaid. Repaired or replaced products shall be warranted here under only for the unexpired portion of the original warranty period. This warranty does not include costs or reimbursement for labor. Any limited warranties granted or liabilities assumed here under will not apply to products that have been damaged, altered, repaired or operated otherwise than in conformity with the requirements for safe operation and maintenance. For your safety and to provide optimum short circuit protection, Square D recommends that you use only the Square D circuit breakers identified on the load center or combination service entrance device label or wiring diagram. Square D disclaims all liability for damage, injury or non-performance caused by the use or failure of incompatible or UL classified circuit breakers.

## D. Disclaimer of All Other Warranties—

EXCEPT FOR THE EXPRESS WARRANTY SET FORTH ABOVE OR ANY WARRANTIES IMPLIED BY LAW, SQUARE D MAKES NO OTHER EXPRESS OR IMPLIED WARRANTIES. TO THE FULLEST EXTENT PERMITTED BY LAW, SQUARE D DISCLAIMS ALL IMPLIED WARRANTIES, INCLUDING ALL WARRANTIES OF MERCHANTABILITY AND/OR FITNESS FOR A PARTICULAR PURPOSE. THE FOREGOING DISCLAIMER MAY NOT APPLY TO YOU DEPENDING UPON THE PRODUCT YOU PURCHASE, THE APPLICATION AND USE OF YOUR PRODUCT, OR YOUR STATUS AS A CONSUMER. TO THE EXTENT YOU ARE ENTITLED TO RECOVER UNDER AN IMPLIED WARRANTY, THE DURATION OF THAT IMPLIED WARRANTY SHALL BE THE PERIOD OF THE EXPRESS LIMITED WARRANTY SET FORTH ABOVE.

E. Limitation of Liability — Square D expressly disclaims any and all liability to you for any consequential or incidental damages, damages for loss of use, loss of profits, income or revenue, loss of time or inconvenience, loss or damage to associated equipment, damages to tangible or intangible property, other than the equipment covered by this limited warranty, cost of substituted or replacement equipment other than as expressly warranted, damages associated with excessive overvoltages, obsolescence, abuse, misuse, non-authorized modification, alteration or catastrophic events, or any other incidental, consequential or special damage arising out of the use of the products. Square D shall not be liable for indirect, special, incidental or consequential damages with respect to the sale of the products, including any lost revenue or profits, consequential and/or incidental damages, business interruption or damage to business reputation, regardless of the theory upon which any claim may be based, of time or inconvenience, loss or damage to associated equipment, damages to tangible or intangible property, other than the equipment covered by this limited warranty, cost of substituted or replacement equipment other than as expressly warranted, damages associated with excessive overvoltages, obsolescence, abuse, misuse, non-authorized modification, alteration or catastrophic events, or any other incidental, consequential or special damage arising out of the use of the products. Square D shall not be liable for indirect, special, incidental or consequential damages with respect to the sale of the products, including any lost revenue or profits, consequential and/or incidental damages, business interruption or damage to business reputation, regardless of the theory upon which any claim may be based, which vary from province to province.

# Product Warranty - Square D

## A. Limited Warranties

Square D brand Loadcentres and Square D QO® brand Circuit Breakers - Schneider Canada warrants its Square D QO® brand branch circuit breakers to be free from defects in material and workmanship under normal care and proper usage in a residential installation, for the lifetime of the loadcentres in which it is installed. QO® brand loadcentres are also covered under the same lifetime warranty. If the QO® brand circuit breaker or QO® brand loadcentre fails within the warranty period because of a defect in material or workmanship, Schneider Canada will replace the defective QO® breaker or QO® loadcentre free of charge upon following the notice procedures below and return of the product to place of purchase.

## B. Exclusive Remedy

The repair and/or replacement of defective products are your sole and exclusive remedy.

## C. Warranty Redemption and Exclusions

1. Schneider Canada must be given prompt written notice of any defect or failure of any product covered by these limited warranties at the following address:

Schneider Electric - Canadian Returns Centre  
5865 McLaughlin Road, Mississauga, ON L5R1B8, Canada

For warranty redemption, you must return the product to Schneider Canada at the above address.

2. Any product returned under these limited warranties, if shipped, must be sent freight costs prepaid. Schneider Canada will deliver repaired or replaced products to buyer, freight costs prepaid. Repaired or replaced products shall be warranted hereunder only for the unexpired portion of the original warranty period. This warranty does not include costs or reimbursement for labour.

Any limited warranties granted or liabilities assumed here under will not apply to products that have been damaged, altered, repaired or operated otherwise than in conformity with the requirements for safe operation and maintenance.

For your safety and to provide optimum short circuit protection, Schneider Canada recommends that you use only the Square D circuit breakers identified on the loadcentre or combination service entrance device label or wiring diagram.

## D. Disclaimer of All Other Warranties

EXCEPT FOR THE EXPRESS WARRANTY SET FORTH ABOVE OR ANY WARRANTIES IMPLIED BY LAW, SCHNEIDER CANADA MAKES NO OTHER EXPRESS OR IMPLIED WARRANTIES. TO THE FULLEST EXTENT PERMITTED BY LAW, SCHNEIDER CANADA DISCLAIMS ALL IMPLIED WARRANTIES, INCLUDING ALL WARRANTIES OF MERCHANTABILITY AND/OR FITNESS FOR A PARTICULAR PURPOSE. THE FOREGOING DISCLAIMER MAY NOT APPLY TO YOU DEPENDING UPON THE PRODUCT YOU PURCHASE, THE APPLICATION AND USE OF YOUR PRODUCT, OR YOUR STATUS AS A CONSUMER. TO THE EXTENT YOU ARE ENTITLED TO RECOVER UNDER AN IMPLIED WARRANTY, THE DURATION OF THAT IMPLIED WARRANTY SHALL BE THE PERIOD OF THE EXPRESS LIMITED WARRANTY SET FORTH ABOVE.

## E. Limitation of Liability

Schneider Canada expressly disclaims any and all liability to you for any consequential or incidental damages, damages for loss of use, loss of profits, income or revenue, loss of time or inconvenience, loss or damage to associated equipment, damages to tangible or intangible property, other than the equipment covered by this limited warranty, cost of substituted or replacement equipment other than as expressly warranted, damages associated with excessive over voltages, obsolescence, abuse, misuse, non-authorized modification, alteration or catastrophic events, or any other incidental, consequential or special damage arising out of the use of the products. Schneider Canada shall not be liable for indirect, special, incidental or consequential damages with respect to the sale of the products, including any lost revenue or profits, consequential and/or incidental damages, business interruption or damage to business reputation, regardless of the theory upon which any claim may be based, including any statutory, tort contract or insurance subrogation causes of action or claims. In no event will Schneider Canada entire liability to you, including any liability in the event the exclusive remedy set forth in this agreement fails of its essential purpose, exceed the purchase price for the affected products.

# Product Warranty - Whole House Surge

## Protection Limits:

With regard to any Square D branded SURGEBREAKER Plus device (catalog numbers SDSB80111, SDSB80111C, SDSB80111CCP) that has been properly installed in a residential home and in compliance with all applicable electrical code requirements, Schneider Electric USA, Inc. ("Schneider Electric") warrants to the homeowner at the time of such installation (or the initial homeowner if installed as part of new construction) that Schneider Electric shall accept responsibility for any damage to that homeowner's connected household equipment that is downstream from the power panel to which the SURGEBREAKER Plus device is connected, up to the limits provided herein, to the extent such damage is caused by the failure of such surge protective device to protect against electrical power surges caused by lightning or a utility company (electric, coaxial or telephone).

As used herein, "connected household equipment" shall mean major household appliances and electronic devices, including refrigerators, freezers, furnaces, air conditioners, stoves, oven, microwave oven, clothes washer, clothes dryer, dishwasher, audio and stereo components, video equipment, televisions and computers. "Connected household equipment" shall exclude any commercial or industrial grade equipment not commonly found in a home.

The limit of Schneider Electric's liability under this limited warranty shall be the lesser of \$100,000 or the deductible amount of customer's insurance policy covering such connected household equipment, except that when the SURGEBREAKER Plus device does not have coaxial or telephone modules installed in the SURGEBREAKER Plus device or those modules are not connected to equipment. Then the limit of Schneider Electric's liability under this limited warranty shall be the lesser of \$50,000 or the deductible amount of customer's insurance policy covering such connected household equipment.

## Limited Warranty Period

This limited warranty shall be in effect for five (5) years following the date of purchase of the SURGEBREAKER Plus device, except that when the SURGEBREAKER Plus device does not have coaxial or telephone modules installed in the SURGEBREAKER Plus device or those modules are not connected to equipment. Then this limited warranty shall be in effect for three (3) years following the date of purchase of the SURGEBREAKER Plus device.

## Limited Warranty Not Transferable

This limited warranty may not be transferred from the homeowner who initially receives this limited warranty to any other party.

## Limited Warranty Limitations

THIS LIMITED WARRANTY IS EXCLUSIVE AND IN LIEU OF ALL OTHER EXPRESS OR IMPLIED WARRANTIES, INCLUDING WITHOUT LIMITATION ANY IMPLIED WARRANTIES OF MERCHANTABILITY OR OF FITNESS FOR A PARTICULAR PURPOSE.

This limited warranty excludes damage or loss arising from any of the following events or sources: unauthorized product modification or alteration, vandalism, theft, normal-use wear and tear, erosion, depletion, obsolescence, abuse, defective software, and computer virus infection and force majeure events such as flood, earthquake or other acts of God, war, insurrection.

NOTWITHSTANDING ANYTHING TO THE CONTRARY CONTAINED HEREIN, SCHNEIDER ELECTRIC, ITS AFFILIATES, OR SUBSIDIARIES SHALL NOT BE LIABLE FOR ANY INDIRECT, INCIDENTAL, CONSEQUENTIAL DAMAGES WHATSOEVER.

With respect to products purchased by consumers in the United States for personal use, implied warranties, including but not limited to the warranties of merchantability and fitness for a particular purpose, are not excluded but are limited to the extent allowed by law to the duration of the limited warranty period set forth above. No claim under this limited warranty will be honored unless the homeowner has reported the damage within thirty (30) days after its occurrence in accordance with the claims procedure below.

## Claims Procedure

To make a claim under this limited warranty please follow these steps: (1) Retain the original dated sales receipts from the SURGEBREAKER Plus device. (2) Ask an independent repair person to write a report on the cause of the damage. Retain all related repair receipts. (3) File a claim under homeowner's insurance. (4) Within thirty (30) days of the occurrence of the damage and prior to repairing the damaged equipment, contact Schneider Electric at (800) 877-1174, Monday through Friday 8:00 a.m. to 4:30 p.m. Mountain Time. (6) Send the purchase receipt, repair receipt, damage report, and any homeowners insurance report along with the damaged SURGEBREAKER Plus component(s) (electrical, telephone and/or coaxial cable) to: Schneider Electric, 1751 South 4800 West, Salt Lake City, Utah 84104, Attn: SURGEBREAKER Plus LIMITED WARRANTY. Failure to follow the claims procedure set forth above may be grounds for refusing any limited warranty claim made hereunder.

# Residential Products

## RESIDENTIAL CONSTRUCTION

Schneider Electric is the global specialist in energy management and automation. Our 160,000+ employees serve customers in over 100 countries, helping them to manage their energy and process in ways that are safe, reliable, efficient and sustainable. From the simplest of switches to complex operational systems, our technology, software and services improve the way our customers manage and automate their operations. Schneider Electric is the parent company of the Square D and Federal Pioneer brands and produces the HomeLine line of residential products

Life Is On



### HomeLine™

HomeLine™ loadcentres were first introduced in North America in 1989 and through innovative solutions, it quickly became the reference for electrical distribution products to the residential market. In Canada, Homeline provides reliable and safe loadcentres, sub panels and circuit breakers for all residential needs.

Life Is On



Powering you to succeed. Square D provides residential builders, commercial and industrial facilities with the infrastructure needed to operate effectively and efficiently. Our electrical distribution, industrial control and automation products, systems and services provide smart solutions and proven performance enabling our customers to provide the very best to their clients.

### Federal Pioneer™

As part of the Schneider Electric portfolio since 1990, Federal Pioneer products have been serving industrial companies, electrical equipment distributors and homes for more than 50 years.



Have Questions?

Call Schneider Electric Customer Service at 1-800-565-6699

Schneider Electric Canada, Inc.

5985 McLaughlin Road  
Mississauga, ON L5R 1B8  
Tel: 1-800-565-6699  
[www.se.com/ca](http://www.se.com/ca)

Document Number S1100CT1109EP R23