

# BENCHMARK<sup>TM</sup> MC

## 22" ELECTRIC SNOW BLOWER



5 Year Limited Warranty



**READ ALL INSTRUCTIONS BEFORE FIRST USE.  
KEEP THIS MANUAL FOR FUTURE REFERENCE.  
KEEP AWAY FROM CHILDREN.**



**WEAR CSA APPROVED  
EYE PROTECTION**



**WEAR EAR  
PROTECTION**



**WEAR A  
FACE MASK**

## PRODUCT SPECIFICATIONS

22" SNOW BLOWER	
Motor	120 V, 60 Hz, 15 A
Paddle speed	Up to 2,500 RPM
Clearing width	22" (56 cm)
Clearing depth	12" (30 cm)
Discharge distance	Up to 30' (9 m)
Plowing capacity (Max)	25 tons (25,000 kg) per hour
LED light	3 W
Impeller size	8" (20 cm)
Wheels	7" (18 cm)
Weight	36 lb 8 oz (16.68 kg)

### NEED ASSISTANCE?

For problems or questions, **DO NOT RETURN TO STORE**. Please contact one of our Customer Service Agents who would be happy to assist you.

For Customer Assistance Please Call: 1-833-818-4111.

**TABLE OF CONTENTS**

Product Specifications ..... 1  
Table of Contents ..... 2  
Safety Information ..... 3-5  
Electrical ..... 5-6  
Assembly ..... 7-9  
Operation ..... 10-12  
Maintenance ..... 12-14  
Safety Symbols ..... 15-16  
Know your 22" Snow Blower ..... 17-18  
Troubleshooting ..... 18  
Exploded View ..... 19  
Parts List ..... 20-21  
Warranty ..... 22

## SAFETY INFORMATION

### FOLLOW THESE RULES WHILE OPERATING THE SNOW BLOWER

Walk. Do not run.

- Verify that the snow blower is not in contact with anything before turning it on.
- Stay away from paddle openings at all times. Keep face, hands, and feet away from concealed, moving, or rotating parts.
- Be attentive when using the snow blower. Stay alert for holes in the terrain and other hidden hazards or traffic.
- Move up and down slopes when clearing snow. Do not go across a slope. Use caution when changing direction. Do not use this snow blower to clear snow from steep slopes.
- Do not operate the power tool if the guards, plates, and other safety protective devices are not in place.
- Do not operate the snow blower near glass enclosures, automobiles, trucks, window wells, drop-offs, etc., without properly adjusting the angle of the snow discharge. Keep children and pets away from the work area.
- Do not operate the snow blower at high speeds on slippery surfaces. Look behind when backing up and exercise caution.
- Wear safety glasses or goggles that meet ANSI 287.1 standards.
- Use the snow blower in daylight or in good artificial light.
- To avoid accidental start-ups, remain in the starting position when turning the snow blower on. The operator and the power tool must be in a stable position during start-up. See the section titled Powering On and Off, page 12.
- Use this power tool only for the purposes it was designed.
- Hold the snow blower with both hands while it is in use. Keep a firm grip on the handles.
- If the impeller does not rotate freely due to ice, thaw the snow blower thoroughly before attempting to use it.
- Keep the paddle clear of debris.
- Do not attempt to clear the impeller while the motor is running.
- If the snow blower starts to vibrate abnormally, stop the snow blower immediately and attempt to determine the cause. Vibration is generally an indication of danger.
- Do not use on gravelled surface unless the snow blower is adjusted for such a surface in accordance with the operator's manual.
- Keep Children Away-All visitors should be kept a safe distance from work area.
- Dress Properly- Do not wear loose clothing or jewellery. They can be caught in moving parts.
- Wear rubber boots when operating the snow blower. Always wear substantial footwear.

**⚠️ WARNING! Read the operating and service instruction manual carefully. Be thoroughly familiar with the controls and the proper use of the equipment.**

- Keep guards in place and in working order.
- Don't force the snow blower - It will perform better and safer at the rate for which it was designed.
- Don't overreach - Keep proper footing and balance at all times.
- If the snow blower strikes a foreign object, follow these steps:
  - i) Stop the snow blower. Release the switch.
  - ii) Unplug power cord.
  - iii) Inspect for damage.
  - iv) Repair any damage before restarting and operating the snow blower.
- Store snow blower indoors -When not in use, power tools should be stored indoors in a dry, locked-up place out of reach of children.
- Maintain snow blower with care - Follow instructions for lubricating and changing accessories.
- Allow the snow blower to run for a few minutes after clearing snow in order to prevent moving parts from freezing.
- Only use identical replacement parts and accessories for this snow blower. The use of nonidentical or accessories could lead to serious injury to the user or damage the snow blower, and will void the warranty.
- Do not pick up the snow blower while it is running. The snow blower is designed to travel along the ground.
- Never allow children to operate a snow blower. Keep the area of operation clear of all persons, particularly small children, and pets.
- Thoroughly inspect the area where the equipment is to be used and remove all stones, sticks, wires, bones, and other foreign objects.
- Stop the paddle when crossing gravel driveways, walkways, or roads.
- To prevent disconnection of the power cord from the extension cord during operation. Refer to the section entitled Using the Cord Retainer.
- Avoid accidental starting - Don't carry a plugged in snow blower with your finger on the switch. Be sure switch is off when plugging in.
- If the cord is damaged in any manner while it is plugged in, disconnect it from the outlet immediately.
- Do not abuse the cord. Do not carry the snow blower by the power cord or yank the cord in order to disconnect it from the receptacle.
- Disconnect the snow blower from the power supply when: not in use, before servicing, and when changing accessories.

## **GENERAL SAFETY RULES**

- Verify that the snow blower is secure while transporting.
- Store the snow blower in a dry area that will prevent unauthorized use or damage. Keep out of the reach of children.
- Keep handles dry, clean, and free of debris. Clean the snow blower after each use. Refer to Maintenance section in this manual for more information.
- If the labels on the snow blower become defaced or start to lift off, contact the toll-free helpline at 1-833-818-4111.

- Keep these instructions in a safe place for future reference. Refer to them often, and use them to instruct other users. Anyone who uses this snow blower must read these instructions carefully.
- Maintain the snow blower with care. Follow the instructions for lubricating and changing accessories.

**⚠️ WARNING! To prevent electric shock use only with an extension cord suitable for outdoor use.**

## ELECTRICAL

### DOUBLE INSULATION

Double insulation is a concept in safety in electric snow blower which eliminates the need for the usual three-wire grounded power cord. All exposed metal parts are isolated from the internal metal motor components with protecting insulation. Double insulated snow blowers do not need to be grounded.

**⚠️ WARNING! Servicing of a product with double insulation requires extreme care and knowledge of the system and should be performed only by a qualified service technician.**

**For service, we suggest you return the product to your nearest authorized service centre for repair. Always use identical factory replacement parts when servicing.**

### EXTENSION CORDS

When using a snow blower at a considerable distance from a power source, be sure to use an extension cord that has the capacity to handle the current the product will draw. An undersized cord will cause a drop in line voltage, resulting in overheating and loss of power. Use the chart to determine the minimum wire size required in an extension cord. Only round jacketed cords listed by Underwriter's Laboratories (UL) should be used.

MINIMUM GAUGE (AWG) EXTENSION CORDS (120V USE ONLY)			
Ampere Rating* (on product data plate)	Cord Length		
	25' (7.6 m)	50' (15 m)	100' (30 m)
0-2.0	16	16	16
2.1-3.4	16	16	16
3.5-5.0	16	16	14
5.1-7.0	16	14	12
7.1-12.0	14	14	12
12.1-16.0	14	12	-

\*Used on 12 gauge - 20 amp circuit. NOTE: AWG = American Wire Gauge

When working outdoors with a product, use an extension cord that is designed for outside use. This type of cord is designated with "WM" on the cord's jacket.

Before using any extension cord, inspect it for loose or exposed wires and cut or worn insulation. It is possible to tie the extension cord and power cord in a knot to prevent them from becoming disconnected during use. Make the knot as shown in the figure at right, then connect the plug end of the power cord into the receptacle end of the extension cord. This method can also be used to tie two extension cords together.

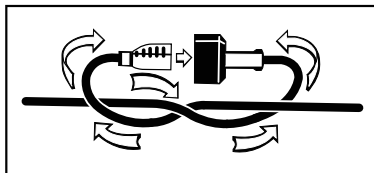

**⚠ WARNING! The double-insulated system is intended to protect the user from shock resulting from a break in the snow blower's internal insulation. Observe all normal safety precautions to avoid electrical shock.**

- Inspect the extension cord and the power cord on a regular basis. Look for deterioration, cuts, or cracks in the insulation. Inspect the connections for damage. Repair or replace the extension cord or the power cord if any damage is found.
- Verify that the paddle and all moving parts have come to a complete stop, and disconnect the snow blower from the power supply in order to prevent accidental start-ups, before cleaning or performing any inspections or repairs.
- Do not abuse the extension cord. Do not carry the snow blower by the power cord or pull on the cord in order to disconnect it from the receptacle.
- Keep the extension cord away from heat, oil, and sharp edges in order to prevent damage.
- If the extension cord is damaged in any manner while it is plugged in, disconnect it from the outlet immediately.
- Prevent any possible disconnection of the power cord from the extension cord while the snow blower is in use by using the cord retainer. Refer to the section entitled Using the Cord Retainer.
- Unplug the snow blower and allow it to cool down before putting it into storage. Store the snow blower indoors.
- Unplug the snow blower when it is not in use and before performing any maintenance or repairs.

**⚠ WARNING! Keep the extension cord clear of the working area. Position the cord so that it will not get caught on obstacles while you are operating the snow blower. Failure to do so can result in serious personal injury.**

## ASSEMBLY

### GETTING STARTED

1. Remove the snow blower and all other items from the box.
2. Determine the left and right hand side of the snow blower by standing in the normal operating position.
3. Check all items for shipping damage. If damage is found or suspected or if any of the parts are missing, do not assemble. Instead, promptly inform the dealer where you bought the snow blower or contact at 1-833-818-4111 for assistance.
4. Check to make sure the upper chute crank is included.

### ASSEMBLING THE HANDLE

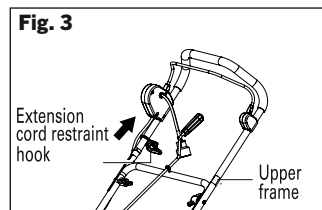
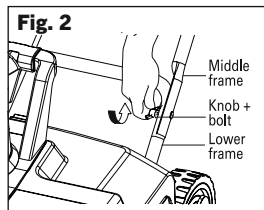
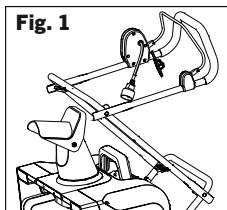

1. For easy assembly, the unit comes complete with most parts already connected. To complete the handle assembly, please follow the steps below. For storage, you can fold the handle as (Fig. 1 ).
2. Secure the connection of the lower frame to the middle frame by fastening the first set of joint fixing T-bolts and knobs on each side.
3. Before securing the upper frame, slide the extension cord restraint hook up the upper frame (Fig. 3).
4. Secure the connection of the upper frame to the middle frame by fastening the second set knobs and bolts on each side (Fig. 4).

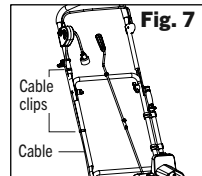
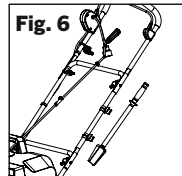
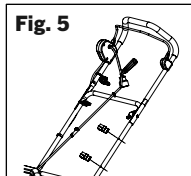
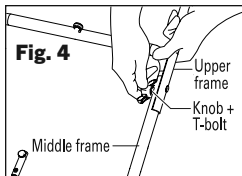

5. Clip the 2 chute clean-out tool clips on the side of the middle frame, and insert the chute clean-out tool in the clips (Figs. 5 - 6).
6. Clip on the 2 cable clips on the frame, and insert the cable inside of the cable clips (Fig. 7).



## DISCHARGE CHUTE ASSEMBLY

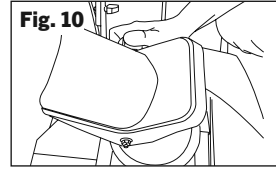
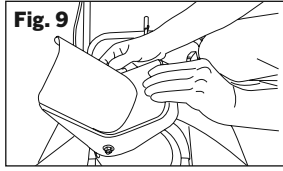
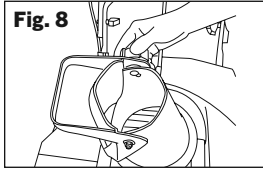

1. Loosen the knob to lift the chute deflector.
2. Lift the chute deflector and lock it securely onto the discharge chute.
3. Raise or lower the chute deflector to the desired height of the snow stream and tighten the knob. **NOTE!** Do not overtighten the knob.

## CHUTE CRANK ASSEMBLY

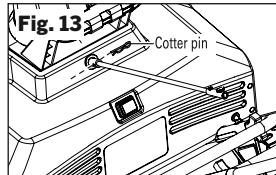
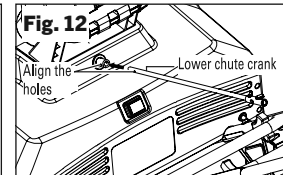
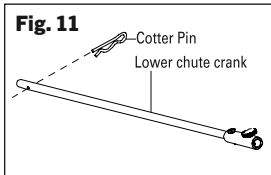

1. Remove the cotter pin from the lower chute crank (Fig. 11).
2. Install the lower crank rod by inserting it into the opening at the back of the housing with holes aligned (Fig. 12).
3. Secure the lower chute crank in place with the cotter pin (Fig. 13).

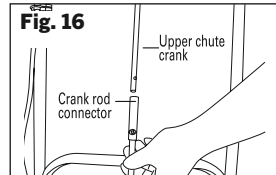
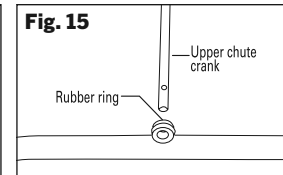
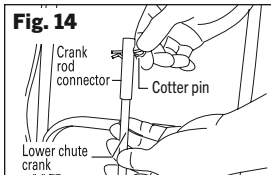

4. Remove the cotter pin on the crank rod connector by hand (Fig. 14).
5. Slide the upper chute crank through the rubber ring located on the middle frame (Fig. 15).
6. Slide the upper chute crank into the crank rod connector (Fig. 16).
7. Align the holes and insert the cotter pin by hand (Fig. 17).

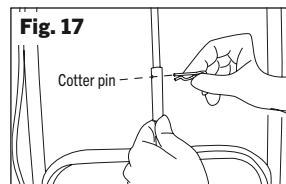

**NOTE:** Before using this machine, make sure that the power source you will use complies with the specifications detailed in this manual. Before inserting the plug into the socket, verify that the snow blower's roll shaft and rubber plates are firmly secured with screws, and that the rubber plates are firmly secured with screws, and that the rubber plates are facing the correct direction. Perform a test run to ensure that the motor turns freely.

## SECURING THE EXTENSION CORD

**⚠ WARNING! Electric shock may cause SEVERE INJURY or DEATH.**

- Do not allow any part of snow blower to make contact with water while powered on. If the snow blower becomes wet while turned off, wipe dry before starting.
- Use only a UL, CSA, or ETL rated extension cord for outdoor, all weather use. Do not use an extension cord over 100 ft (30 m).
- Do not touch the appliance or its plug with wet hands or while standing in water. Wearing rubber boots offers some protection.

### EXTENSION CORD CHART

Cord Length	50 ft (15 m)	100 ft (30 m)
Wire Gauge	14 AWG	12 AWG

1. For safe and efficient use of your snow blower, use only a UL-rated extension cord recommended for outdoor use.

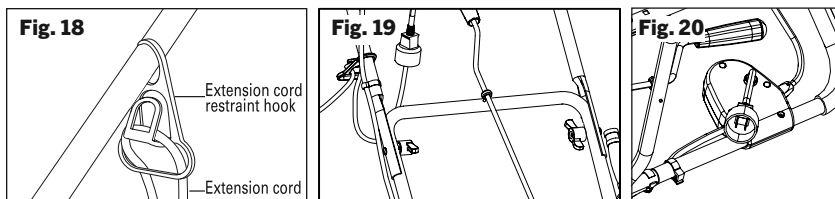

2. Push the loop of the extension cord through the slot from the opposite side of the restraint hook. Position the loop over the hook and pull the cable back through the slot (Fig. 18).
3. Insert the female end of the extension cord into the appliance's polarized male plug (Fig. 19).
4. Note that the snow blower has a polarized male plug—one prong in the plug is slightly longer and wider than the other (Fig. 20). The extension cord female end should be likewise polarized so that the extension cord fits snugly into the snow blower plug.

**⚠ WARNING! Damaged electrical cords present risk of fire, electrical shock, and serious bodily injury. Before operating the snow blower, carefully examine the electrical cord. If the cord is damaged, do not use the snow blower. Replace or repair the damaged cord immediately.**

## OPERATION

### POWERING ON AND OFF

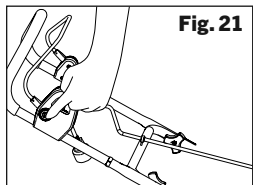

Fig. 21

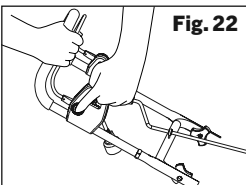

Fig. 22

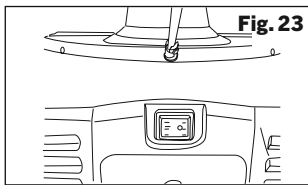

Fig. 23

1. To power on, depress and hold the safety switch button found alongside the switch housing (Fig. 21).
2. While depressing the safety switch button, pull the ON/OFF switch bail toward you. Once the machine powers on, release the safety switch button and begin operation (Fig. 22). The machine can only be started by depressing the safety switch button first, followed by squeezing the ON/OFF switch bail; reverse operation will not start the machine.
3. To power off, release your grip on the ON/OFF switch bail.
4. The LED light can be used to illuminate the surface in front in the dark. To use the light, turn on the light switch located on the back side of the snow blower (Fig. 23).

**⚠ NOTE: The light will only turn ON when the snow blower is running. After finishing your work session, REMEMBER to TURN OFF the light switch.**

### MOVING THE MACHINE & PLOWING THE SNOW

**⚠ WARNING! Foreign objects, such as rocks, broken glass, nails, wire, or string, can be picked up and thrown by the snow blower, causing serious personal injury. Remove all foreign objects from the area to be plowed before operating the snow blower.**

1. Keep the area of operation free of foreign objects that can become thrown by the rotating paddle. Perform a thorough inspection of the area since some objects may be hidden from view by surrounding snow. If the snow blower hits an obstruction or picks up a foreign object during use, stop the snow blower, disconnect the extension cord, remove the obstruction, and inspect the unit for damage. Repair or replace any damaged part before restarting and operating the unit.
2. Keep children, pets, and bystanders away from the area of operation. Be aware that the normal noise of the machine when turned on may make it difficult for you to hear approaching people.
3. When moving the snow blower, use the wheels on one side as the pivot point. Slightly tilt the snow blower on this pivot point to move it forward or backward.
4. Start your clearing path near the electrical outlet and work outward, throwing snow in a back and forth motion. To clear in the opposite direction, step over the cord and pivot the snow blower on its wheels. Make sure to overlap clearing paths.

5. Note the wind direction. If possible, move in the same direction as the wind so that the snow is not thrown against the wind (and then back into your face and onto the just cleared path).
6. While moving the snow blower, do not drag the power cable violently or roughly. The snow blower should move within the range that the cable can reach.
7. Do not push the snow blower with excessive force. You should push the machine gently and evenly in accordance with the unit's throw rate.
8. Do not apply additional man-made load to the engine since this may cause engine damage.
9. Some parts of the snow blower may freeze under extreme temperature conditions. Do not attempt to operate the snow blower with frozen parts. If the parts freeze while the snow blower is in use, stop the snow blower, unplug the extension cord, and inspect for frozen parts. Free all parts before restarting or operating the snow blower. Never force controls that have frozen.
10. When working on pebbles, gravel, or unpaved surfaces, avoid throwing loose surface material along with the snow by pushing down on the handle to raise the scraper bar at the base of the unit above the pebbles or gravel.

## CHANGING THROW DIRECTION AND THROW HEIGHT

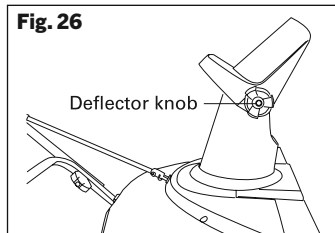
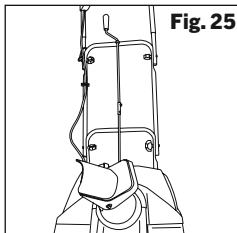
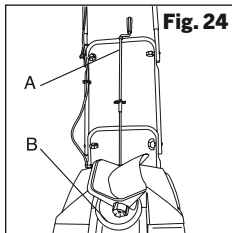

1. The discharge chute can be adjusted 180 degrees by rotating the chute crank. Rotate the chute control crank clockwise to move the discharge chute to the left (Fig.24) and counterclockwise to move the chute to the right (Fig.25).

**⚠️ NOTE: A little lubricant, such as WD-40, will provide a smoother operation of the chute (spray at points A and B as indicated in Fig. 24).**

2. The chute deflector on the top of the discharge chute controls the height of the snow stream. Loosen the knob to raise or lower the deflector to the desired height of snow you wish to throw. Tighten the knob to secure the deflector (Fig. 26).

**⚠️ WARNING! Never direct the snow discharge chute at the operator, at bystanders, at vehicles, or at nearby windows. The discharged snow and foreign objects accidentally picked up by the snow blower can cause serious damage and personal injury. Always orient the discharge chute in the opposite direction from where you, bystanders, surrounding vehicles, or windows are located.**

**⚠ WARNING! Make sure that the chute deflector snaps and locks completely onto the discharge chute. An opening between the discharge chute and the chute deflector may allow foreign objects to be picked up by the snow blower and thrown in the direction of the operator causing serious bodily injury. Do not advance the chute deflector too far forward causing an opening to appear between the deflector and discharge chute. Do not overtighten the knobs on the chute deflector (Fig. 26).**

## MAINTENANCE

### SERVICING

Servicing should be performed by a qualified technician. Replacement parts for this snow blower must be identical to the parts that they replace. If repairs are necessary, contact the toll-free helpline at: 1-833-818-4111.

### STORAGE

- Allow the engine to cool completely before cleaning, storing, or transporting the snow blower. Be sure to secure the unit while transporting.
- Disconnect the extension cord from the snow blower. Inspect the extension cord closely for signs of wear or damage. Replace it if it is worn or damaged.
- Run the snow blower for a few minutes in order to melt any snow that may be left on the snow blower.
- Wipe the snow blower off with a dry cloth before storage. This will help prevent ice building up on the unit and parts freezing.
- Inspect the snow blower thoroughly for worn, loose, or damaged parts. If any parts must be repaired or replaced, contact the toll-free helpline at: 1-833-818-4111.
- Store the snow blower in a clean, dry place. Cover it in order to provide added protection.

**⚠ NOTE: Identify the left and right sides of the snow blower when standing in the normal operating position.**

### LIFETIME LUBRICATION (MOTOR AND PADDLE)

Lubrication is not necessary and may damage the unit. The snow blower is lubricated for lifetime use at the factory before shipment.

### GENERAL MAINTENANCE TIPS

1. Do not attempt to repair the machine unless you have the proper tools and instructions for disassembly and repair of the machine.
2. Check bolts and screws at frequent intervals for proper tightness to ensure that the equipment is in safe working condition.
3. After each snow removal session, run the snow blower for a few minutes to prevent the collector/paddle from freezing. Shut off the motor, wait for all revolving parts to stop completely, and wipe residual ice and snow off the unit. Rotate the chute crank several times to remove any excess snow.

## REPLACING THE RUBBER PLATES

**⚠️ NOTE:** When replacing worn rubber plates, pay close attention to carefully distinguish between the coarse and smooth side of the plates. Place the coarse side inside and the smooth side outside.

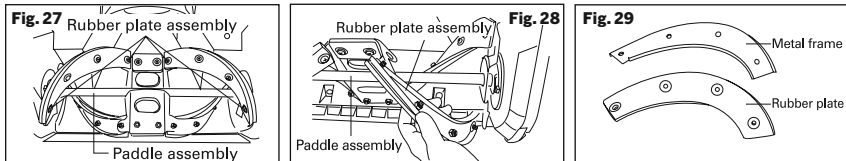

1. Detach the worn rubber plate assembly by removing the two sets of nuts and bolts used to secure it to the paddle assembly (Figs. 27 & 28).
2. Loosen the middle two sets of nuts and bolts to detach the worn rubber plate from the metal frame (Fig. 29).
3. Attach the new rubber plate onto the metal frame by replacing and tightening the middle two sets of nuts and bolts (Fig. 29).
4. Reassemble the rubber plate assembly to the paddle assembly by replacing and tightening the two sets of nuts and bolts used to secure it.

**⚠️ WARNING!** Make sure to turn off the switch and disconnect the extension cord before performing any maintenance task on your snow blower.

## REPLACING THE RUBBER PLATES

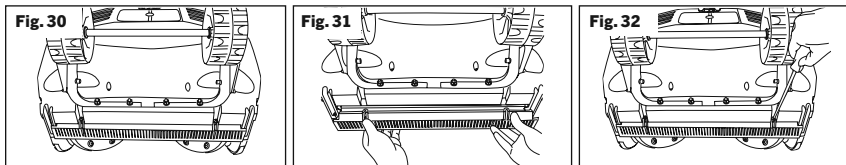

1. The scraper bar is located at the base of the snow blower beneath the rotor housing (Fig.30).
2. Detach the worn scraper bar from the snow blower by removing the two screws that hold it in place (Fig. 31 ).
3. Install the new scraper bar and fasten it securely to the snow blower with the two screws (Fig. 32).

## REPLACING THE BELT AND PULLEY

**⚠️ NOTE:** Determine the left and right hand side of the snow blower by standing behind the unit in the normal operating position.

1. Remove the screws from the left panel of the snow blower and remove the left panel (Fig. 33).
2. Lift the belt tension pulley and roll the worn belt up and off the big pulley from the top of the big pulley (Fig. 34).

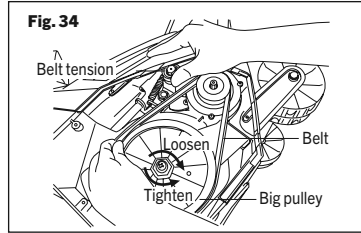
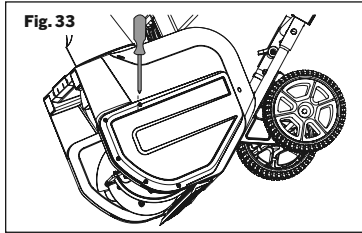

3. To replace the big pulley, remove the screw and washer from the middle of the pulley. While securing the paddle, so it does not spin, use a 7/8-inch socket to turn the outer nut of the pulley clockwise (the pulley is left-handed, so loosening and tightening occur in reverse orientation; clockwise to loosen and counterclockwise to tighten). Once the old pulley is removed, replace the big pulley and tighten the outer nut counterclockwise with the 7/8-inch socket. Replace and tighten the screw and washer (Fig. 34).











**⚠ NOTE: Heavy wet snow puts a load on belts, thus requiring more frequent belt replacement.**

4. To install the new belt, lift the belt tension and roll the new belt onto the little pulley at an angle. Then roll the belt onto the top of big pulley by rotating the big pulley counterclockwise as the belt grips the top of the big pulley (Fig. 34).
5. Replace the left panel of the snow blower with all screws (Fig. 33).





### AUTOMATIC RESET

This snow blower has built-in automatic reset functions. In the event of a major obstruction that halts paddle movement, simply unplug your unit, clear the paddle obstruction, wait 60 seconds, and then resume use of your machine.

## SAFETY SYMBOLS

<b>V</b>	Voltage
<b>A</b>	Current
<b>Hz</b>	Frequency (cycles per second)
<b>W</b>	Power
<b>min</b>	Time
<b>no</b>	Rational speed, at no load.
	Double-insulated construction.
<b>/min</b>	Revolutions, strokes, surface speed, orbits etc., per minute.
	SAFETY ALERT - Indicates a precaution, a warning, or a danger.
	WARNING! Do not expose the unit to rain or wet conditions. Keep dry.
	To reduce the risk of injury user must read and understand operator's manual before using this product.
 	Always wear safety goggles or safety glasses with side shields, and as necessary a full face shield as well as full ear protection when operating this product.
	Stop the machine before leaving the machine. The rotating part will continuously run for several seconds after you turn off the machine.
	Thrown objects can ricochet and result in personal injury or property damage.
	Danger-Keep hands and feet away from openings while the machine is running. Do not use hands to unclog chute. Stop motor and unplug the machine before removing debris.
	Keep all bystanders and domestic animals a safe distance away from the work area.
	Keep hands away from moving parts.
	Keep hands and feet away from rotating parts.
	Keep hands away from the moving parts of the snow blower. The rotating parts can cause severe bodily injury.



	<p>Always keep the power cable away from heat sources, oils, or sharp edges. Immediately remove plug from the mains if the cable is damaged or entangled.</p>
	<p>Wear safety gloves during use to protect hands. Wear safety footwear at all times to provide protection against objects that may accidentally fall on feet.</p>
	<p>WARNING! Electrical shock hazard.</p>
	<p>Keep the flexible power supply cord away from the rotating paddle.</p>
	<p>WARNING! Turn the machine OFF and disconnect it from the power supply before inspecting, cleaning, changing accessories or conducting any other maintenance task.</p>

## KNOW YOUR 22" ELECTRIC SNOW BLOWER

- Carefully remove the product and any accessories from the box. Make sure that all items listed in the packing list are included.
- Inspect the product carefully to make sure no breakage or damage occurred during shipping.
- Do not discard the packing material until you have carefully inspected and satisfactorily operated the product.
- If any parts are damaged or missing, please call 1-833-818-4111 for assistance.

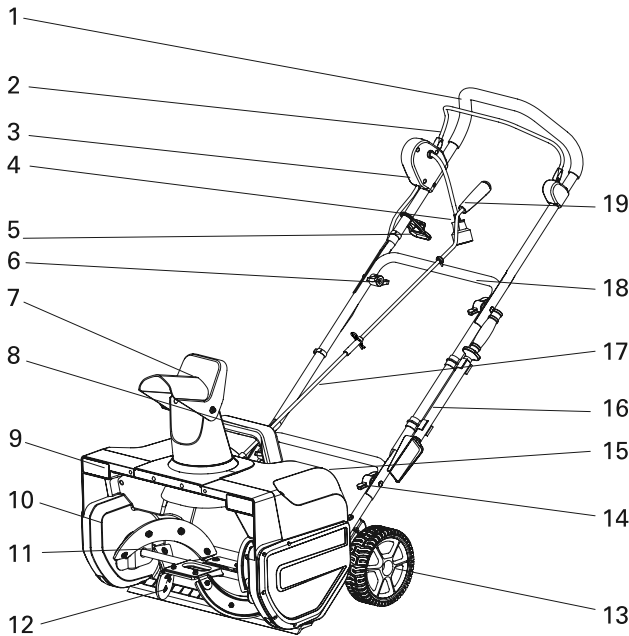

- |  |                          |
|--|--------------------------|
| 1. Handle bar                                      | 11. Paddle               |
| 2. Bail lever                                      | 12. Scraper bar          |
| 3. Safety switch button                            | 13. Wheel                |
| 4. Power cord                                      | 14. Lower frame          |
| 5. Cable restraint holder                          | 15. LED light switch     |
| 6. Joint fixing t-bolt & knob- 4 pieces            | 16. Chute clean-out tool |
| 7. Discharge chute                                 | 17. Lower chute crank    |
| 8. Carrying or lifting handle (For transport only) | 18. Middle frame         |
| 9. LED light                                       | 19. Upper chute crank    |
| 10. Main cover                                     |                          |

**⚠️ WARNING!** If any parts are damaged or missing, do not operate this product until the parts are replaced. Using a product with damaged or missing parts could result in serious personal injury.

**⚠️ WARNING!** Do not attempt to modify this product or create accessories not recommended for use with this product. Any such alteration or modification is misuse and could result in a hazardous condition leading to possible serious personal injury.

## TROUBLESHOOTING

PROBLEM	POSSIBLE CAUSE	SOLUTION
The handle is not in position.	The bolts are not properly seated.	Make sure the bolts are correctly installed through the handlebars. Check to see if the hand knobs are tight. Refer to Assembling the Handle, page 9.
The snow blower does not start.	The switch is defective. The extension cord is not connected to the plug. The extension cord is not connected to the power source.	Have the switch replaced by an authorized service centre. Connect the plug on the snow blower to the extension cord. Plug the extension cord into a live 120VAC, 60 Hz outlet.
The motor is on, but the impeller does not turn.	The belt is damaged.	Replace the belt. Refer to Replacing the Belt and Pulley, page 15.
The snow blower leaves a thin layer of snow behind.	The scraper is worn.	Inspect the scraper for wear or damage. Replace the scraper. Refer to Replacing the Scraper Bar, page 15.

## EXPLODED VIEW

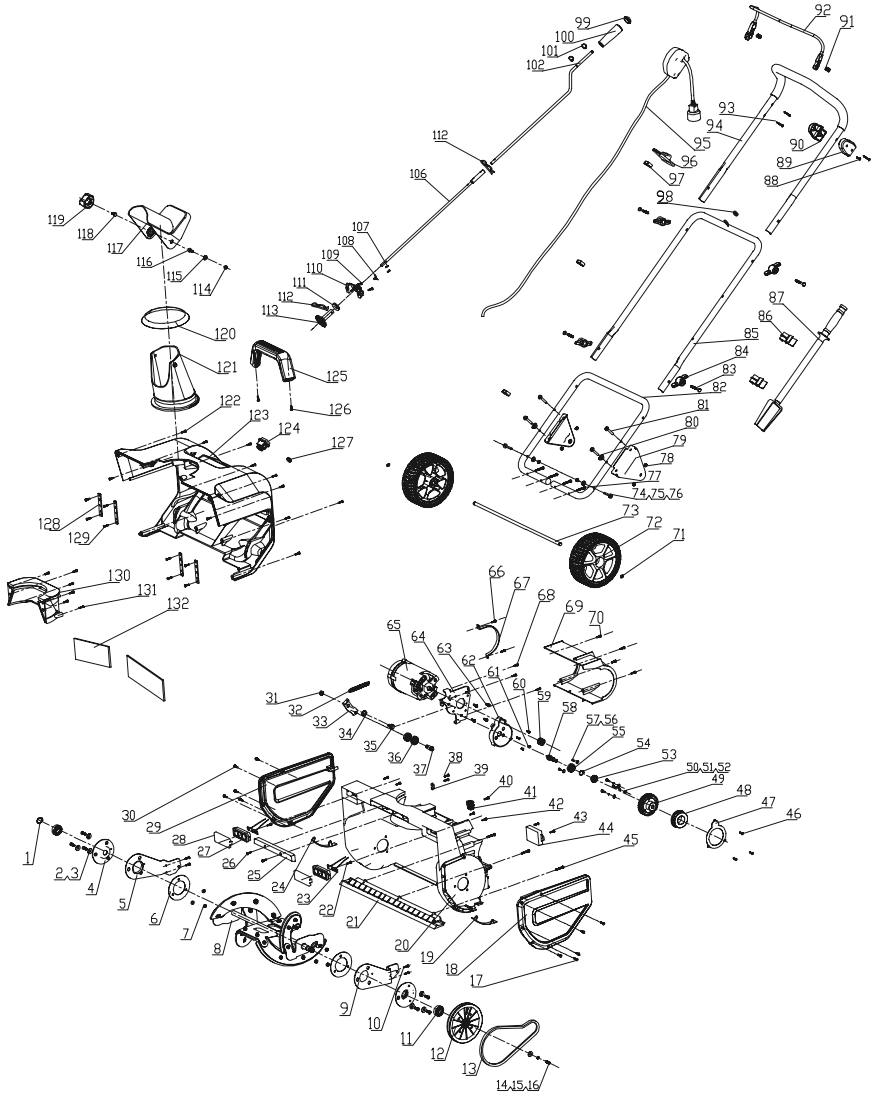

**PARTS LIST**

NO.	NAME	QTY	NO.	NAME	QTY
1	CIRCLIP	1	33	TENSION BRACKET	1
2	PAN HEAD SCREW M6X18	6	34	FLAT WASHER	1
3	SMALL WASHER	6	35	TENSION SUPPORT	1
4	BEARING SEAT	2	36	6001-Z BEARING	2
5	RIGHT CONNECTING SUPPORT	1	37	TENSION WHEEL AXLE	1
6	PRESS PLATE	2	38	SELF TAPPING SCREW ST4.2X16	2
7	M6NUT	6	39	WIRE PRESS BLOCK	1
8	AUGER ASSEMBLY	1	40	SELF TAPPING SCREW ST4.2X13	1
9	LEFT CONNECTING SUPPORT	1	41	SELF TAPPING SCREW ST4.2X16	1
10	SELF TAPPING SCREW ST4.2X16	4	42	SCREW	4
11	6202-Z BEARING	2	43	CABLE PRESSURE PLATE	2
12	V-BELT WHEEL	1	44	TERMINAL BLOCK	1
13	V-BELT	1	45	SELF TAPPING SCREW ST4.8X30	3
14	LARGE WASHER	1	46	SELF TAPPING SCREW ST3.5X13	3
15	SPRING WASHER	1	47	SELF TAPPING SCREW ST4.2X16	1
16	PAN HEAD SCREW M6X16	1	48	CORD SHEATH	1
17	SELF TAPPING SCREW WITH PAD ST4.2X16	5	49	SCREW	1
18	LEFT COVER	1	50	CABLE PRESSURE PLATE	3
19	LEFT WEARING PLATE	1	51	TERMINAL BLOCK	3
20	SNOW BUCKET	1	52	TORSION SPRING	3
21	SNOW SHOVELING PLATE	1	53	LABEL	1
22	SELF TAPPING SCREW ST2.9X8	2	54	POWER CABLE	1
23	LED LAMP	2	55	6001-Z BEARING	1
24	RIGHT WEARING PLATE	1	56	SELF TAPPING SCREW ST2.9X9.5	2
25	SMALL COVER	1	57	LARGE WASHER	2
26	SELF TAPPING SCREW ST4.2X16	2	58	SMALL BELT WHEEL AXLE	1
27	LAMP CUP	2	59	SMALL GEAR	1
28	LAMPSHADE	2	60	SUNK SCREW M4XB	2
29	RIGHT COVER	1	61	PAN HEAD SCREW M4XB	2
30	SELF TAPPING SCREW WITH PAD ST4.2X16	5	62	TERMINAL BLOCK	1
31	MB NUT	1	63	SELF TAPPING SCREW ST4.8X16	4
32	TENSION SPRING	1	64	GEARBOX SUPPORT	1

NO.	NAME	QTY	NO.	NAME	QTY
65	MOTOR (15A)	1	99	SWING HANDLE CAP	1
66	SELF TAPPING SCREW ST4.2X19	2	100	SWING HANDLE	1
67	STRAP	1	101	CIRCLIP	1
68	SELF TAPPING SCREW ST4.2X19	3	102	SWING POLE	2
69	WATERPROOF COVER	1	106	MIDDLE POLE	1
70	SELF TAPPING SCREW ST4.2X16	4	107	SELF TAPPING SCREW ST2.9X8	2
71	CIRCLIP	2	108	STEERING SHRAPNEL	1
72	WHEEL	2	109	SELF TAPPING SCREW ST4.2X16	2
73	AXLE	1	110	SWING GEAR SUPPORT	1
74	BOLT M6X35	2	111	LOCK RING	1
75	LARGE WASHER	2	112	COTTER PIN	2
76	M6 NUT	2	113	SWING GEAR	1
77	SELF TAPPING SCREW ST4.8X35	4	114	M6 NUT	1
78	M6 NUT	4	115	LARGE WASHER	1
79	ROLLER BRACKET	2	116	CUP HEAD SQUARE NECK BOLT M6X18	1
80	CURVED WASHER	2	117	DISCHARGE CHUTE COVER	1
81	BOLT M6X35	4	118	CUP HEAD SQUARE NECK BOLT M6X30	1
82	LOWER HANDLE	1	119	KNOB	1
83	CUP HEAD SQUARE NECK BOLT M8X45	4	120	SEAL RING	1
84	KNOB	4	121	DISCHARGE CHUTE	1
85	MIDDLE HANDLE	1	122	SELF TAPPING SCREW WITH PAD ST4.2X16	12
86	SHOVEL CLAMP	2	123	SHELL	1
87	SHOVEL	1	124	WATERPROOF SWITCH	1
88	SELF TAPPING SCREW ST4.2X16	1	125	HANDLE	1
89	UPPER SEAT	1	126	SELF TAPPING SCREW ST4.2X16	2
90	LOWER SEAT	1	127	BIG RUBBER RING	1
91	SPRING	2	128	SPONGE PLATE	4
92	SWITCH BUTTON	1	129	SELF TAPPING SCREW ST4.2X13	8
93	SELF TAPPING SCREW ST4.2X13	3	130	SNOW BUCKET COVER	1
94	UPPER HANDLE	1	131	SELF TAPPING SCREW ST4.8X16	6
95	SWITCH BOX COMPOUND	1	132	DUST PROOF SPONGE	4
96	CORD HOOK	1			
97	WIRE CLIP	3			
98	RUBBER RING	1			

## **WARRANTY**

### **BENCHMARK 22" ELECTRIC SNOW BLOWER WARRANTY**

If this Benchmark tool fails due to a defect in material or workmanship within five years from the date of purchase, return it to any Home Hardware store with the original bill of sale for exchange. This warranty does not include expendable parts including but not limited to blades, brushes, belts, light bulbs and/or batteries.

This warranty covers defects in material or workmanship only. It does not cover normal wear and tear, failure due to abuse/misuse, or defects caused by careless or accidental mishandling. If this Benchmark product is used for commercial or rental purposes, this warranty does not apply.

# 22" ELECTRIC SNOW BLOWER



5 Year Limited Warranty

**BENCHMARK™**  
MC

**BENCHMARK TOOLS CANADA**  
ST. JACOBS, ONTARIO N0B 2N0  
© 2021 Home Hardware Stores Limited

**CUSTOMER SERVICE/TECH SUPPORT**  
1-833-818-4111

**5554-513**

Made in China



\* This Benchmark™ product carries a five (5) year LIMITED warranty against defects in workmanship and materials. See Owner's Manual for full details.



**READ ALL INSTRUCTIONS BEFORE FIRST USE.  
KEEP THIS MANUAL FOR FUTURE REFERENCE.  
KEEP AWAY FROM CHILDREN.**



**WEAR CSA APPROVED  
EYE PROTECTION**



**WEAR EAR  
PROTECTION**



**WEAR A  
FACE MASK**