

5554-051

BENCHMARK™

28" 302cc TWO-STAGE GAS POWERED SNOW BLOWER WITH ELECTRIC START, LED LIGHTS AND POWER STEERING





This product is supported by **Midland Power**. Contact us directly for assistance and warranty help. Do not return this product to store.

You must register online for your warranty to be valid. It only takes a minute, do it now while you still have your purchase receipt.

Register Your Product Online

[www.benchmark.midlandpowerinc.com/
register-warranty](http://www.benchmark.midlandpowerinc.com/register-warranty)



Support for your product is available online, including parts, service center locations, and live expert advice.

Visit us online at

www.benchmark.midlandpowerinc.com



Or call us anytime at **1-877-528-3772**.

Thanks for choosing Benchmark!

You're excited to get started, we'll keep this brief.

READ THIS ENTIRE GUIDE BEFORE USING THIS PRODUCT AND SAVE FOR LATER USE.

This user guide contains important instructions including safety, setup, operation, and maintenance that must be followed. All information in this guide is based on information available at the time of print. This guide or revised editions can be found on our website for download. No part of this publication may be reproduced without written permission.

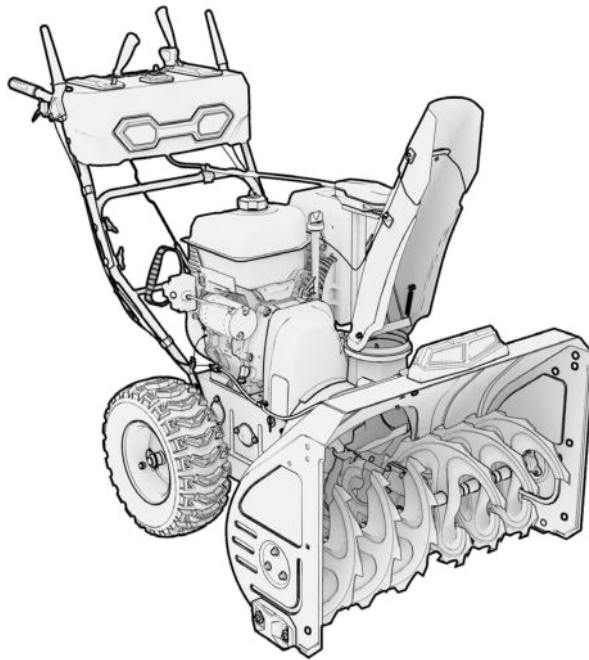

THIS PRODUCT MEETS ALL CERTIFICATION REQUIREMENTS FROM:



The engine exhaust from this product contains chemicals known to cause cancer, birth defects or other reproductive harm.

©2025 Benchmark. All Rights Reserved.

5554-051_Manual_EN_2025-05-12

TABLE OF CONTENTS

1. Safety	1
2. Learn About Your Snowblower	4
3. Assembly instructions	9
4. Pre-Operation Check	26
5. Starting the Engine	30
6. Stopping the Engine	35
7. Using your snowblower	36
8. Maintenance	44
9. Transportation & Storage	60
10. Troubleshooting	62
11. Technical Specifications	66
12. Appendix	67
13. Limited Warranty	68

1. SAFETY

⚠ WARNING!

U.S.A. Models: It is a violation of California Public Resource Code Section 4442 to use or operate the engine on any forest-covered, brush-covered, or grass-covered land unless the exhaust system is equipped with a spark arrester, as defined in Section 4442, maintained in effective working order. Other states or federal jurisdictions may have similar laws. Contact the original equipment manufacturer, retailer, or dealer to obtain a spark arrester designed for the exhaust system installed on this engine.

1.1 SNOWBLOWER SAFETY

The snowblower is designed and intended only for clearing of snow from hard-surface ground-level walkways and driveways and is not intended for any other purpose.

Only allow operators who are responsible, trained, familiar with these instructions, and physically capable operate the machine. If it is misused or not properly maintained, it can be dangerous. Remember you are responsible for your safety and those around you.

This snowblower is capable of amputating hands and feet, and throwing objects. Hand contact with the rotating impeller inside the discharge chute is the most common cause of injury associated with snowblowers.

- This machine is capable of throwing objects that could injure bystanders or cause damage to buildings.
- When leaving the operating position always disengage the auger, turn off the engine, and remove the key. Never leave a running machine unattended.
- Never operate the snowblower without proper guards, and other safety protective devices in place and working.
- Be careful when operating on or crossing gravel drives, walks, or roads. Stay alert for hidden hazards or traffic.
- Never operate the snowblower without good visibility or light. Always be sure of your footing, and keep a firm hold on the handles. Walk; never run.
- Be careful to avoid slipping or falling, especially when operating the snowblower in reverse.
- Be careful when operating on slopes.
- After striking a foreign object, stop the engine, remove the wire from the

spark plug, thoroughly inspect the snowblower for any damage, and repair the damage before restarting and operating the snowblower.

- Do not operate the equipment without wearing adequate winter garments. Avoid loose fitting clothing that can get caught in moving parts. Wear footwear that will improve footing on slippery surfaces.
- Never touch a hot muffler or engine. Allow muffler and engine cylinder to cool before touching.

1.2 ENGINE SAFETY

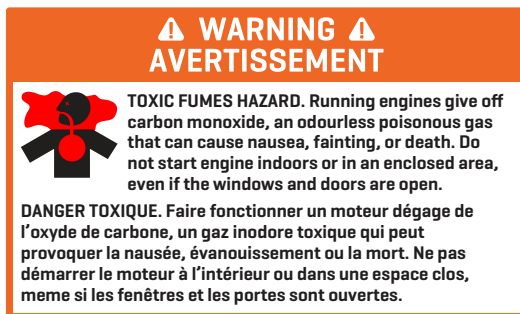

⚠ WARNING!

- Always perform an oil and fuel check before starting the engine.
- Properly clean and maintain the equipment.
- Before operating, read the user guide carefully. Otherwise, personal injuries or equipment damage may result.
- Pay attention to the warning labels. The engine exhaust system will become heated during operation and remain hot immediately after the engine is stopped.
- Gasoline is a highly flammable and explosive liquid. Refuel in a well ventilated area with the engine stopped.
- Use of gasoline with an ethanol content greater than 10% can damage the engine and fuel system and will void the manufacturer's warranty.
- When refueling, keep it away from cigarettes, open flames, smoke and/or sparks.
- Do not touch the spark plug while the engine is operating or shortly after the engine has been shut down.
- Know how to stop the engine quickly and understand operation of all the controls. Never permit anyone to operate the engine without proper instructions.
- Do not operate in rain or snow.

- To avoid breathing in poisonous carbon monoxide from the exhaust gases, adequate ventilation should be provided if running in a partially enclosed space.
- If stored outdoors, check all electrical components before each use. Moisture can damage the electronics and can lead to an electric shock.
- Do not connect an extension to the exhaust pipe.
- If you start to feel sick, dizzy, or weak after the engine has been running, move to fresh air RIGHT AWAY. See a doctor. You could have carbon monoxide poisoning.

1.3 AC SAFETY

⚠ WARNING!

Before connecting the snowblower to an electrical device or power cord:

- Make sure that everything is in proper working order. Faulty devices or power cords can lead to an electrical shock.
- Turn off immediately if the device begins to operate abnormally. Then disconnect and investigate the problem.
- Use only a three-conductor power cord properly grounded to the power source.
- Use a tough rubber sheathed flexible cable (according to IEC245 or equivalent standards). The maximum length of the extension cable: 196 feet (60 meters) for cable of 15.5 gauge (1.5mm²); 328 feet (100 meters) for cable of 13.25 gauge (2.5mm²).

1.4 MAINTENANCE SAFETY

⚠ WARNING!

- After any maintenance is performed, wash immediately using soap and clean water because repeated exposure to lubricant may cause skin irritation.
- Allow the engine to cool down and turn off the engine before performing any maintenance. Failure to do so can cause severe personal injury or death.
- Do not clean with a pressure washer.
- Use rubber gloves when coming into contact with engine oil.
- Always stop the engine before removing the oil filler cap.
- Only qualified maintenance personnel with knowledge of fuels, electricity, and machinery hazards should perform maintenance procedures.

2. LEARN ABOUT YOUR SNOWBLOWER

This section will show you how to identify key parts of your snowblower. Going over the terminology below will make sure we're on the same page.

2.1 COMPONENT IDENTIFICATION

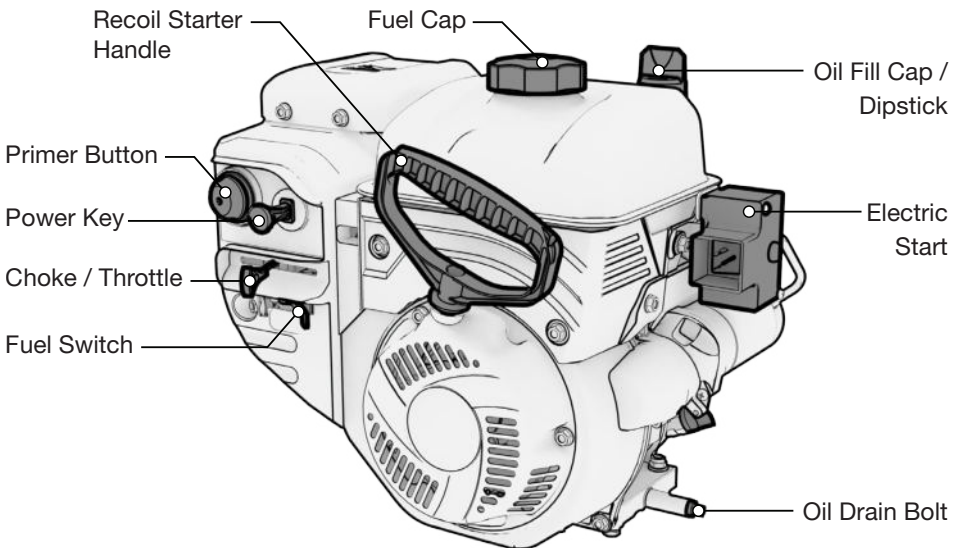
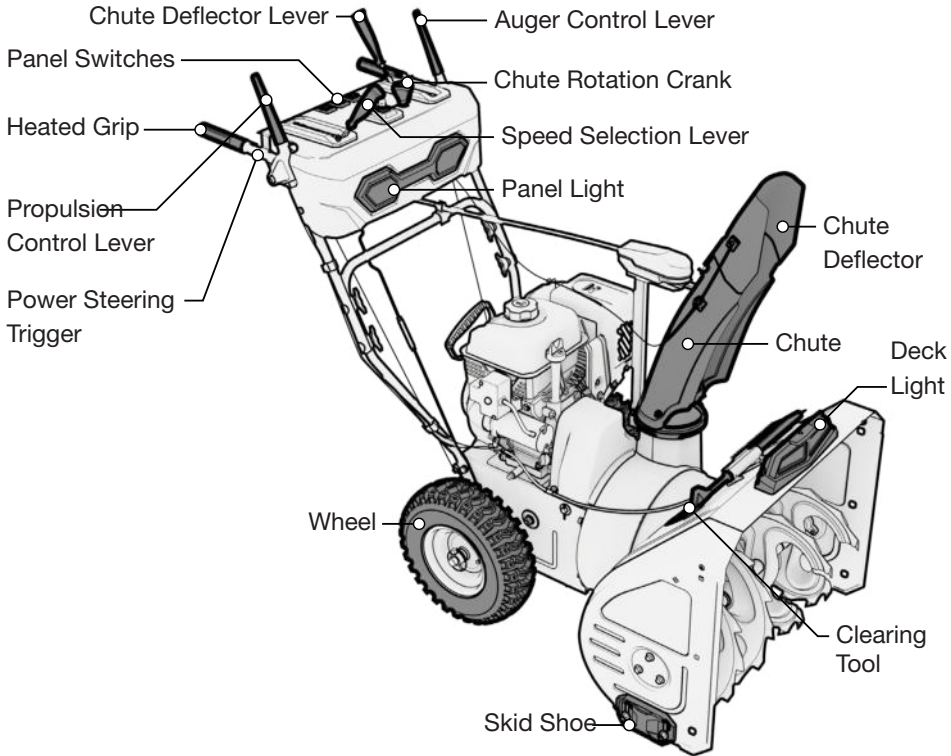

2.2 CONTROL FUNCTIONS

Auger Control Lever

- Engages the augers and impeller.

Clean Out Tool

- Tool used for unclogging the impeller and/or chute. NEVER clean a clogged impeller or chute with your hands.

Electric Start Module

- Connect a 15A extension cord from a wall receptacle to this module to enable electric starting.

Primer Button

- Primes the carburetor with additional fuel for easier cold starting.

Propulsion Control Lever

- Engages the self-propelled wheels to run at the speed set by the speed selector lever.
- One-handed control lock feature: The one-handed control lock feature on the snowblower allows users to control and maneuver the machine using only one hand while leaving the other hand free. This feature activates when both control levers are pressed down and it automatically disengages when the Propulsion lever is released. The Auger Control Lever can be released if the Propulsion lever is engaged. Releasing the Propulsion lever will disengage the Auger Control lever as well.

Power Steering Trigger

- Pull the left and right triggers to turn the unit while being propelled.

Auger Height Adjust Lever

- Adjusts the height of the auger, allowing for easier transport or deeper removal of snow,

Choke/Throttle Lever

- Combines two controls into one simple lever. The choke restricts the airflow into the carburetor, causing a higher fuel-to-air ratio in the mixture entering the engine. This enriched mixture helps the engine start and run smoothly when it is cold. Throttle controls the RPM of the engine.

Fuel Switch

- When off, stops fuel flow from gas tank to carburetor.

Recoil Starter Handle

- Used to start engine manually.

Speed Selector Lever

- Used to select the speed and direction of the propulsion system

Chute Rotation Crank

- Rotates the chute (Changing the throwing angle).

Chute Deflector Lever

- Changes the throwing distance.

2.3 MAKE SURE YOU HAVE EVERYTHING

Make sure your snowblower has everything listed in the table below.

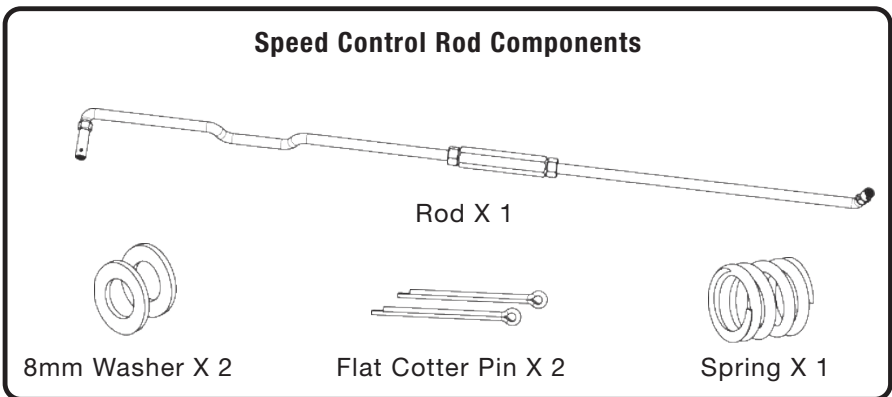
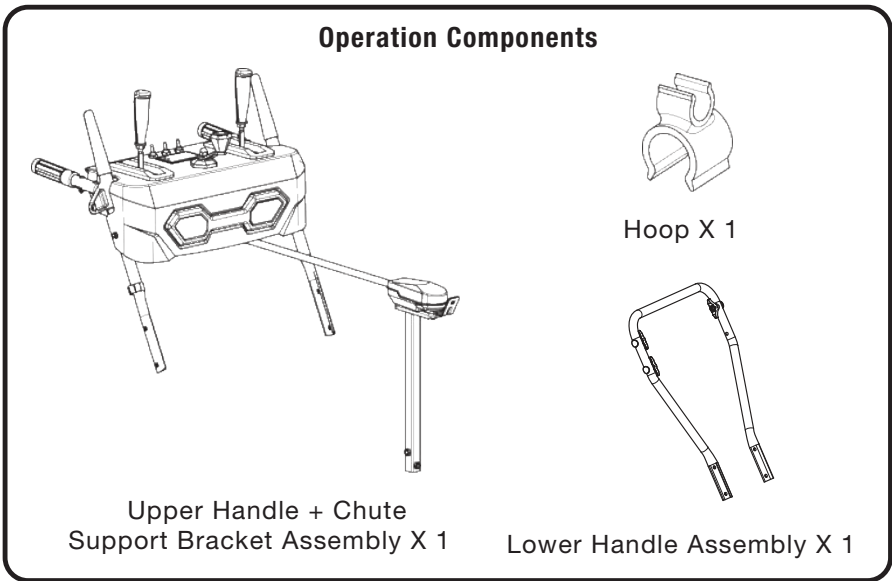
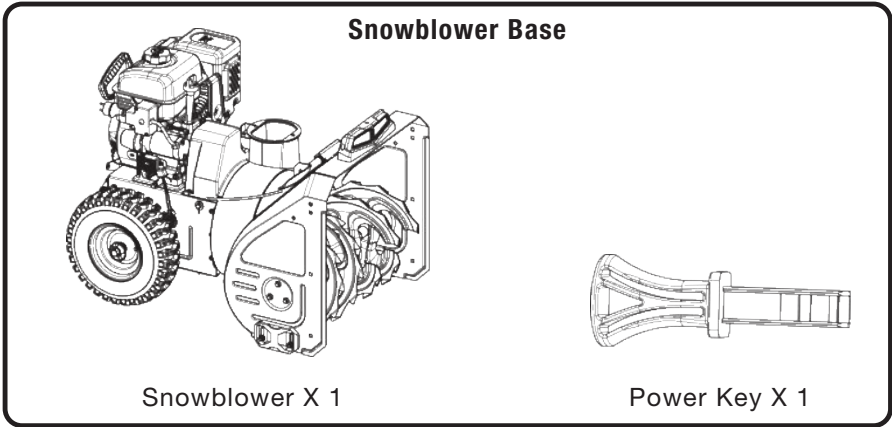

Chute Components

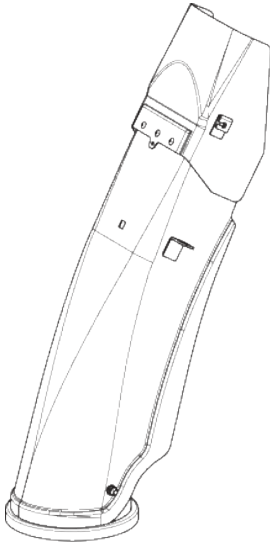

Chute Assembly X 1



Deflector Spring X 1



M8 Locking Nut X 1

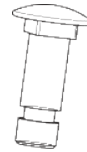

M8x25 Bolt X 1

Spare Parts

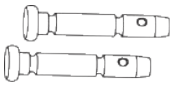

Shear Pin X 2

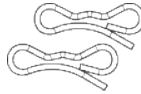

Bowtie Clip X 2



Flat Cotter Pin X 2

Others



Spark Plug Wrench X 1



Spark Plug
Wrench Handle X 1



Oil Bottle X 1

3. ASSEMBLY INSTRUCTIONS

3.1 INSTALLING THE HANDLE

Installing the Lower Handle

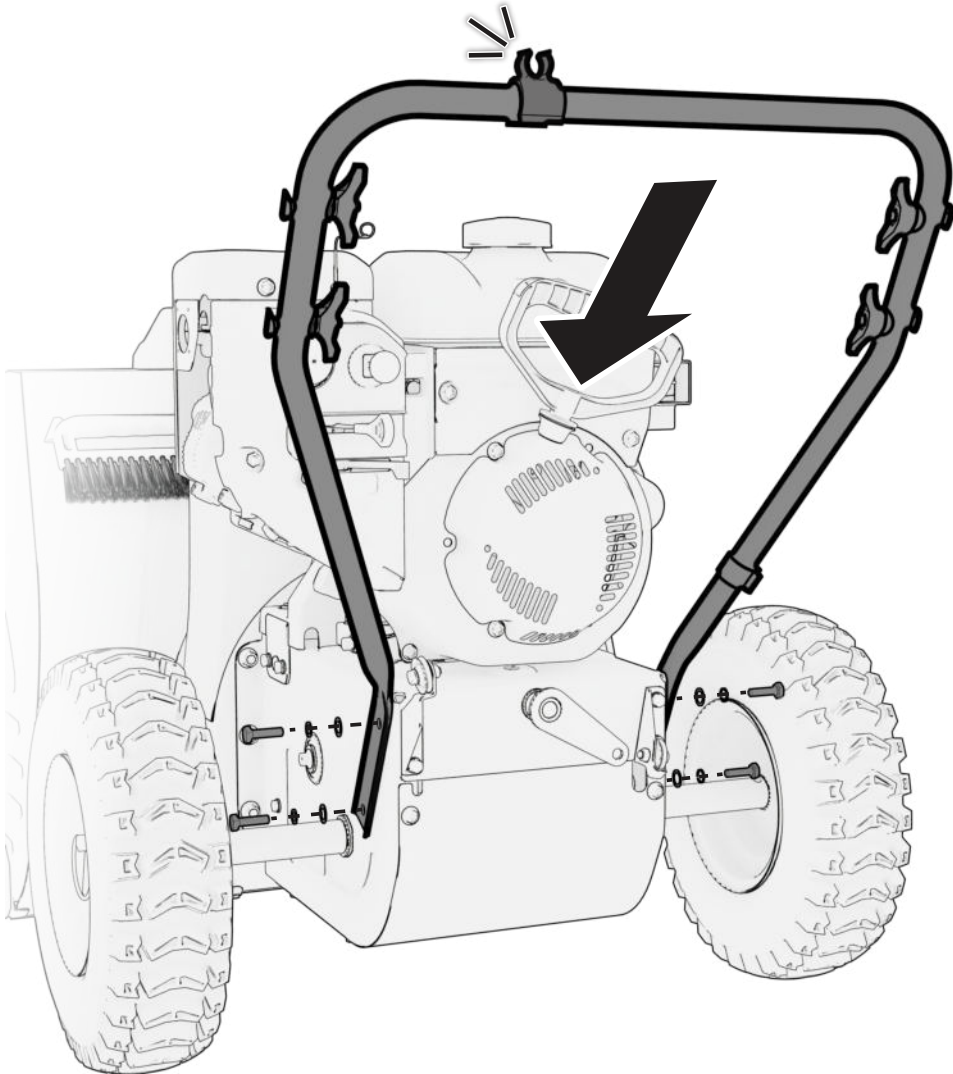

1. Remove the four M8x25 flange bolts, spring washers and flat washers on the sides of the chassis.
2. Align the lower handle assembly with the four holes on the chassis as shown in the diagram. Reinstall the four flat washers, spring washers, M8x25 flange bolts and tighten.
3. Install the Hook for the Chute Rotation Cable.

Installing the Upper Handle

NOTE

- To install the upper handle onto the lower handle, you will need to use the pre-installed knobs on the lower handle.

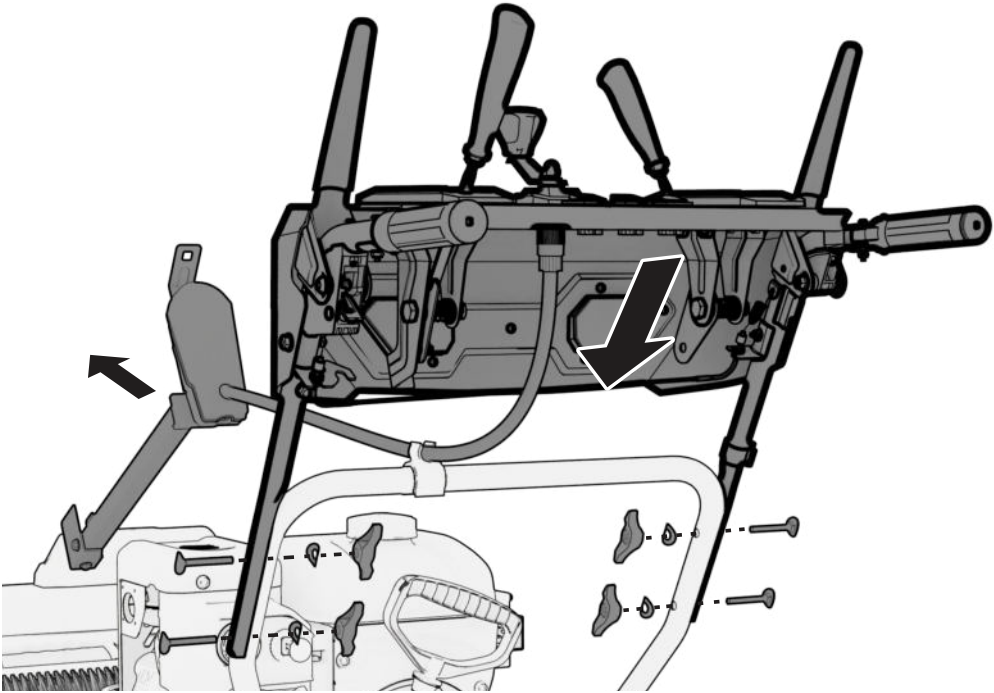

1. Remove the four knobs, curved washer, and M8x50 carriage bolts on the lower handle.
2. Install the upper handle assembly on to the lower handle assembly and align the 4 holes.
3. Reinstall the four M8x50 carriage bolts, curved washer, knobs and tighten.
4. Move the chute support bracket through the upper and lower handles. Attach the chute rotation cable to the hook.

3.2 INSTALLING THE AUGER AND PROPULSION CONTROL CABLE

Auger Control Cable

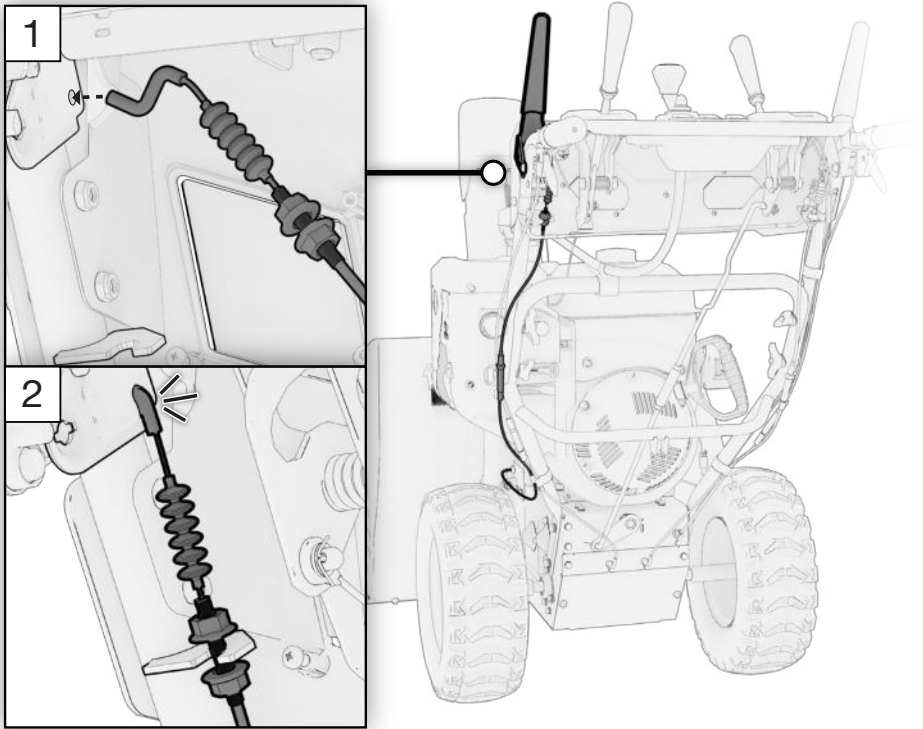

1. Install the hook end of the cable into the the Auger Control Lever hole.
2. Place the cable tension nuts into the slot below the handle.

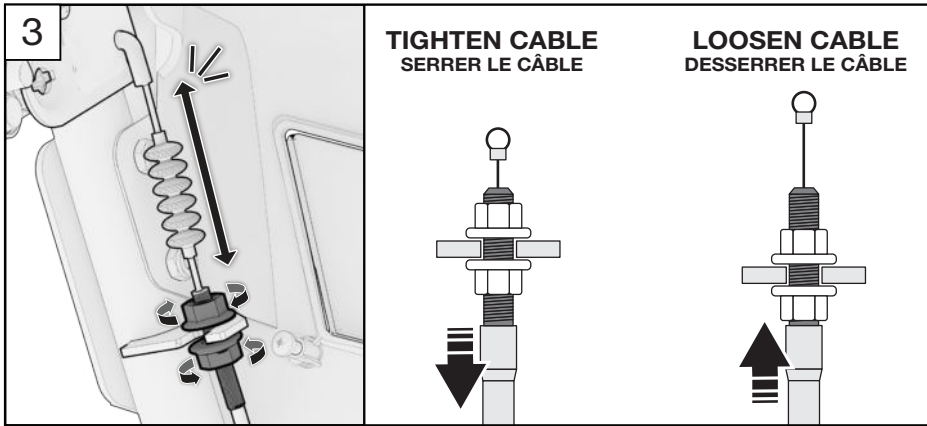

3. Tighten the cable tension nuts.

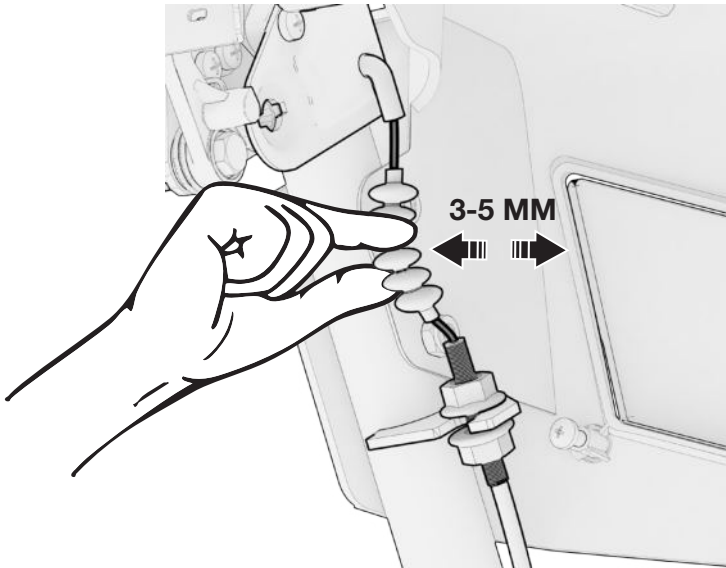

4. The cable should not be tight when the lever is resting. When the lever is pressed, the cable should become tight within the first 3-5mm of travel. To set the correct tension, loosen the nut and reposition the cable housing. Once correct tension is set, re-tighten the nut.

Propulsion Control Cable

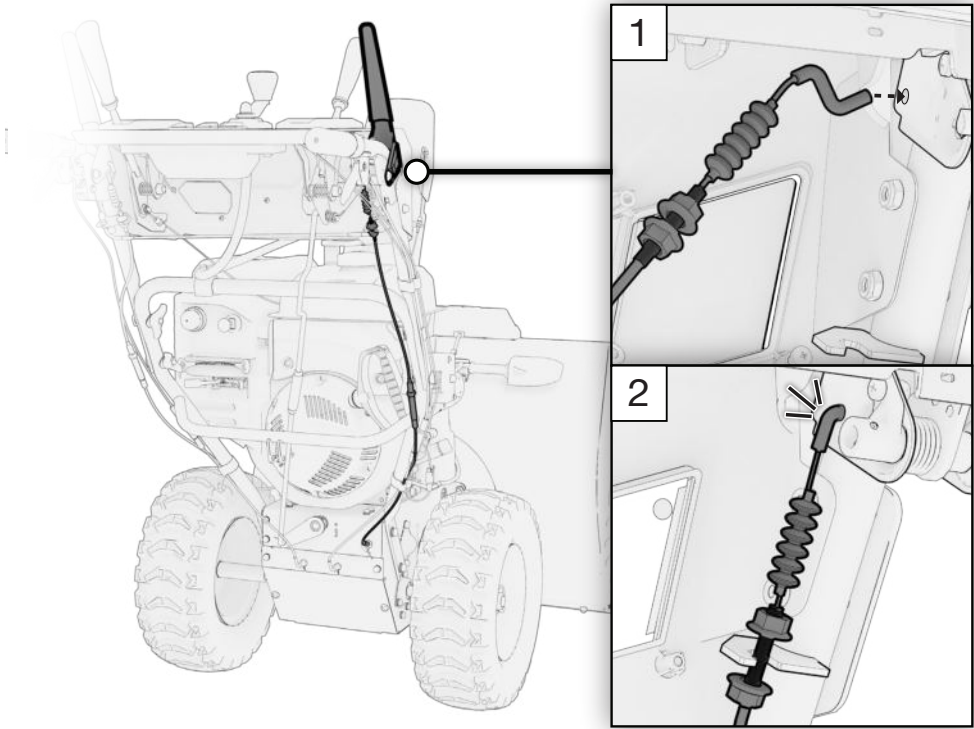

1. Install the hook end of the cable into the the Propulsion Control Lever hole.
2. Place the cable tension nuts into the slot below the handle.

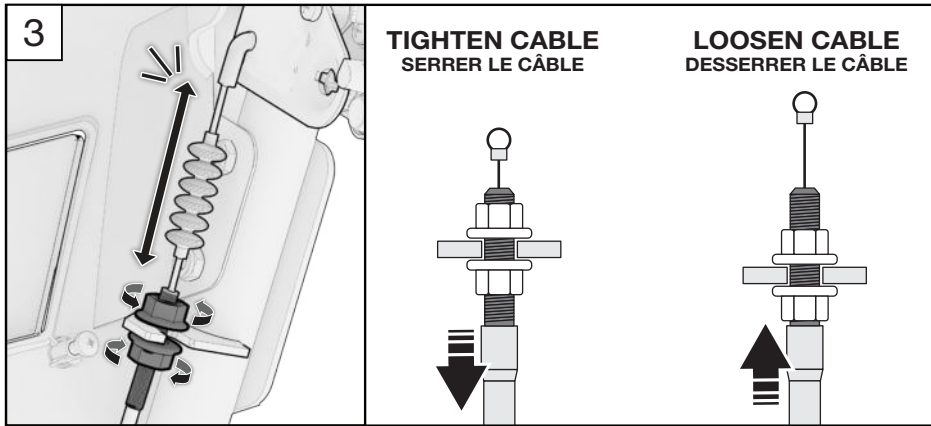

3. Tighten the cable tension nuts.

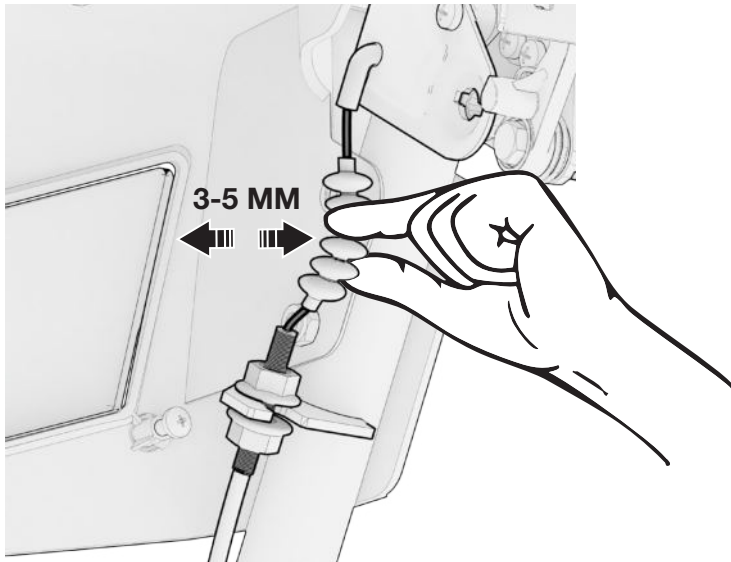

4. The cable should not be tight when the lever is resting. When the lever is pressed, the cable should become tight within the first 3-5mm of travel. To set the correct tension, loosen the nut and reposition the cable housing. Once correct tension is set, re-tighten the nut.

3.3 INSTALLING THE POWER STEERING CONTROL CABLE

Left Power Steering Cable

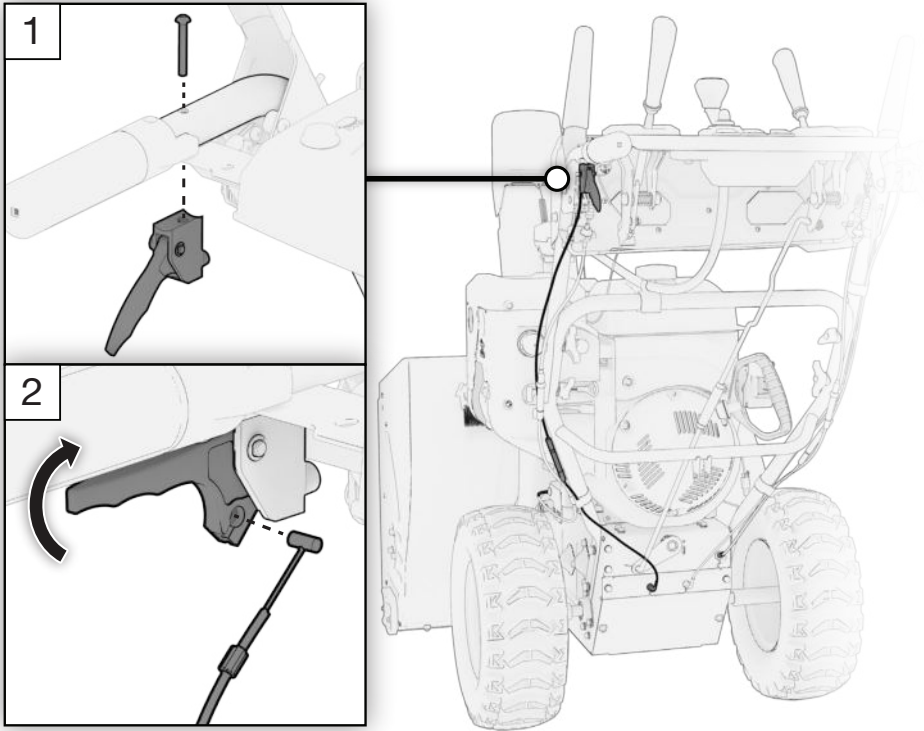

1. Fasten Power Steering Trigger Assembly to handle with screw.
2. Pull the trigger inward. Install the cable end into the trigger slot.

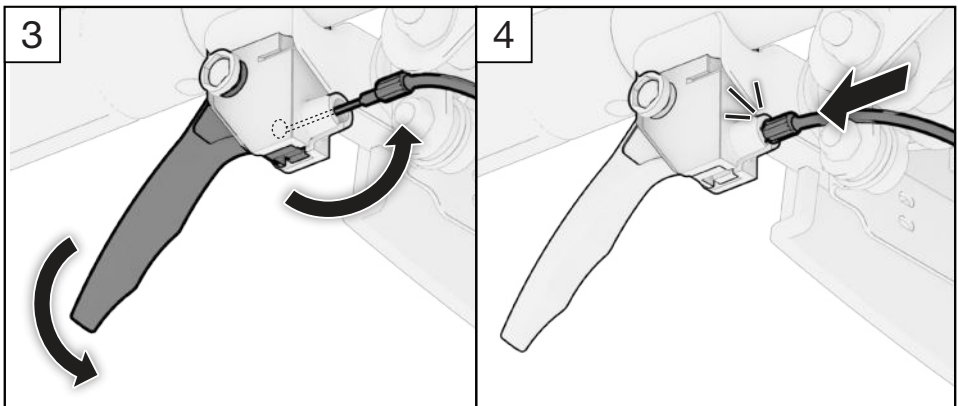

3. Rotate the cable into the trigger's housing. Release the trigger.
4. Pull the cable forward and insert the cable housing end into the trigger perch as shown.

Right Power Steering Cable

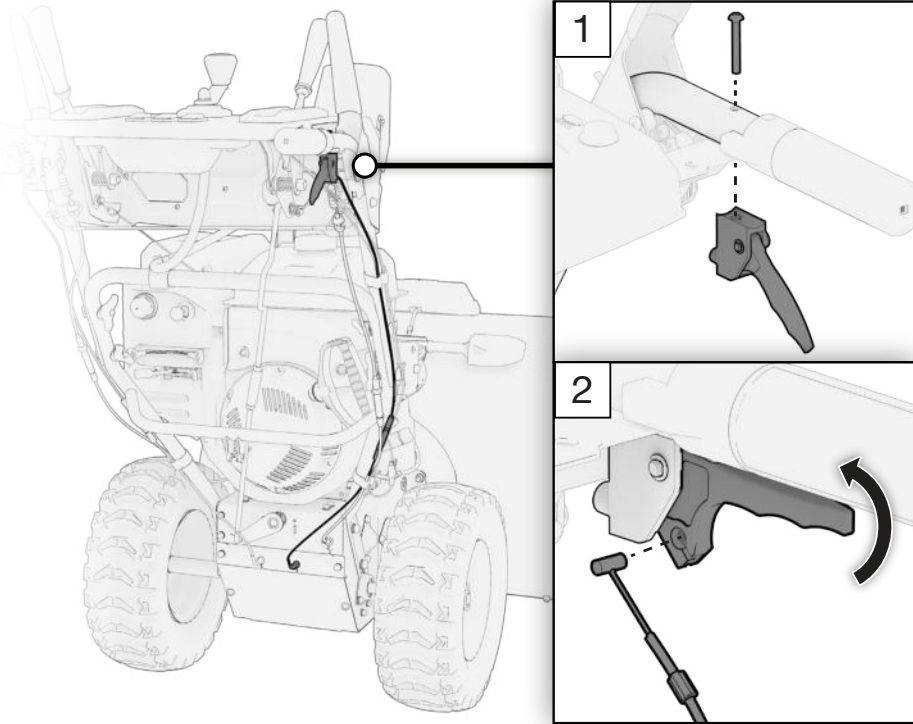

1. Fasten Power Steering Trigger Assembly to handle with screw.
2. Pull the trigger inward. Install the cable end into the trigger slot.

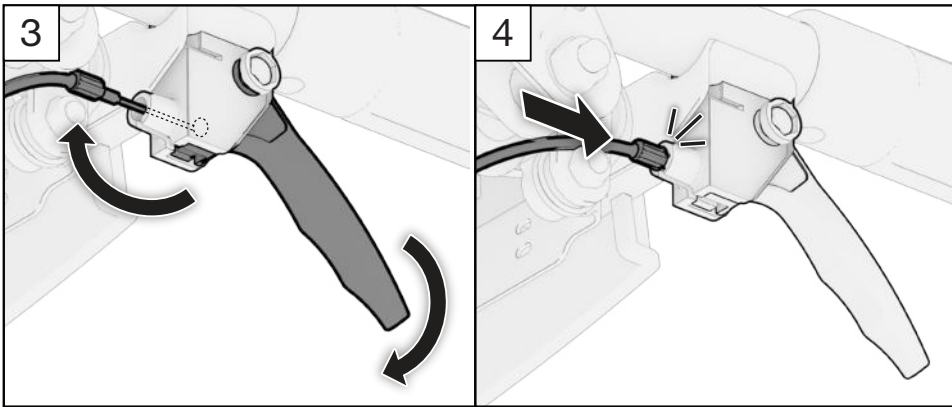

3. Rotate the cable into the trigger's housing. Release the trigger.
4. Pull the cable forward and insert the cable housing end into the trigger perch as shown.

3.4 INSTALLING THE SPEED SELECTION ROD

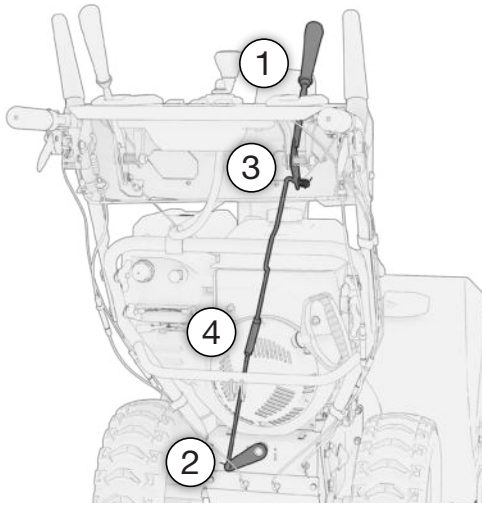

In order to install the Speed Selection Rod, follow the numbered instructions.

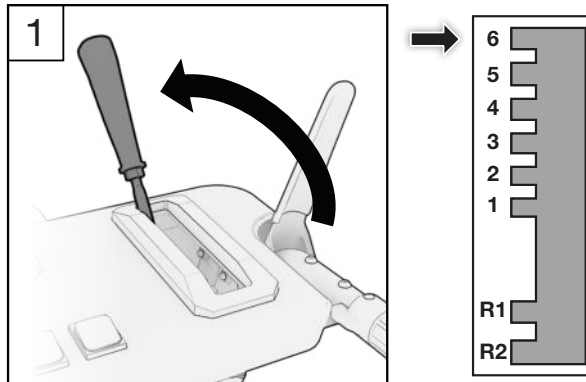

1. Set the Speed Selection Lever to Position 6.

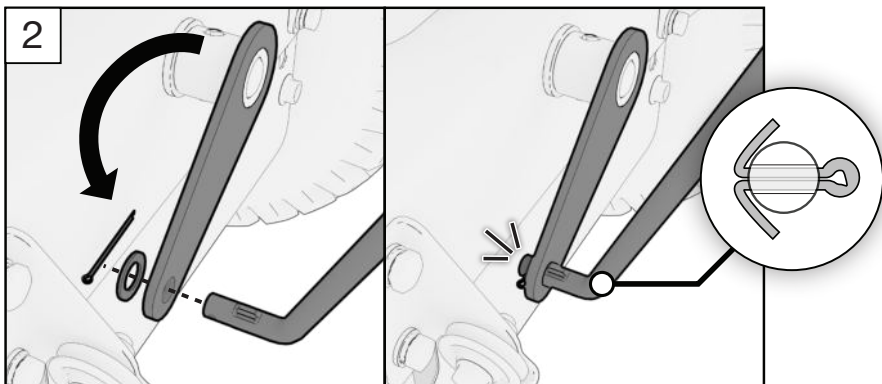

2. Install the short bent end of the speed selection rod to the gearbox. Attach it with one flat spacer and one cotter pin.



3. Install the long bent end of the speed selection rod to the control panel. Attach it with one spring, one flat spacer and one cotter pin.

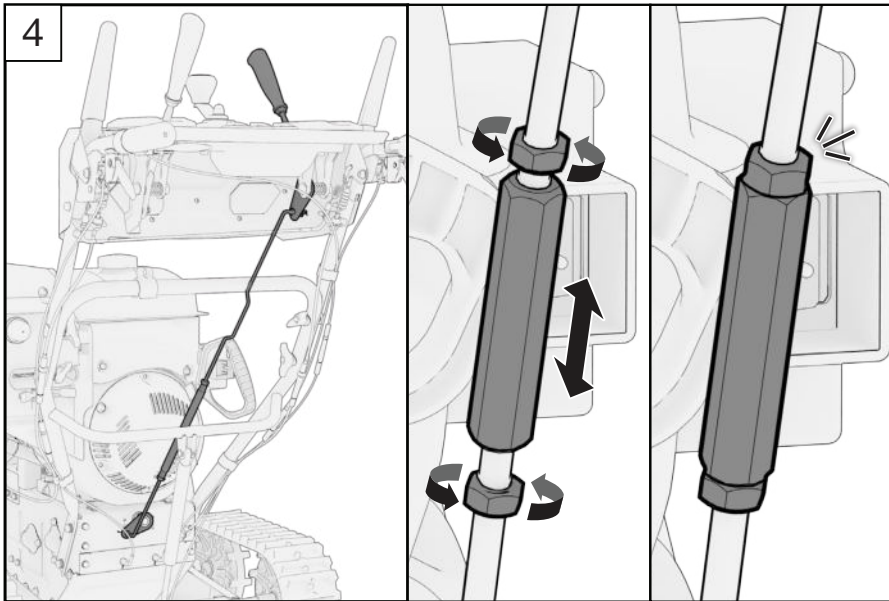

4. Ensure the Speed Selection Lever, when set to Position 6, is the lowest position on the gearbox. If necessary, adjust speed selection rod's length by loosening, adjusting, and tightening the center nuts.

3.5 INSTALLING THE CHUTE

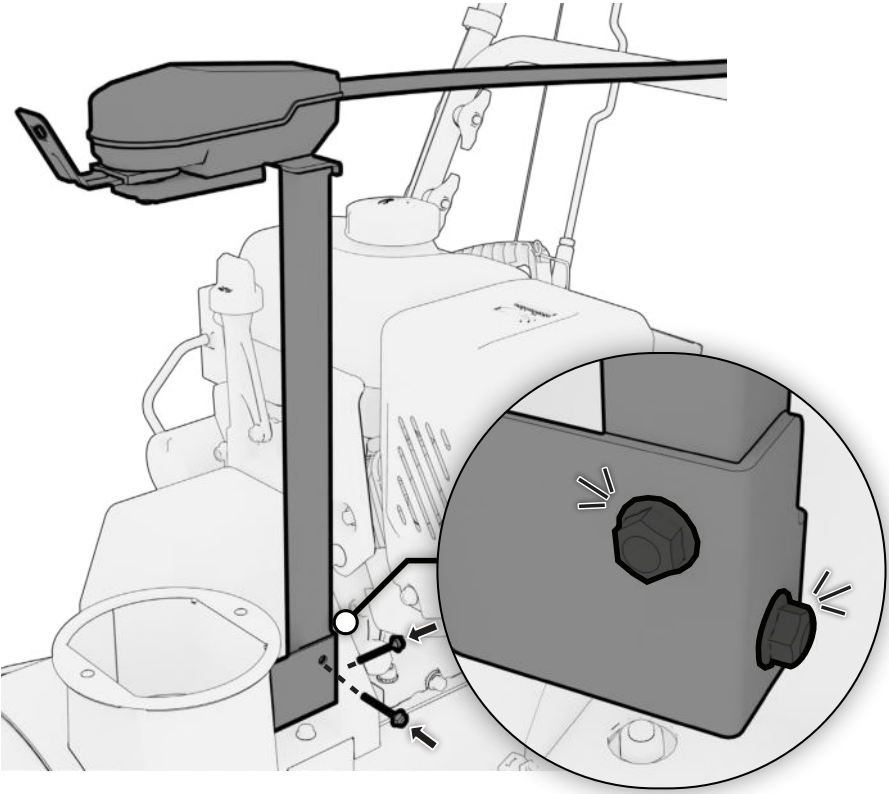

1. Remove the two M8×16 flange bolts from the chute support bracket.
2. Install the chute support on to the chute support bracket.
3. Reinstall and tighten the two M8×16 flange bolts.

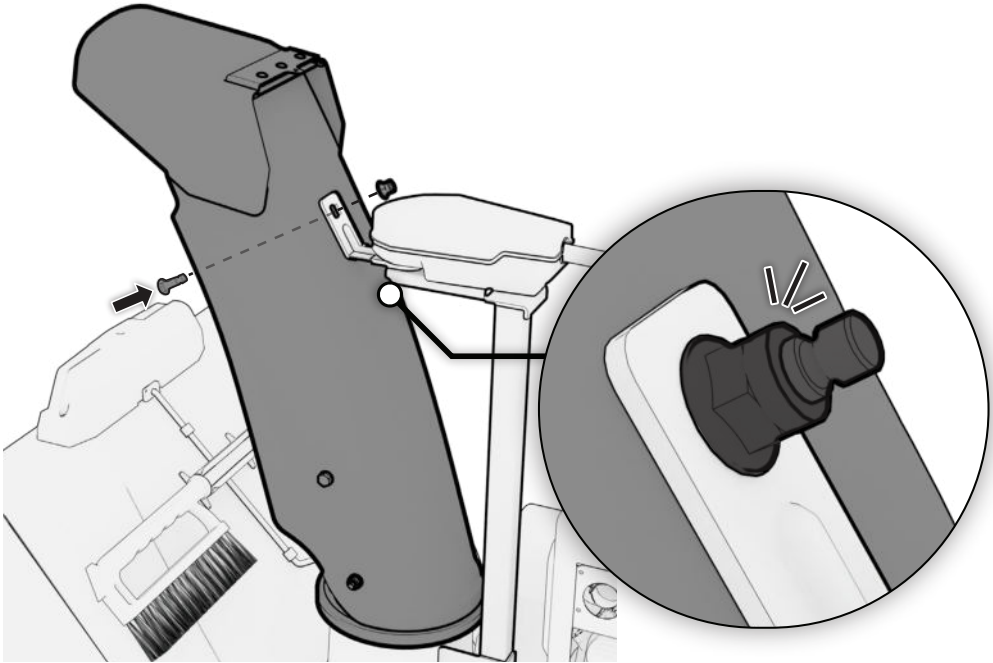

4. Install the chute assembly onto plastic collar and chute support tab. Install and tighten the M8×25 flange bolt using the M8 Lock Nut.

3.6 INSTALLING THE CHUTE DEFLECTOR CABLE AND SPRING

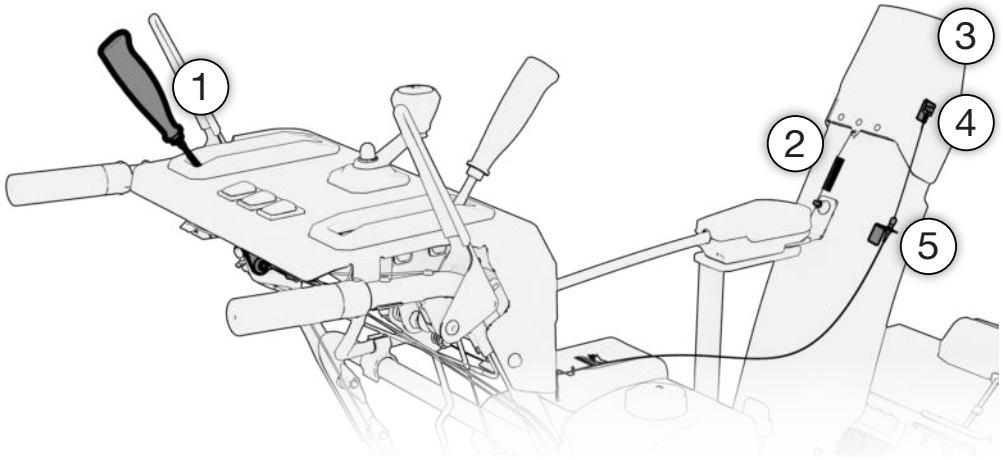

In order to install the Chute Deflector Cable, follow the numbered instructions.

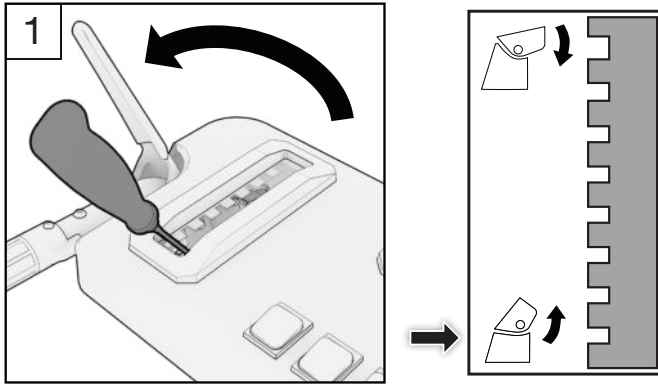

1. Pull the Chute Deflector Lever back to it's farthest position, towards the heated grips.

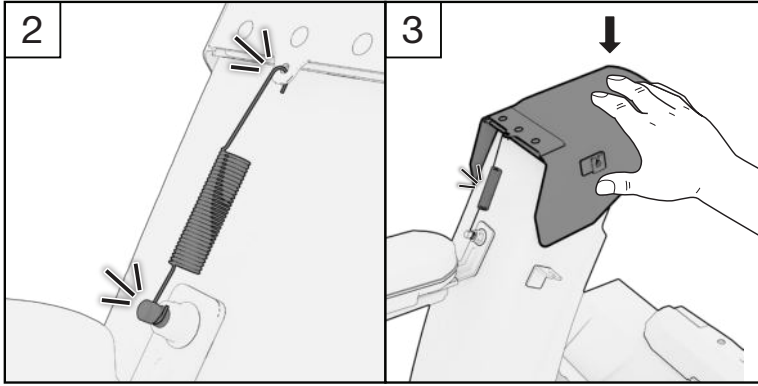

2. Hook the **short** end of the spring to the lower chute bracket. Hook the **long** end of the spring to the upper chute bracket.
3. Push the chute deflector down. Keep the chute deflector held down to install the chute deflector cable.

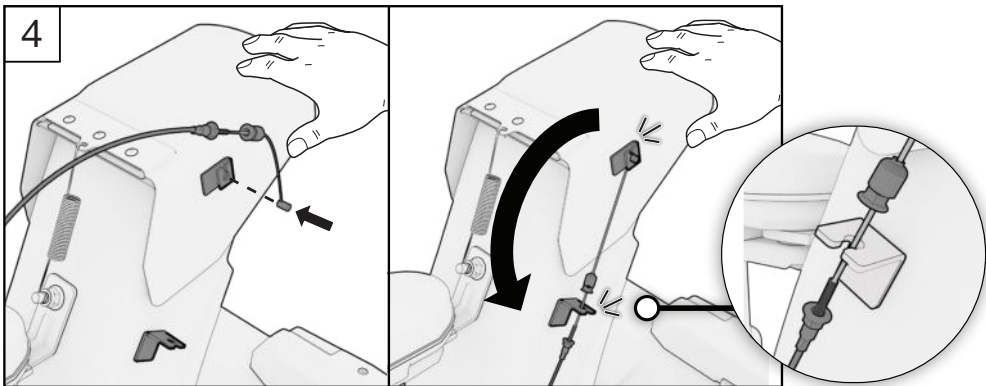

4. While holding the chute deflector down, loop the chute deflector cable into the tab on the side on the chute deflector, and into the tab on the chute.

NOTE

- Undo the top nut on the chute deflector cable to allow the cable to pass through the tab on the chute.

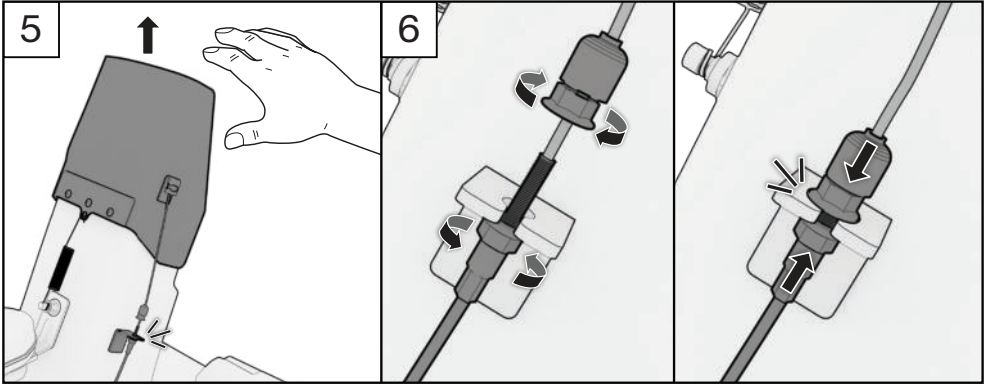

TIGHTEN CABLE
SERRER LE CÂBLE

LOOSEN CABLE
DESSERRER LE CÂBLE

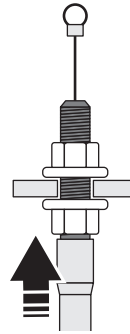
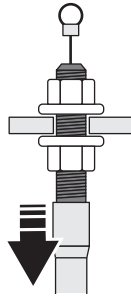

5. Slowly let go of the chute deflector. Ensure the chute deflector cable is straight and tight.
6. Tighten the chute deflector cable's nuts. Ensure the chute deflector cable is still straight and tight.

NOTE

- When the chute deflector lever is set all the way backward, The deflector should be pointing fully upward. To set the correct tension, loosen the two nuts and reposition the cable housing end. once correct tension is set, re-tighten the two nuts.

3.7 ASSEMBLE THE SKID SHOES

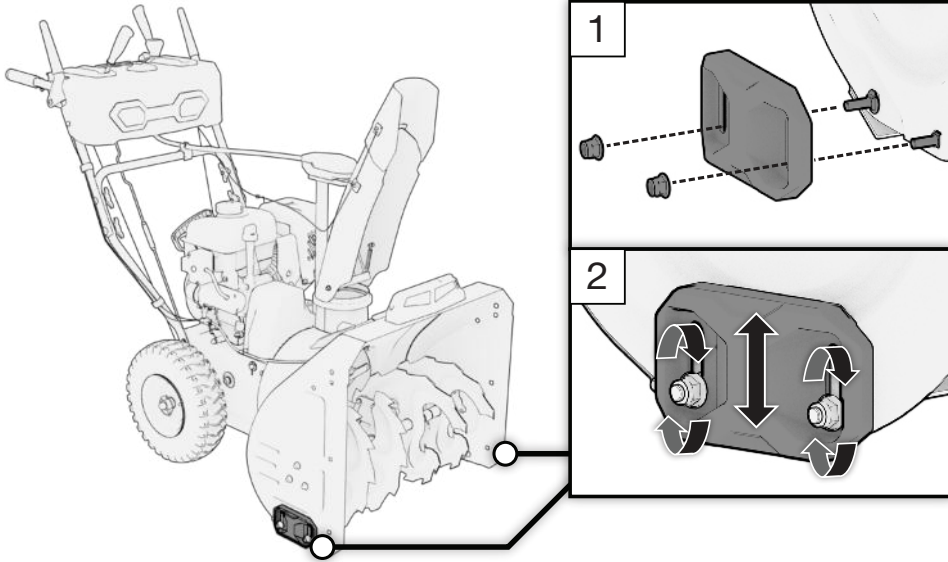

1. Remove the M8x25 bolts and nuts. Re-install with skid shoes.
2. Adjust height of skid shoes, and re-tighten bolts.

3.8 ASSEMBLE THE HARNESS CABLE AND CABLE CLIPS

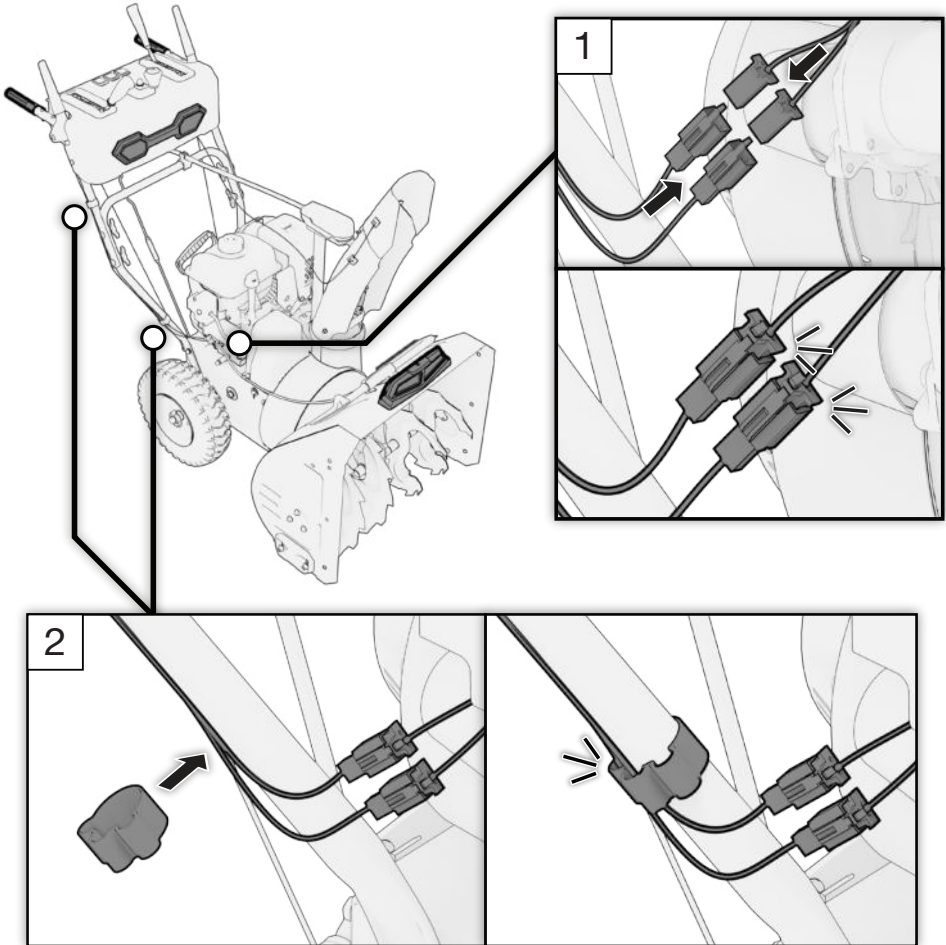

1. Connect the wiring harness connectors to the engine's auxiliary power connectors.
2. Connect the cable clips to the side of the upper and lower handles.

4. PRE-OPERATION CHECK

The engine was shipped from the factory without oil. Before you start the engine, ensure that you add oil according to the instructions in this manual. If you start the engine without oil, it will be damaged beyond repair and will not be covered under the warranty.

4.1 ADD OIL

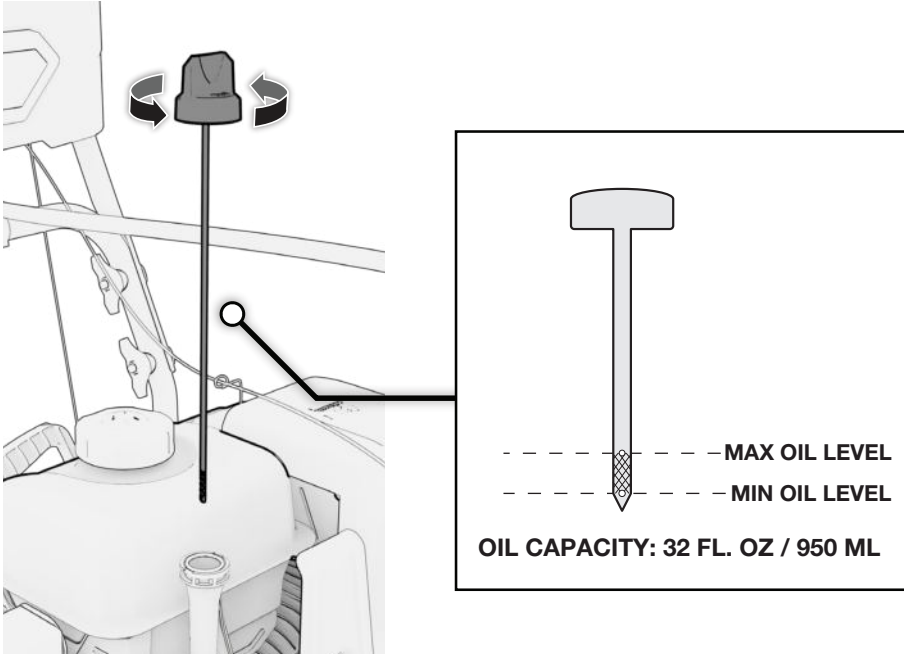

1. Set the snowblower on a level surface and the power switch to OFF.
2. Clean the oil fill area of any moisture or debris.
3. Unscrew the oil dipstick and wipe it off.
4. Remove the dipstick and fill the oil to the maximum oil mark. Check the oil level by reinserting the dipstick *without* rethreading it.
5. Reinsert the dipstick and tighten securely.

NOTE

- Oil max. capacity: 32 fl. Oz / 950 mL
- SAE 5W-30 is recommended for general use.
- Use of synthetic oil does not change maintenance intervals.
- DO NOT OVERFILL.

EFFECTIVE VISCOCITY RANGE OF ENGINE OILS

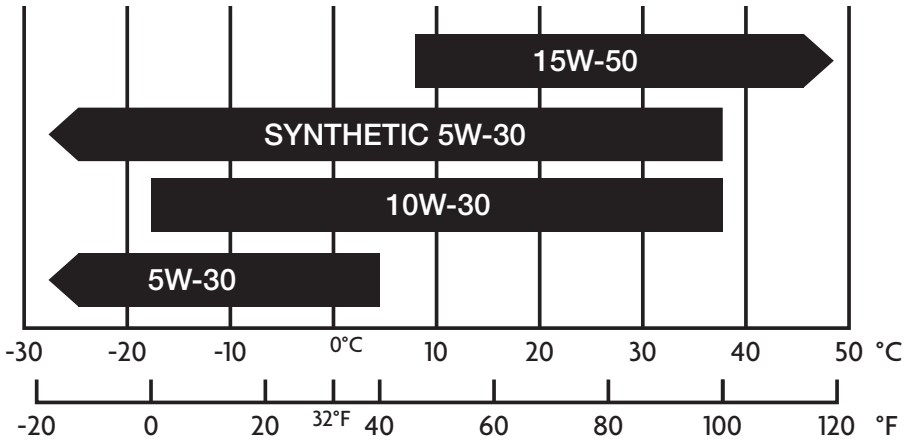

- Do not tilt when adding engine oil. This could result in overfilling and damage to the engine.
- Use high quality 4-stroke engine oil, certified to meet or exceed API standard SG, SF, SAE ratings with strong detergents. Using non-detergent or 2-stroke oil could shorten the engine's working life.
- Do not mix different engine oils.
- Handle and store the engine oil with care, avoid getting dirt or dust into the engine oil.
- To avoid damaging the engine, check the oil level as often as possible.

4.2 ADD FUEL

⚠ DANGER! ⚠

Gasoline is highly flammable and explosive under certain conditions. Refuel in a well-ventilated area with the engine stopped. Do not smoke or allow open flames or sparks in the area where the engine is being refueled or where gasoline is stored. Do not overfill the tank. Be careful not to spill fuel when refueling. Wipe up any spilled gasoline and let the area dry before starting the engine.

Gasoline substitutes such as gasohol are not recommended. They may be harmful to the fuel system components.

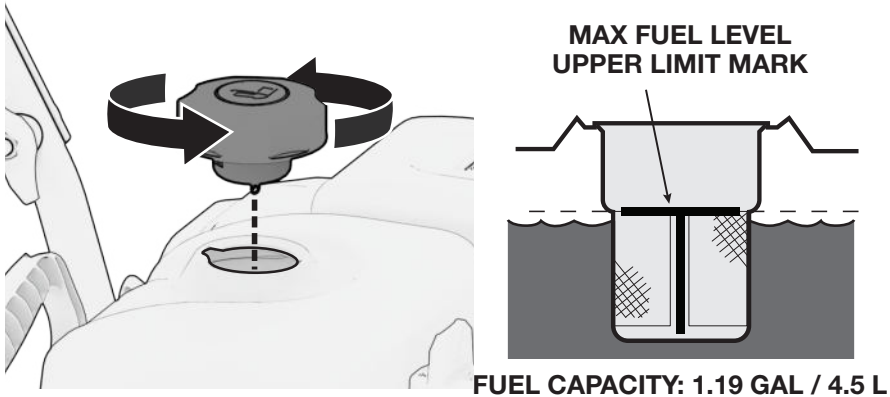

NOTE

- Fuel max. capacity: 1.19 Gal / 4.5 L
- Use of gasoline with an ethanol content greater than 10% can damage the engine and the fuel system and will void the manufacturer's warranty.
- Only use unleaded gasoline (Octane 85 or higher).
- Never use stale or contaminated gasoline, or an oil/gasoline mixture.
- Avoid getting dirt or water into the fuel tank.
- Do not use a mixture of gasoline containing methanol. This will cause serious damage to the engine.

4.3 SURVEY YOUR AREA

1. Familiarize yourself with the area in which you plan to operate the snowblower. Mark off all boundaries of walkways and driveways.
2. Ensure the area to be cleared is free of debris or objects that could be picked up by the auger and thrown from the chute.
3. Ensure the operating area is clear of bystanders, especially children. Be alert and turn the unit off if bystanders enter the area. Use extra care when approaching blind corners, shrubs, trees, or other objects that may obscure vision.

5. STARTING THE ENGINE

DANGER!

Using a gas powered engine indoors **WILL KILL YOU IN MINUTES.**

Engine exhaust contains high levels of carbon monoxide (CO), a poisonous gas you cannot see or smell. If you can smell the engine exhaust you are breathing CO. Even if you cannot smell the exhaust, you could be breathing CO.

NEVER use an engine inside a home, garage, crawlspace, or other partly enclosed area, deadly levels of carbon monoxide can build up in these areas. Using a fan or opening windows and doors will **NOT** supply enough fresh air.

ONLY use a engine outdoors and far away from open windows, doors, and vents. These openings can pull in engine exhaust. Even when you use a engine correctly, CO may leak into the home. **ALWAYS** use a CO alarm in your home.

If you start to feel sick, dizzy, or weak after the engine has been running, move to fresh air **RIGHT AWAY** and seek medical attention. You could have carbon monoxide poisoning. Never run the engine in an enclosed or even partially enclosed area where people may be present.

NOTE

- Do not crank the engine with the spark plug removed.
- Do not over-prime the engine. If the engine floods, set choke (if equipped) to OPEN/RUN position, move throttle (if equipped) to FAST position and crank until engine starts.

5.1 STARTING THE ENGINE

Manual Recoil Start

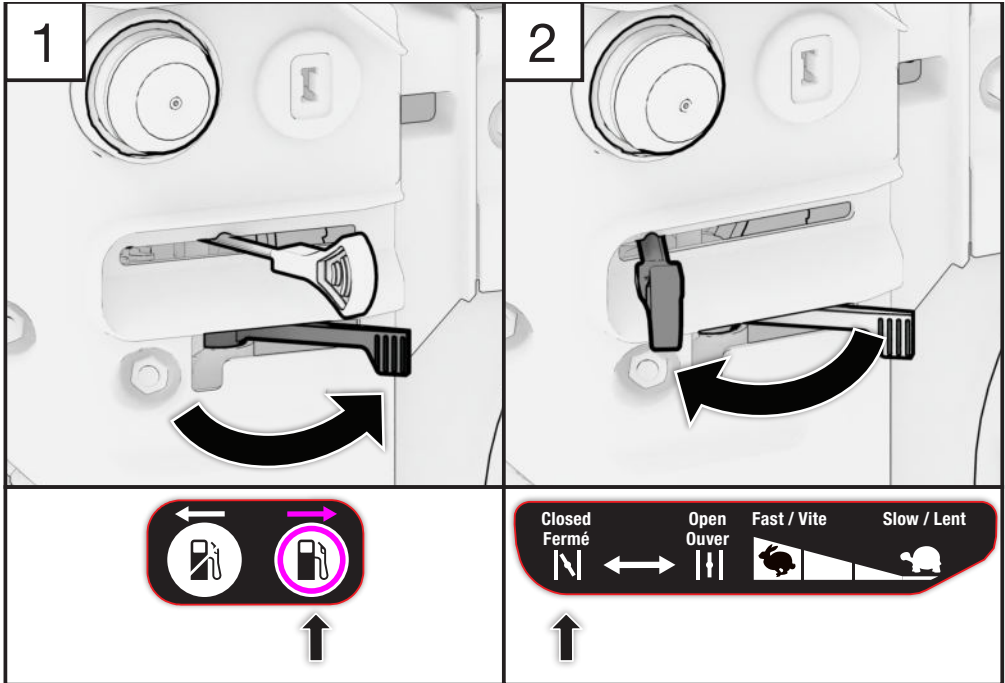

1. Turn the fuel switch to the OPEN position.
2. Turn the choke/throttle to the CLOSED position.

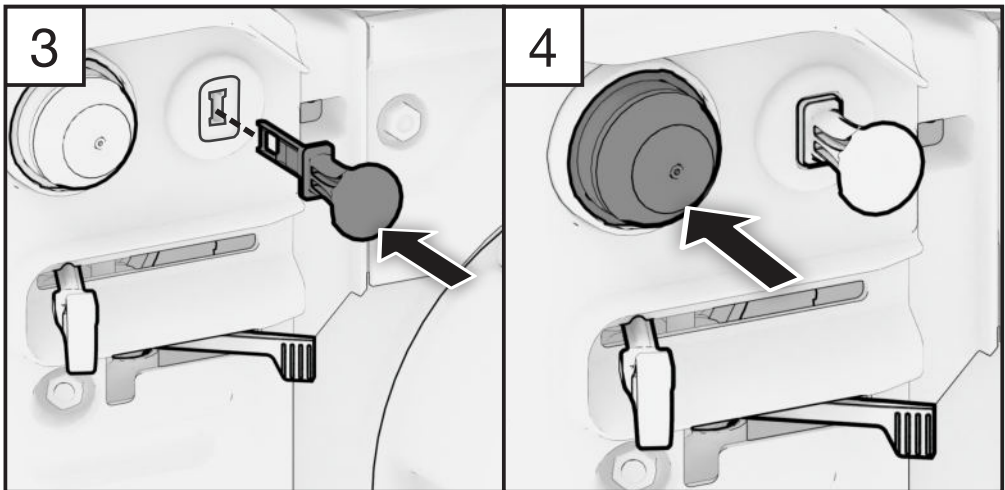

3. Insert the POWER key.
4. If the engine is cold, press the primer button 3 times.

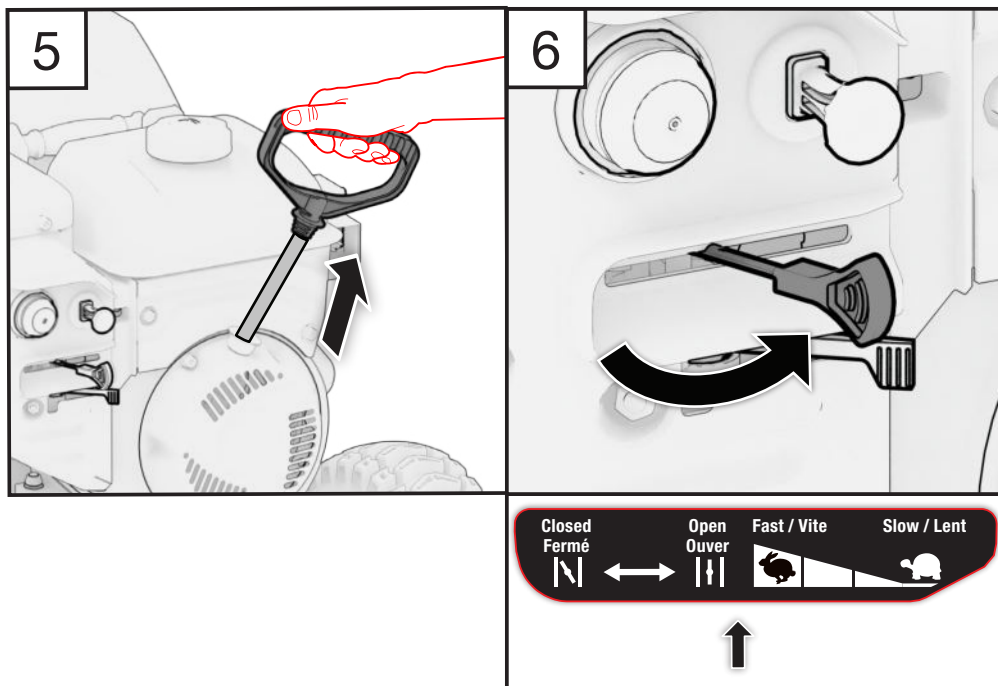

5. Pull the recoil grip slowly until it engages then pull quickly. Repeat until the engine starts.
6. Allow the engine to warm up for several minutes. Gradually move the choke/throttle lever to the OPEN position.

NOTE

- Return the starter grip slowly by hand, do not let it snap back.
- Rapid retraction of the starter cord (kickback) will pull your hand and arm toward the engine faster than you can let go and may cause injury.

Electric Start

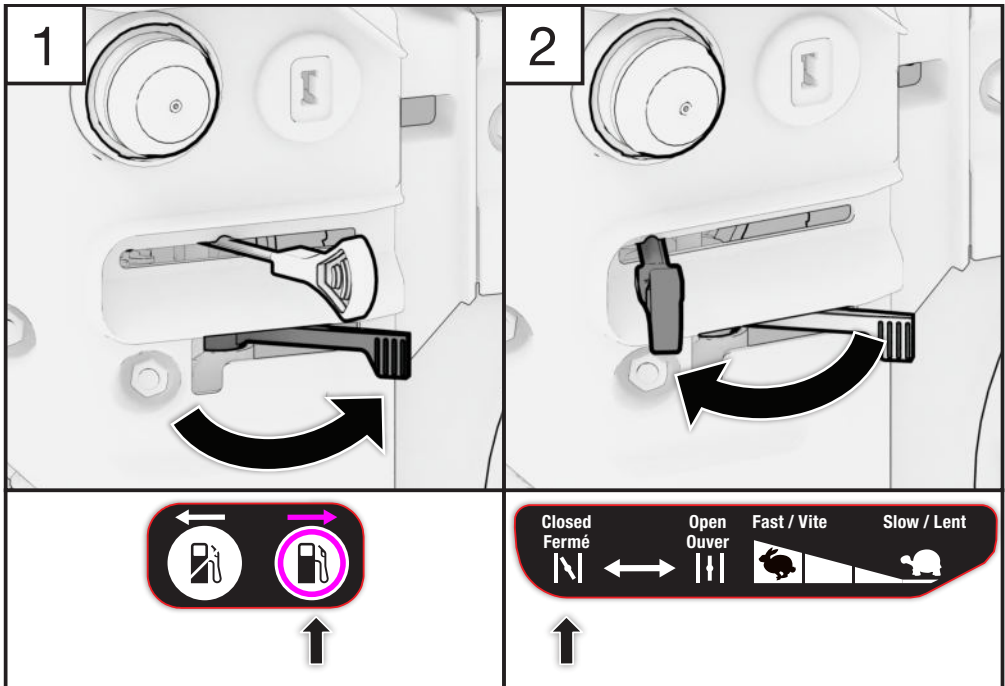

1. Turn the fuel switch to the OPEN position.
2. Turn the choke/throttle to the CLOSED position.

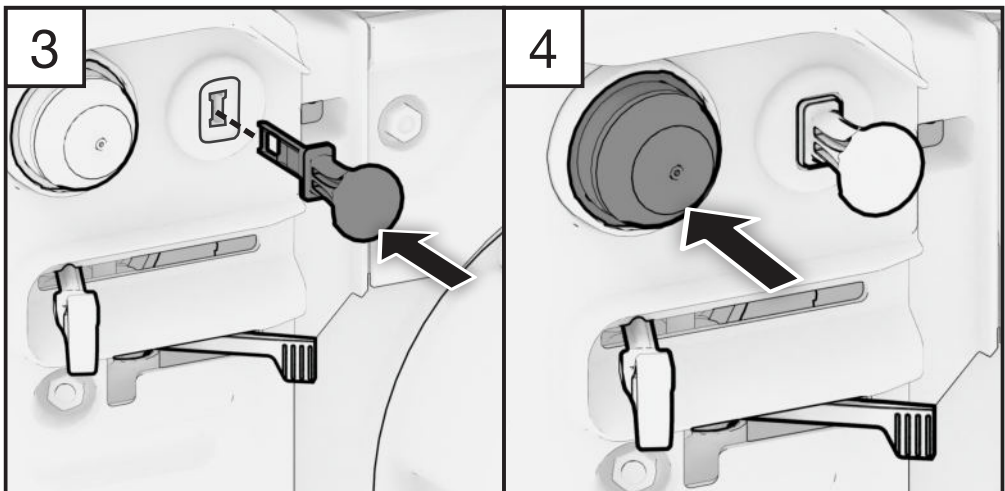

3. Insert the POWER key.
4. If the engine is cold, press the primer button 3 times.

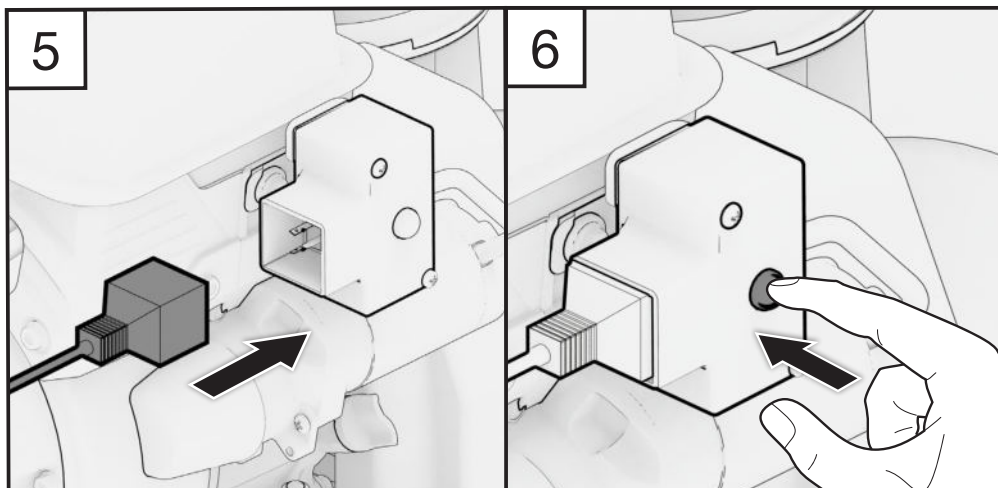

5. Connect an extension cord from a wall receptacle to the electric start module on the engine.
6. Press and hold the START button for no more than 5 seconds then release. If it does not start after 5 attempts, consult the troubleshooting chapter.

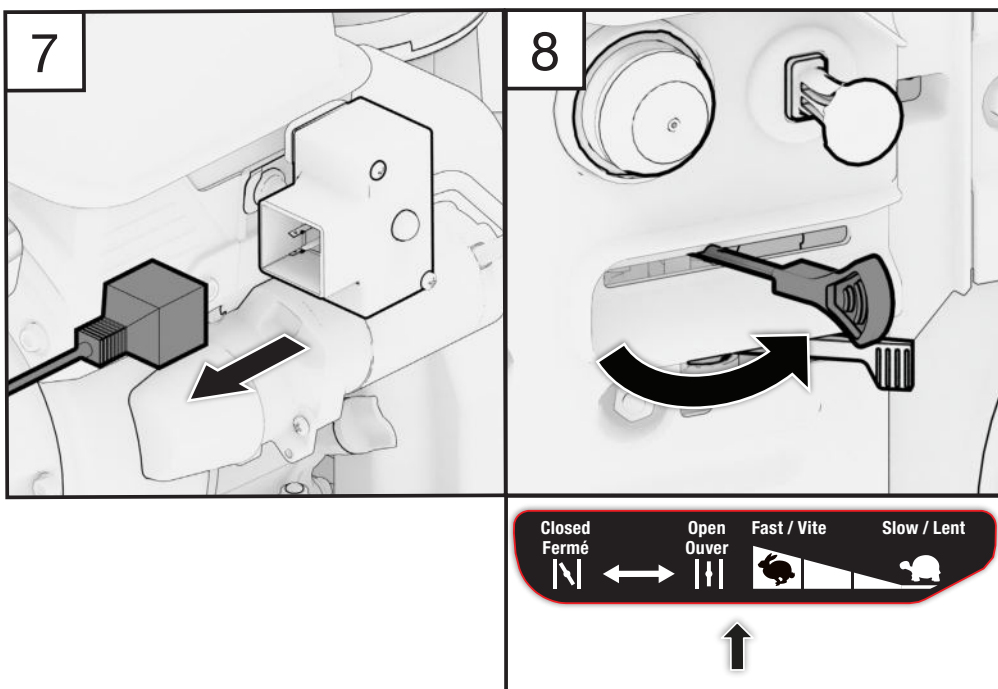

7. Disconnect the extension cord from the wall receptacle and then from the starter box.
 - Allow the engine to warm up for several minutes. Gradually move the choke/throttle lever to the OPEN position.

6. STOPPING THE ENGINE

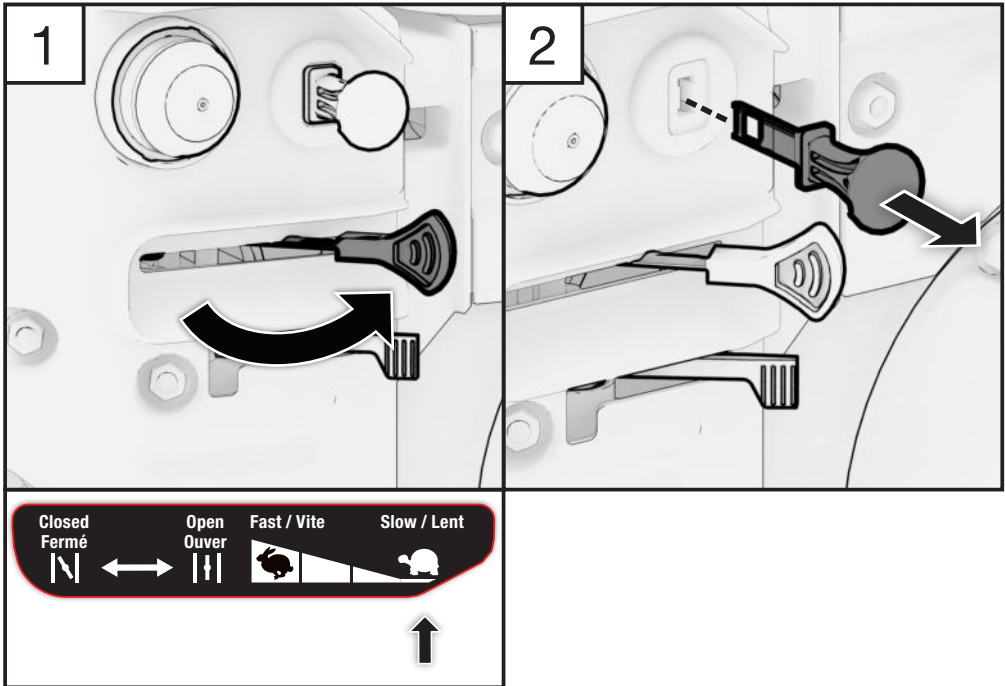

1. Turn the choke/throttle to the SLOW position.
2. Remove the POWER key.

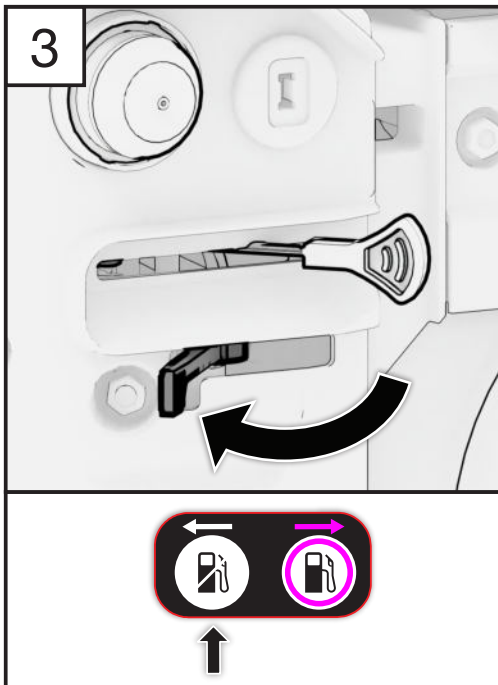

3. Turn the fuel switch to CLOSED and allow engine to cool before storing.

NOTE

- Make sure the fuel valve is in the CLOSED position when stopping, transporting, and storing the engine.

7. USING YOUR SNOWBLOWER

7.1 ADJUSTING THE CHUTE AND CHUTE DEFLECTOR

⚠ WARNING!

Ice, gravel, or other unintended objects can be picked up by the auger and thrown from the chute with force. Objects thrown from the chute could cause death, serious injury, or property damage.

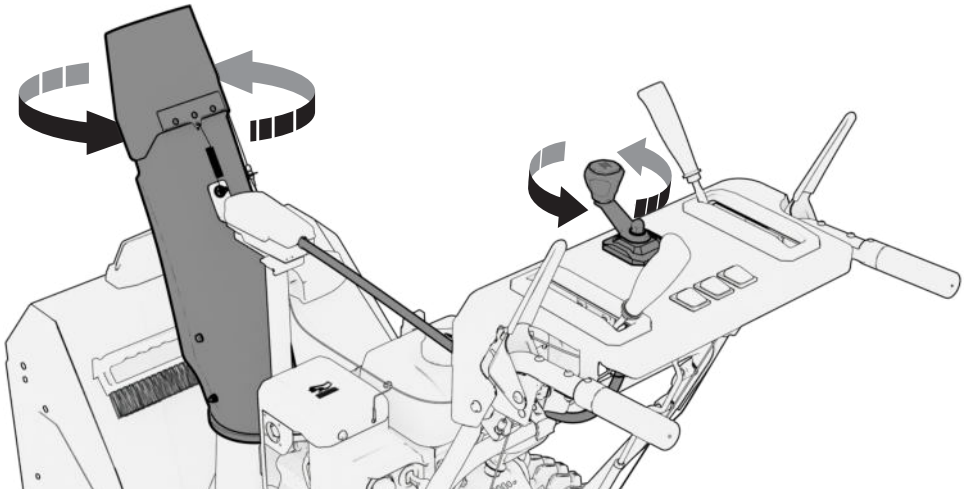

1. Rotate the chute rotation crank to set the direction of the discharge chute.

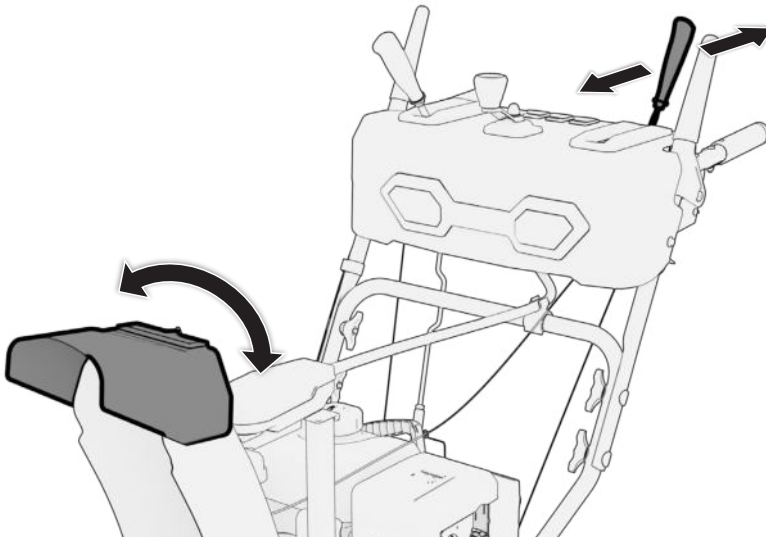

2. Use the chute deflector lever to move the deflector up or down. Raise the chute deflector lever to throw snow further.

7.2 ENGAGING THE AUGER AND IMPELLER

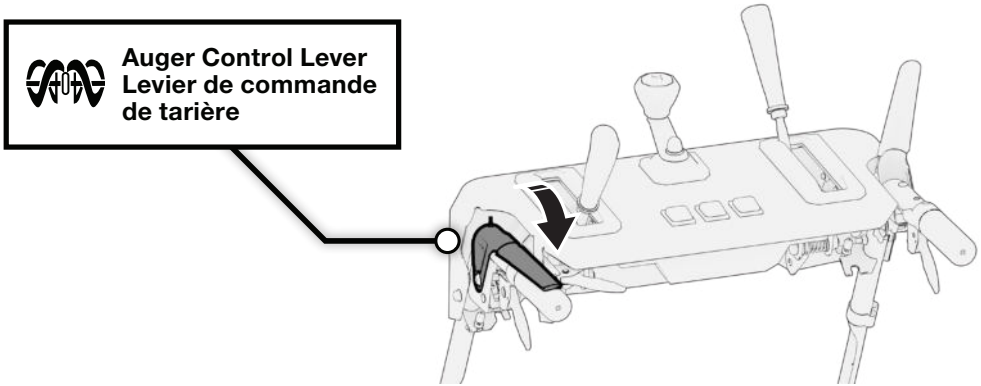

Fully press the auger control lever into the grip of the left handle to engage the auger and impeller.

7.3 ENGAGING THE DRIVE WHEELS

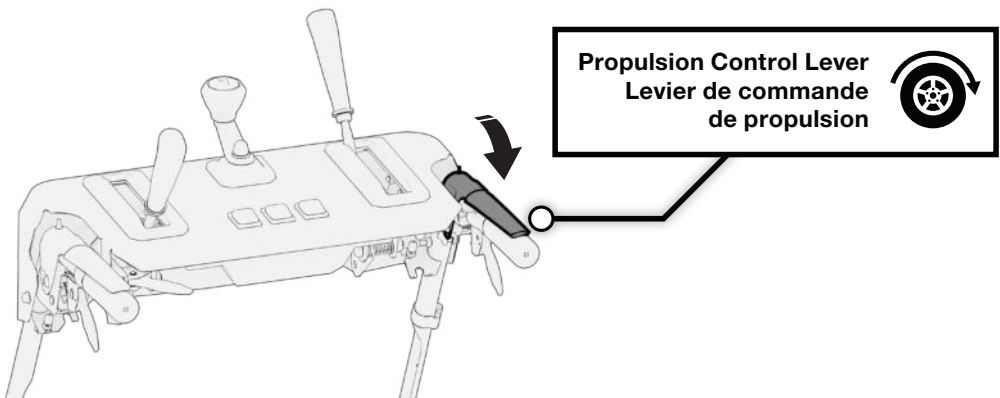

To move, fully press the propulsion control lever into the grip of the right handle.

7.4 ADJUST SPEED / REVERSE

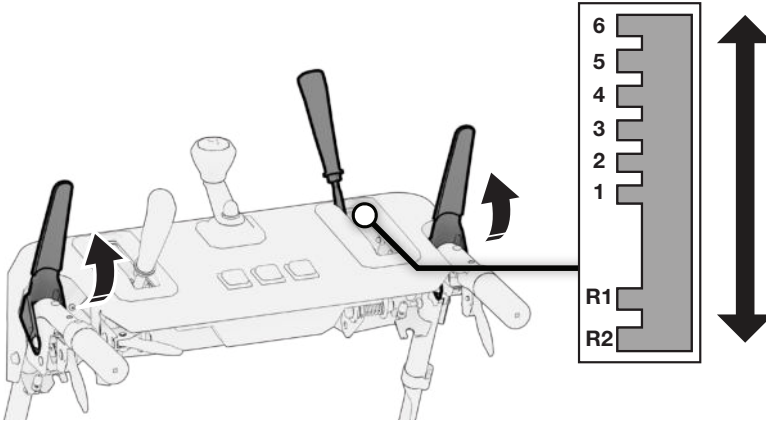

To change speed or reverse, release the propulsion control lever and shift the speed select lever into desired position. Reengage the propulsion control lever.

NOTE

- To stop, release the propulsion control lever. Unit must stop immediately. If it does not: Adjust the propulsion control cable. See Adjusting the Auger and Propulsion Cable.

7.5 ONE-HAND CONTROL

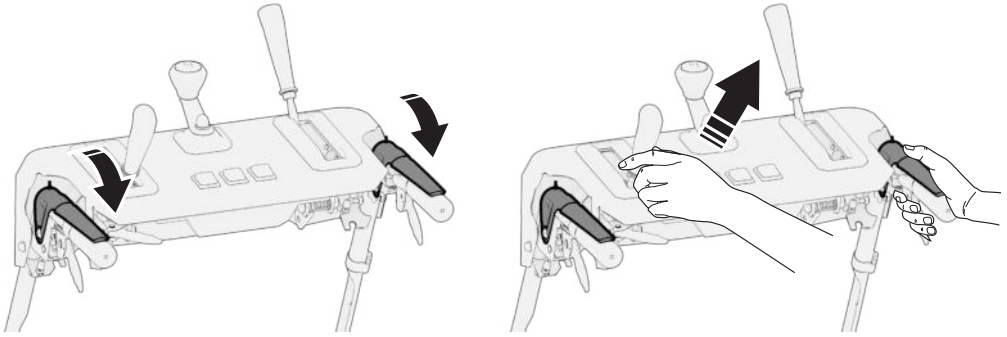

With one-hand control feature, if the propulsion control lever is engaged with your right hand you can release your left hand from the auger control lever to reach other controls without stopping the unit.

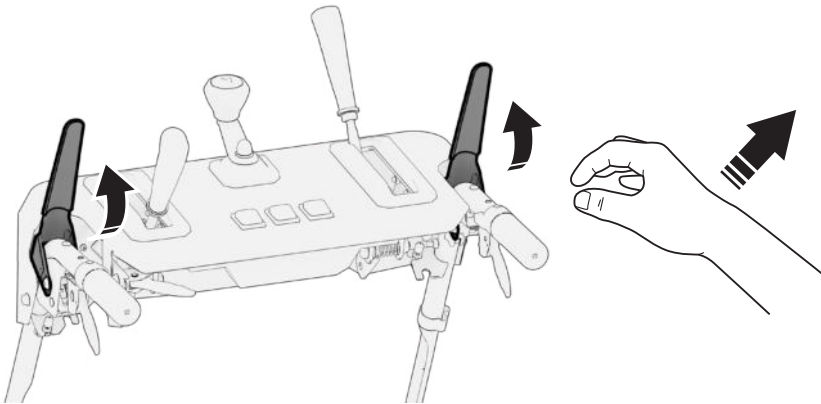

The propulsion control lever must first be released to then release the auger control lever.

NOTE

- If the auger or propulsion cables are too tight or too loose, see Adjusting the Auger and Propulsion Cable chapter.

7.6 USING THE POWER STEERING TRIGGERS

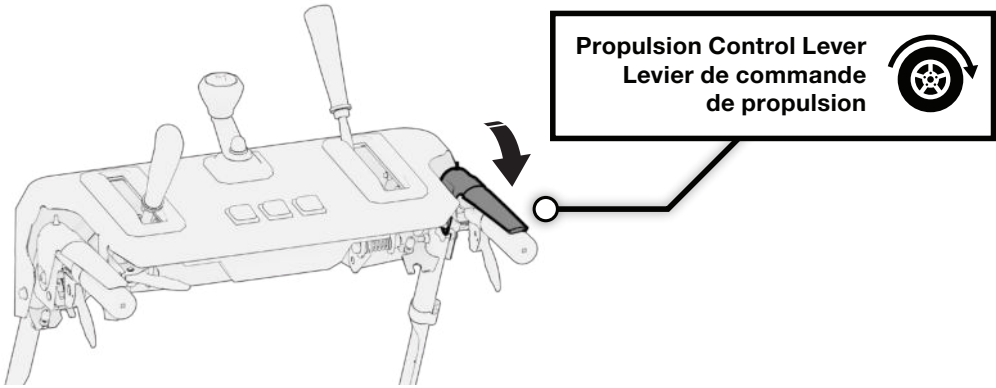

1. Engage the self propulsion lever to move the machine forward.

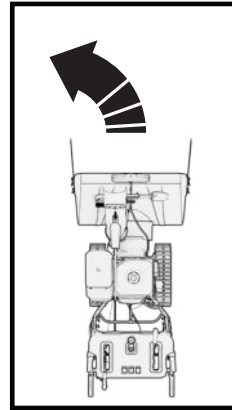
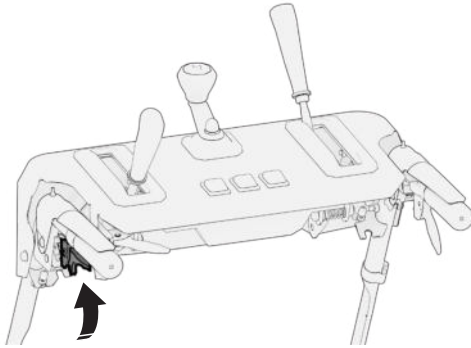

2. Pull up on the left trigger to turn left.
Release the left trigger to continue straight.

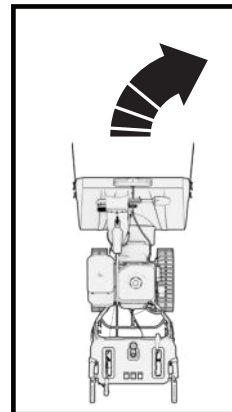
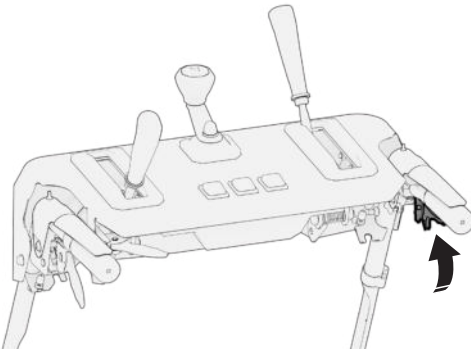

3. Pull up on the right trigger to turn right.
Release the right trigger to continue straight.

7.8 USING THE LIGHTS

To illuminate the area in front of the snowblower, activate the lights by turning the light switches to ON.

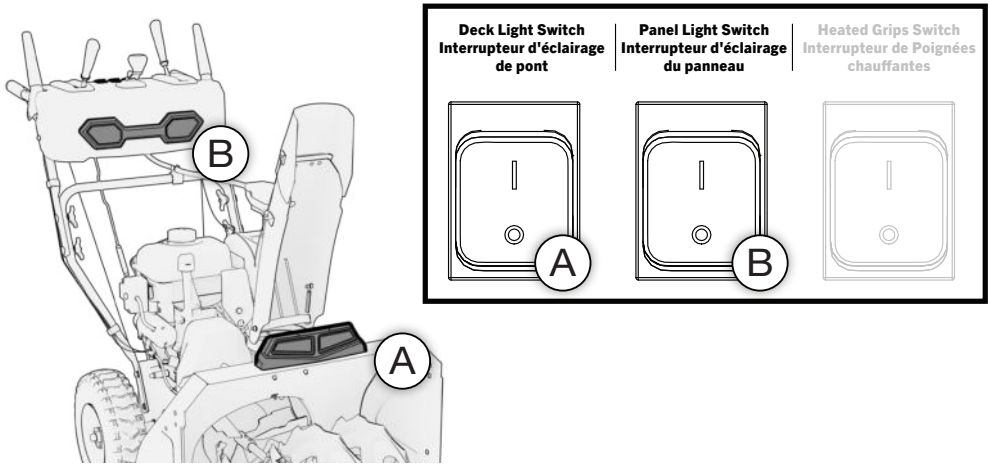

7.7 USING THE HEATED HAND GRIPS

To keep your hands warm in cold weather, activate the heated hand grips by turning the heated hand grips switch to ON.

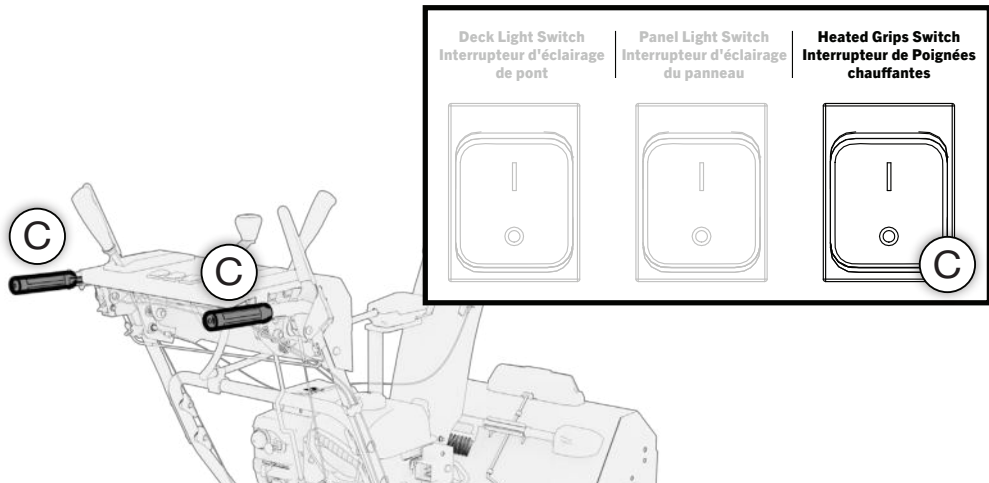

7.9 ADJUSTING THE SKID SHOE HEIGHT

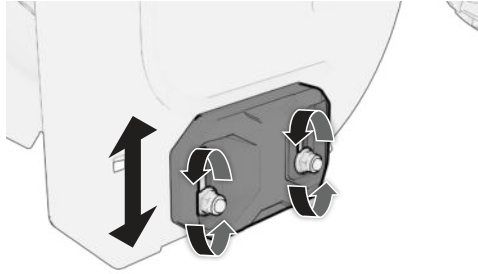

1. When the lock nut is loose or the skid plate is not high enough from the ground, unlock the lock nut.
2. On flat surfaces, like asphalt roads, make the clearance 5-6mm (0.2-0.25 in) higher between the skid plates and the ground with a 13mm open-ended wrench.
On uneven surfaces, like gravel roads, raise the skid shoes so the scraper bar is slightly above the top of the gravel.
Make sure that the gravel and stones do not enter into the snowblower. It will cause personal injuries if those foreign objects are ejected at high speed.
3. Fasten the lock nut.

7.10 CLEARING A CLOGGED DISCHARGE CHUTE

⚠ DANGER! ⚠

Hand contact with the rotating impeller inside the discharge chute is the most common cause of injury associated with snowblowers. The discharge chute contains a rotating impeller to throw snow. Fingers can quickly become caught in the impeller resulting in traumatic amputation or severe laceration. Never clear a clogged discharge chute with your hands. Always use a clean-out tool.

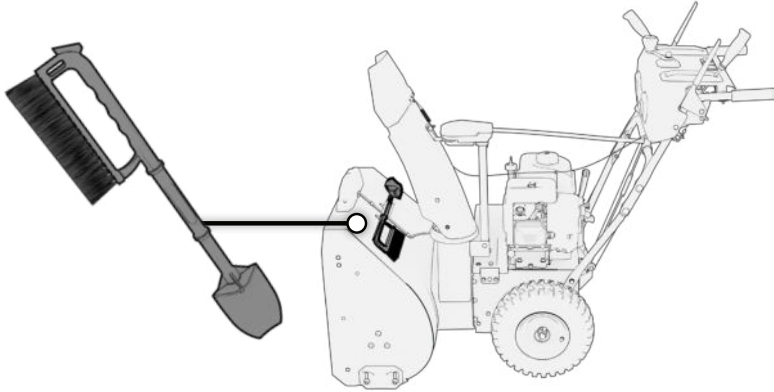

1. Place the unit on a level surface, turn the fuel shut-off valve to CLOSED, and remove the POWER key.
2. Ensure that the impeller has stopped rotating.
3. Use a clean-out tool to remove snow from the discharge chute. NEVER clear a clogged discharge chute with your hands!

8. MAINTENANCE

⚠ WARNING!

Fuel and its vapors are extremely flammable, which could cause burns or fire resulting in death or serious injury. When performing maintenance that requires the unit to be tipped, the fuel tank must be empty, or fuel can leak out and result in a fire or explosion.

Proper maintenance keeps your snowblower in the best operating condition by ensuring safe, economical and trouble-free operation. Only use genuine parts and recommended fluids to replace the worn components. Improper maintenance may cause malfunction and can lead to serious injury. Contact customer support if you have any maintenance questions.

General Inspection Tips

- Look for fuel leaks around the fuel tank, fuel hose, and fuel valve. Close the fuel valve and repair leaks immediately.
- Look and listen for exhaust leaks while the engine is running. Have all the leaks repaired before continuing operation.
- Check for dirt and debris and clean as necessary .
- Check the engine oil level and add oil as necessary.

8.1 MAINTENANCE SCHEDULE

Regular maintenance will improve performance and extend the service life. Maintain the snowblower according to the maintenance schedule below.

NOTE

- Service more frequently when used in dusty areas or adverse conditions.
- These items should be serviced by an authorized service center, unless you have the proper tools and are mechanically proficient. Refer to user guide for service procedures.

Before Each Use
Check engine oil level Check auger and impeller stop time.
First 5 Hours
Change engine oil
First 10 Hours
Change engine oil
Every 3 Months
Lubricate control lever linkages ² Lubricate the discharge chute and deflector ² Lubricate the auger assembly ² Lubricate the hex shaft and gear ² Lubricate the drive wheel axles ²
Every 25 Hours or 12 Months
Change engine oil Inspect/clean spark arrestor Inspect/clean spark plug Inspect/clean fuel line Check tire pressure Check auger and propulsion cable adjustment
Every 200 Hours
Replace spark plug Clean combustion chamber ¹ Inspect/adjust valve clearance ¹ Clean fuel tank and strainer

¹ Recommend service to be performed by authorized service dealer.

² Lubricate the snowblower as outlined in *Lubricating the Snowblower*.

8.2 CHANGING THE ENGINE OIL

⚠ WARNING!

Used motor oil can cause skin irritations if left in long-term contact with skin. Thoroughly wash off used oil as soon as possible with soap and water.

Used oil must be disposed of properly. Do not dispose of used oil in drains or on soil. Local service shops provide environmentally-friendly disposal methods.

Drain the oil rapidly and completely while the engine is still warm.

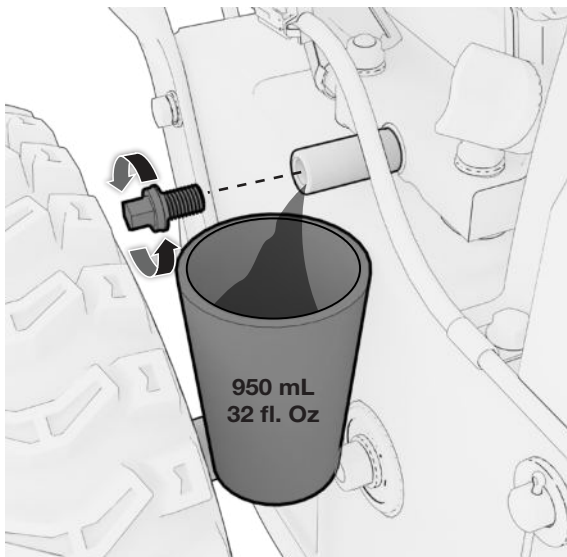
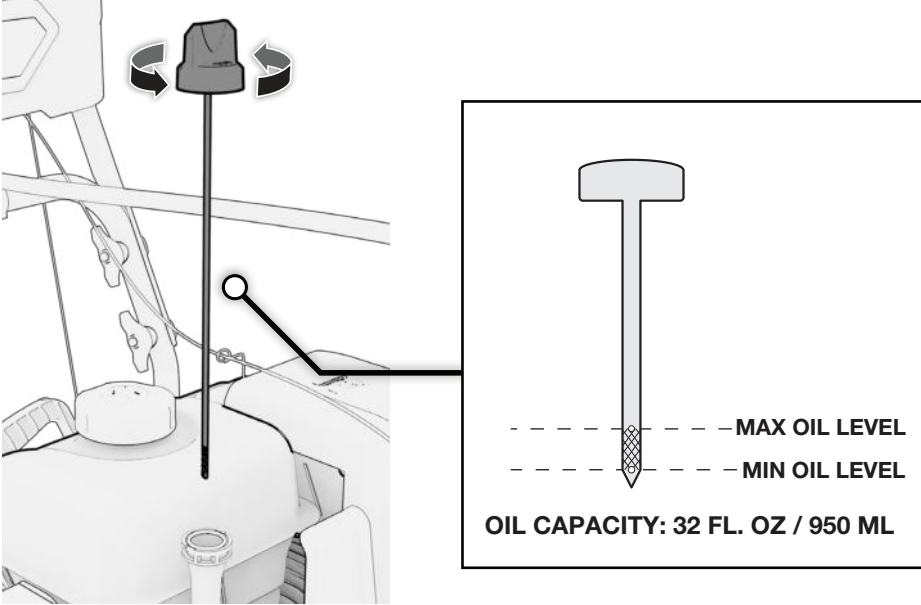

1. With the engine stopped but still warm, place the unit on a level surface and remove the POWER key.
2. Remove the oil drain bolt and tilt the snowblower slightly to drain the oil into an appropriate container.
3. After the oil has drained, reinstall and tighten the oil drain bolt.
4. Clean any moisture or debris from the oil fill area.
5. Remove oil dipstick and wipe with a clean cloth, set aside.
6. Pour engine oil slowly into the engine oil fill tube. Do not overfill.
7. Wait one minute, then insert *without* tightening the dipstick. Remove again to check the oil level, it should be at the top of the full indicator.
8. When the oil level is at the top of the full indicator, reinstall and tighten the dipstick securely.

NOTE

- Oil max. capacity: 32 fl. Oz / 950 mL
- SAE 5W-30 oil is recommended for general use.
- Use of synthetic oil does not change maintenance intervals.
- DO NOT OVERFILL.

EFFECTIVE VISCOCITY RANGE OF ENGINE OILS

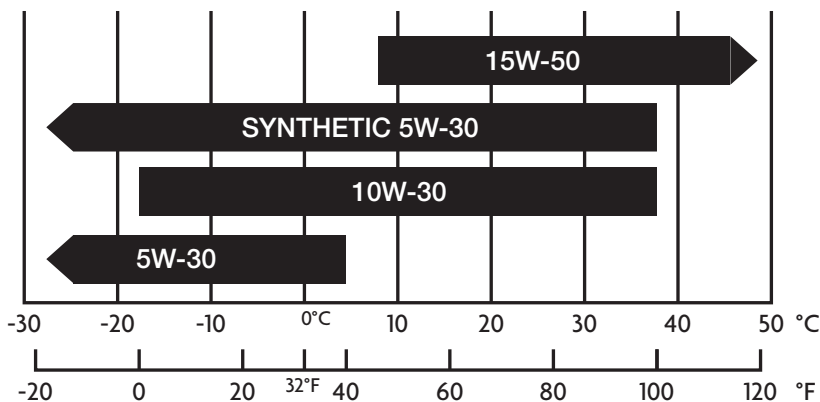

- Do not tilt when adding engine oil. This could result in overfilling and damage to the engine.
- Use high quality 4-stroke engine oil, certified to meet or exceed API standard SG, SF, SAE ratings with strong detergents. Using non-detergent or 2-stroke oil could shorten the engine's working life.
- Do not mix different engine oils.
- Handle and store the engine oil with care, avoid getting dirt or dust into the engine oil.
- To avoid damaging the engine, check the oil level as often as possible.

8.3 SPARK PLUG SERVICE

NOTE

- Do NOT rinse spark plug in water. Follow guidelines and be careful not to overtighten the spark plug.

Recommended spark plug: **F7RTC**

Check the spark plug gap and clean the carbon deposits at the bottom of the spark plug.

Tighten 1/2 turn when installing a new spark plug.

Tighten 1/8 TO 1/4 turn when re-installing an old spark plug.

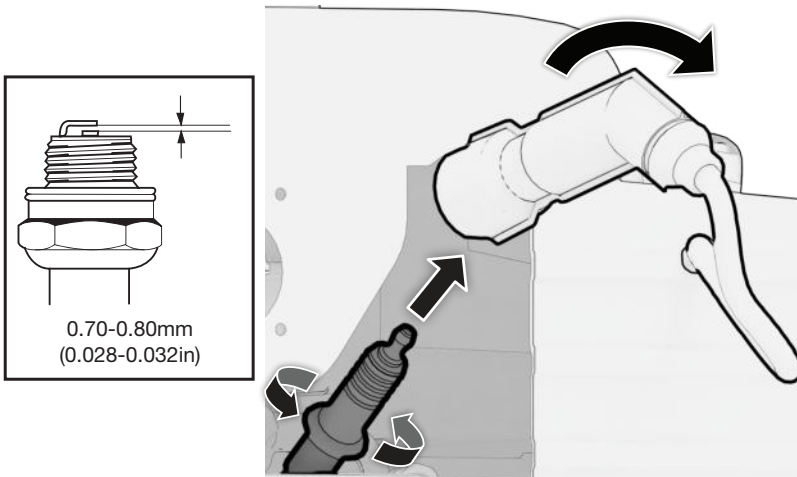

1. Remove the spark plug cap.
2. Remove the spark plug with the spark plug wrench.
3. Visually inspect the spark plug. Replace with a new one if the insulation is cracked or chipped. Clean with a wire brush if the spark plug is reused.
4. Measure the spark plug gap with a feeler gauge. The normal value is: 0.7-0.8mm (0.028- 0.032in). Adjust the gap by carefully bending the electrode.
5. Carefully reinstall the spark plug by hand, to avoid cross-threading. A new spark plug should be tightened 1/2 turn with a wrench. A used spark plug should be tightened 1/8 to 1/4 turn with wrench.
6. Reinstall the spark plug cap.

NOTE

- The spark plug must be securely tightened or it could cause the spark plug to heat up enough to damage the engine.
- Never use a spark plug with an improper heat range.

8.4 SPARK ARRESTER MAINTENANCE

⚠ WARNING!

U.S.A. Models: The engine exhaust from this product contains chemicals known to the State of California to cause cancer, birth defects, or other reproductive harm.

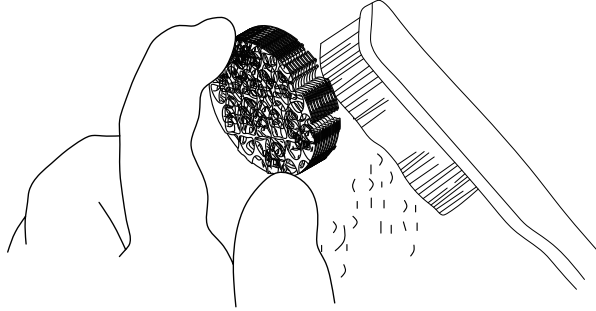

1. Take off the spark arrester from the muffler (after the engine has cooled down)
2. Use a brush to remove carbon deposits from the spark arrester. If the spark arrester is worn down, replace it.
3. Reinstall the spark arrester, muffler guard, and casings.

8.5 FUEL FILTER MAINTENANCE

⚠ WARNING!

Gasoline is highly flammable and explosive under certain conditions. Refuel in a well-ventilated area with the engine stopped. Do not smoke or allow open flames or sparks in the area where the snowblower is being refueled or where gasoline is stored. Do not overfill the tank. Be careful not to spill fuel when refueling. Wipe up any spilled gasoline and let the area dry before starting the engine.

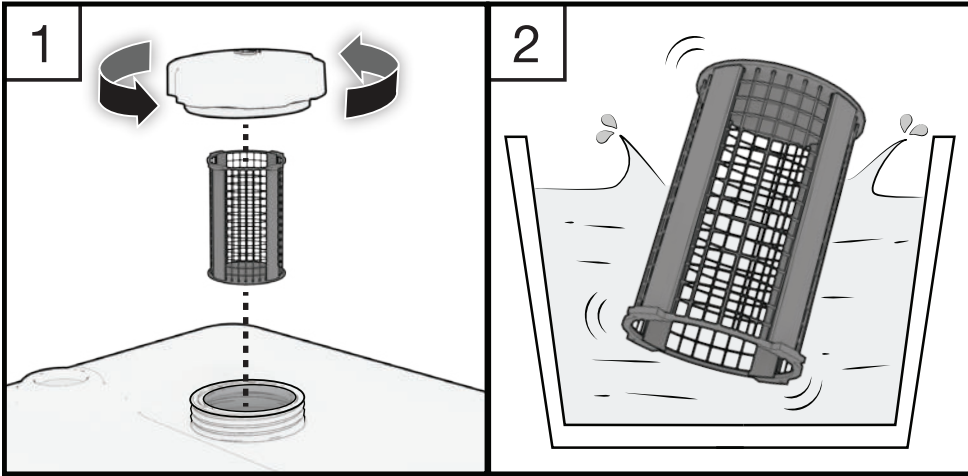

1. Remove the fuel cap and filter.
2. Clean the filter with solvent.

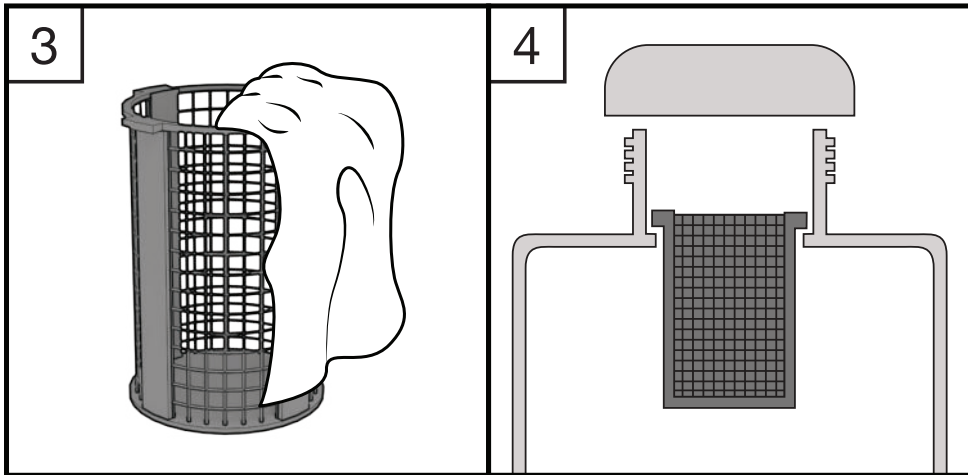

3. Wipe the filter.
4. Reinsert the filter.

8.6 LUBRICATING THE SNOWBLOWER

Lubricate the following locations at least once per year, or every 25h of use.

1. Place the unit on a level surface, turn the fuel shut-off valve to CLOSED, and remove the POWER key.
2. Position speed select lever in the first forward gear.
3. Lubricate the control lever linkage with fresh, clean **engine oil**.
4. Lubricate the chute deflector with fresh, clean **engine oil**.
5. Lubricate the discharge chute with **lithium grease**.
6. Lubricate both wheel axles with **lithium grease**.
7. Lubricate the auger shaft assembly with **grease**.
8. Place cardboard or a towel in front of the auger housing, then pivot the snowblower up on the front of the auger housing.
9. Remove screws from bottom panel and remove the panel.
10. Taking great care not to allow grease or oil to contact the friction wheel or disc drive plate, pour a small amount of fresh, clean **engine oil** to a clean cloth and wipe oil onto the hex shaft.
11. Move the speed select lever to highest gear and wipe oil onto remaining half of hex shaft.
12. Lubricate the sprocket and chain with fresh, clean **engine oil**.

Reinstall bottom panel and pivot snowblower down onto the wheels.

8.7 ADJUSTING THE AUGER AND PROPULSION CABLES

The augers should rotate only when the auger control lever is engaged and must stop within 5 seconds of the auger control lever being released. The wheels should only move when propulsion control lever is engaged and must stop immediately when the propulsion control lever is released. If the auger or wheels do not stop as described, adjust the control cable or contact an authorized service dealer to adjust the control cable.

Over-tightening the auger or propulsion cables may cause the auger or wheels to rotate even if the control levers are not engaged. Follow the adjustment procedure to ensure the cables are not over-tightened.

Locate the adjuster for the cable that needs to be adjusted.

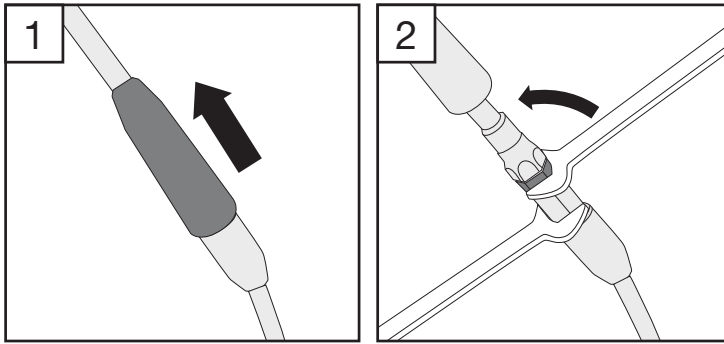

1. Slide off the protective covers to reveal the adjuster underneath.
2. Locate the longest section and the locking nut. Use wrench to hold the long section stationary. Loosen the locking nut with wrench.

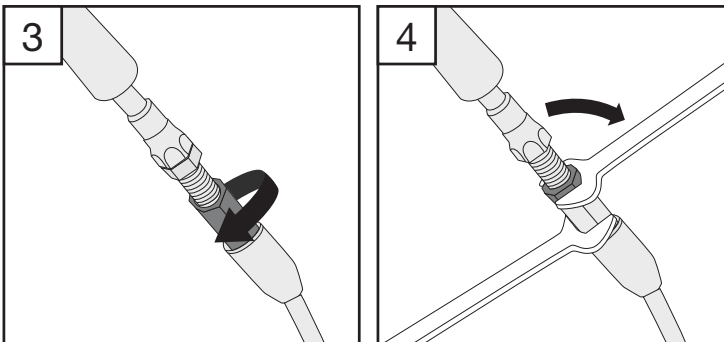

3. Set the tension by adjusting the longest section.
4. Once the tension has been set, re-tighten locking nut. Re-slide the two protective covers over the adjuster.

8.8 ADJUSTING THE POWER STEERING CABLES

The power steering cables may stretch after repeated usage during the first year of operation. If the cable has stretched, it may prevent the drive gears from disengaging when the control is activated.

Locate the adjuster for the cable that needs to be adjusted.

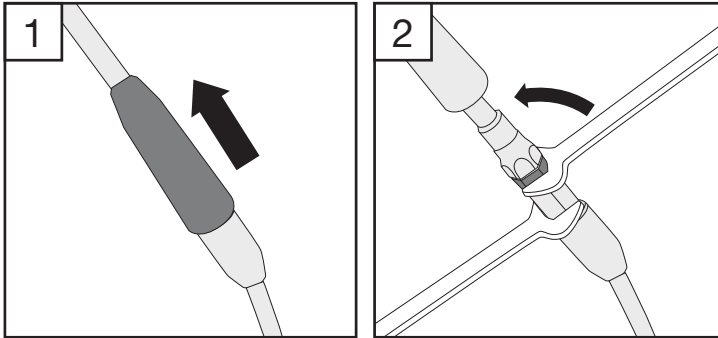

1. Slide off the protective covers to reveal the adjuster underneath.
2. Locate the longest section and the locking nut. Use a wrench to hold the long section stationary. Loosen the locking nut with another wrench.

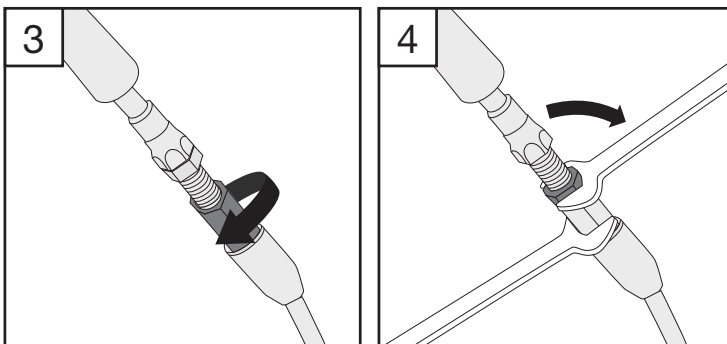

3. Set the tension by adjusting the longest section.
4. Once the tension has been set, re-tighten locking nut.
5. Re-slide the two protective covers over the adjuster.

8.9 REPLACING THE AUGER SHEAR BOLT

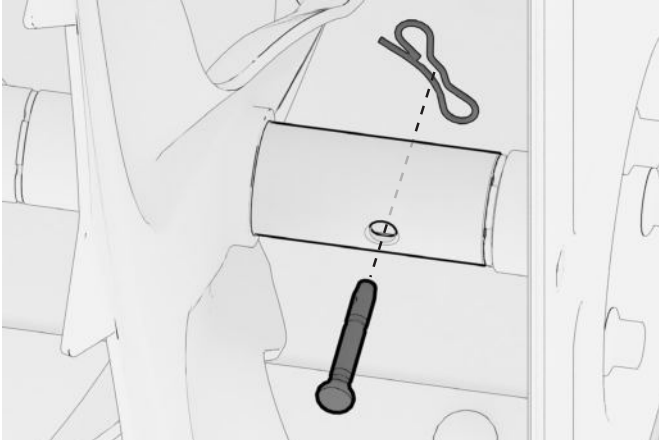

1. Place the unit on a level surface, turn the fuel switch to CLOSED, and remove the POWER key.
2. Remove the existing shear bolt and pin clip.
3. Add grease to the auger shaft assembly. Spin the auger to lubricate the auger shaft.
4. Align the bolt holes. Attach a new shear pin (A) and a new bowtie clip (B).

8.8 REPLACING THE SCRAPER BAR

Over time the scraper bar will gradually wear and need replacement.

Snowblower Placement

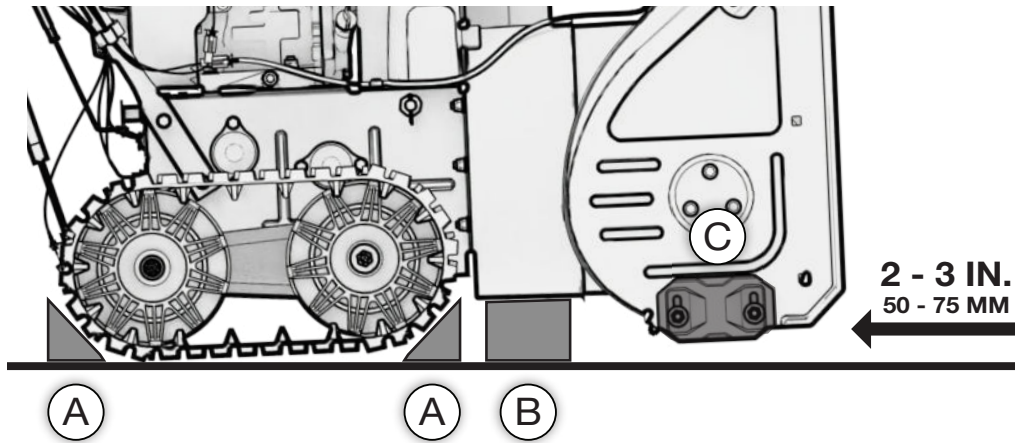

1. Place the unit on a level surface, turn the fuel shut-off valve to CLOSED, and remove the POWER key.
2. Place wheel chucks (A) behind and in front of tracks to prevent the unit from rolling.
3. Place a block of wood (B) under auger housing just behind the scraper blade such that the skid shoes (C) are about 2-3in off the ground. Note: To reduce the chance of injury, it is recommended to have a second person aid in this step.

NOTE

- To reduce the risk of injury, we recommend that a second person assists you at this stage.

Scraper Bar Replacement

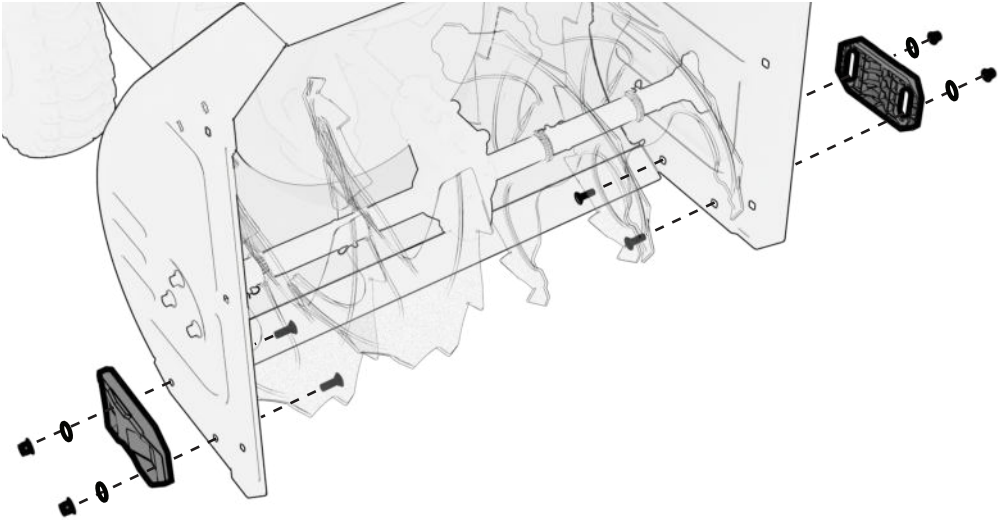

1. Loosen and remove nuts. Remove skid shoes and carriage bolts.

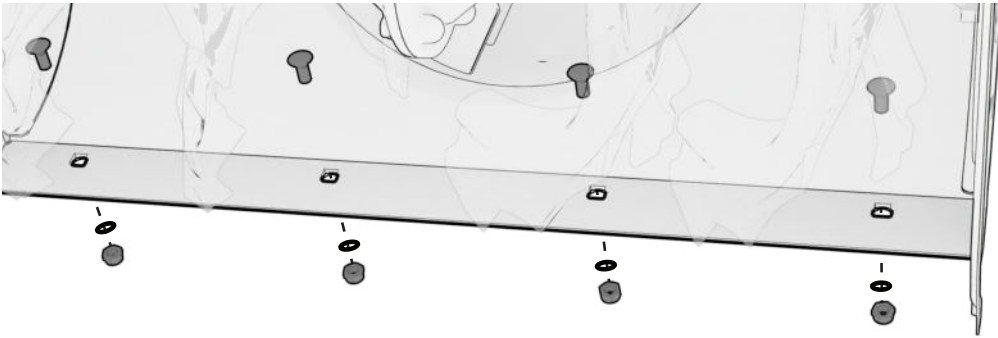

2. Loosen and remove nuts. Remove carriage bolts.

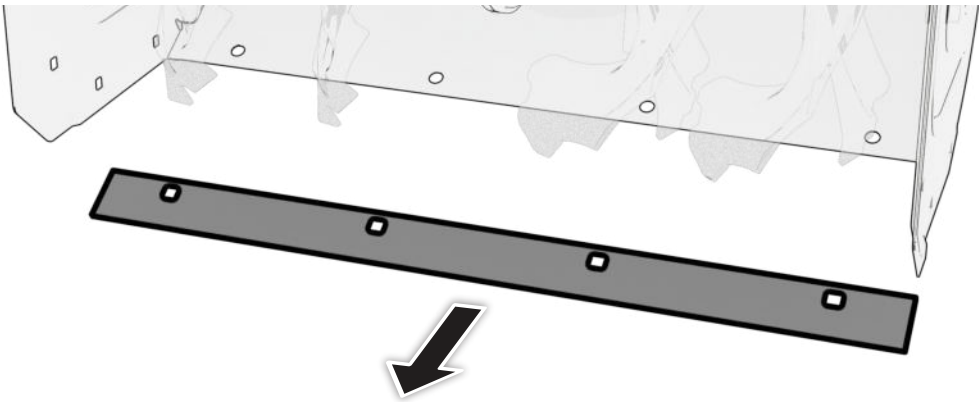

3. Remove the scraper and replace it with a new one.
4. To reassemble, repeat the disassembly in reverse.

8.11 CARBURETOR MODIFICATION FOR HIGH ALTITUDE OPERATION (Above 2000 feet)

NOTE

- This engine is equipped to run at altitudes below 2,000-ft.
- A high-altitude Main Jet is recommended when operated at 2,000 to 7,000-ft above sea level.
- At elevations above 7,000-ft the engine may experience decreased performance even with a high-altitude Main Jet.

At high altitudes the carburetor's air/fuel mixture becomes too rich, resulting in higher fuel consumption, lower performance, and carbon build-up on the spark plug. On the other hand, if the carburetor has been modified for high altitude operation and is operated below 2000-ft, the air/fuel mixture will then be too lean for low altitude use. Always use the correct Main Jet for your altitude.

The engine's carburetor, governor (if so equipped), and any other parts that control the air/fuel ratio will need to be adjusted by a qualified mechanic to allow efficient high-altitude use, and to prevent damage to the engine and any other devices used with this product. The fuel system on this engine may be influenced by operation at higher altitudes.

- Carburetor bowl may have gas in it which will leak upon removing the bolt.
- The mixing tube is held in place by the Main Jet and might fall out when it is removed. If it falls out, replace it in the same orientation before replacing the Main Jet.
- The Fuel Cup Seal and Bolt Seal may be damaged during removal and should be replaced with the new ones.

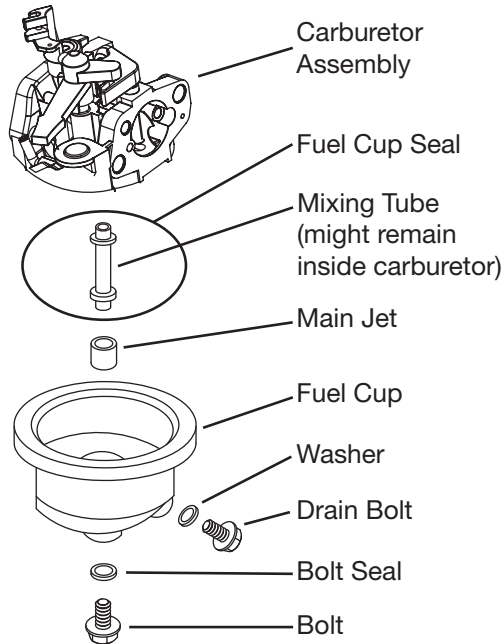

1. Turn off the engine.
2. Close the fuel valve.
3. Place a bowl under the fuel cup to catch any spilled fuel.
4. Unthread the bolt holding the fuel cup.
5. Remove the bolt, Bolt Seal, fuel cup, Fuel Cup Seal and Main Jet from the body of the carburetor assembly. A carburetor screwdriver (not included) is needed to remove and install the Main Jet.
6. Replace the Main Jet with the replacement Main Jet needed for your altitude range.
7. Replace the Fuel Cup Seal, fuel cup, Bolt Seal, and bolt. Tighten in place. Do not cross thread bolt when tightening. Finger tighten first and then use a wrench to make sure the bolt is properly threaded.
8. Wipe up any spilled fuel and allow excess to evaporate before starting engine. To prevent FIRE, do not start the engine while the smell of fuel hangs in the air.

8.12 EMISSION CONTROL SYSTEM

Emission Source

Exhaust gas contains carbon monoxide, nitrogen oxides (NOx) and hydrocarbons. It is very important to control the emissions of NOx and hydrocarbons as they are a major contributor to air pollution. Carbon monoxide is a poisonous gas. The emission of fuel vapors is a source of pollution as well. The engine utilizes a precise air-fuel ratio and emission control system to reduce the emissions of carbon monoxide, NOx, hydrocarbons and evaporative fuel emissions.

Regulation

Your engine has been designed to meet current Environmental Protection Agency (EPA) standards. The regulations dictate that the manufacturer provides operation and maintenance standards regarding the emission control systems. Tune up specifications are provided in the Specifications section and a description of the emission control system may be found in the appendix to this manual. Adherence to the following instruction will ensure your engine meets the emission control standards.

Modification

Modification of the emission control system may lead to increased emissions. Modification is defined as the following:

- Disassembling or modifying the function or parts of the intake, fuel or exhaust system.
- Modifying or destroying the speed governing function of the snowblower.

Engine faults that may affect emission

Any of the following faults must be repaired immediately. Consult with your authorized service centre for diagnosis and repair:

- Hard starting or shut down after starting.
- Unstable idle speed.
- Shut down or backfire after applying an electrical load.
- Backfire or after fire.
- Black smoke and/or excessive fuel consumption.

Replacement parts and accessories

The parts making up the emission control system in your product's engine have been specifically approved and certified by the regulatory agencies. You can trust that the replacement parts supplied by customer service have been manufactured to the same production standard as the original parts. The use of aftermarket replacement parts or accessories may negatively affect the engine emission performance. Therefore only use replacements parts and accessories from a qualified service centre to guarantee that the replacement products will not adversely affect emission performance.

Replacement parts other than those from an authorized service centre will void the warranty.

9. TRANSPORTATION & STORAGE

Draining the Fuel Tank

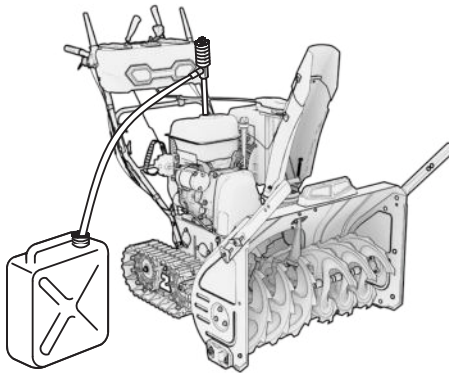

Drain the old gas and completely fill the tank with fresh gas. Add a fuel stabilizer according to the manufacturer's directions to keep your fuel fresh over long periods, we recommend B3C fuel additives. Run the engine for 2 minutes to circulate the fuel stabilizer.

Transporting the Snowblower

1. Do not overfill the fuel tank (No residual fuel on the neck of tank).
2. Avoid exposing the snowblower to prolonged direct sunlight while in an enclosed vehicle. The high temperature inside the vehicle could cause fuel to vaporize resulting in a possible explosion.
3. Drain the snowblower of fuel and oil before being transported on rough roads.

Storage

Gasoline can oxidize in as little as 30 days, causing gum and varnish to build up in fuel system components.

Storage Duration	Preparation Required
Less than 1 Month	<ul style="list-style-type: none">■ No storage preparation required, simply store as is.
1 Month to 1 Year	<ul style="list-style-type: none">■ Drain the old gas and completely fill the tank with fresh gas before storage. Add fuel stabilizer according to the manufacturer's directions. Adding a quality fuel stabilizer can keep gas fresh for up to a year.
1 Year or More	<ul style="list-style-type: none">■ Drain off the gasoline from the fuel tank, and store in a suitable container. This will help prevent deposits from forming in the fuel system.■ Turn the fuel switch to OPEN and loosen the carburetor drain bolt. Take off the spark plug cap and revolve the engine 3 or 4 times, by pulling the recoil handle, to fully discharge the gasoline from the fuel lines.■ Turn the fuel switch to CLOSED and tighten the drain bolt of the carburetor.■ Change oil while engine is still warm from operation.■ Remove the spark plug, and pour a tablespoon of clean engine oil (10~20ml) into the cylinder. Revolve the engine several times by pulling on the recoil start to distribute the oil. Reinstall the spark plug. Pull the starter grip slowly until you feel resistance. At this point, the piston is coming up on its compression stroke and both the intake and exhaust valves are closed. This position helps to protect the engine from internal corrosion.

NOTE

- Ensure that the storage area is free of excess humidity and dust.

10. TROUBLESHOOTING

Problem	Look for	Solution
Auger does not stop within 5 seconds after auger control lever is released.	Auger control cable out of adjustment.	See Adjusting the Auger and Traction Cable.
Discharge chute or deflector does not work.	Discharge chute or deflector out of adjustment or needs lubrication.	Adjust and/or lubricate control linkage.
Scraper bar does not clean hard surface.	Skid shoes and scraper bar improperly adjusted.	See Adjusting the Skid Shoe Height.
Unit does not propel itself.	Traction control cable out of adjustment.	See Adjusting the Auger and Traction Cable.
Engine does not start.	Key is in OFF position.	Turn key to ON position.
	Primer button not pressed (cold engine).	Press primer button twice and restart.
	Fuel shut-off valve (if equipped) is in CLOSED position.	Turn valve to OPEN position.
	Out of fuel.	Fill fuel tank.
	Choke turned to OPEN/RUN (cold engine).	Turn choke to CLOSED/START, set throttle to FAST.
	Engine flooded.	Move the choke to OPEN/RUN position, move throttle to FAST position, and crank until the engine starts.
Engine is hard to start or runs poorly.	Water in fuel, or old fuel.	Fill with fresh fuel.
	Fuel cap vent is blocked.	Clear vent or replace fuel cap.

Excessive vibration.	Loose parts or damaged impeller.	Stop engine immediately. Tighten all hardware. If vibration continues, have the unit serviced by an Authorized Dealer.
Snowblower does not stop when traction control lever is released.	Traction control cable out of adjustment.	See Adjusting the Auger and Traction Cable.
Unit does not discharge snow.	Auger control cable out of adjustment.	See Adjusting the Auger and Traction Cable.
	Broken auger shear bolt.	See Replacing the Auger Shear Bolt.
	Broken impeller shear bolt.	See Replacing the Impeller Shear Bolt.
	Discharge chute clogged.	STOP THE ENGINE! Ensure that the auger and impeller have stopped rotating. Use a clean-out tool to remove snow from the discharge chute. Never clear a clogged discharge chute with your hands! See Clearing a Clogged Discharge Chute.
	Foreign object lodged in auger.	STOP THE ENGINE! Ensure that the auger and impeller have stopped rotating. Use a clean-out tool to remove foreign object. Never clear a lodged object with your hands! See Clearing a Clogged Discharge Chute.
Snowblower does not turn when steering trigger is engaged.	Steering cable out of adjustment.	See Adjusting the Steering Feature Cable.

10.1 OIL AND GAS TROUBLESHOOTING

Engine is Smoking



Too Much Oil



Solution:

1. Turn off device, wait for engine to cool.
2. Place the device on a level surface.
3. Follow steps in your manual to completely drain your device of all engine oil. DO NOT re-use oil. Dispose of used oil properly.
4. Use an oil container with volume measurements to measure out the exact right amount of engine oil. The manufacturer recommended oil volume will be noted on the engine or in the user manual.
5. Use a funnel to transfer oil from the container to the engine.

Residual oil may still be left in the combustion chamber from previously. Run device on idle until the engine's exhaust stops smoking and the engine runs normally. Stay away from any fumes when performing maintenance. Contact customer service if problem persists.

**Low Performance,
Excessive Noise / Vibrations**



Not Enough Oil



Solution:

1. Turn off device, wait for engine to cool.
2. Place the device on a level surface.
3. Remove the oil intake cap and dipstick. Clean dipstick with a clean, dry cloth and gently insert into oil intake hole (Do NOT rotate or thread the dipstick, this will cause an inaccurate reading).
4. If you detect oil, follow steps in your manual to completely drain your device of all engine oil. DO NOT re-use oil. Dispose of used oil properly.
5. Use an oil container with volume measurements to measure out the exact right amount of engine oil. The manufacturer recommended oil volume will be noted on the engine or in the user manual.
6. Use a funnel to transfer oil from the container to the engine.

Run device on idle, the engine should run normally. Contact customer service if problem persists.

**How do I make sure
I have enough oil?**



Most Accurate:

1. Follow steps in your manual to completely drain your device of all engine oil.
DO NOT re-use oil. Dispose of used oil properly.
2. Use an oil container with volume measurements to measure out the exact right amount of engine oil. The manufacturer recommended oil volume will be noted on the engine or in the user manual.

OR

Less Accurate:

1. Remove the oil intake cap and dipstick. Clean dipstick with a clean, dry cloth.
2. Gently insert into oil intake (Do NOT rotate or thread the dipstick, this will cause an inaccurate reading).
3. Remove dipstick and check oil level. Oil should be in-between the empty and full lines.
4. If it is close to the empty line, it is recommended to add more oil, or to change the oil if it appears significantly dark or sparkly.

**How often do I
change my oil?**



First Oil Change (~5 Hours):

1. Fill the new unit with the appropriate amount of oil and type (according to product manual).
2. Run the unit for 5 hours.
3. Drain oil and replace with fresh oil.
DO NOT re-use oil that has already been used.



Second Oil Change (~10 Hours):

1. Once the first cycle of oil has been replaced, run the unit for another 10 hours.
2. Drain and replace with fresh oil again.



**Consecutive Oil Changes
(Every 25 Hours):**

1. After the initial 'break-in' oil changes, replace oil every 25 hours of use.

11. TECHNICAL SPECIFICATIONS

SPECIFICATIONS		5554-051
ENGINE	Type	4-stroke, overhead valve, single cylinders, forced-air cooling
	Engine Displacement	302 cc
	Horsepower	9 HP
	Engine Speed	3600 rpm
	Spark Plug	F7RTC
	Spark Plug Gap	0.028 - 0.032 in (0.7-0.8mm)
	Start System	Electric, and Recoil
	Fuel Capacity	1.19 Gal / 4.5 L
	Fuel Type	Unleaded Gasoline
	Oil Capacity	32 fl. Oz / 950 mL
	Oil Type	5W-30
SNOWBLOWER	Stages	2
	Deck Width	28 inch
	Deck Height	21 inch
	Chute Rotation	Dash Mounted
	Number of Speeds	6F / 2R
	Max Throwing Distance	40 ft / 12 m
	Min Throwing Distance	3.3 ft / 1 m
	Skid Material	Plastic
	Dimensions (L*W*H)	53.9 x 29.5 x 45.1 in
	Net Weight	198 lbs / 89.8 kg

12. APPENDIX

The standard condition of rated power output:

Altitude: 0m

Ambient temperature: 77°F (25°C)

Relative humidity: 30%

Factor of Environment Correction:

Altitude (m)	Ambient Temperature°F (°C)				
	77° (25°)	86° (30°)	95° (35°)	104° (40°)	113 (45°)
0	1	0.98	0.96	0.93	0.90
500	0.93	0.91	0.89	0.87	0.84
1000	0.87	0.85	0.82	0.80	0.78
2000	0.75	0.73	0.71	0.69	0.66
3000	0.64	0.62	0.60	0.58	0.56
4000	0.54	0.52	0.50	0.48	0.46

NOTE:

Relative humidity 60% correction factor C-0.01

Relative humidity 80% correction factor C -0.02

Relative humidity 90% correction factor C-0.03

Relative humidity 100% correction factor C-0.04

Example:

Rated power (PN) 2.8kVA snowblower (Altitude: 1000m) Ambient temperature:
35°C, Relative humidity: 80%

$$P=P_n*(C-0.02)=2.8*(0.82-0.02)=2.24kVA$$

13. LIMITED WARRANTY

Warranty

Beginning at the time of retail purchase and for the duration of the warranty period Midland Power Inc. (Midland) warrants that Equipment manufactured by it is warranted to be free from defects in material and workmanship. Midland will, at its sole discretion, replace or repair any part(s) which, upon evaluation and testing by Midland or an authorized service center, show a defect in workmanship or material. Valid proof of purchase must be submitted online for registration with Midland, or presented to Midland at time of claim, for warranty to be valid. This warranty is not transferable from the original owner.

Limited Warranty Period:

Non-commercial use:

- Year 1, 2 and 3 - Parts and Labour
- Year 4 and 5 - Parts

Commercial use:

- First 6 Months - Parts and Labour

Commercial use includes utilization of the purchased product for a business or non-profit organization, or to financially benefit an individual. This includes, but is not limited to, usage in the context of a financial transaction, usage on commercial or non-profit property, or usage for advertising or marketing purposes.

Replacement parts sold to a consumer or installed by an authorized service center are warranted for a period of 90 days from date of purchase. Labour must be performed by an authorized service center unless given Midland's prior written approval. Midland will not bear any transportation or shipping fees to or from an authorized service center. Service calls, travel charges, overtime, or weekend rates, are not covered.

This warranty does NOT cover:

- a. Any repairs required as a result of any parts not supplied by Midland, and/ or repair of parts that are not responsible for the failure or malfunction;
- b. Any Equipment modified, altered, disassembled or remodelled;
- c. Any repairs required as a result of a failure to install, maintain, store, transport, or operate the Equipment in accordance with standard practices set out in the user guide;
- d. Damage that occurred after receipt of equipment, not caused by defects in workmanship or material;
- e. Normal maintenance services, as outlined in the user guide and intended for a consumer to perform;

- f. Replacement of parts made in connection with normal maintenance services including oils, adhesives, additives, fuel, filters, brushes, belts, lubricants, spark plugs, gaskets, seals, fasteners, wires, tubes, pipes, fittings, wheels, batteries, and other expendables susceptible to natural wear;
- g. Any accessory or attachment.

Any battery supplied with this Equipment is considered a consumable item and is excluded from this warranty. Batteries can be damaged by shock, shorting terminals, heat, acid spillage, neglect, and other factors. It is the customer's responsibility to take great care when handling a battery so no spillage of acid occurs which may cause corrosion.

Midland disclaims any responsibility for loss of time or use of the product, transportation, or towing costs or any other indirect, incidental, or consequential damage, inconvenience or commercial loss.

This warranty is the entire and only warranty given by Midland for Midland products or equipment. No agent or employee is authorized to extend or enlarge this warranty on behalf of Midland by any written or verbal statement or advertisement.

Other States, U.S. territories, and Canada

In other areas of the United States and in Canada, your engine must be designed, built, and equipped to meet the U.S. EPA and Environment Canada emission standards for spark-ignited engines at or below 19 kilowatts.

All of the United States and Canada

Midland Power Inc. must warrant the emission control system on your power equipment engine for the period of time listed below, provided there has been no abuse, neglect, or improper maintenance of your power equipment engine. Where a warrantable condition exists, Midland Power Inc. will repair your power equipment engine at no cost to you including diagnosis, parts, and labor.

Your emission control system may include such parts as the carburetor or fuel injection system, the ignition system, and catalytic converter. Also included may be hoses, connectors, and other emission-related assemblies.

Emission Control System Warranty Parts:

This list applies to parts supplied by Midland Power Inc. and does not cover parts supplied by the equipment manufacturer. Please see the original equipment manufacturer's emissions warranty for non-Midland Power Inc. parts.

Consumable parts are covered up to a maximum of 30 days.

SYSTEMS COVERED IN WARRANTY	PARTS DESCRIPTION
Fuel Metering	Fuel assembly (includes starting enrichment system), Engine temperature sensor, Engine control module, Fuel regulator, Intake manifold
Evaporative	Fuel Tank, Fuel Cap, Fuel Hoses, Vapor Hoses, Carbon Canister, Canister Mounting Brackets, Fuel Strainer, Fuel cock, Fuel Pump, Fuel Hose Joint, Canister Purge Hose Joint
Exhaust	Catalyst, Exhaust Manifold
Air Induction	Air filter housing, Air filter element
Ignition	Flywheel magneto, Ignition pulse generator, Crankshaft position sensor, Power coil, Ignition coil assembly, Ignition control module, Spark plug cap, Spark plug
Crankcase Emission Control	Crankcase breather tube, Oil filler cap
Miscellaneous Parts	Tubing, fittings, seals, gaskets, and clamps associated with these listed systems



Customer Service

Online: www.benchmark.midlandpowerinc.com

Toll Free: 1-877-528-3772

Enjoy!

Be sure to check www.benchmark.midlandpowerinc.com for updates regarding your product.





BENCHMARKTM_{MC}

5554-051