

Dyna-Glo®

LPFAB60DG Propane Construction Heater

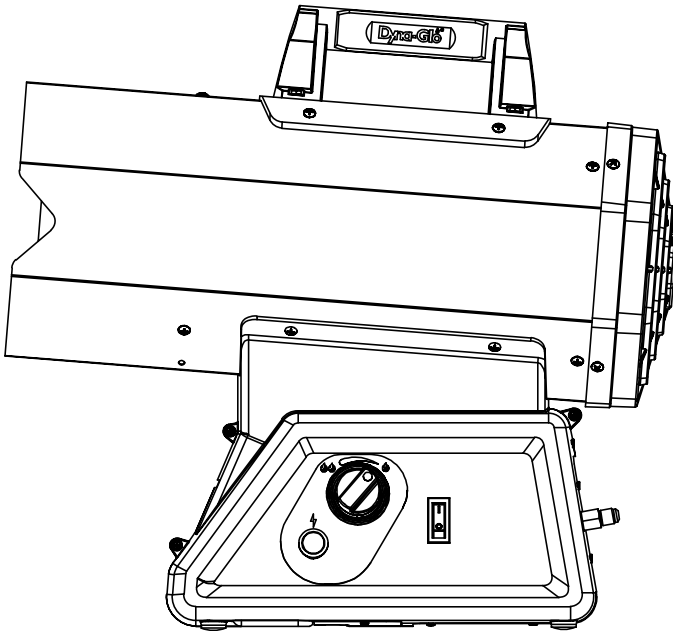

OPERATOR'S MANUAL



CAUTION: To Reduce The Risk Of Injury, User Must Read And Understand Operator's Manual. Save These Instructions For Future Reference.

TABLE OF CONTENTS

Propane Forced Air Construction Heaters.....	2
Air Quality Hazard	2
Specifications	4
General Safety Instruction.....	5
Important Safety Instruction.....	5
Product Features.....	6
Unpacking The Heater	6
Information On Size Capacity Of Propane Gas Cylinders.....	7
Installation To The Propane Gas Tank	8
Refilling The Propane Gas Tank.....	8
Battery Installation and Removal Instructions	9
Extension Cord Attachment.....	9
Heater Tilt Adjustment Instructions.....	9
Propane Safety	10
Leak Checking.....	10
Lighting Instructions.....	10
Shutdown Instructions	11
Test Firing Heater	11
Storage.....	11
Maintenance Instructions.....	11
Replacement parts	11
Troubleshooting.....	12
Wiring Diagrams.....	13
Replacement Parts List	14
Warranty	16

⚠ GENERAL HAZARD WARNING: Failure to comply with the precautions and instructions provided with this heater, can result in death, serious bodily injury and property loss, or damage from the hazards of fire, explosion, burn, asphyxiation, carbon monoxide poisoning, and/or electrical shock.

Only persons who can understand and follow the instructions should use or service this heater.

If you need assistance or heater information such as an instruction manual, labels, et cetera, contact the manufacturer.

⚠ WARNING: Fire, burn, inhalation, and explosion hazard, keep solid combustibles, such as building materials, paper or cardboard, a safe distance away from the heater as recommended by the instructions.

Never use the heater in spaces which do or may contain volatile or airborne combustibles, or products such as gasoline, solvents, paint thinners, dust particles or unknown chemicals.

⚠ WARNING: This product and the fuels used to operate this product (propane), and the products of combustion of such fuels, can expose you to chemicals including benzene, which is known to the State of California to cause cancer and birth defects or other reproductive harm. For more information go to www.p65Warnings.ca.gov

⚠ WARNING: Not for home or recreational vehicle use.

PROPANE FORCED AIR CONSTRUCTION HEATERS

The heater is designed and approved for use as a construction heater under CSA/ANSI Z83.7 / CSA 2.14. It is hard to anticipate every use which may be made of this heater. **CHECK WITH YOUR LOCAL FIRE SAFETY AUTHORITY IF YOU HAVE QUESTIONS ABOUT APPLICATIONS.**

Other standards govern the use of fuel gases and heat producing products in specific applications. Your local authority can advise you about these.

IMPORTANT: READ THIS USER'S MANUAL CAREFULLY AND COMPLETELY BEFORE TRYING TO OPERATE OR SERVICE THIS HEATER. IMPROPER USE OF THIS HEATER CAN CAUSE SERIOUS INJURY OR DEATH FROM FIRE, EXPLOSION AND CARBON MONOXIDE POISONING.

This is a direct-fired forced air construction heater for indoor construction use. Its intended use is primarily the temporary heating of buildings or structures under construction, alteration or repair. All the products of combustion generated by the heater are forced through the heater and released into the area being heated. This heater operates at approximately 99%+ combustion efficiency but still produces a small amount of carbon monoxide. Humans can tolerate small amounts of carbon monoxide for short periods. Carbon monoxide can build up in a heated space and failure to provide adequate ventilation could result in poisoning or death.

 **WARNING:** Not for use with duct work.

AIR QUALITY HAZARD

- Do not use this heater for heating human living quarters.
- Use of direct-fired heaters in the construction environment can result in exposure to levels of CO, CO₂, and NO₂ considered to be hazardous to health and potentially life threatening.
- Do not use in unventilated areas
- Know the signs of CO and CO₂ poisoning
 - Headaches, stinging eyes
 - Dizziness, disorientation
 - Difficulty breathing, feels of being suffocated
- Proper ventilation air exchange (OSHA 29 CFR 1926.57) to support combustion and maintain acceptable air quality shall be provided in accordance with OSHA 29 CFR Part 1926.154, ANSI A10.10 Safety Requirements for Temporary and Portable Space Heating Devices and Equipment used in the Construction Industry or the Natural Gas and Propane Installation Codes CSA B149.1
 - Periodically monitor levels of CO, CO₂ and NO₂ existing at the construction site—at the minimum at the start of the shift and after 4 hours.
 - Provide ventilation air exchange, either natural or mechanical, as required to maintain acceptable indoor air quality

Installation of this appliance at altitudes above 2000 ft (610 m) shall be in accordance with local codes, or in the absence of local codes, the National Fuel Gas Code, ANSI Z223.1/NFPA 54, or National Standard of Canada, Natural Gas and Propane Installation Code, CSA B149.1

USA 8-Hr Time weighted average
(OSHA 29 CFR 1926.55 App A)

CO 50 ppm
CO₂ 5000 ppm

NO₂

USA – Ceiling Limit
(Short Term Exposure Limit = 15 minutes)

CO
CO₂
NO₂ 5 ppm

Canada 8-hr time weighted average
WorkSafe BC OHS Guidelines Part 5.1
and Ontario Workplaces Reg 833

25 ppm

5000 ppm

3 ppm (Reg 833)

Canada STEL (15 minutes Reg 833/1 hour
WSBC) WorkSafe BC OHS Guidelines Part
5.1 and Ontario Workplaces Reg 833

100 ppm

15000 ppm (WSBC)
30000 ppm (Reg 833)

1.0 ppm (WorkSafeBC)
5.0 ppm (Reg 833)

- Ensure that the flow of combustion and ventilation air exchange cannot become obstructed.
- As the building 'tightens up' during the construction phases ventilation may need to be increased.

⚠ WARNING: Certified for use with DeWalt 20V or Milwaukee M18 Rechargeable battery packs. Refer to chart below a list of approved batteries.

Approved Battery Packs		
Size	Run Time	All Run times are approximate. Actual run times may vary. State of charge, battery temperature, and battery age will all affect actual run time. *Maximum initial battery voltage (measured without a workload) is 20 volts. Nominal voltage is 18.
2.0 Ah	Up to 3 Hours	
5.0 Ah	Up to 8 Hours	
8.0 Ah	Up to 13 Hours	

SPECIFICATIONS

Model No.	MODEL: LPFA60BDG			
INPUT RATING	36000 BTU/hr (low) - 60000 BTU/hr (high)			
TYPE OF GAS	PROPANE			
GAS SUPPLY PRESSURE TO REGULATOR MAXIMUM	BOTTLE PRESSURE			
MINIMUM (FOR PURPOSE OF INPUT ADJUSTMENT)	25 PSI / 172 KPa			
MANIFOLD PRESSURE	5 PSI			
GAS CONSUMPTION (Lb/Hr)	High-2.78 Low-1.39			
GAS CONSUMPTION (Kg/Hr)	High-1.26 Low-0.63			
ELECTRICAL INPUT	120 V, 60 Hz / 18 V DC			
AMPERAGE LOAD	120 V AC	0.174 amps		
	18 V DC*	0.61 amps		
IGNITION	ELECTRONIC SPARK			
SPARK GAP	4 mm (0.157")			
SIZE (LxWxH)	Leg Inserted	449mm (17.68")	409mm (16.10")	285mm (11.22")
	Leg Extended	466mm (18.35")	422mm (16.61")	285mm (11.22")
MIN OPERATING TEMPERATURE	0 ° F (-18 ° C)			
MIN STORAGE TEMPERATURE	0 ° F (-18 ° C)			

Note: *Maximum initial battery voltage (measured without a workload) is 20 volts.
Nominal voltage is 18.

GENERAL SAFETY INSTRUCTION

Accidents are always tragic especially because so many of them could have been prevented with little care and good judgment.

Below are some basic good practices, we hope you will follow for safe use of your heater.

IMPORTANT SAFETY INSTRUCTION

- Children should be supervised, when they are in the area.
- Always maintain proper clearance from combustible materials. Minimum clearance from combustibles: Side - 24" (61 cm); Top - 48" (121.9 cm); Front - 72" (183 cm). Floor - combustible. Not for use on finished floors.
- Heater must be placed on a level and stable surface.
- Never place anything including clothes or other flammable items on the heater.
- The appliance area shall be kept clear and free from combustible materials, gasoline and other flammable vapor and liquids.
- Do not modify or operate a heater which has been modified.
- Adequate clearance for accessibility and for combustion & ventilation air supply must be maintained at all times when the heater is operating.
- Service and repair should be done by a qualified service person. The heater should be inspected before each use and at least annually by a qualified person. More frequent cleaning may be required as necessary. Do not service while hot or operating.
- Never connect heater to an unregulated gas supply.
- The heater is shipped from the factory for LP(Propane) gas. This heater is for use with propane gas only, do not convert heater to any other gas. Installation must conform to local codes or, in the absence of local codes, with the standard for the Storage and Handling of Liquefied Petroleum Gases ANSI/NFPA 58 and the Natural Gas and Propane Installation Code CSA B149.1
- The minimum and maximum inlet pressures to the regulator from the gas tank are 25 psi minimum and bottle pressure, respectively. Use only the regulator & hose assembly provided with the heater. Inspect the regulator/hose assembly prior to each use of the heater. If there is excessive abrasion or wear, or hose is cut, replace with regulator/hose assembly listed on the parts list prior to using this heater.
- Gas supply connections should be checked using a 50/50 solution of liquid dish soap and never use a flame to check for gas leaks.
- The electrical connection & grounding must comply with National Electrical Code. ANSI/NFPA 70 or in Canada CSAC22.1, Canadian Electrical Code, Part 1. Use only a properly grounded three (3) prong receptacle.
- Do not restrict inlet or outlet by any means. The flow of combustion and ventilation air is not to be obstructed.
- This heater should not be directed toward any propane-gas container within 20 ft (6M). The heater must be located at least 6 ft. (1.83 m) in the U.S.; or 10 ft. (3 m) in Canada, from any propane gas container.
- The propane cylinder supply system must be arranged to provide for vapor withdrawal from the operating cylinder.
- This heater is not to be used with external thermostats, timers or other devices that control or alter electrical supply to the heater.
- For indoor use. Adequate ventilation shall be provided in accordance with OSHA 29 CFR 1926.154, Safety Requirements for Temporary and Portable Space Heating Devices and Equipment ANSI A10.10, ANSI 223.1 / NFPA 54, Liquefied Petroleum Gas Code, NFPA 58 or the National Gas and Propane Installation Code, CAN B149.1 as appropriate.
- The minimum clearances to combustible materials: Side - 24" (61 cm); Top - 48" (121.9 cm); Front - 72" (183 cm); Floor - combustible, must be maintained at all times.
- The hose assembly should be visually inspected prior to each use of the heater. If it is evident that there is excessive abrasion or wear, or the hose is cut, it must be replaced prior to the heater being put into operation.
- The replacement hose assembly shall be that specified by the manufacturer (Refer to parts list).
- The heater shall be installed such that it is not directly exposed to water spray, rain and/or dripping water.

⚠ WARNING: Motor and fan must be running before lighting, during operation and at shutdown, in order to prevent a flame-out condition which could result in personal injury or property damage.

PRODUCT FEATURES

- Portable & Stable
- Wind Resistant & Rain Protected
- Electronic Spark Ignition
- Safety Lockout Mechanism to Prevent Accidental Gas Leakage
- 100% Safety Shutoff System
- Continuous Adjustable Input Ratings

UNPACKING THE HEATER

1. Remove the heater from carton.
2. Remove all protective packing applied to heater for shipment.
3. Retain cartons and packaging material until unit is operated and found in good condition.
4. Check the heater for any shipping damage. If the heater shows any external or internal damage, promptly inform dealer/distributor/retailer where you purchased heater.

HOSE CONNECTION INSTRUCTIONS:

Tools required for assembly:
2 Adjustable Wrenches

Contents:
All Models: Unit, Manual,
Hose and Regulator Assembly

Regulator and Hose Connection:

See figure below.
Connect the hose tightly to the heater using a wrench while holding the fitting on the heater with another wrench.

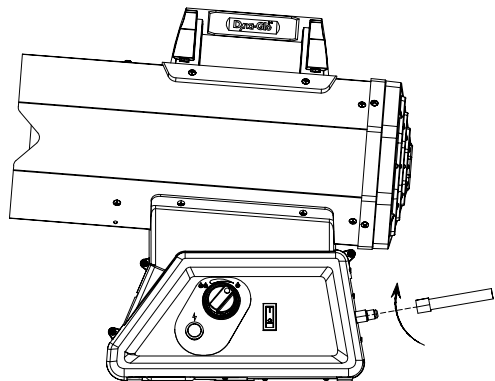

INFORMATION ON SIZE CAPACITY OF PROPANE GAS CYLINDERS:

The chart below shows the number and size of propane tanks needed to run this heater. *Less gas is vaporized at lower temperatures. You may need two or more 100 pound (45 kg) tanks or one larger tank in colder weather. (See the parts list for your model of heater to get the specified regulator assembly.)

Temperature (°F-°C) at tank	Number of Tanks
	30,000-60,000 BTU/h
Above 32°F (0°C)	1 - 20lb (9kg)
32°F (0°C)	1 - 20lb (9kg)
20°F (-7°C)	1 - 20lb (9kg)
10°F (-12°C)	1 - 20lb (9kg)
-10°F (-23°C)	2 - 20lb (9kg)
-20°F (-29°C)	1 - 100lb (45kg)

THE PROPANE (LP) GAS TANK MUST ALSO BE EQUIPPED WITH THE FOLLOWING:

- A collar to protect the Propane gas valve.
- A shutoff valve terminating a Propane gas cylinder valve outlet as specified in the
- American National Standards for Compressed Gas Cylinder Valve Outlets and Inlet Connections.
- A safety relief valve having direct communications with the vapor space of the tank.
- An arrangement of vapor withdrawal.

The propane (LP) gas pressure regulator and hose assembly supplied with this heater must be used without alteration.

The hose assembly shall be visually inspected prior to each use of the heater. If it is evident that there is excessive abrasion or wear, or the hose is cut, it must be replaced prior to the heater being put into operation. The replacement hose assembly shall be that specified by the manufacturer.

INSTALLATION TO THE PROPANE GAS TANK

IMPORTANT: You must use a propane gas supply cylinder that is compatible with the connection device provided with the hose and regulator.

FIG. 1

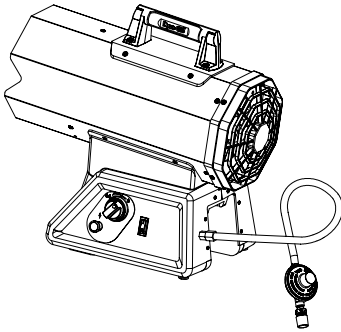

1. Provide propane supply system. Ensure that the valve on the cylinder is fully closed by turning the knob fully clockwise (↻). Ensure that the cylinder is fully upright for vapor withdrawal. (see size/capacity, page 7).
2. Connect hose to heater inlet. (See Figure 1). Tighten firmly using a wrench. You must use the regulator supplied with heater.
3. Connect fuel gas fitting hose/regulator assembly to propane tank(s). (See figure 2) Turn POL Fuel fitting counterclockwise into threads on tank. Tighten firmly using a wrench. Some models have a hand wheel that can be used to tighten the fitting. This hand wheel can be slid off of the nut so that a wrench can also be used to tighten the fitting. **IMPORTANT:** Position regulator so that hose leaving the regulator is in a horizontal position as shown in figure 2.
4. Open propane supply valve on propane tank(s) slowly. **NOTE:** If not opened

FIG. 2

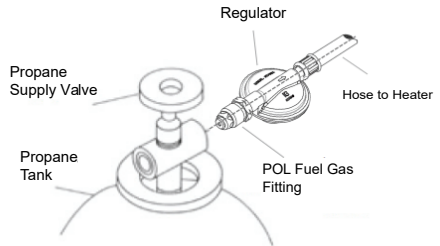

- slowly, excess flow device in regulator may stop gas flow. If this happens, close propane supply valve, wait one minute (or until you hear a click) and open again slowly.
5. Check all connections for leaks. Apply a 50/50 solution of liquid dish soap and water to gas joints. Bubbles forming show a leak that must be corrected.
 6. Close propane supply valve before attempting to repair connection.

⚠ WARNING: Purging and filling of LP gas tanks must be performed by personnel who has been thoroughly trained in accepted LP gas industry procedures. Failure to follow these instructions may result in explosion, fire, severe personal injury, or death.

REFILLING THE PROPANE GAS TANK

ALL NEW CYLINDERS MUST BE PURGED BEFORE THE FIRST FILLING.

- Turn heater gas valve knob and gas tank valve to OFF position.
- Propane tank valve equipped with the old style fitting has LEFT HANDED THREADS. Turn POL fitting CLOCKWISE to loosen. Protect POL fitting when disconnected from tank.
- Have tank filled by your local Propane gas supplier.
- Fasten full Propane tank and connect POL fitting to tank valve by turning COUNTERCLOCKWISE.
- With heater gas valve knob still in the OFF position, turn ON tank valve and check for leaks with soap solution.

BATTERY INSTALLATION AND REMOVAL INSTRUCTIONS

To install the battery align it with the guide rails on the Heater and push firmly until it clicks into position. To remove the Battery, depress the release Button and pull firmly outward.

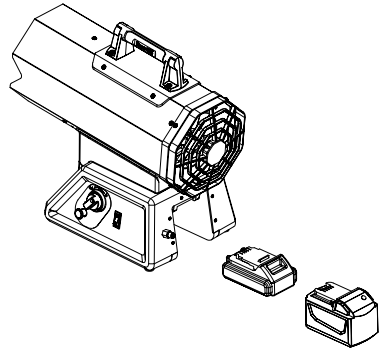

EXTENSION CORD ATTACHMENT

To operate the Heater with 120V AC power attach the female end of a 16 gauge, outdoor rated, three prong extension cord to the socket located at the rear of the Heater. Make sure the cord is fully inserted.

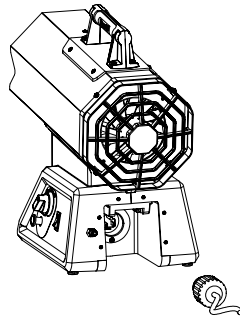

HEATER TILT ADJUSTMENT INSTRUCTIONS

The Heater has two tilt angles, LOW and HIGH as illustrated in Figure 3 and 3a. To move the Heater to either of these positions the TILT Buttons must be depressed simultaneously while the front leg is pulled/ pushed into position. A clicking sound indicates the front leg has been properly positioned.

FIG. 2

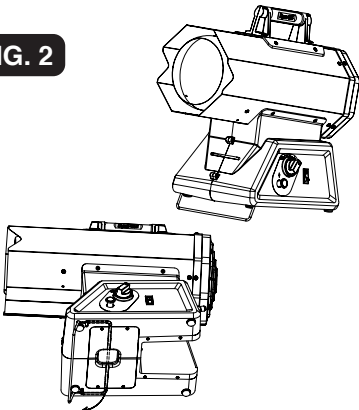

FIG. 3

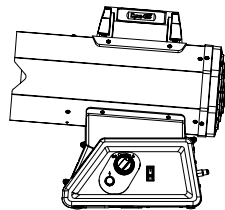
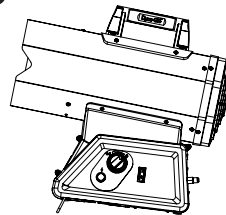

FIG. 3A



PROPANE SAFETY

Propane is safe to use when properly handled. Careless handling of the Propane gas tank could result in fire and/or an explosion. Therefore:

- Always keep tank/cylinder securely fastened in an upright position.
- Avoid tipping tank on its side when connected to a regulator since this may cause damage to diaphragm in regulator.
- Handle valves with care.
- Never connect an unregulated Propane tank to construction heater.
- Do not subject Propane tank to excessive heat.
- Tightly close the gas shutoff valve

- on the Propane tank after each use.
- The POL fitting must be protected when disconnected from the propane tank.
- Never store a Propane gas tank inside a building or in the vicinity of any gas burning appliance.

THE DISCONNECTED TANK MUST NEVER BE STORED IN A BUILDING, GARAGE OR ANY OTHER ENCLOSED AREA.

LEAK CHECKING



Check all gas connections with a soap solution to be sure they are tight and leak proof.



- The installation of your heater must meet all local codes and/or gas utility require-

ments or, in the absence of local codes, with the Storage and Handling of Liquefied Petroleum Gases, ANSI/ NFPA 58 and the Natural and Propane Installation Code, CSA B149.1.

LIGHTING INSTRUCTIONS



⚠WARNING: Motor and fan must be running before lighting, during operation and shutdown, in order to prevent a flame-out condition which could result in personal injury or property damage.

1. Connect power cord to a properly grounded three (3) prong 120V, 60Hz, single phase receptacle or insert DC battery as previously instructed.
2. Turn gas valve knob clockwise  to the minus sign “-” position.
3. Wait five (5) minutes to clear any gas. Then smell for gas. If you don't smell gas, go to next step
4. Turn gas supply ON by turning propane tank valve counterclockwise .

5. Toggle the ON/OFF switch to the ON “ I ” position. Keep the gas control knob at the minus sign “-” position.
6. Fully depress the ignition button  and hold until the electric spark lights the burner.
7. Keep the ignition button  pressed for at least 30 seconds after the burner is lit. After 30 seconds, release the ignition button.
8. If burner does not stay lit, repeat the lighting procedure.
9. When burner is lit, turn gas valve knob counterclockwise  to desired setting.

SHUTDOWN INSTRUCTIONS

⚠ WARNING: Motor and fan must be running before lighting, during operation and at shutdown, in order to prevent a flame-out condition which could result in personal injury or property damage.

1. Turn gas valve knob clockwise  to the minus sign “-” position.
2. Turn gas supply OFF by turning propane tank valve clockwise  to close.

3. Keep the heater running for 30 seconds to get the excess heat out before turning it OFF.
4. Toggle the ON/OFF switch to the OFF “O” position to turn off the fan motor
5. Disconnect the power cord once the heater has cooled to ambient temperature.

TEST FIRING HEATER

Test fire your construction heater, following the lighting instructions applicable to the gas control system employed. Leak test all

gas connections with soap solution. Soap bubbles indicate gas leakage. DO NOT use a match or flame to test for gas leaks.

STORAGE

Never store a Propane gas tank inside a building or in the vicinity of any gas or oil burning appliance. When the Propane tank is not disconnected from the construction heater, the gas tank and heater must be stored outdoors in a well ventilated area, out of the reach of children. If for any reason the heater is to be stored indoors, the tank must be disconnected and stored outdoors in a well ventilated area

out of reach of children, in accordance with the standard for the the Storage and Handling of Liquefied Petroleum Gases, ANSI / NFPA 58 and CSA B149.1, Natural Gas and Propane Installation Code. The plastic tank valve plug supplied with your tank must be tightly installed when the tank is disconnected from the heater.

MAINTENANCE INSTRUCTIONS

1. Turn unit off, allow heater to fully cool and disconnect propane hose before performing any maintenance functions. Remove the battery of unplug the unit from the 120 volt receptacle.
2. Keep unit clean and keep the inside of the tube housing debris free.
3. Have unit checked by a qualified technician at least once a year, preferably prior to the heating season.

REPLACEMENT PARTS

⚠ WARNING: Use only original replacement parts. This Heater must use design-specific parts. Do not substitute or use generic parts. Improper replacement parts could cause serious or fatal injuries. This will also protect your warranty coverage for parts replaced under warranty.

When calling, have ready:

- your name
- your address
- how heater was malfunctioning
- serial number of heater
- model number of heater
- replacement part number

Parts warranty and non-warranty: Contact authorized dealers of this product. If they can not supply original replacement part(s), either contact your nearest Parts Central or Technical Service Department at 1-877-447-4768.

TROUBLESHOOTING

PROBLEM	POSSIBLE CAUSE	CORRECTIVE ACTION
<p>Fan does not turn when electrical connection is made.</p>	<ol style="list-style-type: none"> 1. No electric power to heater. 2. Fan blade contacts inside of heater housing. 3. Fan motor defective. 	<ol style="list-style-type: none"> 1. Check current to electric outlet. If voltage is correct, check power cord and extension cord for damage. 2. Be sure that housing is not damaged. Make sure there are no obstructions to the fan. 3. Replace motor.
<p>Heater will not fire.</p>	<ol style="list-style-type: none"> 1. No spark at ignitor. 2. Improper spark gap. 3. Bad electrode. 4. Weak battery. 	<ol style="list-style-type: none"> 1. Check ignitor wire. Reattach or tighten if loose. Check spark module. Replace if necessary. 2. Set gap (see specifications for gap). 3. Replace spark electrode. 4. Charge battery.
<p>Heater quits while running.</p>	<ol style="list-style-type: none"> 1. Internal temperature too high causing limit switch to shut down operation. 2. Damaged Control Valve. 3. Dust or debris build-up inside of heater. 4. Battery voltage drops below 16.5V. 	<ol style="list-style-type: none"> 1. If the heater's output is restricted, internal temperature becomes too high. Move heater away from any obstructions. 2. Replace Control Valve. 3. Clean inside of heater. 4. Charge battery.

Always be sure to follow proper maintenance procedures, by cleaning the heater once per month during regular usage, and check spark gap at least once per season.

WIRING DIAGRAMS

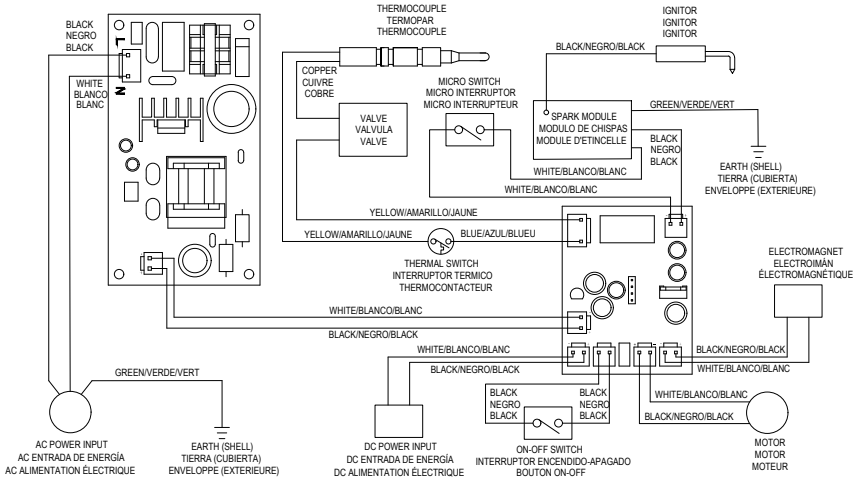

REPLACEMENT PARTS LIST

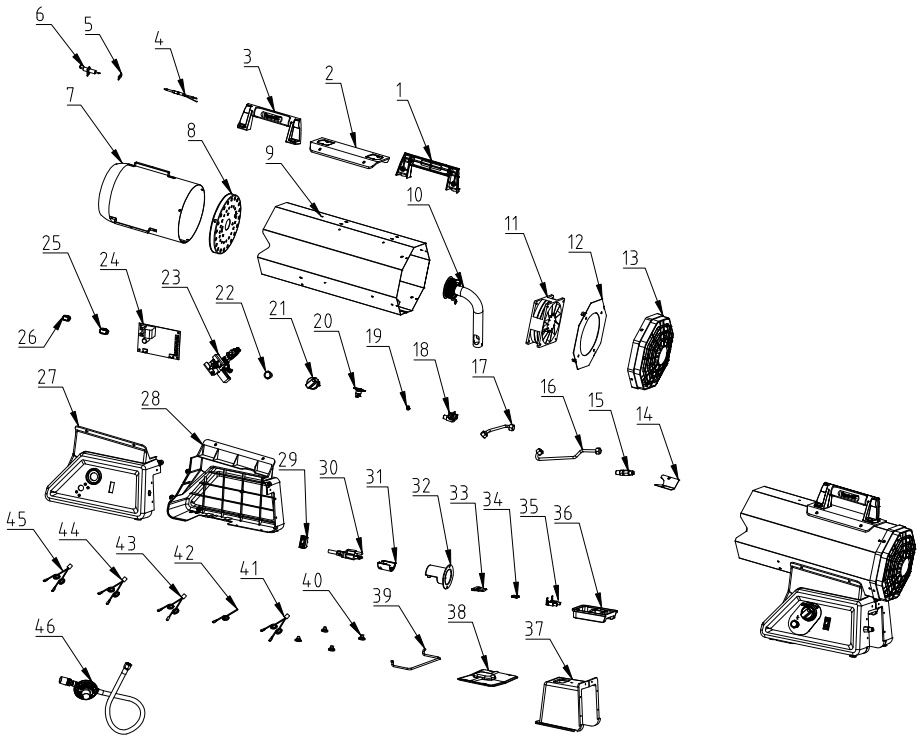

REPLACEMENT PARTS LIST

MODEL: LPFA60BDG

ARTICLE #	DESCRIPTION	PART NUMBER	QTY
1	Handle Left	FA60DG-DC-05	1
2	Handle Seat	FA60QG-DC-07	1
3	Handle Right	FA60DG-DC-06	1
4	Thermocouple	FA60Q-16	1
5	Thermocouple Fixture	LPC80-06	1
6	Spark Plug	FA60-04	1
7	Inner Shell	FA60QG-DC-04	1
8	Flame Cup	FA60Q-05	1
9	Outer Shell	FA60QG-DC-01	1
10	Burner Assembly	FA60Q-06	1
11	Quiet Motor	FA60Q-DC-11	1
12	Motor Bracket	FA60QG-DC-09	1
13	Wire Guard	FA60QG-DC-08	1
14	Venturi Plate	FA60QG-DC-10	1
15	Gas Inlet Connector	FA60Q-DC-12	1
16	Gas Inlet Tubing	FA60QG-DC-21	1
17	Gas Outlet Tubing	FA60QG-DC-22	1
18	Nozzle Holder	GP126-SMT-01	1
19	Nozzle	FA60Q-18	1
20	Thermal Switch	FA60-02	1
21	Control Knob	FA60Q-12	1
22	Ignition Button	FA60Q-13	1
23	Valve	GZ85F60QGDC	1
24	PCB	FA60QG-DC-16	1
25	Protective Case	SB-19	1
26	Protective Case	SB-16	1
27	Base Right	FA60QG-DC-03	1
28	Base Left	FA60QG-DC-02	1
29	On-Off Switch	FA60Q-DC-20	1
30	Power Cord	FA60QG-DC-19	1
31	Power Cord Cover	FA60QG-DC-15	1
32	Power Cord Seat	FA60QG-DC-14	1
33	Terminal Fixture	FA60QG-DC-13-03	1
34	Spring	GS16-07	1
35	Battery Terminal	FA60QG-DC-13-02	1
36	Battery Seat	FA60QG-DC-13-01	1
37	Battery Housing	FA60QG-DC-12	1
38	Base Lower	FA60QG-DC-11	1
39	Bracket	FA60QG-DC-17	1
40	Support Leg	HA1360-23	4
41	Microswitch Connection Wire	FA60QG-DC-18	1
42	Ignition Wire	FA60Q-DC-34	1
43	Wire	FA60Q-15	1
44	Switch Connection Wire	FA60Q-DC-25	1
45	DC Connection Wire	FA60QG-DC-20	1
46	Regulator & Hose Assembly	GR-108N-01SMT	1

WARRANTY REGISTRATION

IMPORTANT: We urge you to fill out your warranty registration within fourteen (14) days of date of purchase. You can register your warranty on the internet at www.ghpgroupinc.com. Complete the entire serial number.



GHP Group, Inc.
6440 W Howard St
Niles, IL 60714-3302

Tel: (877) 447-4768
www.ghpgroupinc.com

Questions, problems, missing parts? Before returning to your retailer, call our customer service department at 877-447-4768 8:00 a.m. – 4:30 pm CST, Monday – Friday



GHP Group, Inc.
6440 W Howard St
Niles, IL 60714-3302

Tel: (877) 447-4768
www.ghpgroupinc.com