

BENCHMARK™ MC

GAS CHAINSAW 18IN 45CC OWNER'S MANUAL

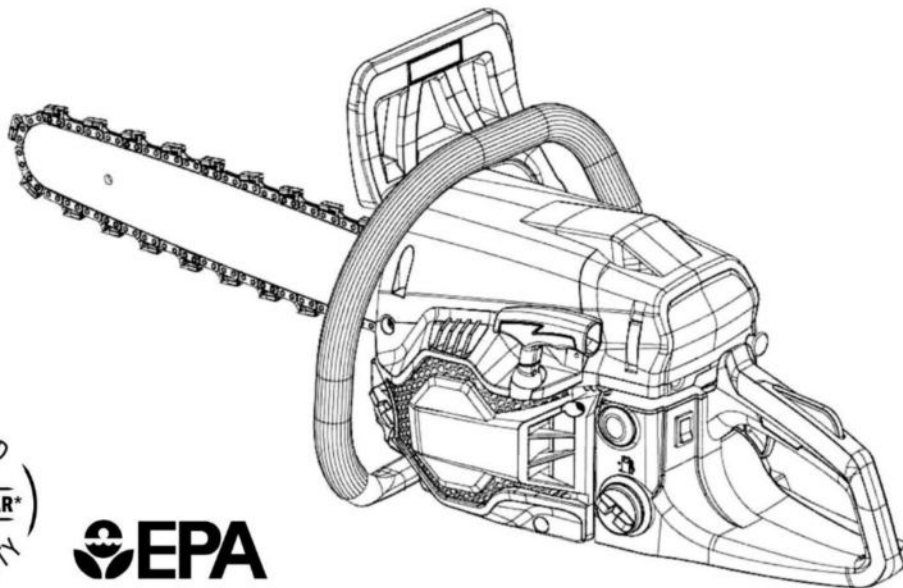

**READ ALL INSTRUCTIONS BEFORE FIRST USE.
KEEP THIS MANUAL FOR FUTURE REFERENCE.
KEEP AWAY FROM CHILDREN.**



**WEAR CSA APPROVED
EYE PROTECTION**



**WEAR EAR
PROTECTION**



**WEAR A
FACE MASK**

PRODUCT SPECIFICATIONS

18IN 45CC CHAINSAW	
Model	5240-186
Engine Displacement	45.02 cm ³
Engine Type	Single Cylinder 2-stroke
Cooling System	Forced air cooled
Fuel Type	87+ octane stabilizer-treated unleaded gasoline containing no more than 10% ethanol (E10) mixed with 2-Stroke oil (see below)
Fuel Capacity	600ml (20.3 fl. oz.)
Oil Type	2-Stroke oil must meet either JASO M345 FD or ISO-L-EGD requirements for air-cooled engines, synthetic
Gasoline / Oil Ratio	50:1 gas-to-oil ratio: 20 ml oil per 1 liter gasoline (2.56 oz oil per gal of gasoline)
Bore x Stroke	43 mm x 31 mm
Compression Ratio	7.5:1
Spark Plug Type	Champion® RCJ7Y Bosch® L8RTF NGK® BPMR7A
Gap	0.508 mm (0.02 inch)
Speed Idle	3000±400RPM
Saw Chain Length	18 inches (45.72 cm)
Pitch	0.325 inch
Gauge	0.058 inch
Saw Chain Model	Oregon 21BPX072X AdvanceCut™
Guide Bar Length	18 inches (45.72 cm)
Guide bar Model	Oregon 188PXBK095 AdvanceCut™
Lubrication Type	Bar and chain oil
Lubrication Capacity	260 ml (8.8 fl. oz.)

TABLE OF CONTENTS

Product Specifications.....2

Table of Contents.....3

Important Safety Instructions.....4

General Warnings.....6

Symbols.....8

Set Up.....9

Controls and Operations.....14

Maintenance.....24

Troubleshooting.....31

Exploded Views And Parts.....34

Warranty.....31

IMPORTANT SAFETY INSTRUCTIONS

WARNING DEFINITIONS



This is the safety alert symbol. It is used to alert you to potential personal injury hazards. Obey all safety messages that follow this symbol to avoid possible injury or death.

▲ DANGER!

Indicates a hazardous situation which, if not avoided, will result in death or serious injury.

▲ WARNING!

Indicates a hazardous situation which, if not avoided, could result in death or serious injury.

▲ CAUTION!

Indicates a hazardous situation which, if not avoided, could result in minor or moderate injury.

NOTE

Addresses practices not related to personal injury.



SAVE THESE INSTRUCTIONS

This manual contains important instructions that should be followed during setup, operation, and maintenance of the chainsaw.

SET UP PRECAUTIONS

1. Gasoline fuel and fumes are flammable, and potentially explosive. Use proper fuel storage and handling procedures. Do not store fuel or other flammable materials nearby.
2. Have multiple ABC class fire extinguishers nearby.
3. Operation of this equipment may create sparks that can start fires around dry vegetation. A spark arrestor may be required. The operator should contact local fire agencies for laws or regulations relating to fire prevention requirements.
4. Set up and use only on a flat, level, well-ventilated surface.
5. Wear ANSI-approved safety goggles, heavy-duty work gloves, and dust mask/respirator during use.
6. Use only lubricants and fuel recommended in the Specifications chart of this manual.

OPERATING PRECAUTIONS

1. Chainsaws shall be used in accordance with the operating instructions and safety precautions listed in the operator's manual(s). It shall be the responsibility of the owner to see that such instructions and precautions are given to every operator who uses the saw.
2. Keep children away from the equipment, especially while it is in use.
3. Keep all spectators at least six feet from the Engine during operation.

4. Fire Hazard! Do not fill the fuel tank while the engine is running. Do not operate if gasoline has been spilled. Clean spilled gasoline before starting engine. Do not operate near pilot light or open flame.
5. Do not touch the engine during use. Allow engine to cool down after use.
6. Never store fuel or other flammable materials near the engine.
7. Secure the equipment on transport vehicles to prevent it from rolling, slipping, and tilting.
8. Do not leave the equipment unattended when it is running. Turn off the equipment (and remove safety keys, if available) before leaving the work area.
9. The equipment can produce high noise levels. Prolonged exposure to noise levels above 85 dBA is hazardous to hearing. Wear ear protection when operating or when working nearby while it is operating.
10. Use safety footwear; snug-fitting clothing; protective gloves; eye, hearing, and head protection devices.
11. People with pacemakers should consult their physician(s) before use. Electromagnetic fields in close proximity to a heart pacemaker could cause pacemaker interference or pacemaker failure. Caution is necessary when near the engine's magneto or recoil starter.
12. Use only accessories that are recommended by the manufacturer. Accessories that may be suitable for one piece of equipment may become hazardous when used on another piece of equipment.
13. Do not operate in explosive atmospheres, such as in the presence of flammable liquids, gases, or dust. Gasoline-powered engines may ignite the dust or the fumes.
14. Stay alert, watch what you are doing and use common sense when operating this piece of equipment. Do not use while tired or under the influence of drugs, alcohol, or medication.
15. Do not overreach. Keep proper footing and balance at all times. This enables better control of the equipment in unexpected situations.
16. Use this equipment with both hands only. A chainsaw is intended for two-handed use. Do not operate a chainsaw with one hand! Serious injury to the operator, helpers, bystanders, or any combination of these people may result from one-handed operation.
17. A chainsaw is intended for two-handed use.
18. Dress properly. Do not wear loose clothing or jewelry. Keep hair, clothing, and gloves away from moving parts. Loose clothes, jewelry or long hair can be caught in moving parts.
19. Parts, especially exhaust system components, get very hot during use. Stay clear of the hot parts.
20. Do not cover the equipment during operation.
21. Keep the equipment, engine, and surrounding area clean at all times.
22. Do not smoke, or allow sparks, flames, or other sources of ignition around the equipment, especially when refueling.
23. Use the equipment, accessories, etc., in accordance with these instructions and in the manner intended for the particular type of equipment, taking into account the working conditions and the work to be performed. Use of the equipment for operations different from those intended could result in a hazardous situation.
24. Do not operate the equipment with known leaks in the engine's fuel system.

25. When spills of fuel or oil occur, they must be cleaned up immediately. Dispose of fluids and cleaning materials as per any local, state, or federal codes and regulations. Store oil rags in a bottom-ventilated, covered, metal container.
26. Keep hands and feet away from moving parts.
27. Before use, check for misalignment or binding of moving parts, breakage of parts, and any other condition that may affect the equipment's operation. If damaged, have the equipment serviced before use. Many accidents are caused by poorly maintained equipment.
28. Use the correct equipment for the application. Do not modify the equipment and do not use the equipment for a purpose for which it is not intended.
29. Never operate a chainsaw while you are fatigued, ill, upset, under the influence of medication that may make you drowsy, or if you are in the influence of alcohol or drugs.
30. Use safety footwear; snug-fitting clothing; protective gloves; and eye, hearing, and head protection devices. Wear leg protection such as work pants or chaps.
31. Use caution when handling fuel. Mix and pour fuel outdoors where there are no sparks and flames. Slowly remove the fuel cap only after stopping the engine and allowing the chainsaw to cool. Do not smoke while fueling or mixing fuel. Move the chainsaw at least 10 feet (3 m) from the fueling point before starting the engine.
32. Do not allow other persons to be near the chainsaw when starting or cutting with the chainsaw.
33. Keep bystanders and animals out of the work area.
34. Do not start cutting until you have a clear work area, secure footing, and a planned retreat path from the falling tree.
35. Keep all parts of your body away from the saw chain when the engine is running.
36. Before you start the engine, make sure that the saw chain is not contacting anything.
37. Carry the chainsaw with the engine stopped, the guide bar and saw chain to the rear, and the muffler away from your body.
38. Do not operate a chainsaw that is damaged, improperly adjusted, or not completely and securely assembled. Be sure that the saw chain stops moving when the throttle control trigger is released.
39. Shut off the engine before setting the chainsaw down.
40. Use extreme caution when cutting small-size brush and saplings because slender material may catch the saw chain and be whipped toward you or pull you off balance.
41. When cutting a limb that is under tension, be alert for spring back so that you will not be struck when the tension in the wood fibers is released.
42. Keep the handles dry, clean, and free of oil or fuel mixture.
43. Operate the chainsaw only in well-ventilated areas.
44. Do not operate a chainsaw in a tree unless you have been specifically trained to do so.
45. All chainsaw service, other than the items listed in the operator's manual(s) maintenance instructions, should be performed by competent chainsaw service personnel. (For example, if improper tools are used to remove the flywheel or if an improper tool is used to hold the flywheel in order to remove the clutch, structural damage to the flywheel could occur and subsequently could cause the flywheel to burst.)
46. Allow the chainsaw to cool before performing maintenance or adjustments.
47. When transporting your chainsaw, use the appropriate guide-bar cover.

48. This machine generates toxic exhaust fumes such as carbon monoxide, and others may be colorless and odorless. To reduce the risk of serious injury/illness from inhalation, never run the machine indoors or in a poorly ventilated location.
49. Do not let familiarity gained from frequent use allow you to become complacent and ignore tool safety principles. A careless action can cause severe injury within a fraction of a second.

GENERAL WARNINGS

CHAINSAW SAFETY WARNINGS

1. **Keep all parts of the body away from the saw chain when the chainsaw is operating. Before you start the chainsaw, make sure the saw chain is not contacting anything.** A moment of inattention while operating chainsaws may cause entanglement of your clothing or body with the saw chain.
2. **Always hold the chainsaw with your right hand on the rear handle and your left hand on the front handle.** Holding the chainsaw with a reversed hand configuration increases the risk of personal injury and should never be done.
3. **Hold the power tool by insulated gripping surfaces only, because the saw chain may contact hidden wiring.** Saw chains contacting a “live” wire may make exposed metal parts of the power tool “live” and could give the operator an electric shock.
4. **Wear safety glasses and hearing protection. Further protective equipment for the head, hands, legs, and feet is recommended.** Adequate protective clothing will reduce personal injury by flying debris or accidental contact with the saw chain.
5. **Do not operate a chainsaw in a tree.** The operation of a chainsaw while up in a tree may result in personal injury.
6. **Do not allow other people to be near the chainsaw when starting or cutting with the chainsaw.** Keep bystanders and animals out of the work area. Do not start cutting until you have a clear work area, secure footing, and a planned retreat path from the falling tree.
7. **When cutting a limb that is under tension be alert for spring back.** When the tension in the wood fibers is released the spring loaded limb may strike the operator and/or throw the chainsaw out of control.
8. **Use extreme caution when cutting brush and saplings.** The slender material may catch the saw chain and be whipped toward you or pull you off balance.
9. **Carry the chainsaw by the front handle with the engine stopped, the guide bar and saw chain to the rear, and the muffler away from your body. When transporting or storing the chainsaw always fit the guide bar cover over the saw’s bar and chain.** Proper handling of the chainsaw will reduce the likelihood of accidental contact with the moving saw chain.
10. **Follow instructions for lubricating, chain tensioning and changing accessories.** Improperly tensioned or lubricated chain may either break or increase the chance for kickback.
11. **Keep handles dry, clean, and free from oil and grease.** Greasy, oily handles are slippery causing loss of control.
12. **Cut wood only. Do not use chainsaw for purposes not intended. For example: do not use chainsaw for cutting plastic, masonry, or non-wood building materials.** Use of the chainsaw for operations different than intended could result in a hazardous situation.

⚠ WARNING!   Kickback may occur when the nose or tip of the guide bar touches an object, or when the wood closes in and pinches the saw chain in the cut. (See Fig 1)

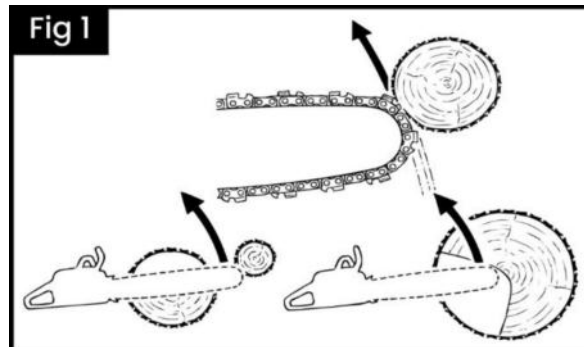

13. **Tip contact in some cases may cause a lightning-fast reverse reaction, kicking the guide bar up and back toward the operator.** Pinching the saw chain along the top of the guide bar may push the guide bar rapidly back toward the operator. Either of these reactions may cause you to lose control of the saw, which could result in a serious personal injury. Do not rely exclusively upon the safety devices built into your saw.

As a chainsaw user, you should take several steps to keep your cutting jobs free from accident or injury.

- With a basic understanding of kickback, you can reduce or eliminate the element of surprise. Sudden surprise contributes to accidents.
- Keep a good firm grip on the saw with both hands, the right hand on the rear handle and the left hand on the front handle, when the engine is running. Use a firm grip with thumbs and fingers encircling the chainsaw handles. A firm grip will help reduce kickback and maintain control of the saw. Don't let go.
- Make sure that the area in which you are cutting is free from obstructions. Do not let the nose of the guide bar contact a log, branch, or any other obstruction that could be hit while you are operating the saw.
- Cut at high engine speeds.
- Do not overreach or cut above shoulder height.
- Follow the manufacturer's sharpening and maintenance instructions for the saw chain.
- Only use replacement bars and chains specified by the manufacturer or the equivalent. Decreasing the depth gauge height can lead to increased kickback.

14. **Maintain labels and nameplates on the tool.** These carry important safety information. If unreadable or missing, contact the manufacturer for a replacement.

15. **Do not leave the tool unattended when it is running.** Turn off the tool before leaving the work area.

16. **This product is not a toy.** Keep it out of reach of children.















17. **People with pacemakers should consult their physician(s) before use.** Electromagnetic fields in close proximity to heart pacemaker could cause pacemaker interference or pacemaker failure.





18. **The warnings, precautions, and instructions discussed in this instruction manual cannot cover all possible conditions and situations that may occur.** It must be understood by the operator that common sense and caution are factors which cannot be built into this product but must be supplied by the operator.

 **SAVE THESE INSTRUCTIONS**

This manual contains important instructions that should be followed during setup, operation, and maintenance of the chainsaw.

SYMBOLS



SYMBOL	SIGNIFICATION
	WARNING: Read and follow all safety precautions in the operator's manual(s). Failure to follow instructions could result in serious personal injury.
 	WARNING: Risk of Loss of Control. Do not operate the chainsaw with only one hand.
 	WARNING: Risk of Loss of Control. Always use two hands when operating the chainsaw.
 	WARNING: Saw Chain Orientation. Cutters must face in direction of the rotation.
 	WARNING: Risk of Kickback. Contact of the guide bar tip with any object must be avoided.
	Read the manual before set-up and / or use of the chainsaw.
	Appropriate ear, eye, and head protection must be worn.
	Always wear safety and anti-vibration (AV) gloves when operating the chainsaw.
	Indicates saw chain orientation concerns. Cutters must face in direction of rotation.
	Indicates the port to refuel the "MIXED GASOLINE".
	Indicates the operation of the engine switch. Flip the switch to the "O" position to stop the engine immediately. "O" and "I" are shown on switch button.

SYMBOL	SIGNIFICATION
	Indicates the operation of the engine switch. Flip the switch to the "O" position to stop the engine immediately.
	Indicates the port to refill the saw chain oil.
	Indicates the adjustment of the oil flow. Turn the screw with a screwdriver counter-clockwise and the saw chain oil flows more. Turn the screw clockwise and the saw chain oil flows less.
	Indicates the operation of the choke knob. Pull the choke knob Out closes the choke. Push the choke knob In opens the choke.
	The screw under the "H" stamp indicates The High-speed mixture adjustment screw. The screw under the "L" stamp indicates The Low-speed mixture adjustment screw. The screw under the "T" stamp indicates The Idle-speed mixture adjustment screw.

SET UP

 Read the **ENTIRE IMPORTANT SAFETY INFORMATION** section at the beginning of this manual including all text under subheadings therein before setup or use of this product.

⚠ WARNING! TO PREVENT SERIOUS INJURY:
Operate only with proper spark arrestor installed.

⚠ WARNING!  
Operation of this equipment may create sparks that can start fires around dry vegetation. A spark arrestor may be required.
The operator should contact local fire agencies for laws or regulations relating to fire prevention requirements.

TO PREVENT SERIOUS INJURY FROM ACCIDENTAL STARTING: Make sure that the Engine is switched OFF, wait for the Engine to cool, and unplug the spark plug wire before performing any procedure in this section.

At high altitudes, the engine's carburetor, governor (if so equipped), and any other parts that control the fuel-air ratio will need to be adjusted by a qualified mechanic to allow efficient high-altitude use and to prevent damage to the engine and any other devices used with this product.

COMPONENTS AND CONTROLS

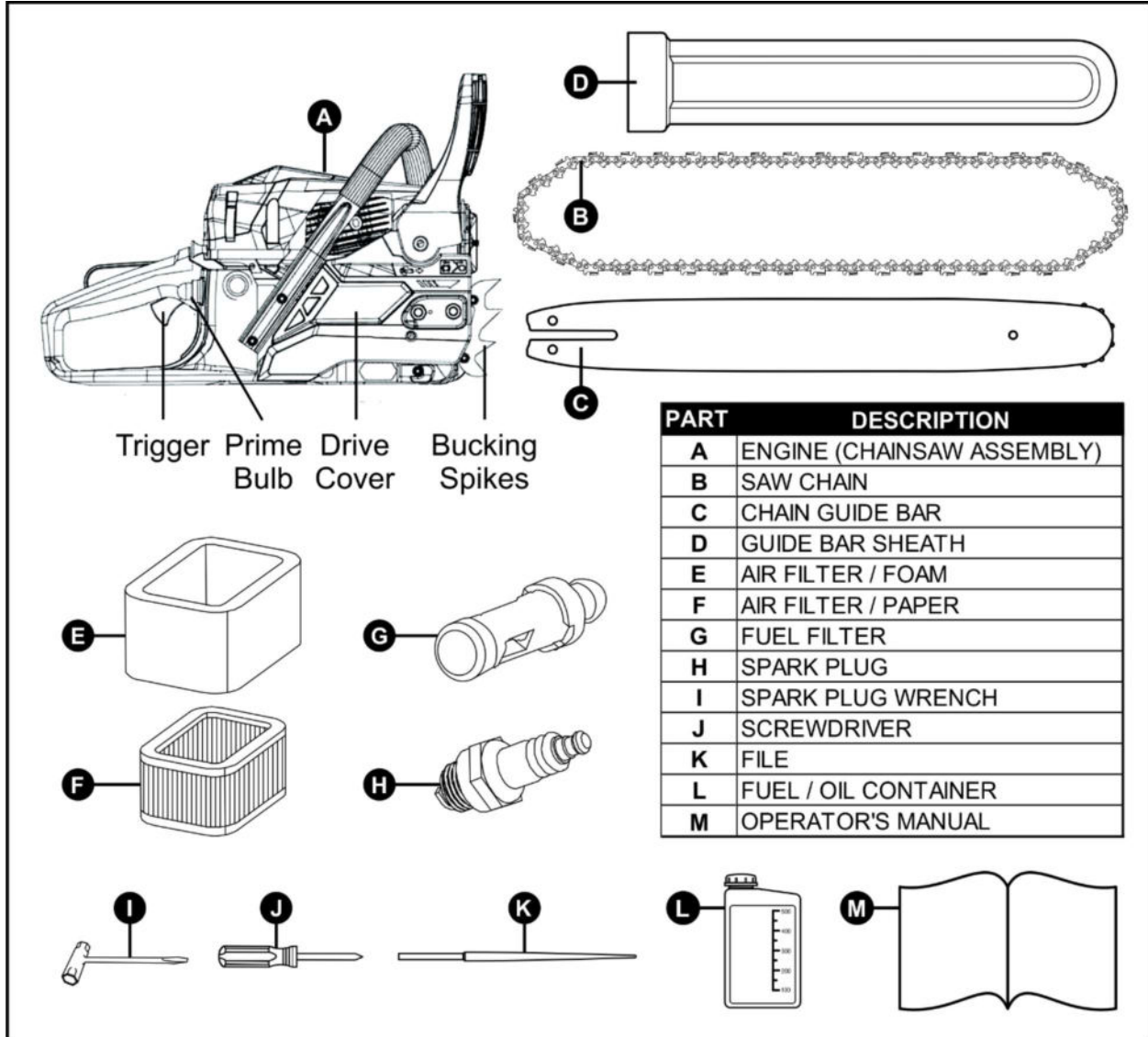

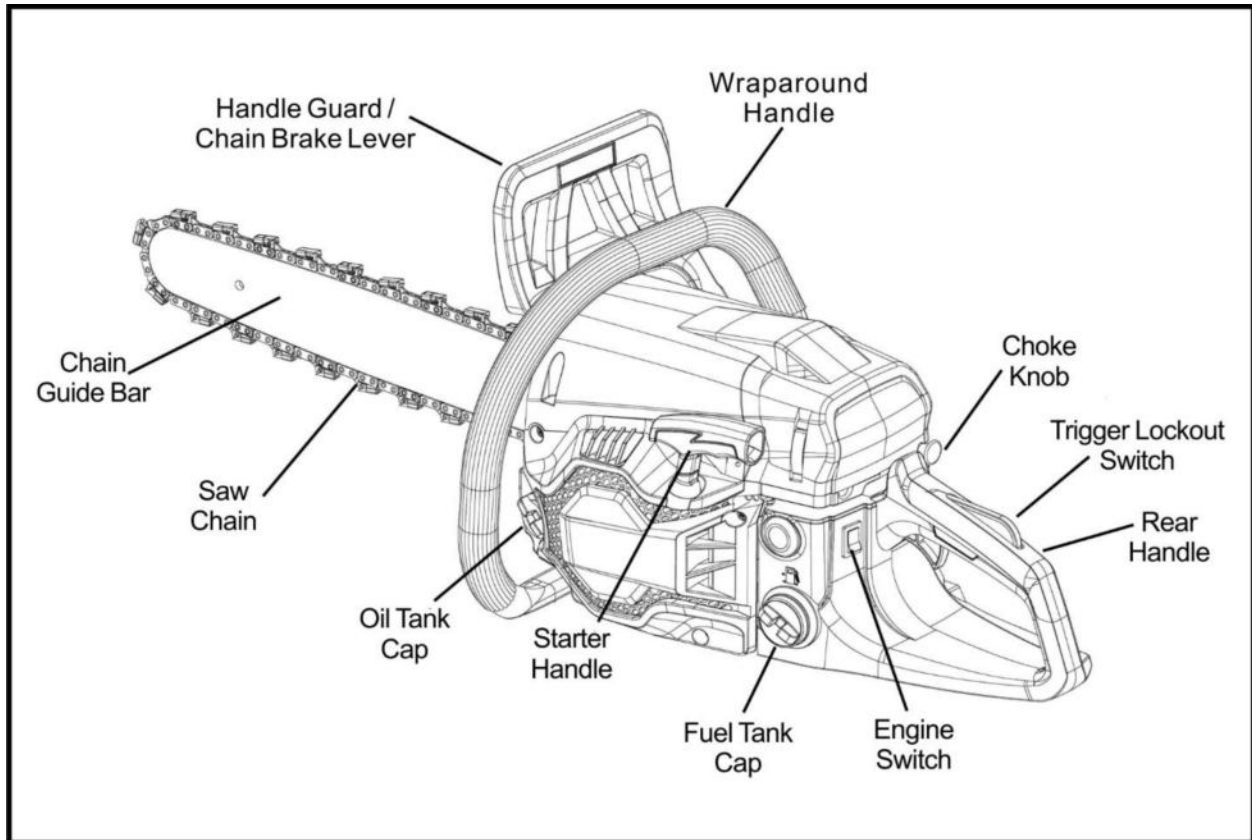

GUIDE BAR AND SAW CHAIN INSTALLATION AND ADJUSTMENT

⚠ WARNING! TO PREVENT SERIOUS INJURY FROM ACCIDENTAL OPERATION: Make sure that the Engine is switched OFF, wait for the Engine to cool, and unplug the spark plug wire before performing any procedure in this section.

NOTE New Saw Chains often need to be tensioned several times during first use. Check a new Saw Chain's tension often when first using.

Follow the directions in the following sections for installing the Guide Bar and Saw Chain, for checking and adjusting Saw Chain tension, and for replacing the Saw Chain when necessary.

GUIDE BAR & SAW CHAIN, INSTALLATION & REPLACEMENT

1. Pull the Hand Guard / Chain Brake Lever back toward the rear to make sure the chain brake is not on.
2. Loosen and remove the Drive Cover Nuts, then remove the Drive Cover from the Saw.
3. Place the Saw Chain over the Guide Bar. The cutters of the Saw Chain must face away from the Chainsaw along the top edge of the Guide Bar. Fit the Drive Links into the groove around the Guide Bar. Refer to Figure 2.
4. Place the slotted end of the Chain Guide Bar over the Guide Bar Bolts and place the Saw Chain over the Drive Sprocket. Refer to Figure 3.
5. Check again that the Saw Chain cutters are aligned properly, and the Saw Chain Drive Links are seated completely in the slot of the Guide Bar. The cutters of the Saw Chain must face away from the Chainsaw along the top edge of the Guide Bar. Refer to Figure 4.
6. Replace the Drive Cover, making sure the Chain Tension Pin on the Cover is inserted into the lower hole on the Guide Bar as shown in Figure 3. Replace the Drive Cover Nuts and tighten so that the Cover is snug, but not tight. Tension the Saw Chain following the steps in Checking Saw Chain Tension and Adjusting Saw Chain Tension that follow.

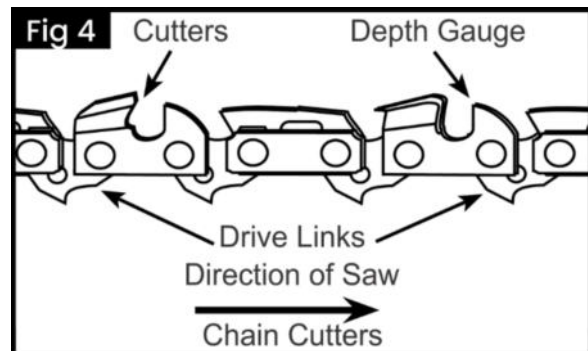
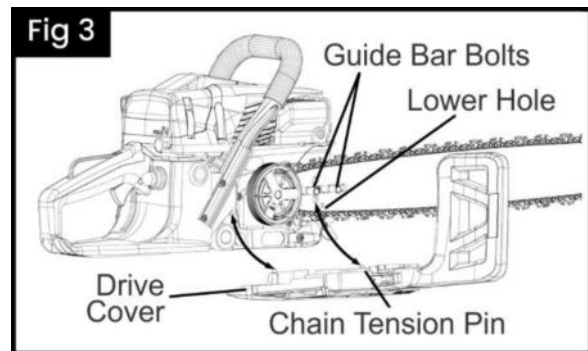
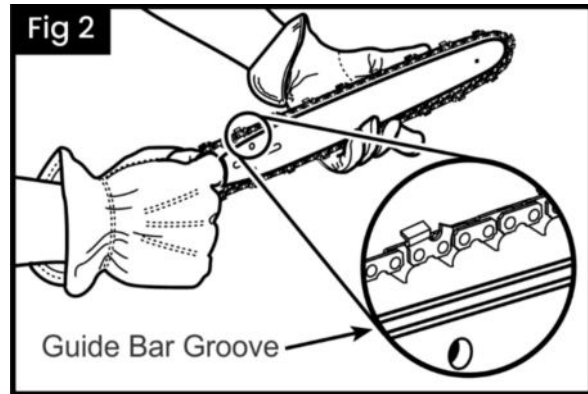

CHECKING SAW CHAIN TENSION

1. Before using, check the Saw Chain tension.
2. While wearing heavy-duty gloves, use your index finger and thumb to carefully grab the Saw Chain in the middle section under the Chain Guide Bar.
3. Pull the Saw Chain away from the Guide Bar.
4. The Saw Chain should snap back against the Guide Bar. The Chain should fit snugly in the groove of the Chain Guide Bar, yet you should still be able to slide the chain along the Chain Guide Bar by hand.
5. There should be no sagging between the Guide Bar and Saw Chain on the underside of the Guide Bar.

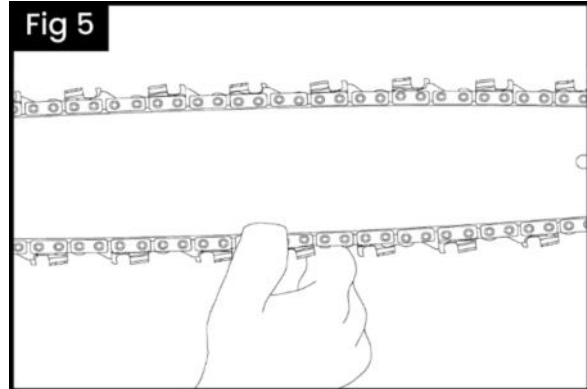

ADJUSTING SAW CHAIN TENSION

1. Loosen the Drive Cover Nuts on the Drive Cover. It is not necessary to remove the Drive Cover to adjust chain tension.
2. Turn the Chain Tension Screw clockwise to increase chain tension and counterclockwise to decrease tension. Refer to Figure 6A
3. Tighten the Drive Cover Nuts on the Drive Cover while holding the Chain Guide Bar up. Refer to Figure 6B
4. Check the Saw Chain tension again following sets 2 through 5 under Checking Saw Chain Tension listed above. If needed, repeat the adjusting steps to achieve the correct tension.

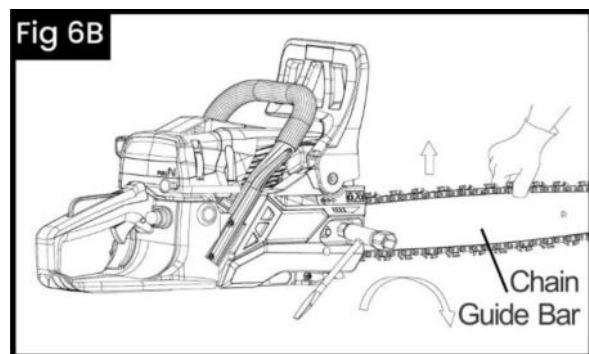
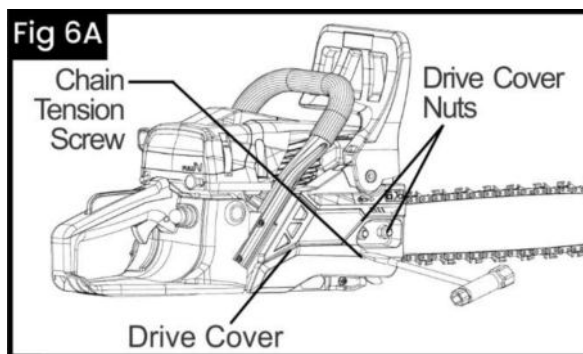

CONTROLS AND OPERATIONS



Read the **ENTIRE IMPORTANT SAFETY INFORMATION** section at the beginning of this manual including all text under subheadings therein before setup or use of this product.

CHECKING SAW CHAIN TENSION

Inspect engine and equipment looking for damaged, loose, and missing parts before setup and starting. If any problems are found, do not use the equipment until fixed properly.

CHECKING AND FILLING FUEL

⚠ WARNING!



TO PREVENT SERIOUS INJURY FROM FIRE:

Fill the fuel tank in a well-ventilated area away from ignition sources. If the engine is hot from use, shut the engine off and wait for it to cool before adding fuel. Do not smoke.

1. Clean the Fuel Tank Cap and the area around it.
2. Unscrew and remove the Fuel Tank Cap.

NOTE

Do not use gasoline containing more than 10% ethanol (E10). Do not use E85 ethanol. Add fuel stabilizer to the gasoline or the Warranty is VOID.

NOTE

Do not use gasoline that has been stored in a metal fuel container or a dirty fuel container. It can cause particles to enter the carburetor, affecting engine performance and/or causing damage.

⚠ IMPORTANT!

Your Warranty is VOID if the engine's Fuel Tank is not filled with the proper mixture (40:1) of unleaded gasoline and 2-cycle oil before each use. 2-Stroke oil (conventional, mineral-based, synthetic) must meet either JASO M345 FD or ISO-L-EGD requirements for air-cooled engines. Before each use, check the fuel level. Do not run the engine with an improper unleaded gasoline / 2-cycle oil mixture. Running the engine with an improper mixture WILL permanently damage the engine.

3. To obtain the proper gasoline and 2-cycle oil mixture, mix 50:1 gas-to-oil ratio: 20 ml oil per 1 liter gasoline (2.56 oz oil per 1 gallon of gasoline) into an approved container. Then gently agitate the container to thoroughly mix the gasoline / 2-cycle oil.

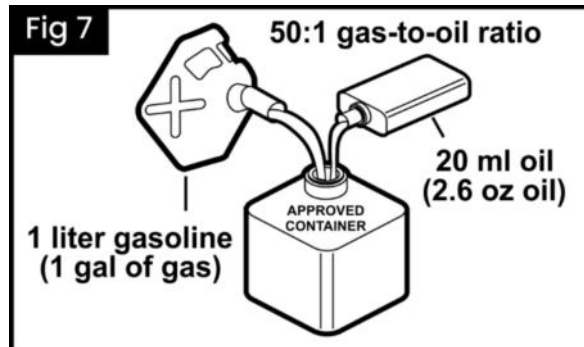

4. If needed, fill the Fuel Tank to about 1 inch under the fill neck of the Fuel Tank with the pre-mixed unleaded gasoline / 2-cycle oil mixture.
5. Then close the fuel tank with the fuel tank cap.
6. Wipe up any spilled fuel and allow excess to evaporate before starting the engine. To prevent FIRE, do not start the engine while the smell of fuel hangs in the air.
7. Use caution when handling fuel. Move the chainsaw at least 3 meters (10 feet) from the fueling point before starting the engine.

CHECKING CUTTING OIL SUPPLY

▲ IMPORTANT! NEVER USE THE MACHINE WITHOUT LUBRICATION! ALWAYS CHECK CHAIN LUBRICATION AND THE OIL LEVEL IN THE TANK BEFORE STARTING WORK.

For a chainsaw to cut safely and effectively, its chain must have the proper lubrication. If the chain is too dry it can rob the engine of power due to increased friction. If the chain is too dry it runs the risk of breaking and causing personal injury.

1. After starting the engine run the chainsaw at medium speed and see if the chain oil is scattered off as shown in Figure A.

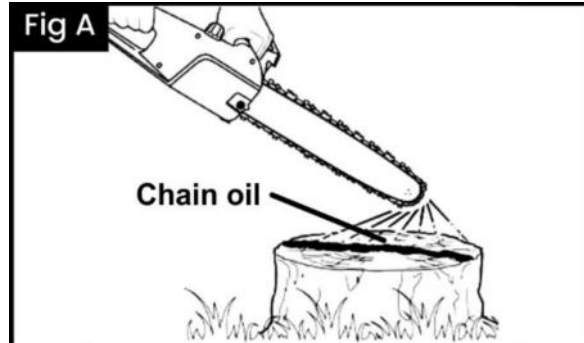

2. The oil adjustment screw is located under the chainsaw as shown in Figure B.
3. With a narrow flat-tipped screwdriver, adjust the flow of lubrication according to your work conditions.
 - a. To increase the oil flow, turn the automatic oiler adjustment screw counterclockwise
 - b. To decrease the oil flow, turn the automatic oiler adjustment screw clockwise.



STARTING THE ENGINE



BEFORE STARTING THE ENGINE:

- a. Inspect the equipment and engine.
- b. Fill the engine with the proper amount and type of unleaded gasoline and 2-cycle oil mixture.
- c. Fill the oil tank with the proper amount and type of bar and chain oil.

MANUAL START

A “Cold Start” is when the engine is no longer hot to the touch, typically at least 30 minutes after its last run.

1. To start a cold engine or first start of the day, ensure the Guide Bar and Saw Chain are not touching or near any object as Chain will spin during startup. Push the Hand Guard / Chain Brake Lever forward to engage the chain brake. Refer to Fig 8.

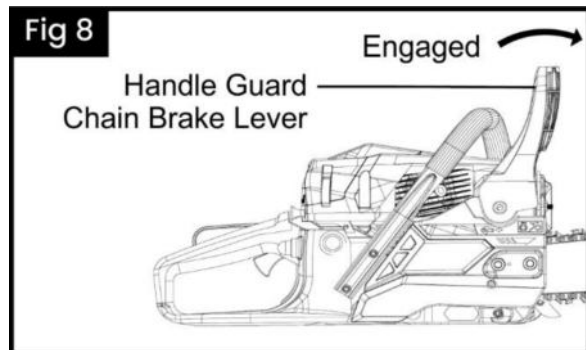

2. Put the engine switch to the “I” position. Refer to Fig 9.

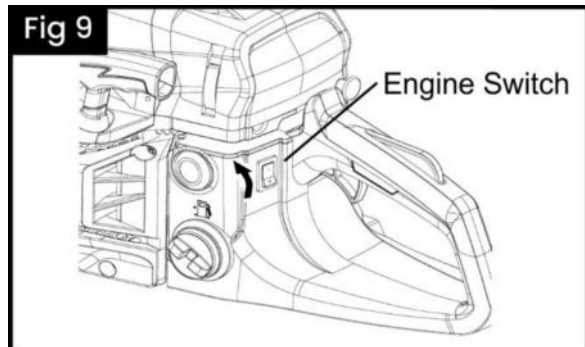

3. Press the Prime Bulb up to 10 times until the Bulb begins to fill with fuel. Refer to Fig 10.

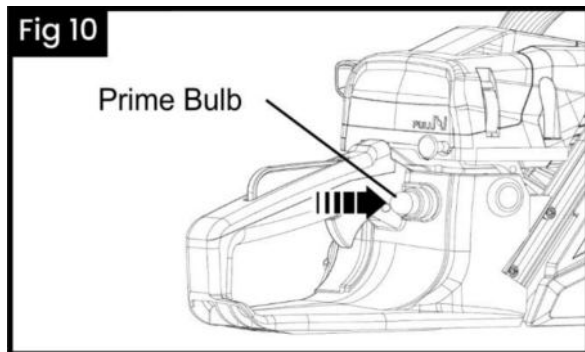

4. Pull out the Choke Knob to the START (closed) position. Refer to Fig 11.

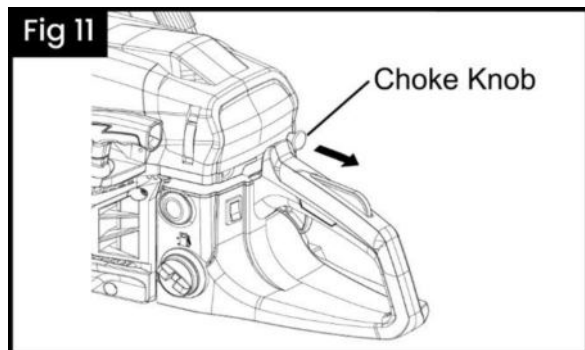

5. Hold the Chainsaw securely on the ground. Firmly grasp the Starter Handle and pull it rapidly until the engine sputters. Refer to Fig 12.

NOTE Do not let the Starter Handle snap back against the engine. Hold it as it recoils so it doesn't hit the engine.

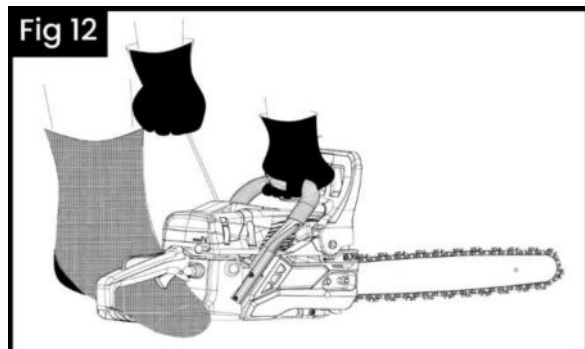

6. Press back the Choke Knob to the RUN (open) position—this will partially engage the throttle to assist starting. Pull the Starter Handle firmly and evenly until the engine starts. Immediately disengage the chain brake by pulling back on the Hand Guard / Chain Brake Lever.

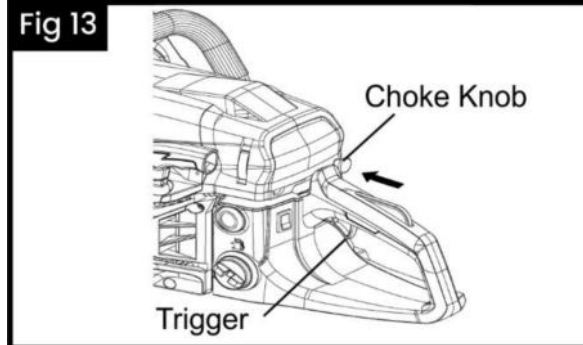

▲ CAUTION! The Saw Chain will immediately start spinning with the engine running at partial throttle. Allow the engine to run at partial throttle for 5 seconds. Quickly squeeze and then release the trigger to disengage the throttle assist and allow the engine to idle. Allow the engine to warm up at idle for 60 seconds after each start-up so that the engine can stabilize before use.

TO RESTART A WARM ENGINE

Follow the starting instructions found above with the following exception:

Omit the portion of Step 5 which states – Firmly grasp the Starter Handle and pull it rapidly until the engine sputters – and proceed to Step 6.

STOPPING THE ENGINE

1. To stop the engine in an emergency, release the Trigger and press the Stop Engine Switch.
2. Under normal conditions, use the following procedure:
 - a. Release the Trigger.
 - b. Let the engine idle for 3 to 5 minutes.
 - c. Press the Stop Engine Switch

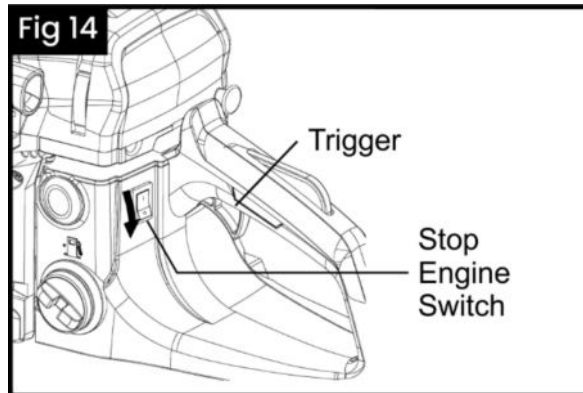

WORKPIECE AND WORK AREA SET UP

1. Designate a work area that is clean and well lit. The work area must not allow access by children or pets to prevent distraction and injury.
2. There must not be objects, such as utility lines, nearby that will present a hazard while working.
3. A first-time user should, as a minimum practice, cut logs on a sawhorse or cradle before cutting down trees.

GENERAL OPERATING INSTRUCTIONS

1. Before first use and before each use, thereafter, remove the Oil Tank Cap. Inspect the Cap Gasket for damage. Fill the Oil Tank to just below the fill plug with oil (not included). Refer to Specifications chart on page 2 for oil type. Then close the oil tank with the oil tank cap. Oil is automatically applied to the Saw Chain during operation.
2. Start the Engine as detailed in Starting the Engine on page 16. If necessary, adjust Engine idle speed so Saw Chain does not rotate at idle. To adjust, turn the Idle Adjusting Screw (T) counterclockwise to lower idle speed until Chain does not turn. Refer to Figure 15.

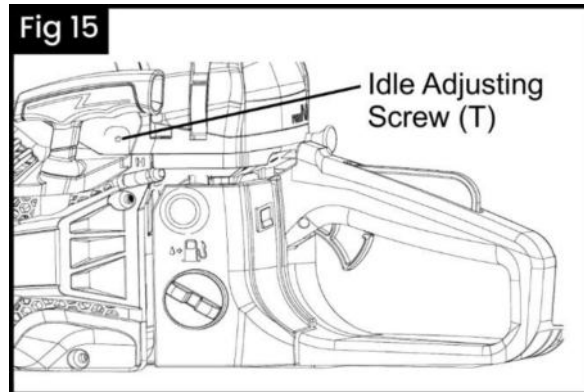

3. Place the Hand Guard / Chain Brake Lever in normal operating (disengaged) position by pulling the Hand Guard back toward the Handle. Refer to Figure 16.

NOTE The Chainsaw will not operate unless the Hand Guard / Chain Brake Lever is in the disengaged position.

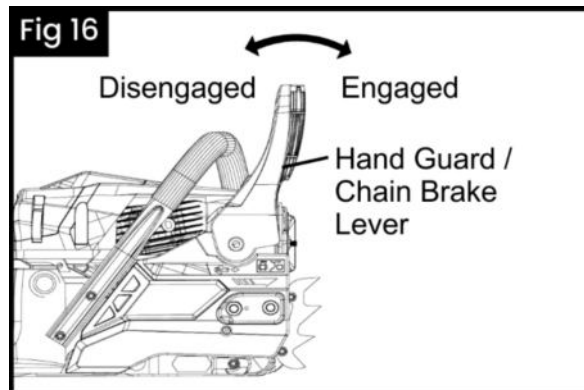

4. Grasp the Handles with both hands. Always grip the handle with the thumb and fingers encircling the handle as shown in Figure 17.

NOTE Front Hand Guard not shown.

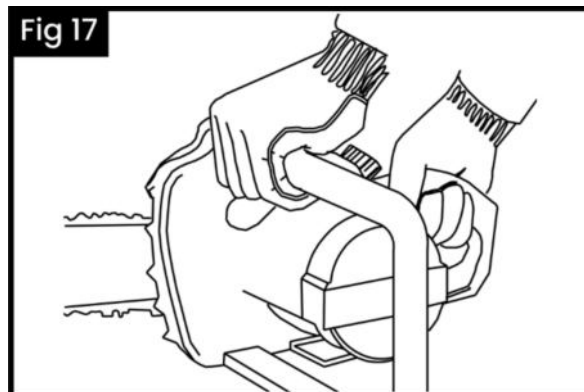

5. Stand in front of the wood to be cut with your feet firmly in place.
6. Grasp the Rear Handle to activate the Trigger Lockout Switch, then squeeze and hold the Trigger. Releasing the Trigger will return the Engine to idling speed.

NOTE The Trigger cannot be activated unless the Trigger Lockout Switch is depressed.

⚠ DANGER! To prevent serious injury and death from kickback: Do not touch the Guide Bar Nose to the wood.

7. When the Chainsaw reaches full speed, begin cutting with a light, downward pressure against the bottom mid-section of the Saw Chain. Allow the Saw Chain to cut at its own rate. Applying too much pressure can damage the tool.

⚠ DANGER! To prevent serious injury and death from kickback: When cutting loose, round wood stock, place the wood stock on a sawhorse, in a cradle, or use a timber jack (all sold separately) to avoid grabbing and throw back.

8. When cutting is complete release the Trigger, allow the Engine to idle 3 to 5 minutes, then press the Stop Engine Switch. To prevent accidents, place the Hand Guard / Chain Brake Lever forward in its engaged position after use.
9. When the Saw has cooled completely, clean thoroughly and cover the Chain Guide Bar with the Chain Guide Bar Sheath. Store the tool indoors out of children's reach. See Long-Term Storage on page 29 for complete storage instructions.

INSTRUCTIONS CONCERNING THE PROPER TECHNIQUES FOR BASIC FEELING, LIMBING, AND CROSS-CUTTING

When bucking and felling operations are being performed by two or more persons at the same time, the felling operations should be separated from the bucking operation by a distance of at least twice the height of the tree being felled. Trees should not be felled in a manner that would endanger any person, strike any utility line, or cause any property damage. If the tree does make contact with any utility line, the company should be notified immediately.

The chainsaw operator should keep on the uphill side of the terrain as the tree is likely to roll or slide downhill after it is felled.

An escape path should be planned and cleared as necessary before cuts are started. The escape path should extend back and diagonally to the rear of the expected line of fall as illustrated in Figure 18.

Before felling is started, consider the natural lean of the tree, the location of larger branches and the wind direction to judge which way the tree will fall.

Remove dirt, stones, loose bark, nails, staples, and wire from the tree.

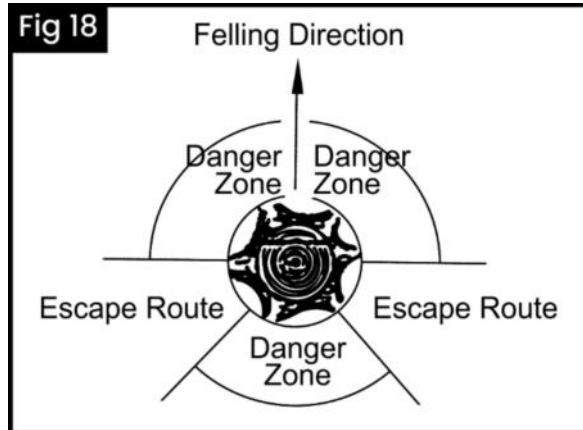

The spiked bumper must always be put on while using the chainsaw on the tree trunk. Push the spiked bumper into the tree trunk by using the rear handle. Push the front handle in the direction of the cutting line. The spiked bumper must be remaining set for further saw guiding if necessary. Using a spiked bumper when cutting trees and thick branches can ensure your safety and decrease the working strength and vibration level. If there's debris between the cutting material and chainsaw, turn off the machine. Wait until it stops completely. Wear safety gloves and remove the debris. If the chain must be removed, please follow the instructions of relevant part like installation in manual. A trial run must be conducted after the cleaning and re-installation. If vibration or mechanical noise is discovered, please stop the use, and contact your dealer.

NOTCHING UNDERCUT

Make the notch 1/3 the diameter of the tree, perpendicular to the direction of falls as illustrated in Figure 19. Make the lower horizontal notching cut first. This will help to avoid pinching either the saw chain or the guide bar when the second notch is being made.

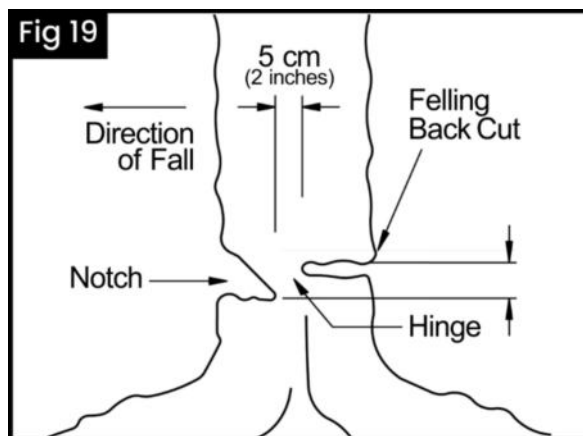

FELLING BACK CUT

Make the felling back cut at least 5 cm (2 inches) higher than the horizontal notching cut as illustrated in Figure 19. Keep the felling back cut parallel to the horizontal notching cut. Make the felling back cut so enough wood is left to act as a hinge. The hinge wood keeps the tree from twisting and falling in the wrong direction. Do not cut through the hinge. As the felling gets close to the hinge, the tree should begin to fall. If there is any chance that the tree may not fall in the desired direction or it may rock back and bind the saw chain, stop cutting before the felling back cut is complete and use wedges of wood, plastic, or aluminum to open the cut and drop the tree along the desired line of fall.

▲ IMPORTANT! When the tree begins to fall remove the chainsaw from the cut, stop the motor, put the chainsaw down, then use the retreat path planned. Be alert for overhead limbs falling and watch your footing.

LIMBING A TREE

Limbing is removing the branches from a fallen tree. When limbing leave larger lower limbs to support the log off the ground. Remove the small limbs in one cut as illustrated in Figure 20. Branches under tension should be cut from the bottom up to avoid binding the chainsaw.

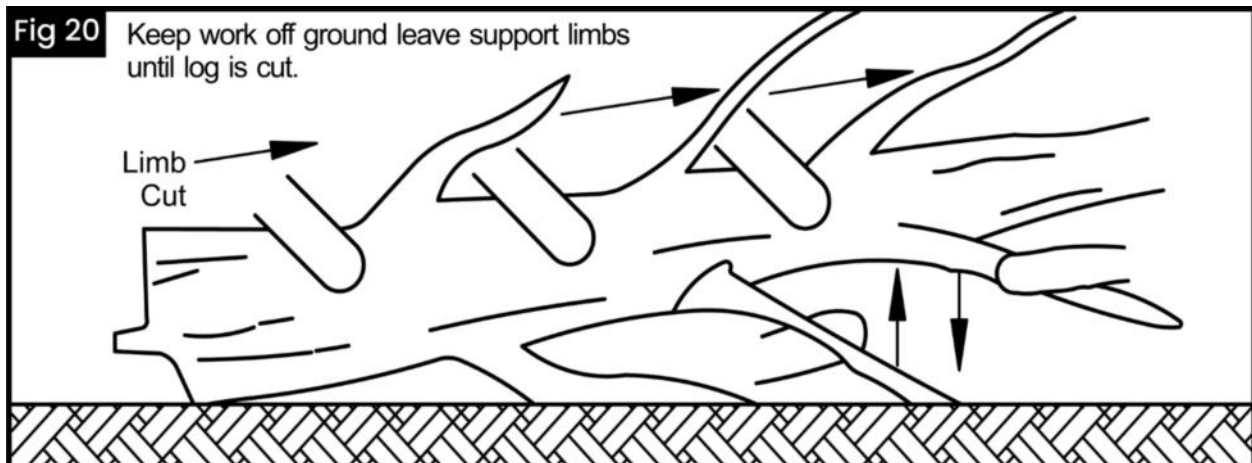

BUCKING A LOG

Bucking is cutting a log into lengths. It is important to make sure your footing is firm, and your weight is evenly distributed on both feet. When possible, the log should be raised and supported by the use of limbs, logs, or chocks. Follow the simple directions for easy cutting. When the log is supported along its entire length as illustrated in Figure 21, it is cut from the top (overbuck).

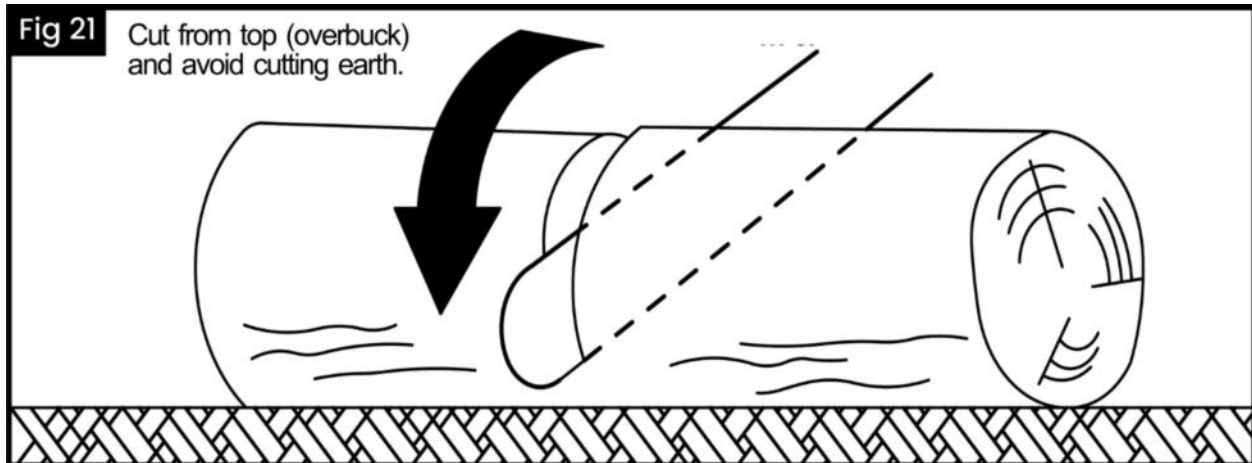

SUPPORTING A LOG

When the log is supported on one end, as illustrated in Figure 22, cut 1/3 the diameter from the underside (underbuck). Then make the finished cut by overbucking to meet the first cut.

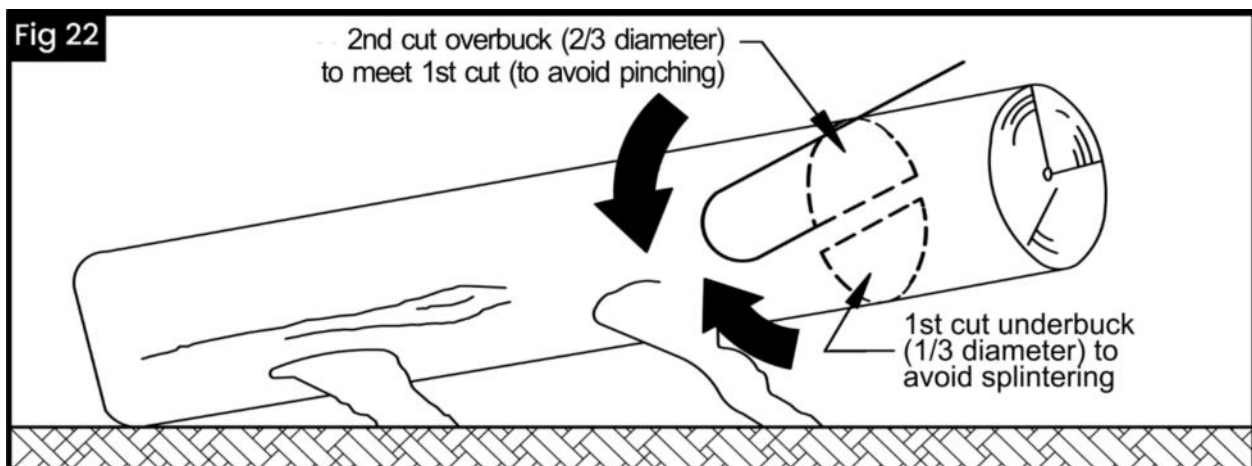

When the log is supported on both ends, as illustrated in Figure 23 cut 1/3 the diameter from the top (overbuck). Then make the finished cut by underbucking the lower 2/3 to meet the first cut.

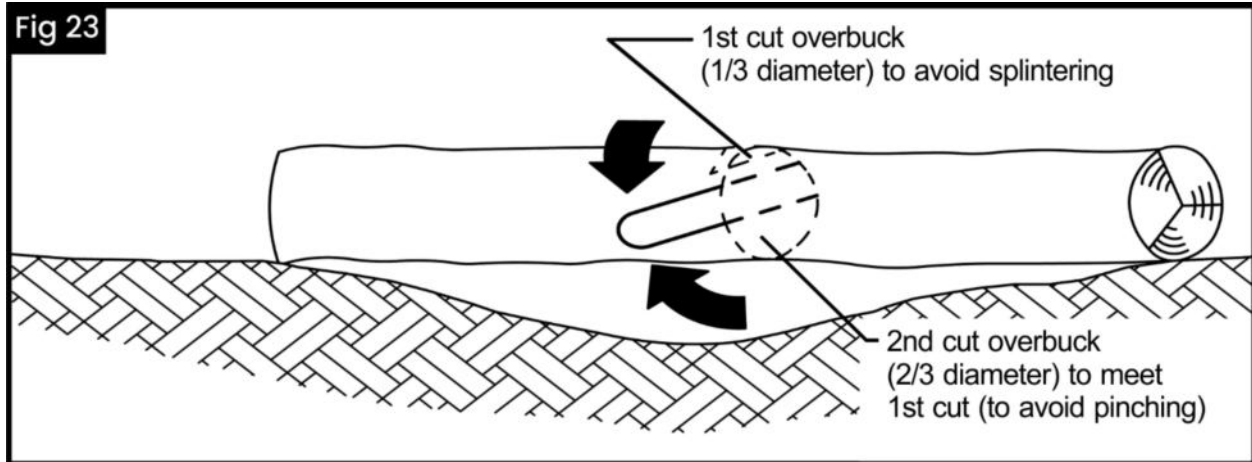

When bucking on a slope always stand on the uphill side of the log, as illustrated in Figure 24. When “cutting through”, to maintain complete control release the cutting pressure near the end of the cut without relaxing your grip on the chainsaw handles. Don’t let the chain contact the ground. After completing the cut, wait for the saw chain to stop before you move the chainsaw. Always stop the motor before moving from tree to tree.

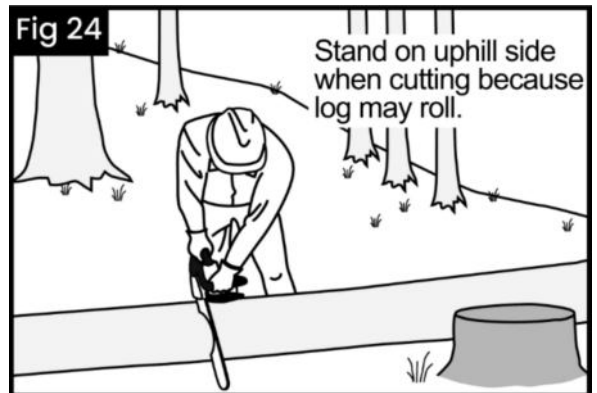

MAINTENANCE

⚠ WARNING!

TO PREVENT SERIOUS INJURY FROM ACCIDENTAL STARTING:

Turn the Power Switch of the equipment to its “OFF” position, wait for the engine to cool, and disconnect the spark plug cap before performing any inspection, maintenance, or cleaning procedures.



TO PREVENT SERIOUS INJURY FROM EQUIPMENT FAILURE:

Do not use damaged equipment. If abnormal noise, vibration, or excess smoking occurs, maintenance procedures, including any not detailed in this manual, will need to be performed by a qualified technician for safety. If you have any doubts about your ability to safely service the equipment or engine, contact customer service and have an approved technician service the equipment instead.

CLEANING, MAINTENANCE, AND LUBRICATION

1. **BEFORE EACH USE**, inspect the general condition of the tool. Check for:
 - Loose hardware
 - Misalignment or binding of moving parts
 - Cracked or broken parts
 - Dull or damaged saw chain
 - Any other condition that may affect its safe operation
2. **BEFORE FIRST USE AND BEFORE EACH USE THEREAFTER**, make sure the Oil Tank is filled with oil (not included). Refer to Specifications Chart on page 2 for oil type.
3. **IF THE SAW CHAIN BECOMES LOOSE**, adjust the Saw Chain tension as described under Adjusting Saw Chain Tension on page 13.
4. **PERIODICALLY OR WHEN REPLACING SAW CHAIN**, turn the Chain Guide Bar over to distribute the wear on it. Replace the Guide Bar when bent, cracked, or when the Saw Chain moves excessively from side to side on the Guide Bar due to wear. Refer to Chain Guide Bar Care on page 29.

⚠ WARNING! TO PREVENT SERIOUS INJURY:

Replace the Saw Chain and Guide Bar only with an identical Saw Chain and Guide Bar.

5. **AFTER USE**, when the Saw has cooled completely, clean thoroughly and cover the Chain Guide Bar with the Chain Guide Bar Sheath. Do not use solvents. Do not immerse this tool in liquid. Store the tool indoors out of children's reach. See Long-Term Storage on page 31 for complete storage instructions.

NOTE This maintenance schedule is intended solely as a general guide. If performance decreases or if equipment operates unusually, check systems immediately. The maintenance needs of each piece of equipment will differ depending on factors such as duty cycle, temperature, air quality, fuel quality, and other factors. If you have doubts about your ability to safely service this tool, contact customer service and have an approved technician service the equipment instead.

NOTE The following procedures are in addition to the regular checks and maintenance explained as part of the regular operation of the engine and equipment.

Procedure	Before Each Use	Monthly or every 10 hours of use	Every 3 months or every 20 hours of use	Every 6 months or every 50 hours of use	Yearly or every 100 hours of use	Every 2 Years
Check engine fuel/oil mixture level	X	X				
Change fuel filter	X	X			X	X
Clean air filter			X *	X	X	X
Check and clean spark plug				X	X	X
Check/adjust idle speed	X	X				
1.Clean fuel tank and carburetor 2.Clean carbon build-up from combustion chamber					X **	X **
Replace fuel line if necessary						X **

* Service more frequently when used in dusty areas.

** Contact customer service. These items should be serviced by an authorized service technician.

PERIODIC MAINTENANCE OR WHEN REPLACING SAW CHAIN:

- a. Clean and lubricate the Chain Guide Bar and turn over.
- b. Deburr Guide Bar as needed.
- c. Check Chain Sprocket for wear or damage.

MONTHLY MAINTENANCE:

Clean Chain Oil Tank.

IF WORN OR DAMAGED:

- a. Replace Chain Guide Bar if it becomes worn, bent or damaged.
- b. Sharpen or replace Saw Chain.



SHARPENING/REPLACING THE SAW CHAIN

⚠ CAUTION! Wear heavy-duty work gloves when handling the Saw Chain.

1. For smooth and safe operation, always keep the Saw Chain cutters sharp.
2. Have the cutters sharpened by a qualified technician when you notice any of the following symptoms:
 - a. The sawdust becomes powder-like.
 - b. You can't make the cut without extra force.
 - c. The Chainsaw does not cut straight.
 - d. Vibration increases.
3. A Saw Chain that is damaged or too worn to be restored to a usable condition by sharpening will need to be replaced. Refer to Guide Bar / Saw Chain Installation/Replacement on page 11.

⚠ WARNING! TO PREVENT SERIOUS INJURY:
Replace the Saw Chain only with an identical Saw Chain.

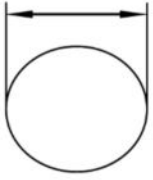
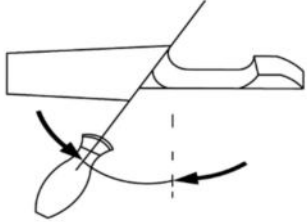
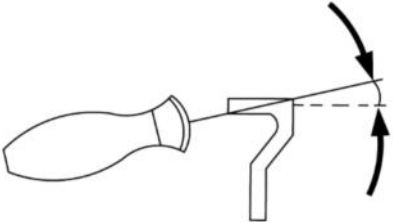
Don't use a replacement saw chain unless it has been designated as meeting the kickback performance requirements in **ANSI/OPEI B175.1-2012** on that specific power head. A low-kickback saw chain is a chain that has met the kickback performance requirements of **ANSI/OPEI B175.1-2012** when tested according to the provisions specified in **ANSI/OPEI B175.1-2012**.

File diameter	Top plate angle	Down angle	Side angle
			
3 ml (3/16 inch)	30°	10°	70°

CHAIN GUIDE BAR CARE

1. Remove the Chain Guide Bar periodically to clean and lubricate.
2. Deburr rails of Guide Bar as needed. Use a flat file to make the side edges square.
3. Remove sawdust and sap from the Bar Groove using a Guide Bar cleaning tool (sold separately), then lubricate the nose sprocket at ports with grease.
4. Reverse the Guide Bar when replacing the Saw Chain to prevent uneven wear.
5. The rails of the Guide Bar groove should always be parallel to each other. Place a ruler along the surface of the Guide Bar and Saw Chain. If there is a gap, the bar is normal. Refer to Fig 25 and Fig 26.

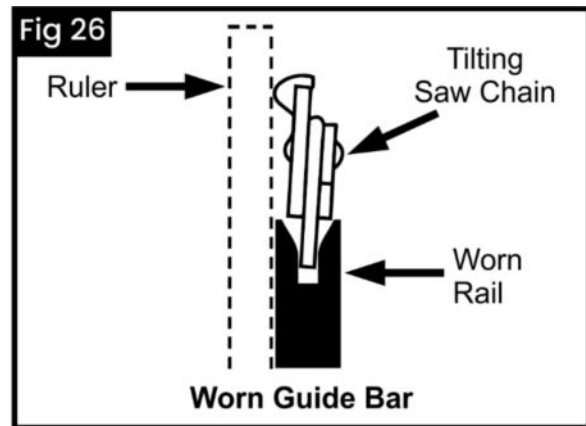
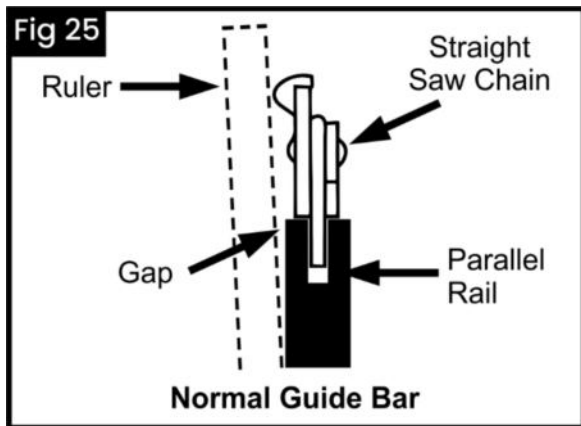

SPARK PLUG MAINTENANCE

1. Remove the Air Filter Cover.
2. Disconnect Spark Plug Cap from end of plug. Clean out debris from around Spark Plug.
3. Using a spark plug wrench, remove the Spark Plug.
4. Inspect the Spark Plug: If the electrode is oily, clean it using a clean, dry rag. If the electrode has deposits on it, polish it using emery paper. If the white insulator is cracked or chipped, the spark plug needs to be replaced

Recommended Spark Plugs	
Bosch®	L8RTF
Champion®	RCJ7Y
NGK®	BPMR7A

NOTE Using an incorrect spark plug may damage the engine.

5. When installing a new spark plug, adjust the plug's gap to the specification on the Specifications chart. Do not pry against the electrode, the spark plug can be damaged.
6. Install the new spark plug or the cleaned spark plug into the engine.
 - **Gasket style:** Finger-tighten until the gasket contacts the cylinder head, then tighten about 1/2-2/3 turn more.
 - **Non-gasket style:** Finger-tighten until the plug contacts the cylinder head, then tighten about 1/16 turn more.

NOTE Tighten the Spark Plug properly. If loose, the Spark Plug will cause the engine to overheat. If overtightened, the threads in the engine block will be damaged.

7. Reattach the Spark Plug Cap securely.

AIR FILTER MAINTENANCE

1. Remove the Air Filter Cover and the Air Filter and check for dirt. Clean or replace as described below. Refer to Fig 28.
2. To prevent injury from dust and debris, wear ANSI-approved safety goggles, NIOSH-approved dust mask/respirator, and heavy-duty work gloves. Remove dust on the Filter surface by tapping a corner of the Filter against a hard surface. In a well-ventilated area away from the bystanders, use pressurized air to blow dust out of the Filter from the inside.
3. Install the new or cleaned filter. Reinstall and secure the Air Filter Cover before use.

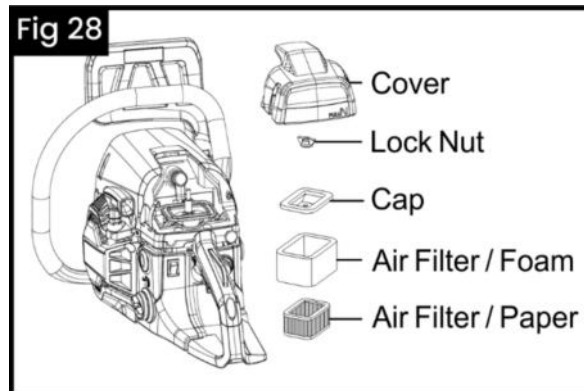

FUEL FILTER MAINTENANCE

1. Clean the Fuel Tank Cap and the area around it.
2. Remove the Fuel Tank Cap from the Fuel Tank.
3. Use a suction pump (not included) to pump any fuel in the Tank into a proper gasoline container.
4. Use a piece of wire with a hook on one end to carefully extract the Fuel Filter from the Tank
5. Remove used filter from fuel line. Attach a new filter to the fuel line and reinsert it into the Fuel Tank. Refer to Fig 29.
6. Replace Fuel Tank Cap and tighten securely.

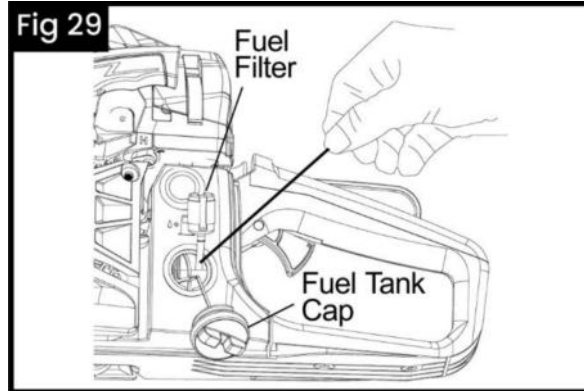
**LONG-TERM STORAGE**

When the equipment is to remain idle for longer than 20 days, prepare the Engine for storage as follows:

1. **CLEANING:** Wait for Engine to cool, then clean Engine with dry cloth.

NOTE Do not clean using water. The water will gradually enter the Engine and cause rust damage. Apply a thin coat of rust preventative oil to all metal parts.

2. **FUEL:**

▲ WARNING!   **TO PREVENT SERIOUS INJURY FROM FIRE:**

Drain the Fuel Tank in a well-ventilated area away from ignition sources. If the Engine is hot from use, shut the Engine off and wait for it to cool before draining fuel. Do not smoke.

- a. Remove the Fuel Tank Cap and drain any remaining fuel into an approved storage container.
- b. Press the Prime Bulb 10 times.
- c. Drain any residual fuel into the storage container.
- d. Start the Engine and run at idle until the Engine stalls from lack of fuel.
- e. Replace Fuel Tank Cap and tighten securely.

3. **LUBRICATION:**
 - a. Clean out area around spark plug. Remove spark plug and pour 7.4ml (½ tablespoon) of 2-stroke oil into cylinder through spark plug hole.
 - b. Insert spark plug, but leave spark plug cap disconnected.
 - c. Pull Starter Handle to distribute oil in cylinder. Stop after one or two revolutions when you feel the piston start the compression stroke (when you start to feel resistance).
 - d. Remove all residual bar and chain oil from the Oil Tank.
4. **STORAGE AREA:** Cover and store in a dry, level, well-ventilated area out of reach of children. Storage area should also be away from ignition sources, such as water heaters, clothes dryers, and furnaces.
5. **AFTER STORAGE:** Before starting the Engine after storage, follow the checks and procedures under Controls and Operations beginning on page 15. If using pre-mixed fuel that has been stored, keep in mind that during storage some of the gasoline in the fuel evaporates while the 2-stroke oil does not, altering the gasoline-to-oil mix ratio. Running the Engine with an improper mixture WILL permanently damage the Engine. Use freshly mixed fuel when starting the Engine after storage.

TROUBLESHOOTING

Problem	Possible Causes	Problem Solutions
Engine will not start	FUEL RELATED	FUEL RELATED
	No fuel in tank.	Fill fuel tank with fresh 87+ octane stabilizer-treated unleaded gasoline/oil mixture only. Do not use gasoline with more than 10% ethanol (E15, E20, E85, etc.).
	Choke not in START position, cold engine.	Move Choke to START position.
	Gasoline with more than 10% ethanol used. (E15, E20, E85, etc.)	Clean out ethanol-rich gasoline from fuel system. Replace components damaged by ethanol. Use fresh 87+ octane stabilizer-treated unleaded gasoline/oil mixture only. Do not use gasoline with more than 10% ethanol (E15, E20, E85, etc.).
	Low quality or deteriorated, old gasoline/oil mixture.	Use fresh 87+ octane stabilizer-treated unleaded gasoline/oil mixture. Do not use gasoline with more than 10% ethanol (E15, E20, E85, etc.).
	Carburetor not primed.	Press the Prime Bulb several times to prime.
	Dirty fuel passageways.	Clean out passageways using fuel additive. Heavy deposits may require further cleaning.
Carburetor is flooded.	Turn Choke Knob to RUN position. Pull Starter Handle 10-20 times to clear out Carburetor, then attempt to start with normal process.	



Follow all safety precautions whenever diagnosing or servicing the equipment or engine.

Problem	Possible Causes	Problem Solutions
Engine will not start (continued)	IGNITION (SPARK) RELATED:	IGNITION (SPARK) RELATED:
	Spark plug cap not connected securely.	Connect spark plug cap properly.
	Spark plug electrode wet or dirty.	Clean spark plug.
	Incorrect spark plug gap.	Correct spark plug gap.
	Spark plug cap broken.	Replace spark plug cap.
	Incorrect spark timing or faulty ignition system	Contact customer service and have an approved technician diagnose/repair ignition system.
	COMPRESSION RELATED:	COMPRESSION RELATED:
Cylinder not lubricated. Problem after long storage periods.	Pour ½ tablespoon of oil into spark plug hole. Crank engine a few times and try to start again.	
Loose or broken spark plug. (Hissing noise will occur)	Tighten spark plug. If that does not work, replace spark plug.	
Engine misfires	Spark plug cap loose.	Check cap and wire connections.
	Incorrect spark plug gap or damaged spark plug.	Re-gap or replace spark plug.
	Defective spark plug cap.	Replace spark plug cap.
	Old or low quality gasoline/oil mixture.	Use only fresh 87+ octane stabilizer-treated unleaded gasoline/oil mixture. Do not use gasoline with more than 10% ethanol (E15, E20, E85, etc.).
	Incorrect compression.	Diagnose and repair compression. (Use Engine will not start: COMPRESSION RELATED section.)
Engine stops suddenly	Fuel tank empty or full of impure or low quality gasoline/oil mixture.	Fill fuel tank with fresh 87+ octane stabilizer-treated unleaded gasoline/oil mixture. Do not use gasoline with more than 10% ethanol (E15, E20, E85, etc.).
	Defective breather valve creating vacuum, preventing proper fuel flow.	Test/replace breather valve.
	Faulty magneto.	Contact customer service and have an approved technician service magneto.
	Disconnected or improperly connected spark plug cap.	Secure spark plug cap.

Problem	Possible Causes	Problem Solutions
Engine stops when under heavy load	Dirty air filter	Clean element.
	Engine running cold.	Allow engine to warm up prior to operating equipment.
Engine knocks	Old or low quality gasoline/oil mixture.	Fill fuel tank with fresh 87+ octane stabilizer-treated unleaded gasoline/oil mixture. Do not use gasoline with more than 10% ethanol (E15, E20, E85, etc.).
	Engine overloaded.	Do not exceed equipment's load rating.
	Incorrect spark timing, deposit buildup, worn engine, or other mechanical problems.	Contact customer service and have an approved technician diagnose and service engine.
After sudden impact, engine will run, but equipment will not operate	Shaft key or other shear pin broken by impact to disconnect engine and limit damage.	Contact customer service and have an approved technician check and replace broken shaft key or other shear pins.
Engine runs, but Chain does not rotate	Chain tension too tight.	Adjust Saw Chain tension.
	Guide Bar and/or Chain damaged.	Inspect Guide Bar and Chain for damage. Replace Guide Bar and Chain if necessary.
	Chain drive sprocket worn.	Contact customer service and have an approved technician service tool.
	Chain brake is engaged.	Disengage the chain brake.
Engine runs, Chain rotates but does not cut or cuts poorly	Saw Chain not tensioned properly.	Tension Saw Chain properly.
	Saw Chain dull.	Sharpen Saw Chain or replace.
	Saw Chain installed backwards.	Reverse direction of Saw Chain.
Chain comes off Guide Bar	Chain tension too loose.	Adjust Saw Chain tension.
	Guide Bar and Chain not installed correctly.	Review and correct Guide Bar and Chain installation.
Guide Bar and Chain running hot	Chain tension too tight.	Adjust Saw Chain tension.
	Oil Tank empty.	Check/refill Oil Tank.

 Follow all safety precautions whenever diagnosing or servicing the equipment or engine.

18IN 45CC CHAINSAW**5240-186**

No.	Description	Qty	No.	Description	Qty
1	Clutch Cover Assembly	1	47	Start Plate	1
2	Screw M5x40	1	48	Easily Actuated Coil Spring Cover	1
3	Pin Gland 5x6.3x30	1	49	Easily Actuated Coil Spring	1
4	Heavy Brock Gland 6.3x9x15	1	50	Sheathing LH	1
5	Front Damper	1	50A	Starter Housing Assembly	1
6	Heavy Brock	1	51	Starter Housing	1
7	Heavy Brock Spring	1	52	Starter Handle	1
8	Brake Torsion Rod Spring	1	53	Starter Pull Cord	1
9	Washer 5.2x20x1.2	1	54	Pull Cord Sheath	1
10	Lock- Nut M5	1	55	Starter Cover Liner	1
11	Spring Base	1	55A	Label	1
12	Front Guard Spring	1	56	Screw M5x18	4
13	Tensioner Cover Plate	1	57	Fuel Tube	1
14	Pin Φ 3x14	1	58	Circlip	1
15	Main Level	1	59	Fuel Filter	1
16	Secondary Pull-Rod	1	60	Shock Rubber	1
17	Pin 3x9	3	61	Base	1
18	Break Control Rod	1	62	Dust Cover	2
19	Brake Spring	1	63	Rear Handle Fixing Screw	2
20	Break Strap	1	64	Shock Rubber Gland	1
21	Self-Tapping Screw ST4.2x9.5	6	65	Oil Cover	2
22	Break Spring Cover Plate	1	66	Packing Washing 23x34x1.7	1
23	Tightener Screw	1	67	Anti-Drop Plate	1
24	Tension Block	1	68	Self-Tapping Screw ST4x5	1
25	Tension Gear	1	69	Fixed Leaf	1
26	Chain Guide Block	1	70	Sleeve Spring	1
27	Dust Shield	1	71	Throttle Trigger Lock-Out	1
28	Clutch Cover	1	72	Rear Handle Cover	1
29	Nut M8	2	73	Self-Tapping Screw ST4.8x14	1
30	Right Cover Label	1	74	Primer Bulb	1
31	Air Filter Cover	1	75	Pump Tube 2.5x5x155	1
32	Screw M5x16	5	76	Cover Buckle	1
33	Upper Cover Part	1	77	Switch	1
33A	Upper Cover	1	78	Ground Lead	1
34	Clip	2	79	Screw M5x10	1
35	Cards And Pressure Plates	2	80	Self-Tapping Screw ST5x16	4
36	Self-Tapping Screw ST2.9x6.5	4	81	Front Handle	1
37	Clip Fixing Plate	2	82	Throttle Rod	1
38	Top Cover Air Guide Sheet	1	83	Throttle Trigger	1
39	Self-Tapping Screw ST3.5x6	3	84	Throttle Trigger Spring	1
40	Aluminum Septum / Cylinder Shield	1	85	Pin Φ 6x24	1
41	Flow Guiding Cover	1	86	Oil Nozzle	1
42	Starter Assembly	1	87	Balancer	1
43	Self-Tapping Screw ST4.8x14	1	88	Balancer Seat	1
44	Plate Washer 5	1	89	Guide Sleeve 18 Inch	1
45	Easy Start-Coil Spring Cover	1	90	Saw Chain 18 Inch	1
46	Easy Start-Coil Spring	1	91	Guide Bar 18 Inch	1

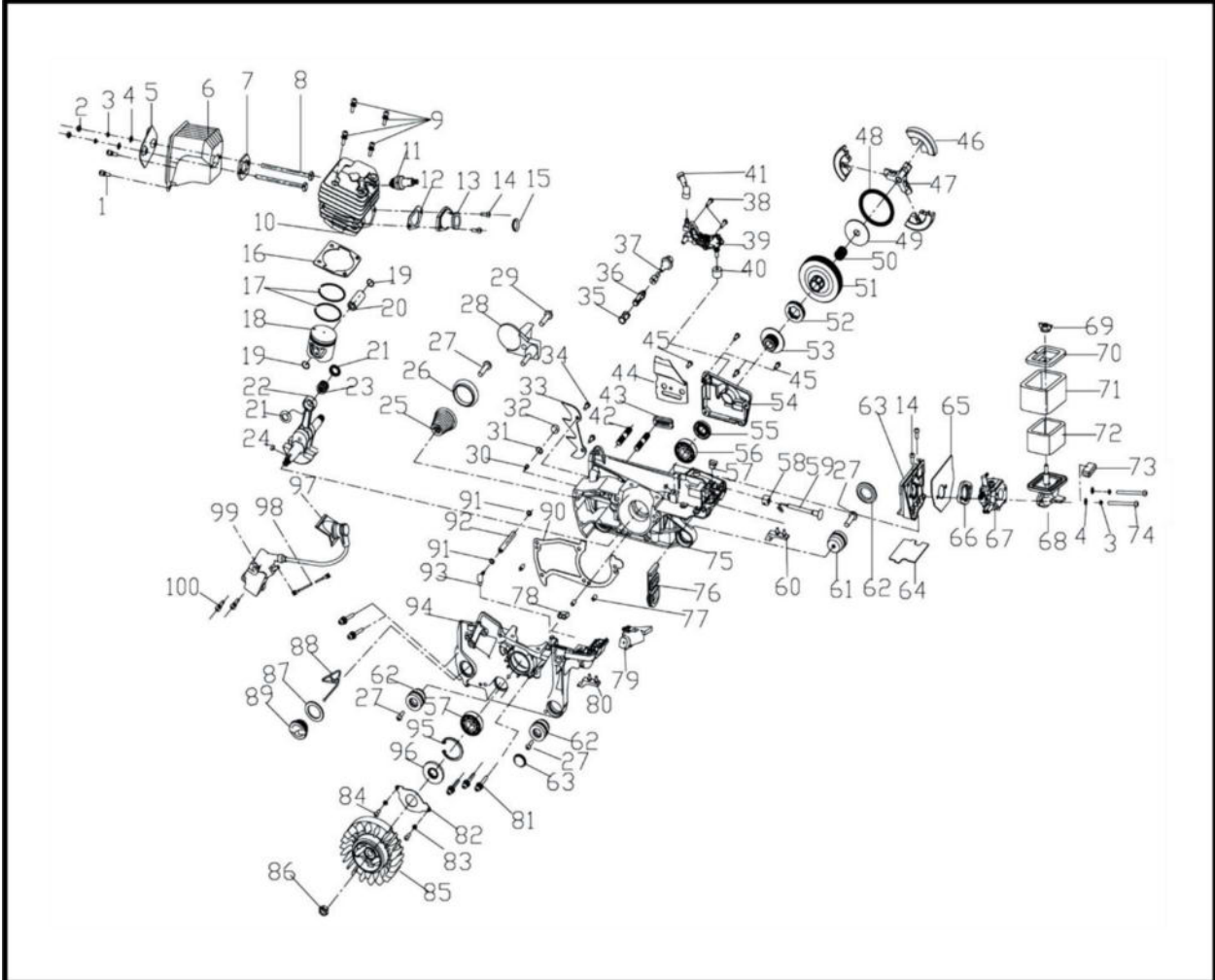

18IN 45CC CHAINSAW**5240-186**

No.	Description	Qty
1	Screw M5x14	2
2	Nut M5	2
3	Washer 5	4
4	Washer 5	4
5	Muffler Cover Plate	1
6	Muffler	1
7	Muffler Sealing Plate	1
8	Muffler Connecting Screw	2
9	Screw M5x20	4
10	Cylinder Body	1
11	Spark Plug	1
12	Air Intake Tube Sealing Plate	1
13	Air Intake Tube	1
14	Screw M5x12	4
15	Hold Coil	1
16	Cylinder Sealing Plate	1
17	Piston Ring	2
18	Piston	1
19	Piston Pin Circlip	2
20	Piston Pin	1
21	Needle Bearing Ring	2
22	Crankshaft Connecting Rod	1
23	Needle Bearing 11x15x12.5	1
24	Semicircular Key 3x3.7x10	1
25	Conical Spreader Spring	1
26	Conical Spreader Base	1
27	Self-Tapping Screw ST5x16	4
28	Chain Catcher	1
29	Screw M5x16	1
30	Aeration Jet	1
31	Aeration Jet Circlip	1
32	Sponge Transition Block	1
33	Bumper Spikes	1
34	Screw M5x10	2
35	Oil Filter Screen	1
36	Oil Filter	1
37	Oil Tube	1
38	Screw M4x14	2
39	Oil Pump	1

No.	Description	Qty
40	Sponge Transition Coil	1
41	Nozzle	1
42	Double-Screw Bolt Am8-M8x26-8.8	2
43	Chain Guide Block	1
44	Damper	1
45	Screw M4x10	4
46	Shoe Block	3
47	Retainer	1
48	Clutch Extension Spring	1
49	Clutch Adjusting Washer	1
50	Needle Bearing 12x15x14.5	1
51	Clutch Shell	1
52	Sprocket	1
53	Turbine	1
54	Cover Plate	1
55	Oil Seal 15x28x4.5	1
56	Bearing 6202 Grade D 15x35x11	2
57	Shock Block 1	1
58	Throttle Lever Retaining Bracket	1
59	Throttle Rod	1
60	Right Shock Block	1
61	Cushion Socket	3
62	Dust Cover	3
63	Air Intake Support	1
64	Backing Board	1
65	Sealing Plate Of Air Intake Support	1
66	Air Intake Flange	1
67	Carburetor	1
68	Air Intake Socket	1
69	Air Filter Lock Nut	1
70	Air Filter Cover	1
71	Air Cleaner Foam	1
72	Air Filter	1
73	Cushion Of Air Intake Socket	1
74	Nut M5x50	2
75	Right Case Body	1
76	Dust Plate	1
77	Pin Φ 5x10	3
78	Idle Adjusting Guide Set	1



No.	Description	Qty	No.	Description	Qty
79	Idle Adjusting Guide Set	1	90	Case Body Sealing Plate	1
80	Left Shock Block	1	91	Circlip	2
81	Screw M5×25	5	92	Suction Tube 2.5×7×105	1
82	Oil Seal Damper	1	93	Suction Jet	1
83	Washer 4	2	94	Left Case Body	1
84	Screw M4×8	2	95	Ring 35	1
85	Flywheel	1	96	Oil Seal 15×35×4.5	1
86	Nut M8×1	1	97	Igniter Cap	1
87	Packing Washing 20×30×2	1	98	Extinction Conductor	1
88	Anti-Drop Plate	1	99	Igniter	1
89	Oil Cover	1	100	Screw M5×20	2

WARRANTY

This product is distributed by:

HOME HARDWARE

34 Henry Street West,
St. Jacobs, ON N0B 2N0, Canada.
www.homehardware.ca

Please direct all service requests to:

MECANAIR

1380 Newton Street, Suite 109,
Boucherville, (Québec) J4B 5H2, Canada

Phone: 1.866.206.0888 (ext. 322)

www.mecanair.net

WARRANTY

HOME HARDWARE partners with MECANAIR to service this product. Beginning at the time of retail purchase and for the duration of the warranty period HOME HARDWARE warrants that Equipment manufactured by it is warranted to be free from defects in material and workmanship. MECANAIR will, at its sole discretion, replace or repair any part(s) which, upon evaluation and testing by MECANAIR or an authorized service center, show a defect in workmanship or material. Valid proof of purchase must be submitted online for registration with MECANAIR, or presented to MECANAIR at time of claim, for the warranty to be valid. This warranty is not transferable from the original owner.

WARRANTY PERIOD:**Non-commercial use:**

Year 1, 2, 3, 4, 5 – Parts and labor

Commercial use:

First 6 Months – Parts and labor

Replacement parts sold to a consumer or installed by an authorized service center are warranted for a period of 90 days from date of purchase. Labor must be performed by an authorized service center unless given MECANAIR's prior written approval. MECANAIR will not bear any transportation or shipping fees to or from an authorized service center. Service calls, travel charges, overtime, or weekend rates, are not covered.

THIS WARRANTY DOES NOT COVER:

Any repairs as a result of any parts not supplied by MECANAIR, and this part is responsible for the failure or malfunction.

- Any Machine modified, altered, disassembled, or remodeled,
- Any repairs required as a result of a failure to install, maintain, store, transport, or operate the Equipment in accordance with standard practices set out in the operator's manual.
- Damage that occurred after receipt of machine, not caused by defects in workmanship or materials.
- Normal maintenance services, as outlined in the operator's manual and intended for consumer to perform.
- Replacement of parts made in connection with normal maintenance services including oils, fuel, filters, brushes, belts, lubricants, spark plugs, gaskets, seals, fasteners, wires, tubes, pipes, fittings, wheels, batteries, and other expendables susceptible to natural wear.
- Any accessory or attachment.

Any battery supplied with this Equipment is considered a consumable item and is excluded from this warranty. Batteries can be damaged by shock, shorting terminals, heat, acid spillage, neglect, and other factors. It is the customer's responsibility to take great care when handling a battery so no spillage of acid occurs which may cause corrosion.

MECANAIR disclaims any responsibility for loss of time or use of the product, transportation, or towing costs or any other indirect, incidental, or consequential damage, inconvenience, or commercial loss.

This warranty is the entire and only warranty given by MECANAIR. No agent or employee is authorized to extend or enlarge this warranty on behalf of MECANAIR by any written or verbal statement or advertisement.

OTHER STATES, U.S. TERRITORIES, AND CANADA:

In other areas of the United States and in Canada, your engine must be designed, built, and equipped to meet the U.S. EPA and Environment Canada emission standards for spark-ignited engines at or below 19 kilowatts.



ALL OF THE UNITED STATES AND CANADA:

MECANAIR must warrant the emission control system on your power equipment engine for the period of time listed below, provided there has been no abuse, neglect, or improper maintenance of your power equipment engine. Where a warrantable condition exists, MECANAIR will repair your power equipment engine at no cost to you including diagnosis, parts, and labor.

CALIFORNIA:

The California Air Resources Board and MECANAIR are pleased to explain the emission control system warranty on your LONCIN engine. In California, new spark-ignited small off-road equipment engines must be designed, built, and equipped to meet the State’s stringent anti-smog standards.

Your emission control system may include such parts as the carburetor or fuel injection system, the ignition system, and catalytic converter. Also included may be hoses, connectors, and other emission-related assemblies.

EMISSION CONTROL SYSTEM WARRANTY PARTS:

This list applies to parts supplied by MECANAIR and does not cover parts supplied by the equipment manufacturer. Please see the original equipment manufacturer’s emissions warranty for non- MECANAIR parts.

Consumable parts are covered up to 30 days from workmanship or material defect.

SYSTEMS COVERED IN WARRANTY	PARTS DESCRIPTION
Fuel Metering	Carburetor assembly (includes starting enrichment system), Engine temperature sensor, Engine control module, Fuel regulator, Intake manifold
Evaporative	Fuel Tank, Fuel Cap, Fuel Hoses, Vapor Hoses, Carbon Canister, Canister Mounting Brackets, Fuel Strainer, Fuel cock, Fuel Pump, Fuel Hose Joint, Canister Purge Hose Joint
Exhaust	Catalyst, Exhaust Manifold
Air Induction	Air filter housing, Air filter element
Ignition	Flywheel magneto, Ignition pulse generator, Crankshaft position sensor, Power coil, Ignition coil assembly, Ignition control module, Spark plug cap, Spark plug
Crankcase Emission Control	Crankcase breather tube, Oil filler cap
Miscellaneous Parts	Tubing, fittings, seals, gaskets, and clamps associated with these listed systems

18IN 45CC CHAINSAW

5240-186

GAS CHAINSAW 18IN 45CC OWNER'S MANUAL

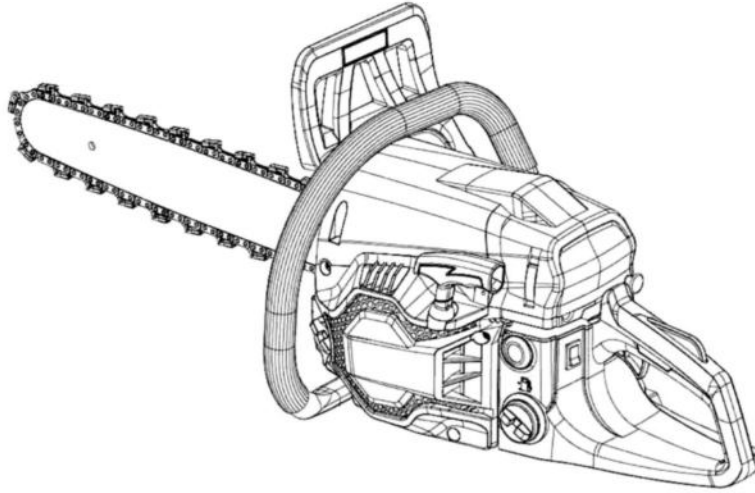

BENCHMARK™
MC

BENCHMARK TOOLS CANADA
ST. JACOBS, ONTARIO N0B 2N0
© 2024 Home Hardware Stores Limited
CUSTOMER SERVICE/TECH SUPPORT
1-866-206-0888 (ext. 322) or www.mecanair.net

5240-186

Made in China



* This Benchmark™ products are exclusive to Home Hardware and are guaranteed against defects in materials and workmanship, not against wear or misuse.



**READ ALL INSTRUCTIONS BEFORE FIRST USE.
KEEP THIS MANUAL FOR FUTURE REFERENCE.
KEEP AWAY FROM CHILDREN.**



**WEAR CSA APPROVED
EYE PROTECTION**



**WEAR EAR
PROTECTION**



**WEAR A
FACE MASK**