

Radley®

20" 52CC CHAINSAW

OWNER'S MANUAL



3 Year Limited Warranty on tool

*3 Year
warranty*



**READ ALL INSTRUCTIONS BEFORE FIRST USE.
KEEP THIS MANUAL FOR FUTURE REFERENCE.
KEEP AWAY FROM CHILDREN.**



**WEAR CSA APPROVED
EYE PROTECTION**



**WEAR EAR
PROTECTION**



**WEAR FACE
PROTECTION**

PRODUCT SPECIFICATIONS

RADLEY 20" 52CC CHAINSAW	
Displacement cc/cm ³	52
Max. Output (kW /RPM)	2.0 / 8500
Fuel	Gas to oil (two cycle) 50:1
Fuel tank capacity	18 ozs. / 530 ml
Chain oil	Motor oil
Oil tank capacity	8½ ozs. / 250 ml
Carburetor	2133
Ignition system	C. D. I.
Spark plug	RCJ6Y
Oil feeding system	Automatic pump with adjuster
Chain type	. 325.058x76DL
Weight	18 lb / 8.2 kg
Guide bar type	BU20-76-5812P
Size	20" / 51 cm
Gauge	0.058" / 1.5 mm

NEED ASSISTANCE?

Call us on our toll free customer support line:

1-833-818-4111 - Monday through Friday, 9am - 5pm, Eastern Standard Time

- Technical questions
- Replacement parts
- Parts missing from package

TABLE OF CONTENTS



Product Specifications	1
Table of Contents	2
General Safety Warnings.....	3-4
Chainsaw Use and Care	4-5
Specific Safety Rules	5-7
Symbols	8
Know Your 20"Chainsaw	9
Handling Fuel	10
Operation	10
Installing Guide Bar and Saw Chain	11
Fuel and Oil	12
How to Mix Fuel	12
Operating the Engine	14
Checking Oil Supply	15
Adjusting the Carburetor	15
Chain Brake	16
Cutting a Tree.....	17
Bucking and Limbing	17
Maintenance	18-20
Troubleshooting	21
Exploded View	22
Parts List	23-27
Warranty	28

IMPORTANT!

SAFETY INSTRUCTIONS

ALL OPERATORS MUST READ THESE INSTRUCTIONS BEFORE USE

Any electrical appliance can be dangerous if used incorrectly. Some of the safety precautions given in this manual apply generally to many appliances. Other warnings are specific to the use of this chainsaw. Always follow these safety guidelines. Failure to do so may result in serious bodily injury or death.

SYMBOL	MEANING
 DANGER	This indicates a hazardous situation, which, if not followed, will result in serious injury or death.
 WARNING	This indicates a hazardous situation, which, if not avoided, could result in serious injury or death.
 CAUTION	This indicates a hazardous situation, which, if not avoided, could result in minor or moderate injury.

GENERAL SAFETY

FOR HOUSEHOLD USE ONLY

Before using, be sure that everyone using this tool reads and understands all safety instructions and other information contained in this manual. Save this manual and review it frequently prior to using this tool and when instructing others on the proper operating procedures.

 **CAUTION!** Wear appropriate hearing protection during use. After long periods of extended use, the noise generated from this appliance may cause hearing loss if your ears are not properly protected.

 **WARNING!** When using electric yard tools, basic safety precautions should always be followed to reduce the risk of fire, electric shock, and personal injury, including the following:

1. **Keep work area clean and well lit** - Cluttered or dark areas invite accidents.
2. **Replacement parts** - When servicing this unit, use only identical replacement parts.
3. **Keep children, bystanders and pets away** - All spectators, including pets, should be kept a safe distance away from the work area.
4. **Dress properly** - Do not wear loose clothing or jewelry as such articles can get caught in moving parts. Wear a protective covering to contain long hair. Wearing rubber gloves and substantial nonslip footwear is recommended when working outdoors.
5. **No smoking** - Never smoke while operating this unit.
6. **Not to be used by children** - Never allow children or anyone unable to fully understand the manual to use this unit.
7. **Ensure fuel cap is tightly closed** - Unit vibrations can cause an improperly tightened fuel cap to loosen or come off and spill fuel. In order to reduce risk of fuel spillage and fire, ensure the cap is tightened before each use.

8. **Toxic exhaust fumes** - The unit produces toxic exhaust fumes when the engine is running. These gases (carbon monoxide) may be colourless and odourless. To reduce the risk of serious or fatal injury from breathing toxic fumes, never run the unit indoors or in poorly ventilated locations.
9. **Moving parts** - This unit has a rotating impeller. Never perform any maintenance or assembly on this unit while the engine is running. Keep hands and feet away from moving parts. Keep guards in place and in proper working order.
10. **Wear personal protective equipment** - When using this tool, wear safety glasses with side shields or goggles to provide necessary eye protection. Wear ear protection to prevent hearing damage. Use a face or dust mask if the work environment is dusty.
11. **Do not force the tool** - It will perform better with less likelihood of personal or mechanical injury if it is used at the rate for which it is designed.
12. **Store idle tool indoors** - When not in use, the chainsaw should be stored indoors in a dry and high or locked-up place out of the reach of children.
13. **Maintain the chainsaw with care** - Keep the chainsaw clean for optimal performance and to reduce the risk of injury. Keep the handles dry, clean, and free from oil and grease. Follow the additional recommendations described in the maintenance section of this manual.
14. **Use care** - Do not direct the unit stream toward people or animals. Watch out for children, pets, open windows and blow debris safely away.
15. **Use the right tool** - Do not use the tool for any job except that for which it is intended.
16. **Avoid dangerous environments** - Do not use the chainsaw in rain, damp, or wet locations.
17. **Stay alert** - Watch what you are doing. Use common sense. Do not operate the chainsaw when you are tired or under the influence of drugs, alcohol, or other medication.

CHAINSAW USE AND CARE

Do not force the chainsaw. Use the correct chainsaw for your application. The correct chainsaw will do the job better and safer at the rate for which it was designed.

Do not use the chainsaw if the switch does not turn it on and off. Any chainsaw that cannot be controlled with the switch is dangerous and must be repaired.

Store idle chainsaws out of the reach of children and do not allow persons unfamiliar with the chainsaw or these instructions to operate the chainsaw. Chainsaws are dangerous in the hands of untrained users.

Maintain chainsaws. Check for misalignment or binding of moving parts, breakage of parts and any other condition that may affect the chainsaw's operation. If damaged, have the chainsaw repaired before use. Many accidents are caused by poorly maintained chainsaws.

Keep cutting tools sharp and clean. Properly maintained cutting tools with sharp cutting edges are less likely to bind and are easier to control.

Use the chainsaw, accessories and tool bits etc. in accordance with these instructions, taking into account the working conditions and the work to be performed. Use of the

chainsaw for operations different from those intended could result in a hazardous situation.

Hold power tools by insulated gripping surfaces when performing an operation where the cutting tool may contact hidden wiring or its own cord. Contact with a "live" wire will make exposed metal parts of the tool "live" and shock the operator.

SERVICE

Have your power tool serviced by a qualified repair person using only identical replacement parts. This will ensure that the safety of the power tool is maintained.

SPECIFIC SAFETY RULES

Keep all parts of the body away from the saw chain when the chainsaw is operating. Before you start the chainsaw, make sure the saw chain is not contacting anything. A moment of inattention while operating chainsaws may cause entanglement of your clothing or body with the saw chain.

NOTE: The size of the work area depends on the job being performed as well as the size tree or work piece involved. For example, felling a tree requires a larger work area when making buck cuts.

Always hold the chainsaw with your right hand on the rear handle and your left hand on the front handle. Holding the chainsaw with a reversed hand configuration increases the risk of personal injury and should never be done.

Hold the chainsaw by insulated gripping surfaces only, because the saw chain may contact hidden wiring. Saw chains contacting a live wire may make exposed metal parts of the chainsaw live and could give the operator an electric shock.

Wear safety glasses and hearing protection. Further protective equipment for head, hands, legs and feet must be worn. Adequate protective clothing will reduce personal injury by flying debris or accidental contact with the saw chain.

Do not operate a chainsaw in a tree. Operation of a chainsaw while up in a tree may result in personal injury.

Always keep proper footing and operate the chainsaw only when standing on fixed, secure and level surface. Slippery or unstable surfaces such as ladders may cause a loss of balance or control of the chainsaw.

When cutting a limb that is under tension be alert for springback. When the tension in the wood fibres is released the limb under tension may strike the operator and/ or throw the chainsaw out of control.

Use extreme caution when cutting brush and saplings. The slender material may catch the saw chain and be whipped toward you or pull you off balance.

Carry the chainsaw by the front handle with the chainsaw switched off and away from your body. When transporting or storing the chainsaw always fit the guide bar cover. Proper handling of the chainsaw will reduce the likelihood of accidental contact with the moving saw chain.

ALWAYS USE TWO HANDS WHEN OPERATING THE CHAINSAW

Contact of the guide bar tip with any object should be avoided.



Tip contact may cause the guide bar to move suddenly upward and backward, which may cause serious injury.

Follow instructions for lubricating, chain tensioning and changing accessories. Improperly tensioned or lubricated chain may either break or increase the chance for kickback.

Keep handles dry, clean, and free from oil and grease. Greasy, oily handles are slippery causing loss of control.

Cut wood only. Do not use chainsaw for purposes not intended. For example: do not use chainsaw for cutting plastic, masonry or non-wood building materials. Use of the chainsaw for operations different than intended could result in a hazardous situation.

⚠️ WARNING! Use the chainsaw, accessories and tool bits etc. in accordance with these instructions, taking into account the working conditions and the work to be performed. Use of the chainsaw for operations different from those intended could result in a hazardous situation.



CAUSES AND OPERATOR PREVENTION OF KICKBACK

⚠️ WARNING! Kickback may occur when the moving chain contacts an object at the upper portion of the tip of the guide bar or when the wood closes in and pinches the saw chain in the cut. Contact at the upper portion of the tip of the guide bar can cause the chain to dig into the object and stop the chain for an instant. The result is a lightning fast reverse reaction which kicks the guide bar up and back toward the operator. If the saw chain is pinched along the top of the guide bar, the guide bar can be driven rapidly back toward the operator. Either of these reactions can cause loss of saw control which can result in serious injury. Do not rely exclusively upon the safety devices built into the saw. As a chainsaw user, you should take several steps to keep your cutting jobs free from accident or injury.

Maintain a firm grip, with thumbs and fingers encircling the chainsaw handles, with both hands on the saw and position your body and arm to allow you to resist kickback forces. Kickback forces can be controlled by the operator, if proper precautions are taken. Do not let go of the chainsaw.

Do not overreach and do not cut above shoulder height. This helps prevent unintended tip contact and enables better control of the chainsaw in unexpected situations.

Only use replacement bars and chains specified by the manufacturer. Incorrect replacement bars and chains may cause chain breakage and/or kickback.

Follow the manufacturer's sharpening and maintenance instructions for the saw chain. Decreasing the depth gauge height can lead to increased kickback.

With a basic understanding of kickback, you can reduce or eliminate the element of surprise. Sudden surprise contributes to accidents.

⚠ATTENTION! It is recommended that first time user should practice cutting logs on a sawhorse or frame.

VIBRATION AND NOISE REDUCTION

To reduce the influence of vibration and noise, limit working hours and wear personal protective equipment. Observe the following points to minimize vibration and noise exposure:

1. Use the product only in accordance with its design and instructions.
2. Ensure that the product is in good condition and well maintained.
3. Use the correct accessories and ensure that they are in good condition.
4. Hold the product firmly but not tightly by the handles provided.
5. Maintain the product according to these instructions and keep it well lubricated.
6. Plan your working hours according to these instructions in order to spread a higher load over a longer period of time.

⚠WARNING! Familiarize yourself with the use of the product by reading this manual completely. Make a note of the safety instructions and follow them carefully. This will help you prevent risks and hazards.

Always be careful when using the product so that you can identify and react to hazards early. Quick intervention can prevent serious injury and property damage.

RESIDUAL RISKS

















Even if you operate this power tool correctly, there are always residual risks. The following hazards may occur in connection with the construction and design of this power tool:

- a) Injuries and material damage caused by flying parts.
- b) Hearing damage if you do not wear suitable hearing protection or use the power tool for a long period of time.
- c) Damage to health resulting from hand-arm vibrations if the power tool is used for an extended period of time or is not properly operated and maintained.

ADDITIONAL SAFETY RULES

- The chainsaw has been designed to cut trees, branches, lumber and should never be used to cut materials other than wood.
- When operating the unit, always be aware of your surroundings. People, children and pets should be kept at a safe distance away from work area.
- Be sure to secure the unit when transporting it.
- Never douse or squirt the unit with water or any other liquid. Clean the unit after each use as described in the cleaning and storage section.

SYMBOLS

	Read the user manual before using the machine.		Warning! Danger! Note!	
  	Whenever the tool is in use, safety goggles must be worn to safeguard against flying objects. Ear protectors, such as a soundproof helmet must be worn to protect the operator's hearing. If the operator is working in an area where there is a risk of falling objects, a safety helmet must also be worn.		Do not expose to rain.	
			Wear safety boots to protect against electric shock.	
			Wear gloves to protect your hands.	
			Warning! Kickback danger.	
	Gas mixture port.		Max: the oil flow increases. Min: the oil flow decreases.	
	Chainsaw oil port.		H L T	H: High position. L: Low position. T: Idle position.
	Turn the chainsaw to "I" to stop the engine.			
	To close the choke, pull out the choke knob.			
	Always use the chainsaw with two hands.			

KNOW YOUR 20" 52CC CHAINSAW

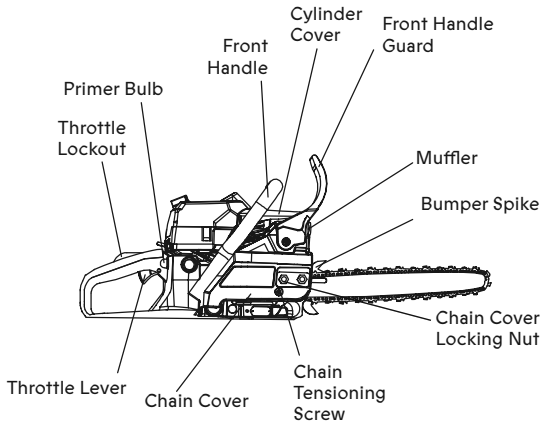
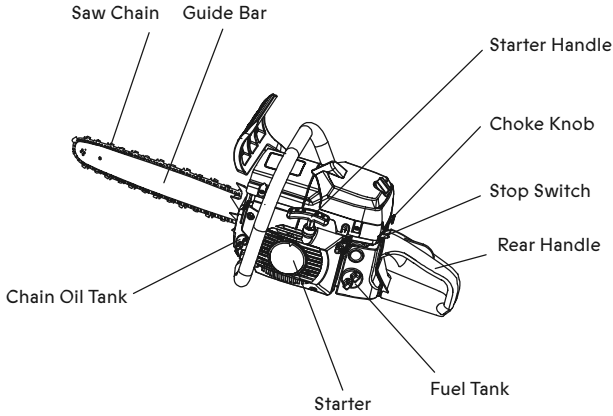

Bar and Chain Oil

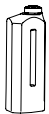

Fuel Mixing Container

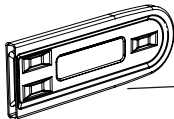

Chain Bar Cover

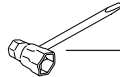

Combination Wrench



Hex Key

HANDLING FUEL

⚠️WARNING! The engine of this product is designed to run with mixed fuel which contains highly flammable gasoline. Never store cans of fuel or refill the fuel tank in any place where there is a boiler, stove, wood fire, electrical sparks, welding sparks, or any other source of heat or fire which might ignite the fuel.

Smoking while operating the product or refilling its fuel tank is extremely dangerous. Always be sure to keep lit cigarettes away from the product at all times.

Before refilling the tank always turn off the engine and take a careful look around to make sure that there are no sparks or open flames anywhere nearby.

If any fuel spillage occurs during refueling, use a dry rag to wipe up spills before turning the engine back on.

After refueling, screw the fuel cap tightly onto the fuel tank and then carry the product to a spot 10' / 3m or more away from where it was refueled before turning on the engine.

BEFORE STARTING ENGINE

Check your workspace, the cutting object and cutting direction. If there is an obstacle, remove it before starting to cut.

Never start until you have a clear work area, secure footing and a planned retreat path from a falling tree.

Use caution and keep bystanders and animals out of the working area and possible area around the cutting object.

Inspect the machine for worn, loose, or damaged parts. Never operate a machine that is damaged, improperly adjusted, or is not completely and securely assembled. Make sure that the saw chain stops moving when the throttle control trigger is released.

WHEN STARTING THE ENGINE

Always hold the machine firmly with both hands when the engine is running. Use a firm grip with thumb and fingers around the handles.

Keep all parts of your body away from the machine when the engine is running. Before starting the engine, make sure the saw's chain is not touching anything.

OPERATION

Keep the handles dry, clean and free of oil or fuel mixture.

Never touch the muffler, spark plug or other metal parts of the engine while the engine is in operation or immediately after stopping the engine. Doing so could result in serious burns or electrical shock.

Use extreme caution when cutting small sized brush and branches. Thin branches may catch the saw's chain and be whipped toward you or pull you off balance.

When cutting a limb that is under tension, be alert for spring back so that you will not be struck when the tension in the wood fibers is released.

Before starting check the tree for dead branches that could fall while you are working.

Always shut off the engine before setting it down.

INSTALLING GUIDE BAR AND SAW CHAIN

A standard saw unit package contains the following items (Figure 1):

1. Power unit
2. Chain bar cover
3. Guide bar
4. Saw chain
5. Combination wrench
6. Hex key

Install the guide bar and the chain on the power unit (Figure 2): Loosen the nuts and remove the chain cover.

Install the chain to the sprocket and while fitting the chain around the chain bar, mount the guide bar to the power unit.

Adjust the position of chain tension screw on the chain cover to the lower hole of chain bar.

- (1). Hole
- (2). Tensioner nut
- (3). Chain cover

NOTE: Pay attention to the correct direction of the chain (Figure 3).

Mount the guide bar to the studs of the power unit, and fit the chain around the guide bar. Adjust the position of the chain tension screw on the chain cover. Tighten the tension screw (Figure 4).

1. Tighten
2. Loosen
3. Tensioner screw

A new chain will expand its length in the beginning of use. Check and readjust the tension frequently as a loose chain can easily derail or cause rapid wear of itself and the guide bar.

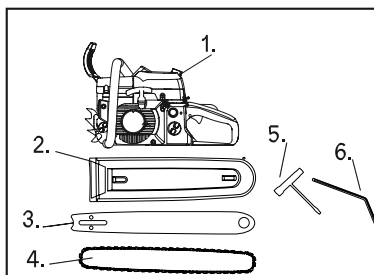

Figure 1

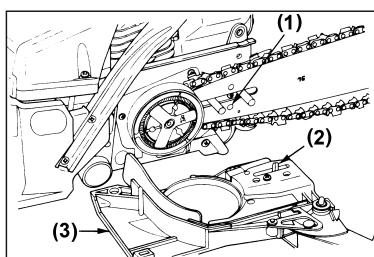

Figure 2

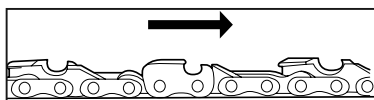

Figure 3

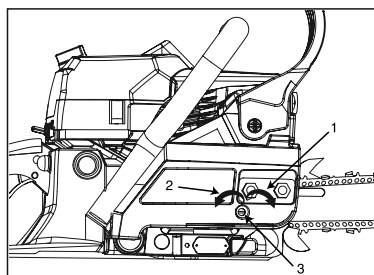

Figure 4

FUEL AND OIL

⚠️WARNING! Gasoline is very flammable. Avoid smoking or flames near fuel. Make sure to stop the engine and allow it to cool before refueling the unit. Fuel up on outdoor bare ground and move at least 10' / 3m away from the fueling point before starting the engine.

Please use an antioxidant added quality oil expressly labeled for air-cooled 2-cycle engine use.

Do not use 2-stroke water-cooling type mixed oil.

Exhaust emission are controlled by the fundamental engine parameters and components (carburetion, ignition timing and port timing) without addition of any major hardware or the introduction of an inert material during combustion.

This engine is certified to operate on unleaded gasoline.

Make sure to use gasoline with a minimum octane number of 87 (Regular). If you use a gasoline of a lower octane value than prescribed, there is a danger that the engine temperature may rise and an engine problem such as piston seizing may consequently occur.

Poor quality gasoline or oils may damage seal rings, fuel lines or fuel tank of the engine.

HOW TO MIX FUEL

FUEL MIXTURE

⚠️CAUTION! The machine is equipped with a two-stroke engine and must always be run using a mixture of petrol and two-stroke engine oil. It is important to accurately measure the amount of oil to be mixed to ensure that the correct mixture is obtained. When mixing small amounts of fuel, even small inaccuracies can drastically affect the ratio of the mixture.

⚠️WARNING! Always ensure there is adequate ventilation when handling fuel.

FUEL

⚠️CAUTION! Always use a good quality gasoline/oil mixture. When working at continuous high revolutions, a higher octane rating is recommended.

Gasoline with up to 10% ethanol is acceptable.

TWO-STROKE OIL

For best results and performance, use a good quality two-stroke oil that is intended for air cooled engines. Mixture 1:50 (2%).

Never use two-stroke oil intended for water-cooled outboard engines, sometimes referred to as outboard oil.

Never use oil intended for four-stroke engines.

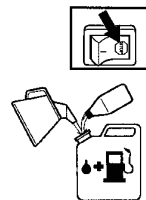

GAS-LITER	TWO-STROKE OIL· LITER (2% / 1:50)
1	0.02
2	0.04
3	0.06
4	0.08

MIXING

Always mix the gasoline and oil in a clean container intended for fuel.

Always start by filling half the amount of the gasoline to be used. Then add the entire amount of oil. Mix (shake) the fuel mixture. Add the remaining amount of gasoline.

Mix (shake) the fuel mixture thoroughly before filling the machine's fuel tank.

Do not mix more than one month's supply of fuel at a time. If the machine is not used for some time, the fuel tank should be emptied and cleaned.

⚠️WARNING! The catalytic converter muffler gets very hot during and after use. This also applies during idling. Be aware of the fire hazard, especially when working near flammable substances and/or vapors.

⚠️WARNING! Taking the following precautions, will lessen the risk of fire: Do not smoke or place hot objects near fuel. Always shut off the engine before refueling. Always stop the engine and let it cool for a few minutes before refueling. When refueling, open the fuel cap slowly so that any excess pressure is released gently. Tighten the fuel cap carefully after refueling. Always move the machine away from the refueling area before starting.

CHAIN OIL

⚠️CAUTION! Before starting the saw, remove the oil tank cap and add bar and chain oil.

NOTE!

1. The service life of saw chains and guide bars depends to a large extent on the quality of the lubricant used.
2. Old oil must not be used! Use only environment friendly chain lubricant.
3. Store chain lubricant only in containers which comply with the regulations.
4. Use 10W30 motor oil all year round, or 10W30 or 10W40 in the summer and 10W20 in the winter.

OPERATING THE ENGINE

STARTING THE ENGINE

Fill fuel and chain oil tanks and tighten the caps securely (Figure 5).

COLD ENGINE START

Move the front hand guard fully rearward (A) (towards the front handle) to unlock chain brake, listen for audible click as sign chain brake is unlocked. Press the primer bulb (B) 10 times, until the fuel begins to fill the bulb. The primer bulb does not need to be completely filled (Figure 6).

Put the switch to ON position (Figure 7).

Pull out the choke knob to the second-stage position (Figure 8). The choke will close and the throttle lever will then be set in the starting position (Figure 9).

Pull the starter to start the engine.

While holding the saw unit securely on the ground, pull the starter rope vigorously (Figure 10).

!WARNING! Do not start the engine while holding the chainsaw just in your hands. Be sure you have stabilized the saw before starting.

After the engine has ignited, push in the choke knob and pull the starter again to start the engine.

Allow the engine to warm up with the throttle lever pulled slightly. Once the throttle lever is pulled out, the choke knob is automatically in the operating position.

!WARNING! Keep clear of the saw chain as it will start rotating upon starting of engine.

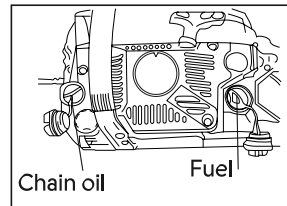

Figure 5

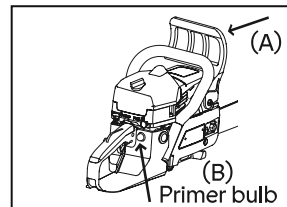

Figure 6

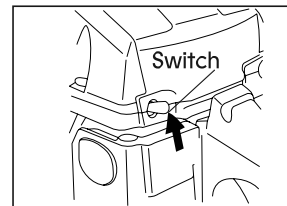

Figure 7

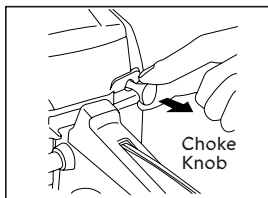

Figure 8

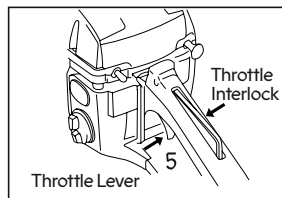

Figure 9

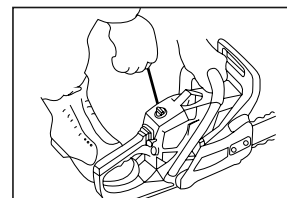

Figure 10

CHECKING OIL SUPPLY

After starting the engine, run the chain at medium speed and see if chain oil scatters as shown (Figure 11). Tighten cap if necessary.

1. Chain oil (Figure 11).
2. Chain oil port (Figure 12).

ADJUSTING THE CARBURETOR

The carburetor on your unit has been adjusted by the factory, but may require fine tuning due to changes in operating conditions.

Before adjusting the carburetor, make sure that you have clean air/fuel filters and fresh, properly mixed fuel.

When adjusting, take the following steps:

Turn the engine off and screw in both H and L needle jets until they stop. Never force. Then set them back the initial number of turns as show below.

H needle jet: 1 3/8 rotations out (Figure 13).

L needle jet: 1 1/4 rotations out (Figure 13).

Start engine and allow it to warm up at half-throttle.

Turn L needle jet slowly clockwise to find a position where idling speed is maximum, then set the needle back a 1/4 turn counterclockwise.

Turn idle adjusting screw counterclockwise so that saw chain does not turn. If idling speed is too slow, turn the screw clockwise (Figure 13).

Make a test cut and adjust the H needle jet for best cutting power, not for maximum speed.

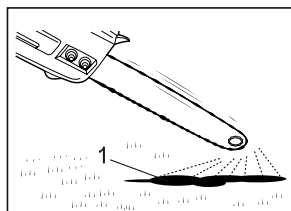

Figure 11

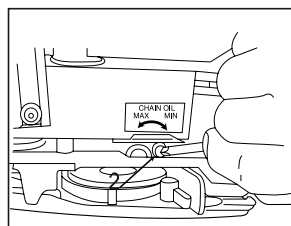

Figure 12

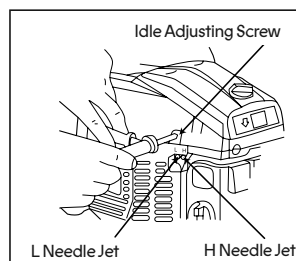

Figure 13

CHAIN BRAKE

To release the brake, pull the front guard up toward the front handle till "click" sound is heard (Figure 14).

1. Break
2. Released
3. Operated

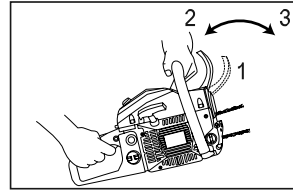

Figure 14

STOPPING THE ENGINE

1. Release the throttle lever to allow the engine to idle for a few minutes.
2. Put the switch to the stop position (Figure 15).

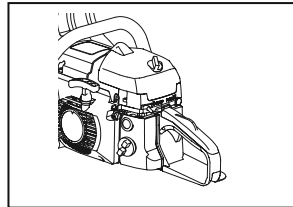

Figure 15

SAWING

⚠️WARNING! It is not necessary to force the saw into the cut. Apply only light pressure while running the engine at full throttle.

When the saw chain is caught in the cut, do not force it out. Use a wedge or a lever to open the way.

GUARD AGAINST KICKBACK

(Figure 16)

This saw is equipped with a chain brake that will stop the chain in the event of a kickback if operating properly. You must check the chain brake operation before each usage by running the saw at full throttle for 1-2 seconds and pushing the front hand guard forward.

The chain should stop immediately with the engine at full speed. If the chain is slow to stop or does not stop, replace the brake band and clutch drum before use.

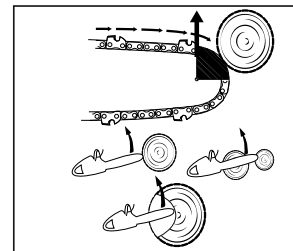

Figure 16

The chain should stop immediately with the engine at full speed. If the chain is slow to stop or does not stop, replace the brake band and clutch drum before use.

It is extremely important that the chain brake be checked for proper operation before each use and that the chain be sharp in order to maintain the kickback safety.

Removal of the safety devices, inadequate maintenance, or incorrect replacement of the bar or chain may increase the risk of serious personal injury due to kickback.

CUTTING A TREE

Decide the direction you want the tree to fall. Consider the wind, lean of the tree, location of heavy branches, ease of job after the tree falls, etc.

While cleaning the area around the tree, arrange a good foothold and retreat path.

Cut a notch into approximately one-third the width of the tree trunk, into the side of the tree in the direction you want it to fall (Figure 17).

Then cut from the opposite side of the notch and at a level slightly higher than the bottom of the notch (Figure 17).

⚠️WARNING! Before you cut a tree down, be sure to eliminate any dangers and notify those in close proximity.

BUCKING AND LIMBING

⚠️WARNING! Always ensure stable footing. Do not stand on the log. Be alert that the log may roll over after cutting. Especially when working on a slope, stand on the uphill side of the log. Follow the instructions in "For Safe Operation" to avoid kickback of the saw.

A LOG LYING ON THE GROUND

Saw down halfway, then roll the log over and cut from the opposite side (Figure 18).

A LOG HANGING OFF THE GROUND

In area A, saw up from the bottom one-third and finish by sawing down from the top. In area B, saw down from the top one-third and finish by sawing up from the bottom (Figure 19).

CUTTING LIMB OF A FALLEN TREE

First check to which side the limbs bent. Then make the initial cut from the bent side and finish by sawing from the opposite side. (Figure 20).

PRUNING A STANDING TREE

Cut up from the bottom, finish down from the top. Finish by sawing down from the top (Figure 21).

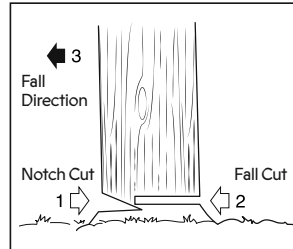

Figure 17

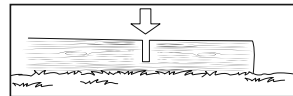

Figure 18

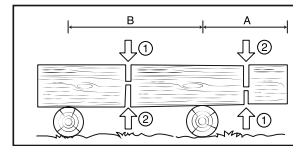

Figure 19

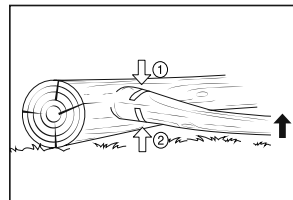

Figure 20

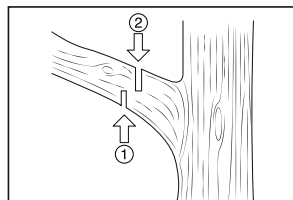

Figure 21

MAINTENANCE

⚠️ WARNING! Before cleaning, inspecting or repairing your unit, make sure that engine has stopped and is cool.

Disconnect the spark plug to prevent accidental starting.

MAINTENANCE AFTER EACH USE

AIR FILTER

To clean dirt in the filter, split the cleaner into halves and brush in gasoline. When using compressed air, blow from the inside (Figure 22).

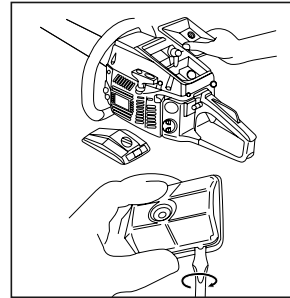

Figure 22

OIL PORT

Dismount the guide bar and check the oil port for clogging (Figure 23).

1. Oil port

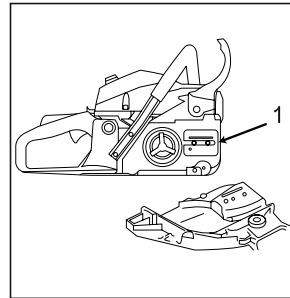

Figure 23

CHAIN BAR

When the chain bar is dismounted, remove sawdust in the bar groove and the oiling port. Grease the nose sprocket from the feeding port on the tip of the bar (Figure 24-25).

1. Oil port
2. Grease port
3. Sprocket

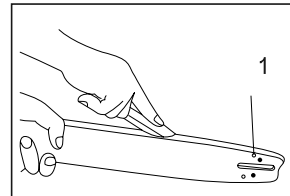

Figure 24

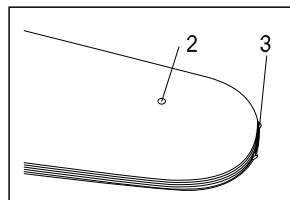

Figure 25

PERIODIC MAINTENANCE

CYLINDER FINS

Dust clogging between the cylinder fins will cause overheating of the engine. Periodically check and clean the cylinder fins after removing the air cleaner and the cylinder cover.

NOTE: Be sure to block the air intake hole (Figure 26).

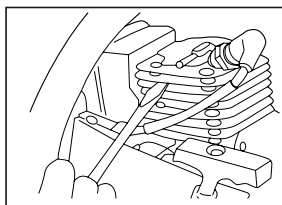

Figure 26

FUEL FILTER

Using a wire hook, take out the filter from the filler port. Disassemble the filter and wash with gasoline (Figure 27).

NOTE: After removing the filter, use a pinch to hold the end of the suction pipe, take care not to allow filters or dust inside the suction pipe.

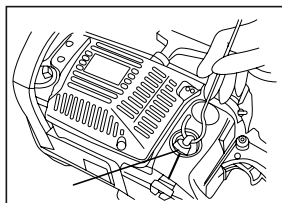

Figure 27

OIL TANK

With a wire hook, take out the oil filter through the filler port and clean with gasoline. When putting the filter back into the tank, make sure that it comes to the front right corner. Also clean off dirt in the tank. (Figure 28).

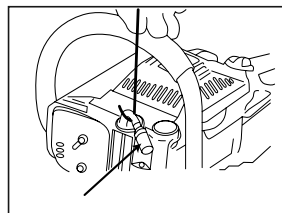

Figure 28

SPARK PLUG

Clean the electrodes with a wire brush and reset the gap to 0.6~0.7 mm as necessary (Figure 29).

SPROCKET

Check for cracks and excessive wear interfering with the chain drive. If obvious wearing is found, replace the sprocket with new one. Never fit a new chain on worn sprocket, or a worn chain on a new sprocket.

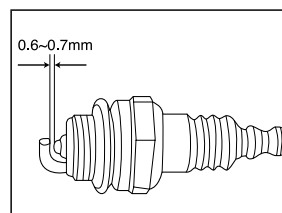

Figure 29

MAINTENANCE OF SAW CHAIN AND GUIDE BAR

SAW CHAIN

⚠️WARNING! It is very important for smooth and safe operation to keep the chain sharp.

Your chain needs to be sharpened when:

- Sawdust becomes powder-like.
- You need extra force to saw.
- The cut way does not go straight.
- Vibration increases.
- Fuel consumption increases.

Chains standards:

- Make sure the saw chain is held securely.
- Make sure the engine is stopped.
- Use a round file of proper size for your chain.

Place your file on the chain and push straight forward. Keep the file position as illustrated (Figure 30).

After every cutter has been set, check the depth gauge and file it to the proper level (Figure 30).

⚠️WARNING! Be sure to round off the front edge to reduce the chance of kickback or tie/ strap breakage (Figure 31).

1. Appropriate gauge checker.
2. Make the shoulder round.
3. Depth gauge standard. Make sure every cutter has the same length and edge angles (Figure 32).
4. Cutter length.
5. Filing angle.
6. Side plate angle.
7. Top plate cutting angle.

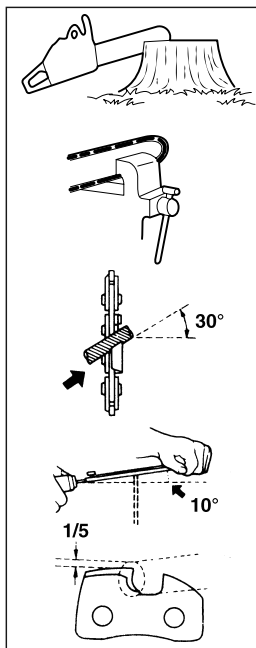

Figure 30

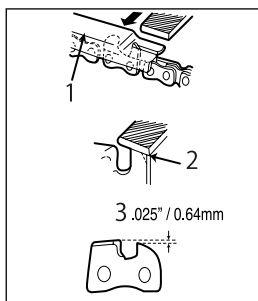

Figure 31

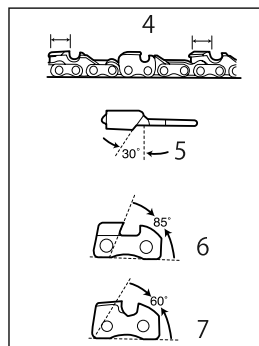

Figure 32

GUIDE BAR

Reverse the bar occasionally to prevent partial wear.

TROUBLESHOOTING

1. STARTING FAILURE

PROBLEM	POSSIBLE CAUSE	SOLUTION
Starting failure.	<ol style="list-style-type: none"> 1. Check fuel for water or substandard mixture. 2. Check for engine flooding. 3. Check the spark plug. 	<ol style="list-style-type: none"> 1. Replace with proper fuel. 2. Remove and dry the spark plug. Then pull the starter again without the choke. 3. Replace with a new spark plug.

2. LACK OF POWER/POOR ACCELERATION/ROUGH IDLING

PROBLEM	POSSIBLE CAUSE	SOLUTION
Lack of power/ poor acceleration/ rough idling.	<ol style="list-style-type: none"> 1. Check fuel for water or substandard mixture. 2. Check air filter and fuel filter for clogging. 3. Check carburetor for inadequate adjustment. 	<ol style="list-style-type: none"> 1. Replace with proper fuel. 2. Clean. 3. Readjust jet needles.

3. OIL DOES NOT COME OUT

PROBLEM	POSSIBLE CAUSE	SOLUTION
Oil does not come out.	<ol style="list-style-type: none"> 1. Check oil for substandard quality. 2. Check oil passage and ports for clogging. 	<ol style="list-style-type: none"> 1. Replace with new oil. 2. Clean.

EXPLODED VIEW

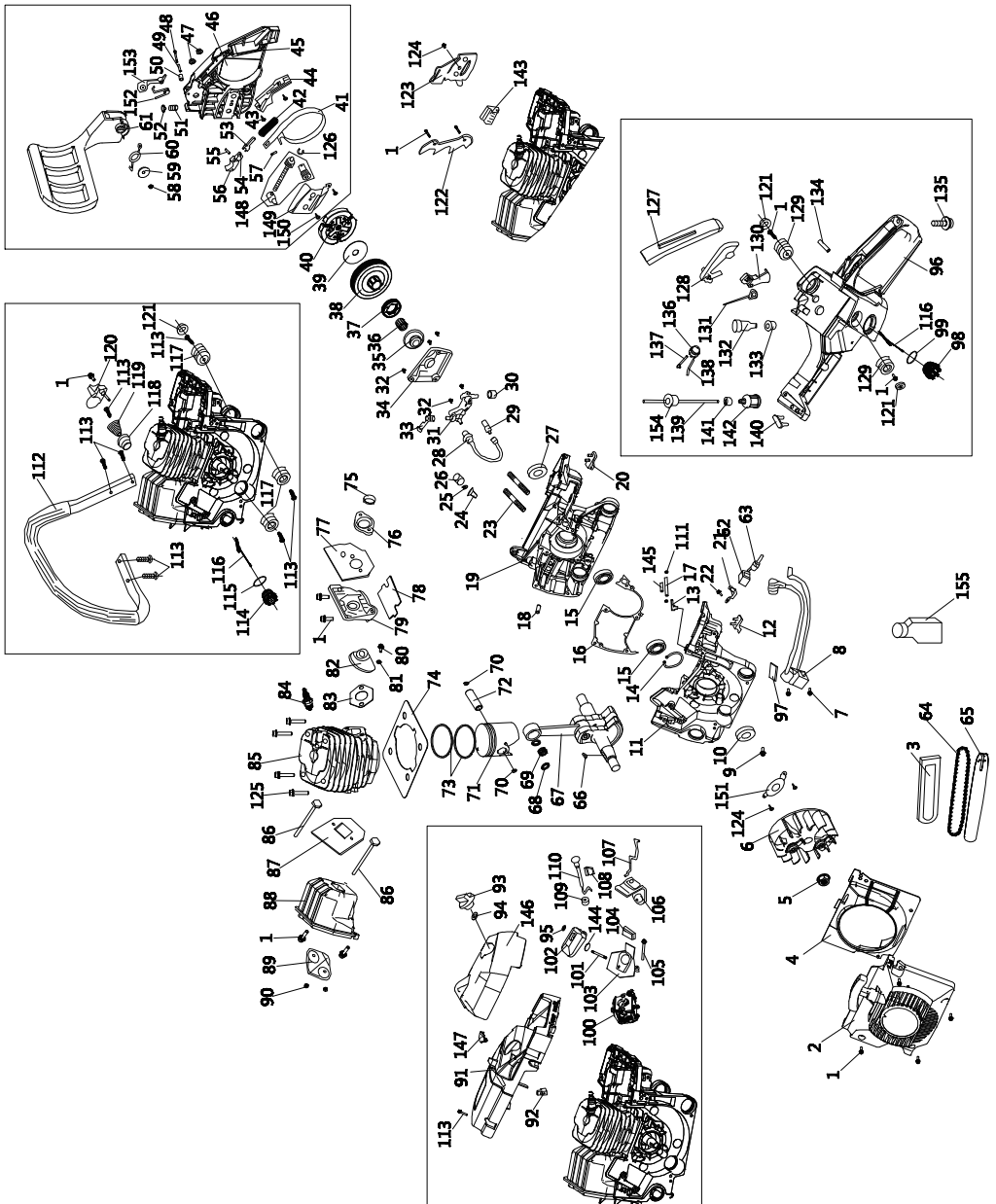

PARTS LIST

⚠️WARNING! When servicing, use only original equipment replacement parts. The use of any other parts may create a safety hazard or cause damage to the 20" 52cc chainsaw. Any attempt to repair or replace electrical parts on this 20" chainsaw may create a safety hazard unless repairs are performed by a qualified technician. For more information, call the Toll-free Helpline, at 1-833-818-4111 - Monday-Friday, from 9am - 5pm, Eastern Standard Time.

Always order by PART NUMBER, not by key number.

Key #	Part #	Part Name	Quantity
1	1855ZA0001	SCREW ASSEMBLY	18
2	1855ZA0002	STARTER ASSEMBLY	1
3	1855ZA0003	CHAIN COVER	1
4	1855ZA0004	STARTER INNER COVER	1
5	1855ZA0005	NUT M8*1	1
6	1855ZA0006	MAGNETO ROTOR	1
7	1855ZA0007	HEXAGON SCREW	2
8	1855ZA0008	MAGNETO STARTER	1
9	1855ZA0009	SCREW M5*30	5
10	1855ZA0010	OIL SEAL 15*34*4.5	1
11	1855ZA0011	LEFT BOX	1
12	1855ZA0012	RUBBER WASHER	1
13	1855ZA0013	CONNECTOR	1
14	1855ZA0014	HOLE CIRCUIT	1
15	1855ZA0015	BEARING	2
16	1855ZA0016	SEALANT WASHER	1
17	1855ZA0017	VACUUM TUBE	1
18	1855ZA0018	PIN	2
19	1855ZA0019	RIGHT BOX	1
20	1855ZA0020	RUBBER WASHER	1
21	1855ZA0021	GROUND STRIP	1
22	1855ZA0022	SCREW	1
23	1855ZA0023	STUD	2
24	1855ZA0024	INLET VALVE	1
25	1855ZA0025	PISTON PIN RING	1
26	1855ZA0026	FOAM	1
27	1855ZA0027	OIL SEAL 12*28*4.5	1
28	1855ZA0028	INLET GREASE PIPE	1
29	1855ZA0029	CHAIN OIL FILTER	1

Key #	Part #	Part Name	Quantity
30	1855ZA0030	FOAM	1
31	1855ZA0031	OIL PUMP	1
32	1855ZA0032	SCREW ASSEMBLY M4*16	5
33	1855ZA0033	OUTLET OIL PUMP	1
34	1855ZA0034	OIL PUMP COVER	1
35	1855ZA0035	SCREW PLUG	1
36	1855ZA0036	NEEDLE BEARING 12*15*14	1
37	1855ZA0037	CHAIN WHEEL 7T0.325	1
38	1855ZA0038	CLUTCH DRUM	1
39	1855ZA0039	CLUTCH WASHER	1
40	1855ZA0040	CLUTCH	1
41	1855ZA0041	ARRESTER	1
42	1855ZA0041	SPRING	1
43	1855ZA0043	SELF SCREW	2
44	1855ZA0044	SPRING COVER	1
45	1855ZA0045	PLATE	1
46	1855ZA0046	COVER	1
47	1855ZA0047	NUT	2
48	1855ZA0048	SCREW ASSEMBLY	1
49	1855ZA0049	HANDLE STEEL SLEEVE	1
50	1855ZA0050	PLASTIC SHAFT SLEEVE	1
51	1855ZA0051	SPRING	1
52	1855ZA0052	SPRING WASHER	1
53	1855ZA0053	SPRING PUSH ROD	1
54	1855ZA0054	LEVER	1
55	1855ZA0055	ROUND PIN	1
56	1855ZA0056	LEVER	1
57	1855ZA0057	PIN	3
58	1855ZA0058	NUT	1
59	1855ZA0059	WASHER	1
60	1855ZA0060	BRAKE TORSION SPRING	1
61	1855ZA0061	BRAKE HANDLE	1
62	1855ZA0062	SWITCH RUBBER SLEEVE	1
63	1855ZA0063	ENGINE SWITCH	1
64	1855ZA0064	CHAIN	1
65	1855ZA0065	BAR	1

Key #	Part #	Part Name	Quantity
66	1855ZA0066	KEV 3*3.7*10	1
67	1855ZA0067	CRANKSHAFT CONNECTING ROD	1
68	1855ZA0068	WASHER	2
69	1855ZA0069	NEEDLE BEARING	1
70	1855ZA0070	PISTON PIN RING	2
71	1855ZA0071	PISTON	1
72	1855ZA0072	PISTON PIN	1
73	1855ZA0073	PISTON RING	2
74	1855ZA0074	CYLINDER WASHER	1
75	1855ZA0075	CLUTCH WASHER	1
76	1855ZA0076	INLET PIPE	1
77	1855ZA0077	PAPER BOARD	1
78	1855ZA0078	PAPER BOARD	1
79	1855ZA0079	CARBURETOR WASHER	1
80	1855ZA0080	SCREW	2
81	1855ZA0081	PLATE WASHER	2
82	1855ZA0082	RUBBER INLET OIL PIPE	1
83	1855ZA0083	INLET PIPE WASHER	1
84	1855ZA0084	SPARK PLUG	1
85	1855ZA0085	CYLINDER	1
86	1855ZA0086	NUT	2
87	1855ZA0087	MUFFLER WASHER	1
88	1855ZA0088	MUFFLER (WITH CATALYST)	1
89	1855ZA0089	MUFFLER WASHER	1
90	1855ZA0090	NUT	2
91	1855ZA0091	CYLINDER COVER	1
92	1855ZA0092	IDLE SCREW RUBBER SLEEVE	1
93	1855ZA0093	LOCK SCREW	1
94	1855ZA0094	WASHER	1
95	1855ZA0095	LOCK SCREW	1
96	1855ZA0096	FRAME WELDED	1
97	1855ZA0097	STARTER INNER RUBBER	1
98	1855ZA0098	OIL CAP	1
99	1855ZA0099	WASHER	1
100	1855ZA0100	CARBURETOR	1
101	1855ZA0101	NUT	1

Key #	Part #	Part Name	Quantity
102	1855ZA0102	AIR FILTER ASSEMBLY	8
103	1855ZA0103	CARBURETOR CONNECTOR	1
104	1855ZA0104	RUBBER WASHER	1
105	1855ZA0105	SCREW	2
106	1855ZA0106	RUBBER WASHER	3
107	1855ZA0107	THROTTLE LEVER	1
108	1855ZA0108	RUBBER WASHER	1
109	1855ZA0109	CHOKE VALVE WASHER	1
110	1855ZA0110	CHOKE VALVE	5
111	1855ZA0111	CLIP	1
112	1855ZA0112	LEFT HANDLE	1
113	1855ZA0113	SELF SCREW	3
114	1855ZA0114	ENGINE OIL CAP	4
115	1855ZA0115	WASHER	1
116	1855ZA0116	ANTI KICKBACK CHAIN	1
117	1855ZA0117	RUBBER PLUG	1
118	1855ZA0118	SPRING WASHER	2
119	1855ZA0119	SPRING	1
120	1855ZA0120	SPRING PLATE	1
121	1855ZA0121	CAP	1
122	1855ZA0122	COG	1
123	1855ZA0123	CHAIN PLATE	1
124	1855ZA0124	SCREW	1
125	1855ZA0125	SCREW	1
126	1855ZA0126	WORM SHAFT O RING	1
127	1855ZA0127	RIGHT HANDLE UPPER CAP	1
128	1855ZA0128	ROD	1
129	1855ZA0129	RUBBER PLUG	1
130	1855ZA0130	OIL HANDLE	1
131	1855ZA0131	SPRING	1
132	1855ZA0132	AIR FILTER	1
133	1855ZA0133	OIL TANK INTAKE PIPE GASKET	1
134	1855ZA0134	THROTTLE HANDLE SHAFT	1
135	1855ZA0135	SCREW	1
136	1855ZA0136	PUMP	1
137	1855ZA0137	FUEL OIL PIPE	1

Key #	Part #	Part Name	Quantity
138	1855ZA0138	OIL OUTLET PIPE BLACK	1
139	1855ZA0139	OIL INLET PIPE BLACK	1
140	1855ZA0140	RUBBER WASHER	1
141	1855ZA0141	STEEL SLEEVE	1
142	1855ZA0142	AIR FILTER	1
143	1855ZA0143	PLASTIC WASHER	1
144	1855ZA0144	O WASHER	1
145	1855ZA0145	HEAT SLEEVE	1
146	1855ZA0146	AIR FILTER COVER	1
147	1855ZA0147	RUBBER WASHER	1
148	1855ZA0148	CLUTCH ASSEMBLY	1
149	1855ZA0149	CHAIN PLATE	1
150	1855ZA0150	SCREW	2
151	1855ZA0151	OIL SEAL PLATE	1
152	1855ZA0152	SPRING	1
153	1855ZA0153	ROCKER	1
154	1855ZA0154	FUEL PIPE GASKET	1

WARRANTY**RADLEY 20" 52CC CHAINSAW**

If this Radley tool fails due to a defect in material or workmanship within three years from the date of purchase, it has a **three-year repair warranty with the original bill of sale**. This warranty does not include expendable parts including but not limited to blades, brushes, belts, light bulbs and/or batteries. This warranty covers defects in material or workmanship only. It does not cover normal wear and tear, failure due to abuse/misuse, or defects caused by careless or accidental mishandling. If this Radley product is used for commercial or rental purposes, this warranty does not apply.

20" 52CC CHAINSAW

OWNER'S MANUAL



3 Year Limited Warranty on tool

Radley®

RADLEY TOOLS
ST. JACOBS, ONTARIO N0B 2N0
© 2021 Home Hardware Stores Limited
1-833-818-4111
Customer Service/Tech Support

5240-174

Made in China

**3 Year
warranty**

This Radley® product carries a three (3) year LIMITED warranty against defects in workmanship and materials. See Owner's Manual for full details.



**READ ALL INSTRUCTIONS BEFORE FIRST USE.
KEEP THIS MANUAL FOR FUTURE REFERENCE.
KEEP AWAY FROM CHILDREN.**



**WEAR CSA APPROVED
EYE PROTECTION**



**WEAR EAR
PROTECTION**



**WEAR FACE
PROTECTION**