

BENCHMARK™

BG2300Di



MANUAL



This product is supported by **Midland Power**. Contact us directly for assistance and warranty help. Do not return this product to store.

You must register online for your warranty to be valid. It only takes a minute, do it now while you still have your purchase receipt.

Register Your Product Online

[www.benchmark.midlandpowerinc.com/
register-warranty](http://www.benchmark.midlandpowerinc.com/register-warranty)



Support for your product is available online, including parts, service center locations, and live expert advice.

Visit us online at

www.benchmark.midlandpowerinc.com



Or call us anytime at **1-877-528-3772**.

Thanks for choosing the BG2300Di!

You're excited to get started, we'll keep this brief.

READ THIS ENTIRE GUIDE BEFORE USING THIS PRODUCT AND SAVE FOR LATER USE.

This user guide contains important instructions including safety, setup, operation, and maintenance that must be followed. All information in this guide is based on information available at the time of print. This guide or revised editions can be found on our website for download. No part of this publication may be reproduced without written permission.



THIS PRODUCT MEETS ALL CERTIFICATION REQUIREMENTS FROM:



The engine exhaust from this product contains chemicals known to cause cancer, birth defects or other reproductive harm.



©2023 Benchmark. All Rights Reserved.

BG2300Di_Manual_EN_2023-08-14

TABLE OF CONTENTS

1. Safety	1
2. Learn About Your Generator	5
3. Pre-Operation Check	9
3.1 Add Oil	9
3.2 Check the Air Filter	11
3.3 Add Fuel (Gasoline Only)	12
3.4 Check the LP Gas Cylinder Connection (Propane Only)	13
4. Starting the Engine	14
4.1 Starting your Dual Fuel Generator	15
4.2 Gasoline Manual Recoil Start	16
4.3 Propane (LPG) Manual Recoil Start	17
5. Generator Use	18
5.1 Output, Overload, and Oil Alert Indicator	18
5.2 DC Applications	19
5.3 AC Applications	20
5.4 AC Parallel Operation	21
5.5 Extending the Handle	22
6. Stopping the Engine	23
7. Maintenance	24
7.1 Maintenance Schedule	25
7.2 Changing the Oil	26
7.3 Cleaning the Air Filter	28
7.4 Spark Plug Service	29
7.5 Spark Arrester Maintenance	30
7.6 Fuel Filter Maintenance	31
7.7 Carburetor Modification for High Altitude Operation	32
7.8 Emission Control System	34
8. Transportation & Storage	36
9. Troubleshooting	38
10. Technical Specifications	40
11. Wiring Diagram	41
12. Appendix	42
13. Limited Warranty	43

1. SAFETY

⚠ DANGER	
Using a generator indoors CAN KILL YOU IN MINUTES . Generator exhaust contains carbon monoxide. This is a poison you cannot see or smell.	
 NEVER use inside a home or garage, EVEN IF doors and windows are open.	 Only use OUTSIDE and far away from windows, doors, and vents.
Avoid other generator hazards. READ MANUAL BEFORE USE.	

⚠ WARNING!

This product can expose you to chemicals including carbon monoxide, which is known to the State of California to cause cancer and birth defects or other reproductive harm. For more information go to www.P65Warnings.ca.gov

1.1 OPERATOR SAFETY

⚠ WARNING!

- Always perform an oil, fuel and air filter check before starting the engine.
- Properly clean and maintain the equipment.
- Operate the generator according to instructions for safe and dependable service.
- Before operating the generator, read the user guide carefully. Otherwise, personal injuries or equipment damage may result.
- Never run the generator in an enclosed area to avoid harm from exhaust emissions of a poisonous carbon monoxide gas.
- Pay attention to the warning labels. The engine exhaust system will become heated during operation and remain hot immediately after the engine is stopped.
- Gasoline is a highly flammable and explosive liquid. Refuel in a well ventilated area with the engine stopped.
- Use of gasoline with an ethanol content greater than 10% can damage the engine and fuel system and will void the manufacturer's warranty.
- When refueling the generator, keep it away from cigarettes, open flames, smoke and/or sparks.
- Place the generator at least 3 feet away from buildings or other

equipment during operation.

- Run the generator on a level surface. Tilting the generator may result in fuel spills.
- Do not touch the spark plug while the engine is operating or shortly after the engine has been shut down.
- Know how to stop the generator quickly and understand operation of all the controls. Never permit anyone to operate the generator without proper instructions.
- Keep children, pets and machinery with rotating parts away during operation.
- Do not operate the generator in rain or snow.
- Do not allow any moisture to come in contact with the generator.

1.2 AC SAFETY

WARNING!

Before connecting the generator to an electrical device or power cord:

- Make sure that everything is in proper working order. Faulty devices or power cords can lead to an electrical shock.
- Turn off the generator immediately if the device begins to operate abnormally. Then disconnect the device and investigate the problem.
- To prolong engine life, do not exceed the rated running wattage.
- Keep away from other electric cables or wires.
- Make sure that the electrical rating of the device does not exceed that of the generator. If the power level of the device is between the maximum output power and the running power of the generator, the generator should not be used for more than 30 minutes.
- When an extension cable is required, be sure to use a tough rubber sheathed flexible cable (according to IEC245 or equivalent standards). The maximum length of the extension cable: 196 feet (60 meters) for cable of 15.5 gauge (1.5mm²); 328 feet (100 meters) for cable of 13.25 gauge (2.5mm²).
- Connections for standby power to a building's electrical system must be done by a qualified electrician and must comply with all applicable laws and electrical codes. Improper connections may cause serious injuries to electrical workers during a power outage, and when the utility power is restored, the generator may explode or cause fires. The generator shall be connected through transfer equipment that switches all conductors other than the equipment grounding conductor. The

frame of the generator shall be connected to an approved grounding electrode.

- For power outages, permanently installed stationary generators are better suited for providing backup power to the home. Even a properly connected portable generator can become overloaded. This may result in overheating or stressing the generator components, possibly leading to a generator failure.
- This unit is floating neutral. The generator (stator winding) is isolated from the frame and from the AC receptacle ground pin.
- Electrical devices that require a grounded receptacle pin connection will not function if the receptacle ground pin is not functional.

1.3 PROPANE SAFETY

⚠ WARNING!

- Propane is a Liquid Petroleum Gas (LPG) which is highly flammable and explosive.
- Do not store or use LPG in an enclosed area.
- Do not expose the LPG cylinder to excessive heat.
- Fully close the LPG cylinder when the generator is not in use or is running with gasoline.
- Never use a gas container, LPG connector hose, LPG cylinder or any other fuel item that appears damaged.
- If you smell gas, close the gas supply and check all connections for leaks before attempting to use the generator again.
- Keep the LPG cylinder in an upright position.
- Keep a fire extinguisher near the generator all the time.

1.4 MAINTENANCE SAFETY

⚠ WARNING!

- After any maintenance is performed, wash immediately using soap and clean water. Repeated exposure to lubricant may cause skin irritation.
- Do not clean the filter element with flammable liquids like gasoline because an explosion may occur.
- Allow the generator set to cool down and turn off the engine before performing any maintenance. Failure to do so can cause severe personal injury or death.
- Always wear safety glasses when cleaning the generator set with air.
- Do not clean the generator set with a pressure washer because it can

damage the generator set.

- When working with batteries, ventilate the area, use safety glasses, do not smoke. Always disconnect the negative first and reconnect it last.
- Use rubber gloves when coming into contact with engine oil.
- Always stop the generator set before removing the oil filler cap.
- Only qualified maintenance personnel with knowledge of fuels, electricity, and machinery hazards should perform maintenance procedures.

1.5 OTHER SAFETY TIPS

⚠ WARNING ⚠
AVERTISSEMENT



TOXIC FUMES HAZARD. Running engines give off carbon monoxide, an odourless poisonous gas that can cause nausea, fainting, or death. Do not start engine indoors or in an enclosed area, even if the windows and doors are open.

DANGER TOXIQUE. Faire fonctionner un moteur dégage de l'oxyde de carbone, un gaz inodore toxique qui peut provoquer la nausée, évanouissement ou la mort. Ne démarrer pas le moteur à l'intérieur ou dans une espace clos, meme si les fenêtres et les portes sont ouvertes.

⚠ WARNING!

- To avoid breathing in poisonous carbon monoxide from the exhaust gases, adequate ventilation should be provided if the generator set is running in a partially enclosed space.
- If the generator set is stored outdoors, check all the electrical components on the control panel before each use. Moisture can damage the generator and can lead to an electric shock.
- Do not connect an extension to the exhaust pipe.
- Generators vibrate in normal use. During and after the use of the generator, inspect the generator as well as extension cords and power supply cords connected to it for damage resulting from vibration. Have damaged items repaired or replaced as necessary. Do not use plugs or cords that show signs of damage such as broken or cracked insulation or damaged blades.
- If you start to feel sick, dizzy, or weak after the generator has been running, move to fresh air **RIGHT AWAY**. See a doctor. You could have carbon monoxide poisoning.

2. LEARN ABOUT YOUR GENERATOR

This section will show you how to identify key parts of your generator. Going over the terminology below will make sure we're on the same page.

2.1 COMPONENT IDENTIFICATION

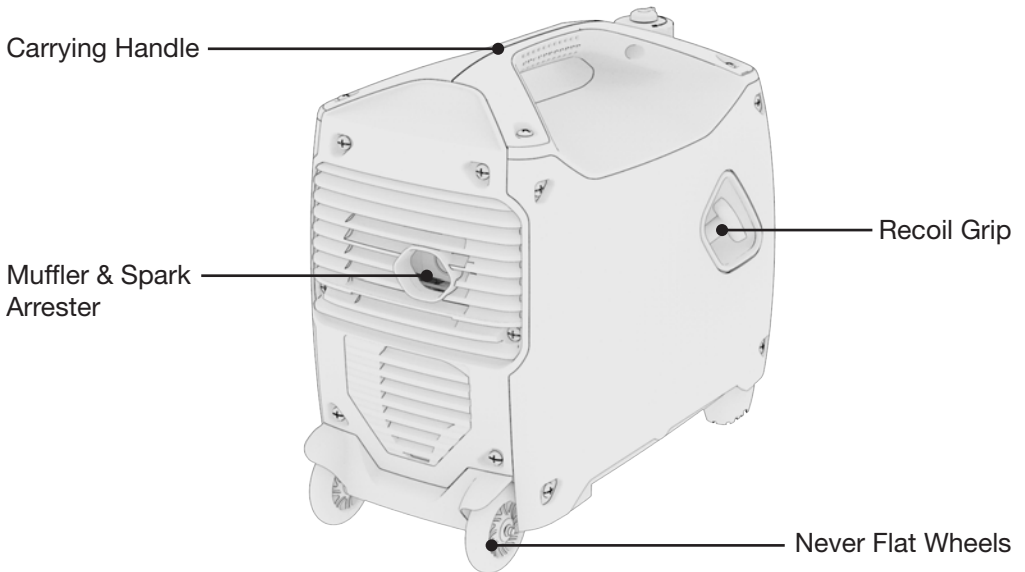
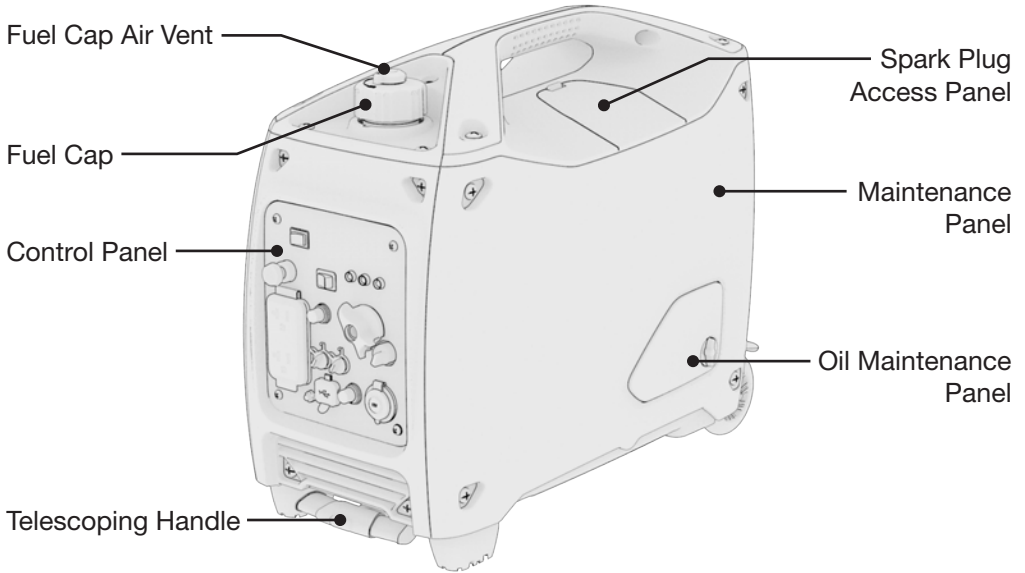

2.2 CONTROL PANEL

BG2300Di

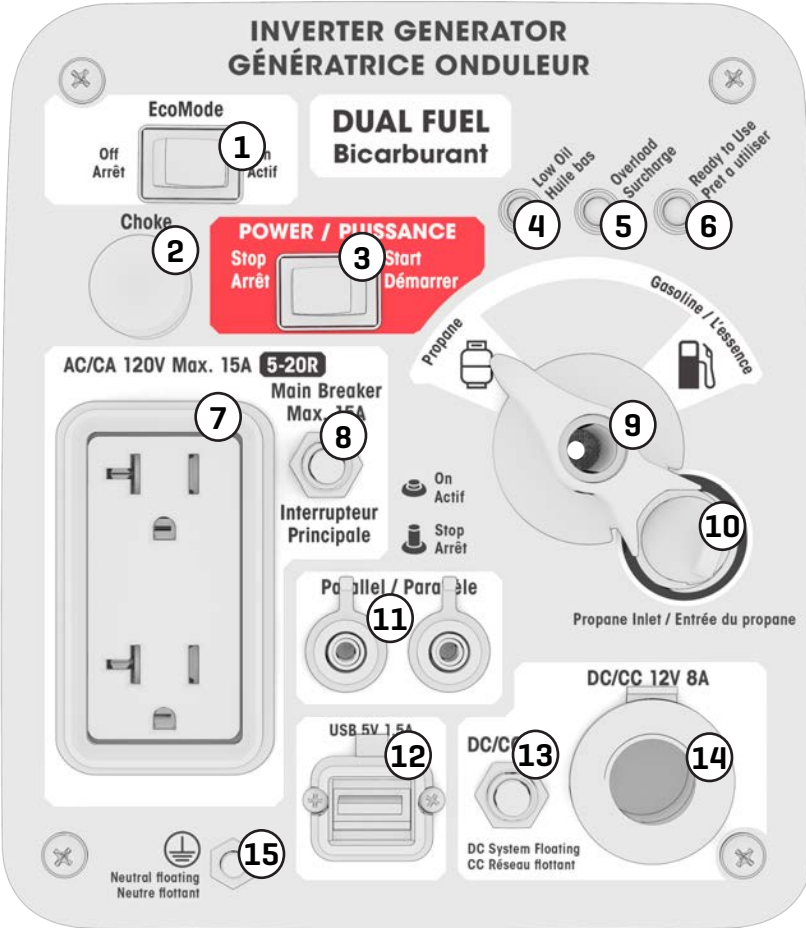

- | | |
|---------------------------|-------------------------|
| 1. EcoMode | 9. Fuel Selector Switch |
| 2. Choke | 10. Propane Inlet |
| 3. Power Switch | 11. Parallel Ports |
| 4. Low Oil Indicator | 12. 5V 1.5A USB Port |
| 5. Overload Indicator | 13. 8A DC Breaker |
| 6. Ready to Use Indicator | 14. 12V 8A DC |
| 7. 120V Max.15A (5-20R) | 15. Ground Terminal |
| 8. Main Breaker | |

2.3 CONTROL FUNCTIONS

AC Circuit Breakers

- While the generator is running, the breakers should be put in the ON position.
- If the current has exceeded its limits it will automatically pop out to the OFF position. Reduce the electrical load on the generator and push the button back to the ON position.

DC Circuit Breakers

- The DC circuit breaker automatically shuts off when the charging circuit is overloaded.
- If the current has exceeded its limits the breaker will automatically pop out to the OFF position. Reduce the electrical load on the generator and push the button back to the ON position.

EcoMode (Economy Control Switch)

- Turning EcoMode to ON is recommended for minimizing fuel consumption. In this mode the engine will dynamically meet the demand of the current electrical load and will automatically go into an idle state if all electrical loads are disconnected.
- Before connecting or removing a high load device to the generator, turn EcoMode to OFF until that device has reached running power.
- When EcoMode is OFF, the engine runs at full speed.

Fuel Selector Switch

- Switches between gasoline or propane (LPG) fuel sources.

Ground Terminal

WARNING!

Before using the ground terminal consult a qualified electrician, electrical inspector, or local agency having jurisdiction for local laws and codes that apply to the intended use of the generator.

- The ground terminal is connected to the non-current carrying metal parts (such as the fuel tank), the frame, and the ground terminals of the AC outlets. Floating Neutral.

AC Parallel Ports

- These ports allow two approved i-Series inverter generators to be connected for additional power. The parallel kit is an optional accessory.

To purchase, contact your local Home Hardware store or visit us online.

Low Oil Indicator Light

- The oil alert system is designed to prevent engine damage caused by an insufficient amount of oil in the crankcase. Before the oil level in the crankcase reaches an unsafe limit, the oil alert system will automatically shut down the engine (the battery power switch remains in the ON position).
- If the oil alert system shuts down the engine, the low oil indicator light (red) will turn on. Check the engine oil level.

Output and Overload Indicator

- In normal operation, the green output indicator light (READY TO USE) will remain on.
- If the generator is overloaded (producing more than running wattage) or a connected appliance has short-circuited, the output indicator light will turn off and the overload indicator light will turn on.

2.4 MAKE SURE YOU HAVE EVERYTHING

Make sure your generator has everything listed in the table below.

Part Name	Quantity
Inverter Generator	1
User Guide	1
Oil Bottle (350mL)	1
Oil Funnel	1
Spark Plug Wrench	1
LPG hose with regulator	1

3. PRE-OPERATION CHECK

Set the generator on a level surface and turn the fuel valve to OFF.

3.1 ADD OIL

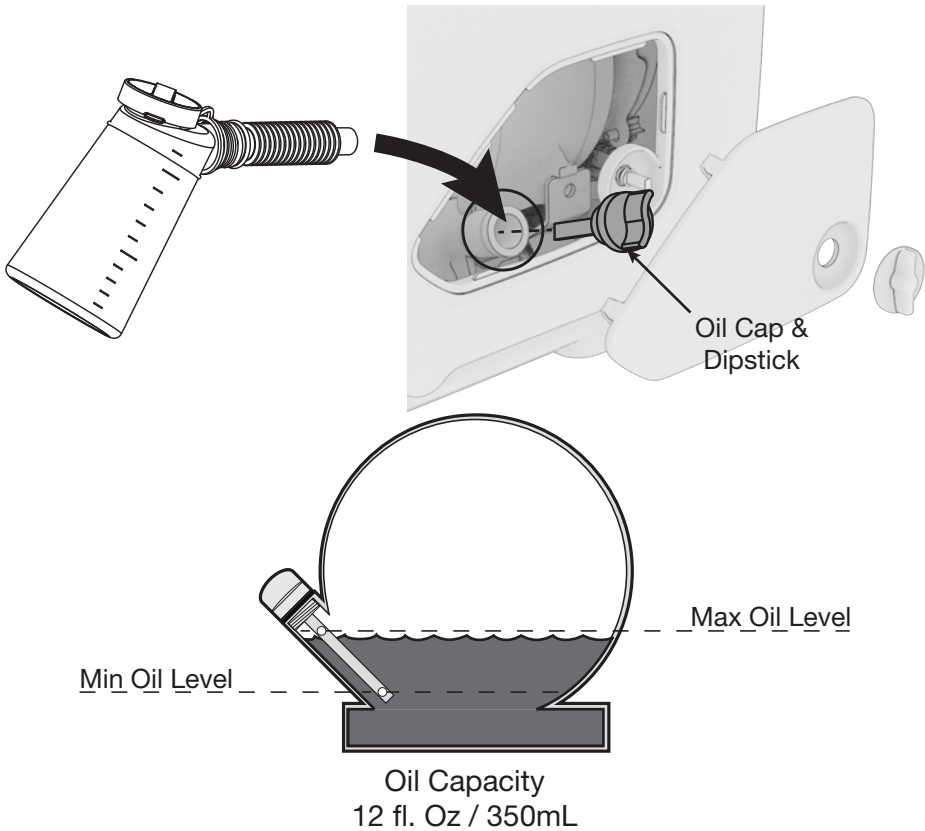

1. Remove screws, then remove the maintenance side cover.
2. Remove the crankcase dipstick.
3. Carefully add 4-Cycle engine oil (SAE 15W-40) to empty reservoir until oil reaches the outer edge of the oil fill hole (Crankcase Dipstick hole).
4. Use a clean rag to wipe up any spilled oil.
5. Replace crankcase dipstick.
6. Reinstall outer casing side cover and tighten screws.

NOTE

- Oil Capacity: 12 fl. oz / 350mL
- SAE 10W-30 or SAE 15W-40 is recommended for general use.
- Use of synthetic oil does not change maintenance intervals.
- DO NOT OVERFILL.

Effective Viscosity Range of Engine Oils



- Do not tilt the generator when adding engine oil. This could result in overfilling and damage to the engine.
- Use high quality 4-stroke engine oil, certified to meet or exceed API standard SG, SF, SAE ratings with strong detergents. Using non-detergent or 2-stroke oil could shorten the engine's working life.
- Do not mix different engine oils.
- Handle and store the engine oil with care, avoid getting dirt or dust into the engine oil.
- Before the engine oil falls below the safety margin, the low oil alert system will automatically shut off the engine. The low oil light will turn on.
- To avoid the inconvenience of unexpected engine shutoff, check the oil level as often as possible.

3.2 CHECK THE AIR FILTER

Examine the air filter before your first use. Check the maintenance section for a complete cleaning guide.

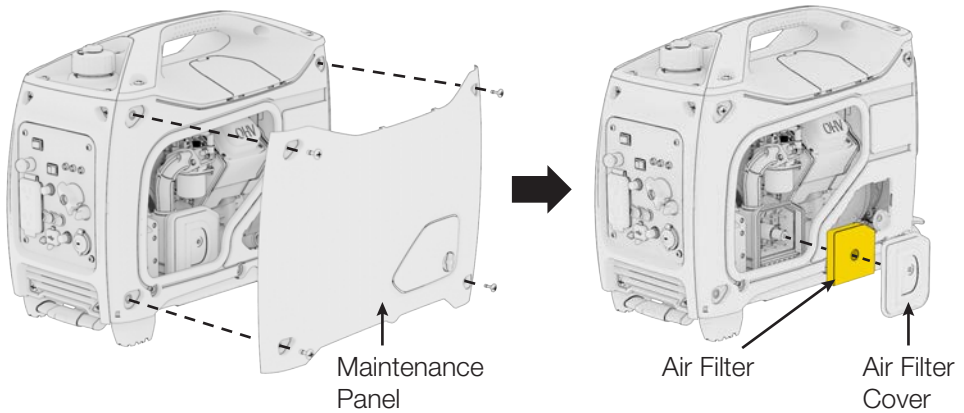

1. Remove the screws then remove the air filter cover
2. Wash the *foam* element in soapy water and let dry.
3. Pour a small amount of oil on the *foam* element then squeeze out, but do not wring out, excess oil. *Foam* element should be damp, but not dripping.
4. Reinsert the *foam* element into the sir filter case.

NOTE

- Running the engine without the air filter or a dirty air filter will quickly degrade the engine.

3.3 ADD FUEL (GASOLINE ONLY)

⚠ DANGER! ⚠

Gasoline is highly flammable and explosive under certain conditions. Refuel in a well-ventilated area with the engine stopped. Do not smoke or allow open flames or sparks in the area where the generator is being refueled or where gasoline is stored. Do not overfill the tank. Be careful not to spill fuel when refueling. Wipe up any spilled gasoline and let the area dry before starting the engine.

Gasoline substitutes such as gasohol are not recommended. They may be harmful to the fuel system components.

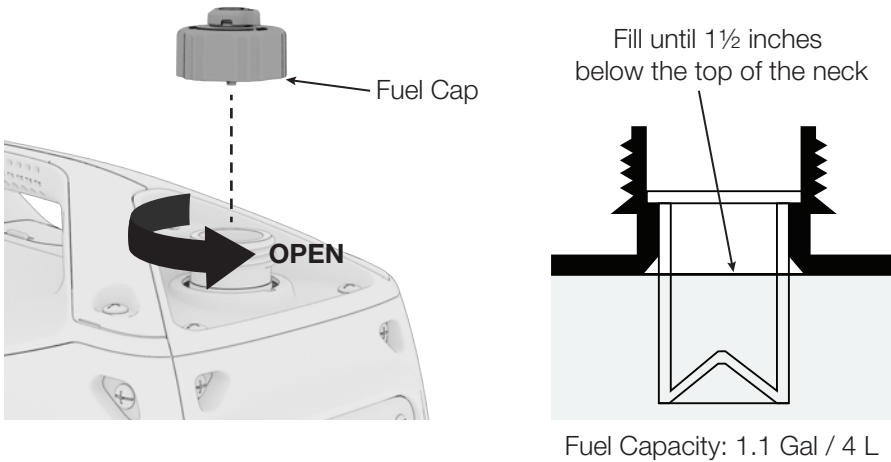

NOTE

- Use of gasoline with an ethanol content greater than 10% can damage the engine and the fuel system and will void the manufacturer's warranty.
- Only use unleaded gasoline (Octane 85 or higher).
- Never use stale or contaminated gasoline, or an oil/gasoline mixture.
- Avoid getting dirt or water into the fuel tank.
- Do not use a mixture of gasoline containing methanol. This will cause serious damage to the engine.

3.4 CHECK THE LP GAS CYLINDER CONNECTION (PROPANE ONLY)

⚠ DANGER! ⚠

Fire and explosion hazard. Never connect or disconnect the Liquid Petroleum Gas (LPG)/propane hose while the engine is running. Do not smoke or create sparks while handling LPG/propane. Always turn the engine off and allow the generator to cool for at least five minutes before connecting the propane cylinder.

⚠ WARNING!

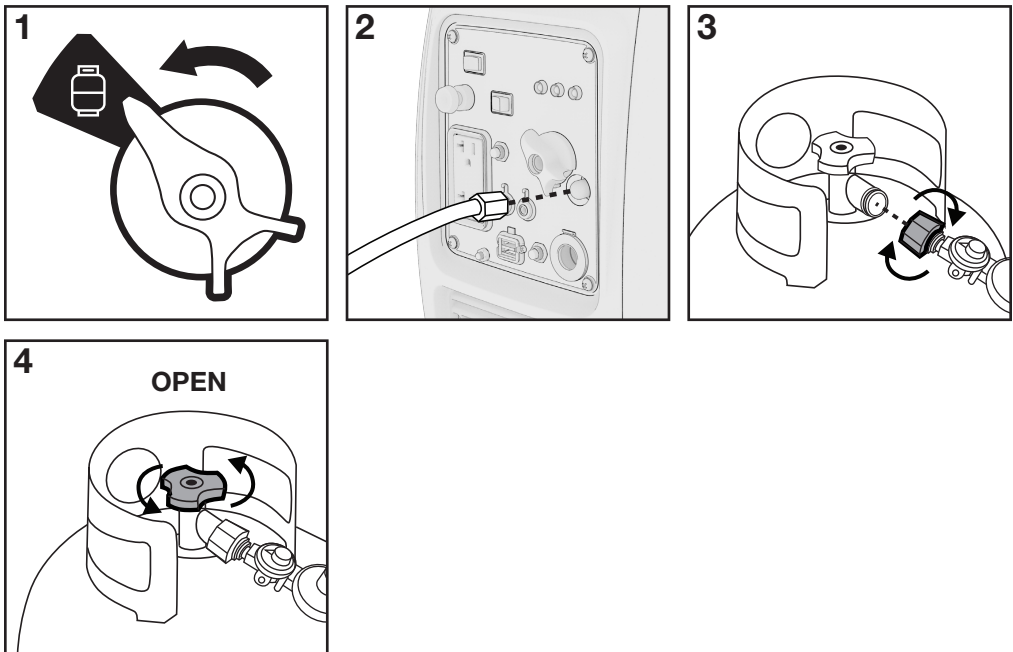

Never use a gas container, LPG/propane hose, propane cylinder or any other fuel item that appears to be damaged.

To reduce the risk of injury, perform a leak test any time the LP gas cylinder is disconnected and reconnected. Do not connect or disconnect the LP gas cylinder indoors. Do not place the LP gas cylinder in the path of the muffler exhaust.



1. Turn the fuel selector fully left to PROPANE.
2. Screw the LPG hose (included) to the panel propane connection.
3. Ensure the handwheel on the LPG hose is in the OFF position. Connect the other end of the hose to the propane cylinder.
4. Open the valve on the propane cylinder.

4. STARTING THE ENGINE

⚠ DANGER	
Using an engine indoors CAN KILL YOU IN MINUTES . Engine exhaust contains carbon monoxide. This is a poison you cannot see or smell.	
 	
NEVER use inside a home or garage, EVEN IF doors and windows are open.	Only use OUTSIDE and far away from windows, doors, and vents.
Avoid other engine hazards. READ MANUAL BEFORE USE.	

⚠ DANGER! ⚠

Using a generator indoors WILL KILL YOU IN MINUTES.

Generator exhaust contains high levels of carbon monoxide (CO), a poisonous gas you cannot see or smell. If you can smell the generator exhaust you are breathing CO. Even if you cannot smell the exhaust, you could be breathing CO.

NEVER use a generator inside a home, garage, crawlspace, or other partly enclosed area, deadly levels of carbon monoxide can build up in these areas. Using a fan or opening windows and doors will **NOT** supply enough fresh air.

ONLY use a generator outdoors and far away from open windows, doors, and vents. These openings can pull in generator exhaust. Even when you use a generator correctly, CO may leak into the home. **ALWAYS** use a CO alarm in your home.

If you start to feel sick, dizzy, or weak after the generator has been running, move to fresh air **RIGHT AWAY** and seek medical attention. You could have carbon monoxide poisoning. Never run the generator in an enclosed or even partially enclosed area where people may be present.

4.1 STARTING YOUR DUAL FUEL GENERATOR

DANGER!

Liquid Petroleum Gas (LPG) is highly flammable. Do not store or use LPG in an enclosed area. Do not expose the LPG cylinder to excessive heat. Fully close the LPG cylinder when the generator is not in use or is running with gasoline. Never use a gas container, LPG connector hose, LPG cylinder or any other fuel item that appears damaged.

If you smell gas, close the gas supply and check all connections for leaks before attempting to use the generator again.

WARNING!

Before using the generator, a ground wire may need to be connected to the ground terminal. The terminal is located on the front panel. Before using the ground terminal consult a qualified electrician.

NOTE

- Check the LPG connections for leaks by wetting the hose fittings with soapy water. If bubbles appear or grow in these fittings, there is a leak. Turn off all valves and tighten the connections. Turn valves back on and recheck with soapy water. Do not use the generator and contact customer service if the leak continues or if it is not possible to identify the source of the leak.
- Do not push the choke lever to the START/CLOSED position when the engine is hot or ambient air temperature is high.
- If recoil starting, return the starter grip slowly by hand, do not let it snap back.

4.2 GASOLINE MANUAL RECOIL START

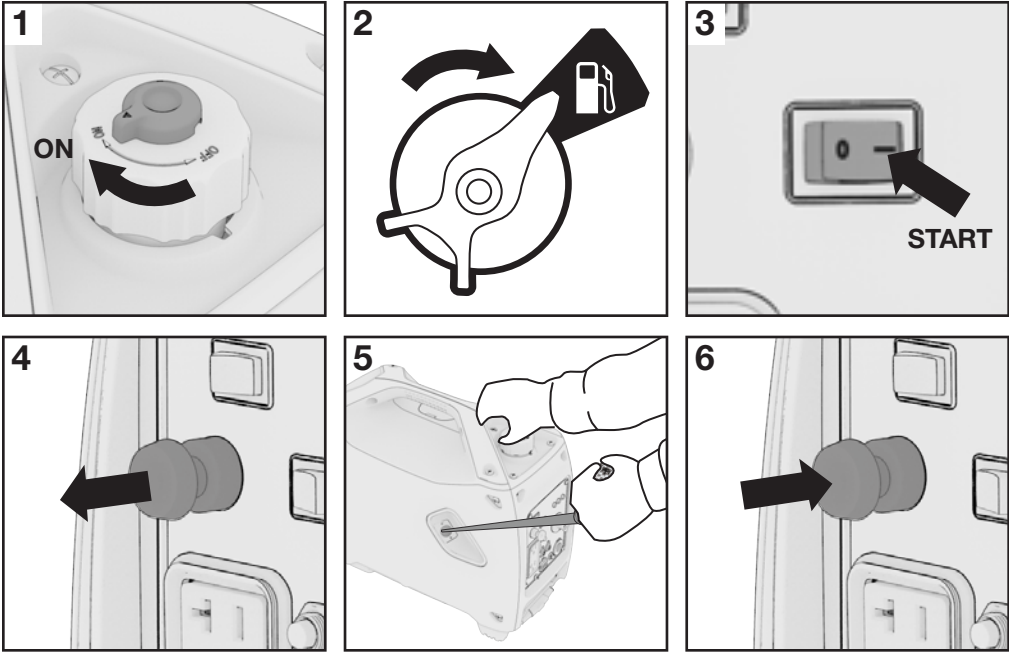

1. Turn the fuel cap air vent to the ON position.
2. Turn the fuel selector on the panel to GASOLINE.
3. Turn the power switch to the START position.
4. Pull the choke lever out.
5. Pull the starter slowly until it engages then pull quickly. Repeat until the generator starts.
6. Let engine run for several seconds and then gradually as engine warms up, push in the choke lever.

4.3 PROPANE (LPG) MANUAL RECOIL START

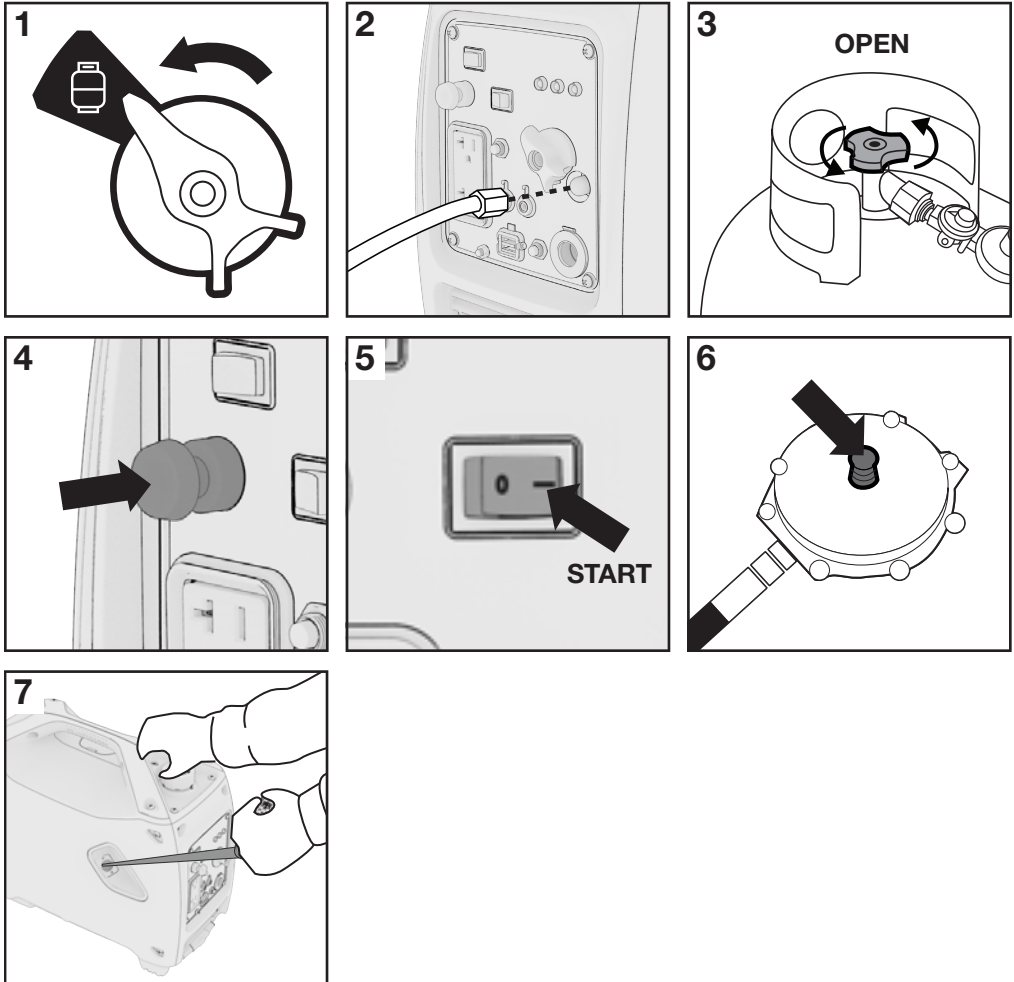

1. Turn the fuel selector fully left to PROPANE.
2. Screw the LPG hose to the panel propane connection.
3. Turn on the propane supply.
4. Press the choke lever in.
5. Turn the engine switch to START.
6. Press the decompression valve button for 3 to 5 second
7. Pull the starter slowly until it engages then pull quickly. Repeat 3-4 times until the generator starts.
8. Repeat step 6 and 7 until the generator is started.

5. GENERATOR USE

⚠ WARNING!

Do not connect directly to the building’s electrical system. Doing so may result in electrical shocks, fire, and backfeeding the grid. Connections for standby power to a building’s electrical system *must* be done by a qualified electrician and must comply with all applicable laws and electrical codes. See Chapter 1.2 - Safety for more information.

Before using the generator, consult a local electrician and local electrical codes to determine grounding requirements for your intended use. This generator is floating neutral.

Use only grounded 3-prong extension cords in good condition, ensure the wire size is sufficient to safely carry the generator’s wattage. See Chapter 1.2 - Safety for more information.

5.1 OUTPUT, OVERLOAD, AND OIL ALERT INDICATOR

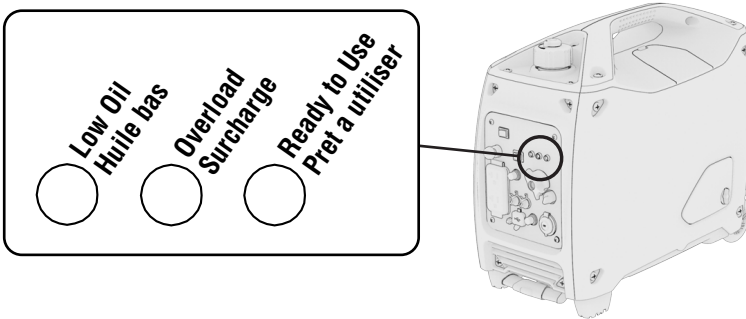

Light (Solid)			Description
Green	Output Indicator	ON	Indicates normal operation
		OFF	Indicates a problem or unit is off
Red	Overload Indicator	ON	Indicates overload or problem with connected appliances, disconnect any appliances.
		OFF	Indicates normal operation
Red	Low Oil Indicator	ON	Indicates insufficient oil in the crankcase
		OFF	Indicates normal operation

5.2 DC APPLICATIONS

The DC receptacle may be used for charging 12V batteries only. In DC operation, turn EcoMode OFF.

NOTE

- The DC receptacle can be used while the AC power is in use. If used at the same time, be sure not to exceed the total power for AC and DC. (AC: Rated Running Watts, DC: 8A)
- The BG4500i can not jump start vehicles.

Connecting the charging cable:

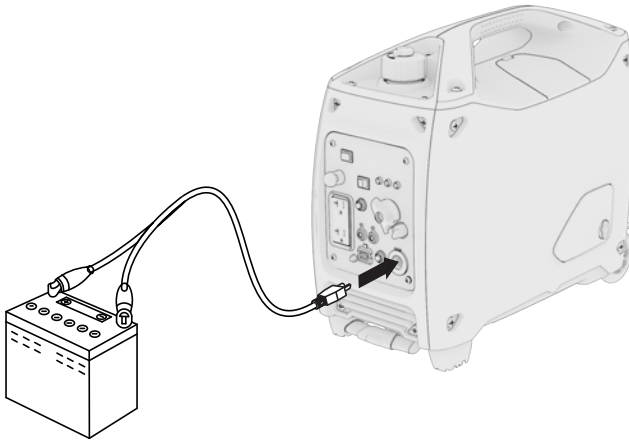

1. If connecting to a vehicle battery, disconnect the vehicle battery ground cable from the negative (-) battery terminals.
2. Connect the DC outlet to the battery terminals using a DC charging cable (not included). Connect red lead to positive (+) battery terminal and black lead to negative (-) battery terminal.
3. Turn EcoMode OFF, and start the generator.

NOTE

- Do not start the vehicle engine when the generator is still connected to the battery, this will damage the generator.
- System floating for DC output.

Disconnecting the charging cable:

1. Stop the engine.
2. Disconnect the black lead from the negative (-) battery terminal, and the red lead from the positive (+) battery terminal.
3. Reconnect the vehicle battery ground cable.

5.3 AC APPLICATIONS

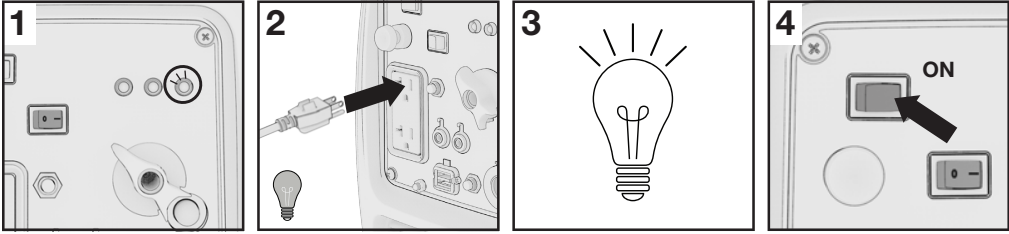

1. Start engine and make sure output indicator light (READY TO USE) is on.
2. Confirm all electrical appliances are switched off, and connect the appliance plugs to the generator receptacle.
3. Turn on the appliances.
4. Turn EcoMode ON.

NOTE

- Confirm all electrical appliances are in good working condition before connecting them to the generator. If an electrical appliance becomes abnormal, sluggish, or stops suddenly, shut off the generator engine immediately, and disconnect the appliance.
- Most appliances require more than their rated wattage upon startup.
- For continuous operation do not exceed the rated output of the generator.
- The grounding system is not connected to the AC neutral wire.
- Neutral floating for AC system.

5.4 AC PARALLEL OPERATION

⚠ WARNING!

Do not start the generators before connecting the parallel cable. If the cable is connected while one generator is running it will be overloaded.

NOTE

- For continuous operation do not exceed the combined rated power.
- Stop the engine before connecting or removing the parallel cable.
- For single unit operation the parallel cable must be removed.
- The onboard generator outlets will not function when the parallel kit is plugged in.

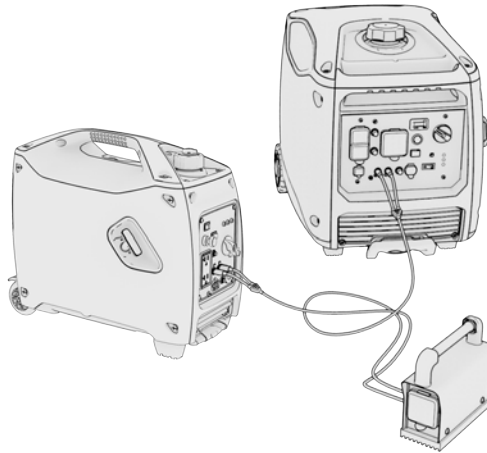

1. Make sure both generators are OFF.
2. Connect the two parallel connectors to the two parallel sockets of each generator.
3. Connect the ground wires to the ground terminal of each generator.
4. Start each engine according to 'Starting the Engine' chapter.
5. Confirm appliances are turned off, then connect the appliance to the parallel kit.
6. Turn on the appliance.

5.5 EXTENDING THE HANDLE

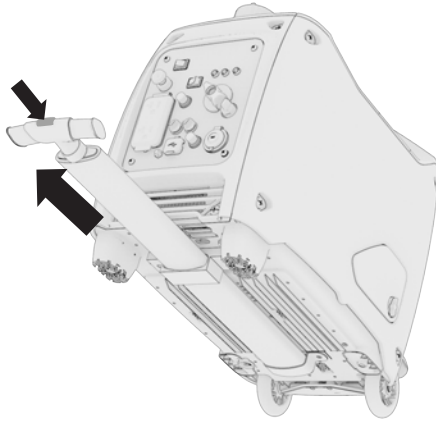

1. Depress the handle lock and pull outwards to extend the telescoping handle.

6. STOPPING THE ENGINE

Normal Operation (Gasoline)

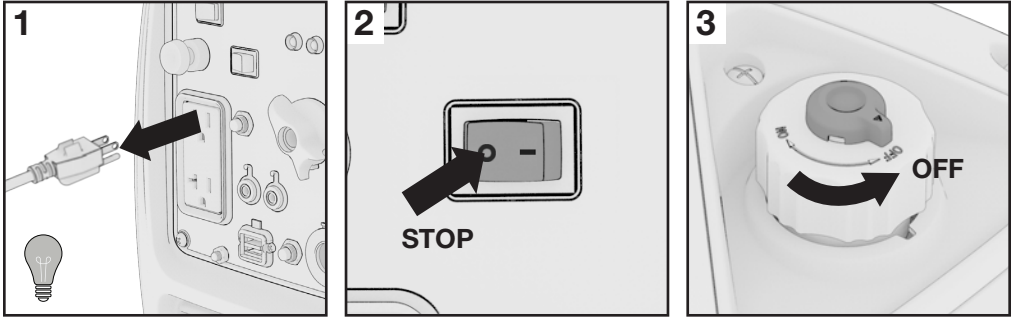

1. Switch off the connected electrical appliances, and disconnect them from the generator.
2. Turn the power switch to the STOP position.
3. Turn the fuel cap air vent to the OFF position.

Normal Operation (Propane if equipped)

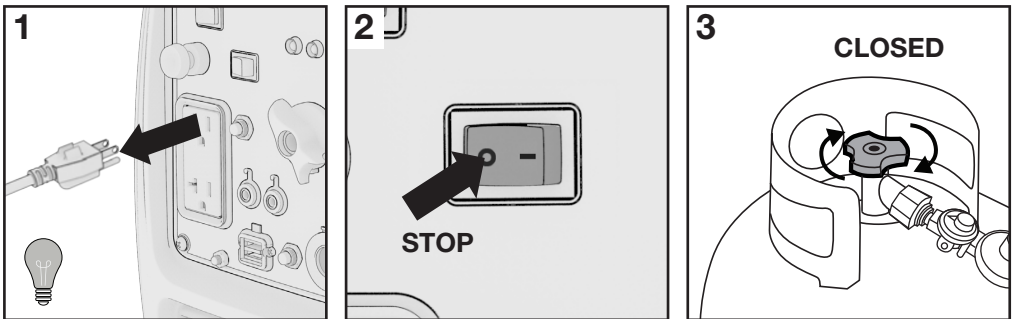

1. Switch off the connected electrical appliances, and disconnect them from the generator.
2. Turn the power switch to the STOP position.
3. Close the supply valve on the propane cylinder.

7. MAINTENANCE

Proper maintenance keeps your generator in the best operating condition by ensuring safe, economical and trouble-free operation. Only use genuine parts and recommended fluids to replace the worn components. Improper maintenance may cause the generator to malfunction and can lead to serious injury. Contact customer support if you have any maintenance questions.

General Inspection Tips

- Look for fuel leaks around the fuel tank, fuel hose, and fuel valve. Close the fuel valve and repair leaks immediately.
- Look and listen for exhaust leaks while the engine is running. Have all the leaks repaired before continuing operation.
- Check for dirt and debris and clean as necessary .
- Check the engine oil level and add oil as necessary.

7.1 MAINTENANCE SCHEDULE

Regular maintenance will improve performance and extend the service life of the generator. Maintain the generator according to the maintenance schedule below.

NOTE

- Service more frequently when used in dusty areas.
- These items should be serviced by an authorized service center, unless you have the proper tools and are mechanically proficient. Refer to manual for service procedures.

Before Each Use
Check engine oil level Inspect air filter
First 5 Hours or First Month
Change engine oil
Every 100 Hours or 6 Months
Change engine oil ² Check and clean air filter ¹ Check and clean sediment cup Inspect/clean spark arrestor Inspect/clean spark plug Check Muffler Screen
Every 300 Hours or 12 Months
Inspect/clean fuel filter Check crankcase breather hose for cracks or damage De-carbonize cylinder head ³ Inspect/adjust valve clearance ³ Check all fittings and fasteners ³

¹ Replace air filter if it cannot be adequately cleaned.

² Change oil after every 100 hours or yearly, whichever comes first. Service more frequently when operating under heavy load or in high temperatures.

³ Recommend service to be performed by authorized service dealer.

7.2 CHANGING THE OIL

⚠ WARNING!

Used motor oil can cause skin irritations if left in long-term contact with skin. Thoroughly wash off used oil as soon as possible with soap and water.

Do not dispose of used oil in drains or on soil. Local service shops provide environmentally-friendly disposal methods.

Drain the oil rapidly and completely while the engine is still warm.

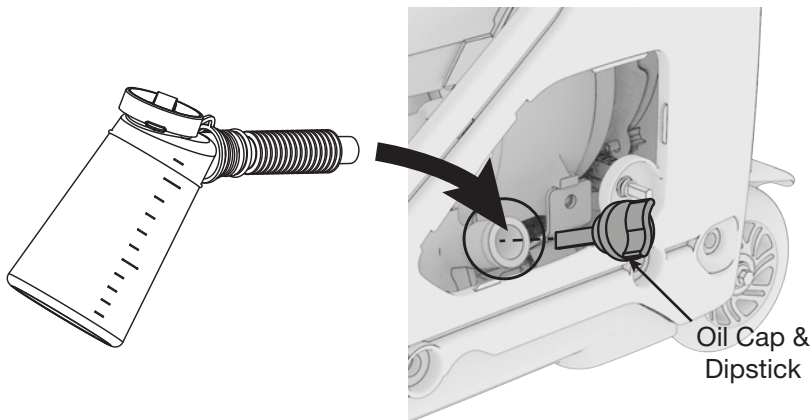
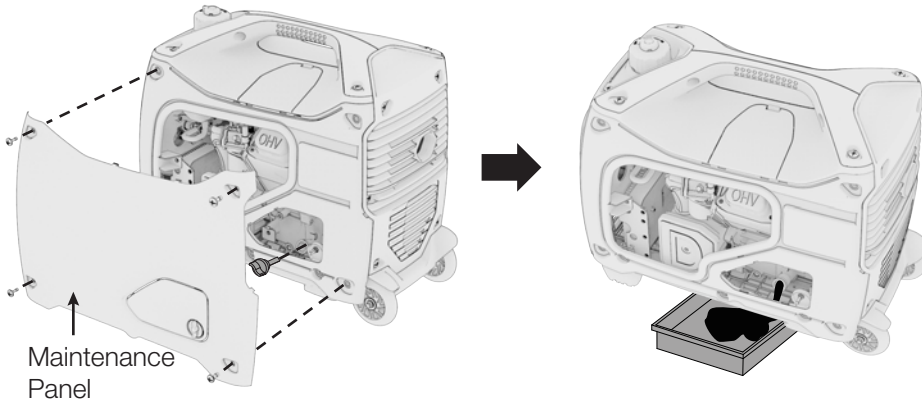

1. Place generator on a level surface.
2. Run the generator for several minutes until the engine is warm. Turn off generator.
3. Remove screws, then remove the maintenance side cover.
4. Remove the crankcase dipstick.
5. Place an oil pan underneath the engine. Tilt generator to collect used oil. Allow oil to drain completely.

6. Return generator to a level surface.
7. Carefully add 4-Cycle engine oil (SAE 15W-40) to empty reservoir until oil reaches the outer edge of the oil fill hole (Crankcase Dipstick hole).
8. Use a clean rag to wipe up any spilled oil.
9. Replace crankcase dipstick.
10. Reinstall outer casing side cover and tighten screws.

NOTE

- Max oil capacity: 12 fl. oz / 350mL
- SAE 10W-30 or SAE 15W-40 oil is recommended for general use.
- Use of synthetic oil does not change maintenance intervals.
- DO NOT OVERFILL.

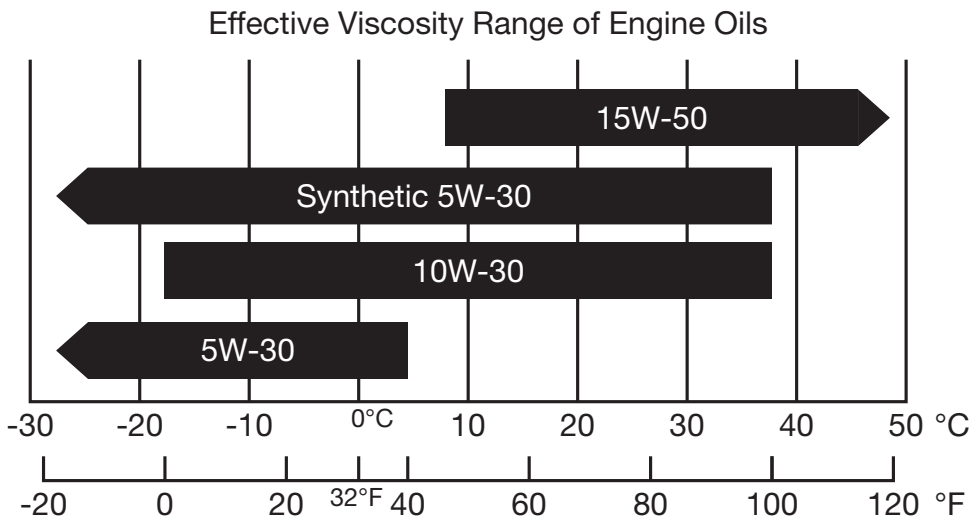

NOTE

- Do not tilt the generator when adding engine oil. This could result in overfilling and damage to the engine.
- Use high quality 4-stroke engine oil, certified to meet or exceed API standard SG, SF, SAE ratings with strong detergents. Using non-detergent or 2-stroke oil could shorten the engine's working life.
- Do not mix different engine oils.
- Handle and store the engine oil with care, avoid getting dirt or dust into the engine oil.
- Before the engine oil falls below the safety margin, the low oil alert system will automatically shut off the engine. The low oil light will turn on.

- To avoid the inconvenience of unexpected engine shutoff, check the engine oil level as often as possible.

7.3 CLEANING THE AIR FILTER

⚠ WARNING!

Using gasoline or other flammable solvents can cause a fire or explosion. Do not operate this product without an air filter.

A dirty air filter will restrict air flow into the carburetor. Clean and maintain the air filter regularly, especially in dusty areas.

NOTE

- Never run the generator without an air filter, doing so will quickly degrade the engine.

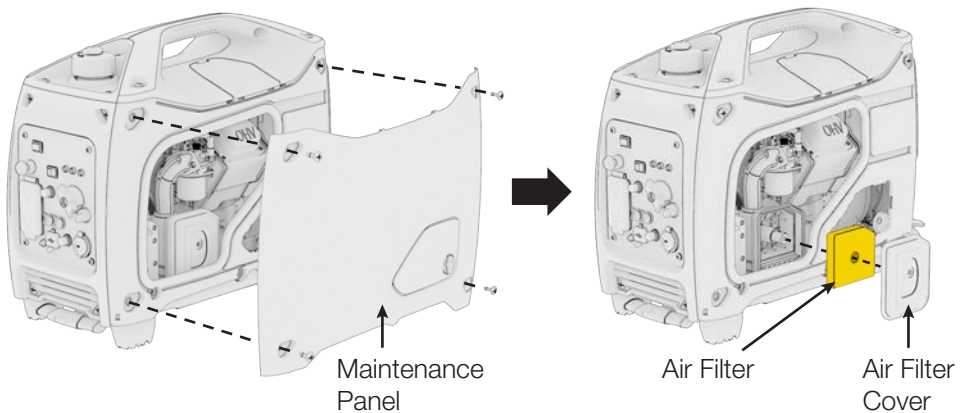

1. Remove the screws then remove the air filter cover
2. Wash the *foam* element in soapy water and let dry.
3. Pour a small amount of oil on the *foam* element then squeeze out, but do not wring out, excess oil. *Foam* element should be damp, but not dripping.
4. Reinsert the *foam* element into the sir filter case.

7.4 SPARK PLUG SERVICE

NOTE

- Do NOT rinse spark plug in water. Follow guidelines and be careful not to overtighten the spark plug.

Recommended spark plug: **E6RTC**

Check the spark plug gap and clean the carbon deposits at the bottom of the spark plug.

Tighten 1/2 turn when installing a new spark plug.

Tighten 1/8 TO 1/4 turn when re-installing an old spark plug.

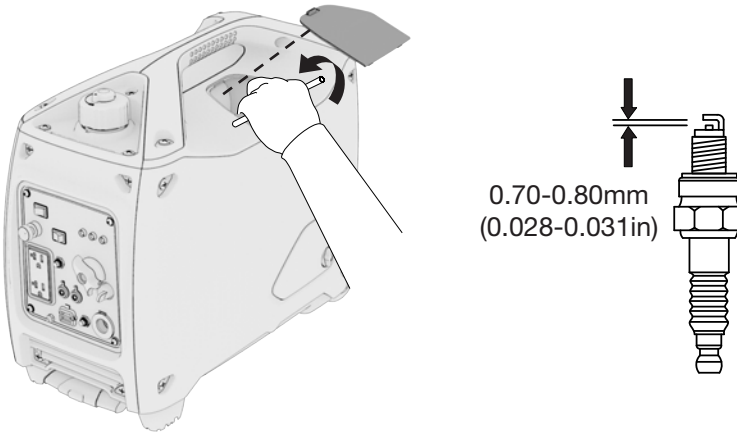

1. Remove the air filter access panel.
2. Remove the spark plug cap.
3. Remove the spark plug with the spark plug wrench.
4. Visually inspect the spark plug. Replace with a new one if the insulation is cracked or chipped. Clean with a wire brush if the spark plug is reused.
5. Measure the spark plug gap with a feeler gauge. The normal value is: 0.7-0.8mm (0.028- 0.031in). Adjust the gap by carefully bending the electrode.
6. Carefully reinstall the spark plug by hand, to avoid cross-threading. A new spark plug should be tightened 1/2 turn with a wrench. A used spark plug should be tightened 1/8 to 1/4 turn with wrench.
7. Reinstall the spark plug cap.
8. Reinstall the spark plug maintenance cover.

NOTE

- The spark plug must be securely tightened or it could cause the spark plug to heat up enough to damage the engine.
- Never use a spark plug with an improper heat range.

7.5 SPARK ARRESTER MAINTENANCE

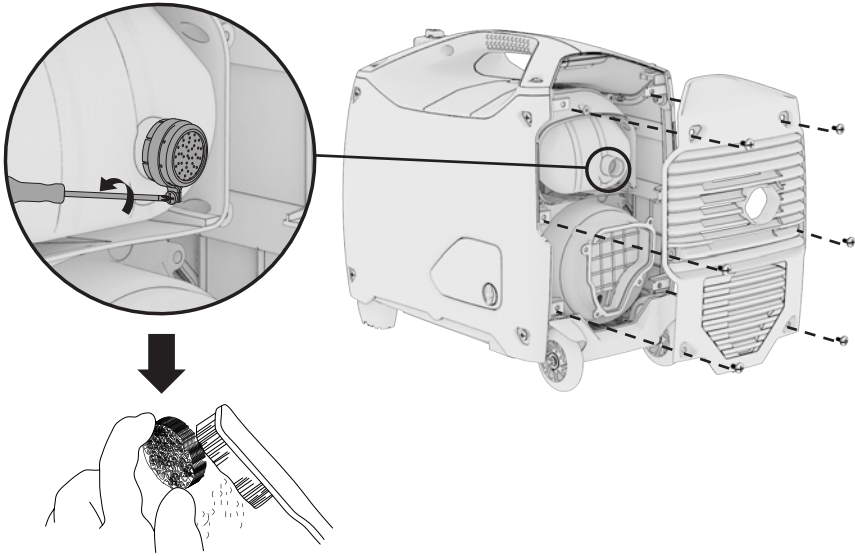

1. Inspect the muffler for cracks, corrosion, or other damage
2. Remove screws, then remove the muffler cover as shown.
3. Loosen bolt, then remove muffler cap, muffler screen, and spark.
4. Check the muffler screen and spark for carbon deposits. Remove carbon deposits with a wire brush.
5. Check the muffler screen and spark for damage. If damaged replace with pipe replacement parts specifically designed for this unit
6. Install the spark. Align the spark projection with the hole in the muffler pipe.
7. Install the muffler screen and muffler cap
8. Install the outer casing and tighten the screws.

7.6 FUEL FILTER MAINTENANCE

⚠ WARNING!

Gasoline is highly flammable and explosive under certain conditions. Refuel in a well-ventilated area with the engine stopped. Do not smoke or allow open flames or sparks in the area where the generator is being refueled or where gasoline is stored. Do not overfill the tank. Be careful not to spill fuel when refueling. Wipe up any spilled gasoline and let the area dry before starting the engine.

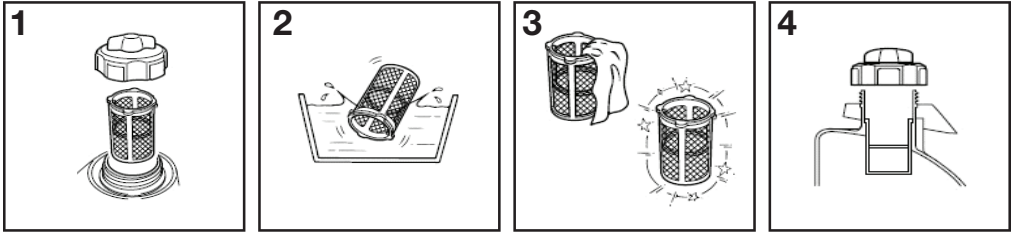

1. Remove the fuel cap and filter.
2. Clean the filter with solvent.
3. Wipe the filter.
4. Reinsert the filter.

7.7 CARBURETOR MODIFICATION FOR HIGH ALTITUDE OPERATION (Above 2,000 feet)

NOTE

- This engine is equipped to run at altitudes below 2,000-ft.
- A high-altitude main jet is recommended when operated at 2,000 to 7,000-ft above sea level.
- At elevations above 7,000-ft the engine may experience decreased performance even with a high-altitude main jet.

At high altitudes the carburetor's air/fuel mixture becomes too rich, resulting in higher fuel consumption, lower performance, and carbon build-up on the spark plug. On the other hand, if the carburetor has been modified for high altitude operation and is operated below 2000-ft, the air/fuel mixture will then be too lean for low altitude use. Always use the correct main jet for your altitude.

The engine's carburetor, governor (if so equipped), and any other parts that control the air/fuel ratio will need to be adjusted by a qualified mechanic to allow efficient high-altitude use, and to prevent damage to the engine and any other devices used with this product. The fuel system on this engine may be influenced by operation at higher altitudes.

- Carburetor bowl may have gas in it which will leak upon removing the bolt.
- The mixing tube is held in place by the main jet and might fall out when it is removed. If it falls out, replace it in the same orientation before replacing the main jet.
- The fuel cup seal and bolt seal may be damaged during removal and should be replaced with the new ones.

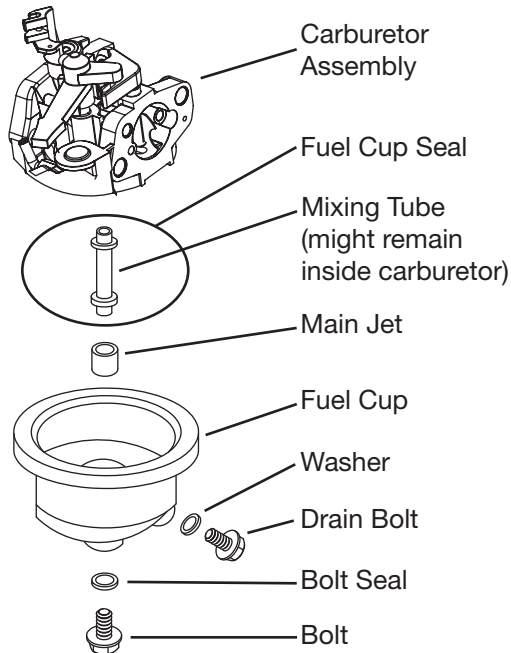

1. Turn off the engine.
2. Close the fuel valve.
3. Place a bowl under the fuel cup to catch any spilled fuel.
4. Unthread the bolt holding the fuel cup.
5. Remove the bolt, bolt seal, fuel cup, fuel cup seal and main jet from the body of the carburetor assembly. A carburetor screwdriver (not included) is needed to remove and install the main jet.
6. Replace the main jet with the replacement main jet needed for your altitude range.
7. Replace the fuel cup seal, fuel cup, bolt seal, and bolt. Tighten in place. Do not cross thread bolt when tightening. Finger tighten first and then use a wrench to make sure the bolt is properly threaded.
8. Wipe up any spilled fuel and allow excess to evaporate before starting engine. To prevent FIRE, do not start the engine while the smell of fuel hangs in the air.

7.8 EMISSION CONTROL SYSTEM

Emission Source

Exhaust gas contains carbon monoxide, nitrogen oxides (NO_x) and hydrocarbons. It is very important to control the emissions of NO_x and hydrocarbons as they are a major contributor to air pollution. Carbon monoxide is a poisonous gas. The emission of fuel vapors is a source of pollution as well. The generator engine utilizes a precise air-fuel ratio and emission control system to reduce the emissions of carbon monoxide, NO_x, hydrocarbons and evaporative fuel emissions.

Regulation

Your engine has been designed to meet current Environmental Protection Agency (EPA) and the California Air Resource Board (CARB) clean air standards. The regulations dictate that the manufacturer provides operation and maintenance standards regarding the emission control systems. Tune up specifications are provided in the Specifications section and a description of the emission control system may be found in the appendix to this manual. Adherence to the following instruction will ensure your engine meets the emission control standards.

Modification

Modification of the emission control system may lead to increased emissions. Modification is defined as the following:

- Disassembling or modifying the function or parts of the intake, fuel or exhaust system.
- Modifying or destroying the speed governing function of the generator.

Engine faults that may affect emission

Any of the following faults must be repaired immediately. Consult with your authorized service centre for diagnosis and repair:

- Hard starting or shut down after starting.
- Unstable idle speed.
- Shut down or backfire after applying an electrical load.
- Backfire or after fire.
- Black smoke and/or excessive fuel consumption.

Replacement parts and accessories

The parts making up the emission control system in your product's engine have been specifically approved and certified by the regulatory agencies. You can trust that the replacement parts supplied by customer service have been manufactured to the same production standard as the original parts. The use of replacement parts or accessories which are not designed by – may negatively affect the engine emission performance. Therefore only use replacements parts and accessories from a qualified service centre to guarantee that the replacement products will not adversely affect emission performance.

Replacement parts other than those from an authorized service centre will void the warranty.

Air Index (Models certified for sale in California)

An Air Index Information label is applied to engines certified to an emission durability time period in accordance with the requirements of the California Air Resources Board.

The bar graph is intended to provide you, our customer, the ability to compare the emissions performance of available engines. The lower the Air Index, the less pollution.

The durability description is intended to provide you with information relating to the engine's emission durability period. The descriptive term indicates the useful life period for the engine's emission control system.

The Air Index information hang tag must remain on the generator until it is sold. Remove the hang tag before operating the generator.

8. TRANSPORTATION & STORAGE

Draining the Fuel Tank

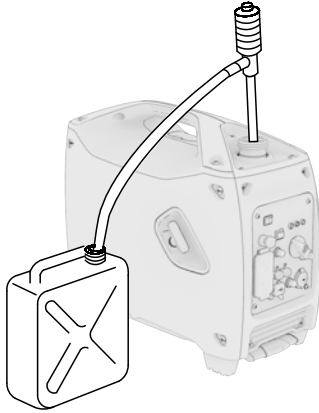

1. Turn OFF the engine. Remove the fuel cap and the debris screen underneath the fuel cap.
2. Empty the fuel tank using a siphon and an approved gasoline container.
3. Loosen the carburetor drain bolt to discharge all gasoline from inside of the carburetor.

Transporting the Generator

1. Do not overfill the fuel tank (No residual fuel on the neck of tank).
2. Do not use the generator in the vehicle. The generator should ONLY be used while in a well ventilated area.
3. Avoid exposing the generator to prolonged direct sunlight while in an enclosed vehicle. The high temperature inside the vehicle could cause fuel to vaporize resulting in a possible explosion.
4. Drain the generator of fuel and oil before being transported on rough roads.

Storage

Gasoline can oxidize in as little as 30 days, causing gum and varnish to build up in fuel system components.

NOTE

- Ensure that the storage area is free of excess humidity and dust.

Storage Duration	Preparation Required
Less than 1 Month	<ul style="list-style-type: none">■ No storage preparation required, simply store as is.
1 Month to 1 Year	<ul style="list-style-type: none">■ Drain the old gas and completely fill the tank with fresh gas before storage. Add fuel stabilizer according to the manufacturer's directions. Adding a quality fuel stabilizer can keep gas fresh for up to a year.
1 Year or More	<ul style="list-style-type: none">■ Drain off the gasoline from the fuel tank, and store in a suitable container. This will help prevent deposits from forming in the fuel system.■ Turn the fuel switch to OPEN and loosen the carburetor drain bolt. Take off the spark plug cap and revolve the engine 3 or 4 times, by pulling the recoil handle, to fully discharge the gasoline from the fuel lines.■ Turn the fuel switch to CLOSED and tighten the drain bolt of the carburetor.■ Change oil while engine is still warm from operation.■ Remove the spark plug, and pour a tablespoon of clean engine oil (10~20ml) into the cylinder. Revolve the engine several times by pulling on the recoil start to distribute the oil. Reinstall the spark plug. Pull the starter grip slowly until you feel resistance. At this point, the piston is coming up on its compression stroke and both the intake and exhaust valves are closed. This position helps to protect the engine from internal corrosion.

9. TROUBLESHOOTING

If appliances do not operate:

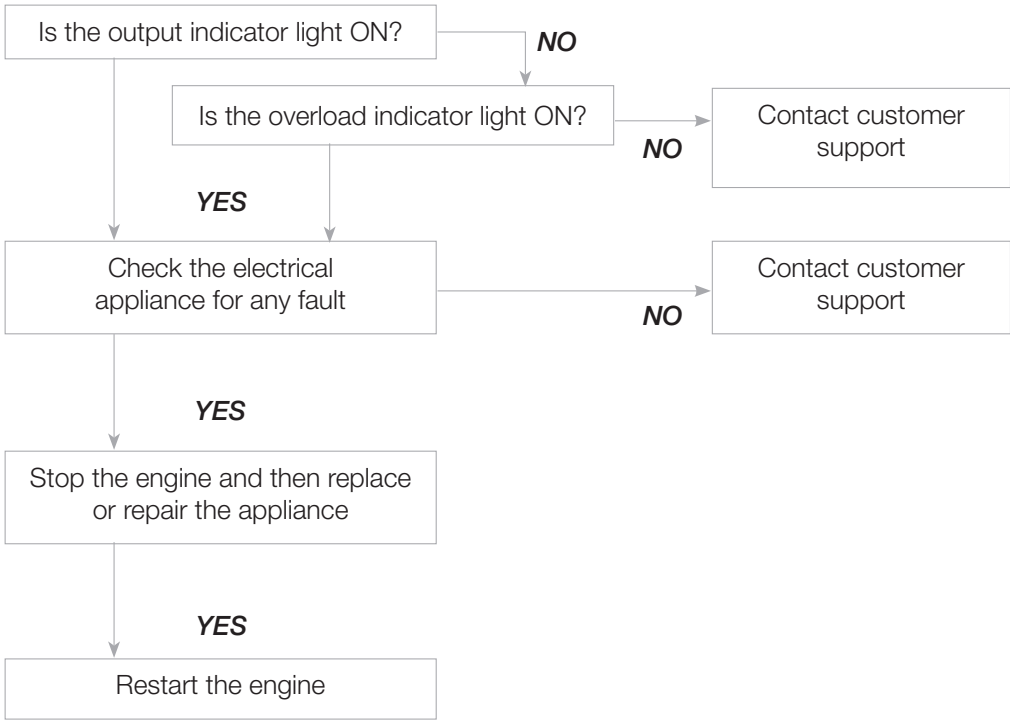

DC receptacle without any electricity:

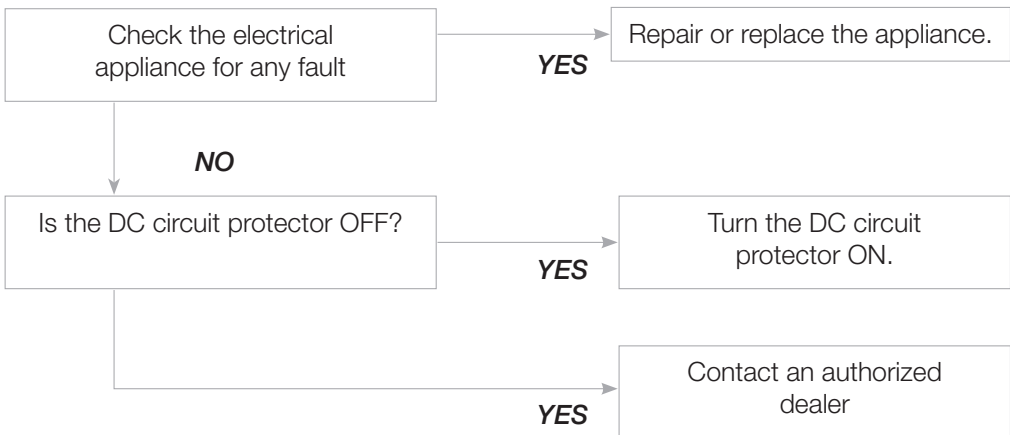

If the engine does not start:

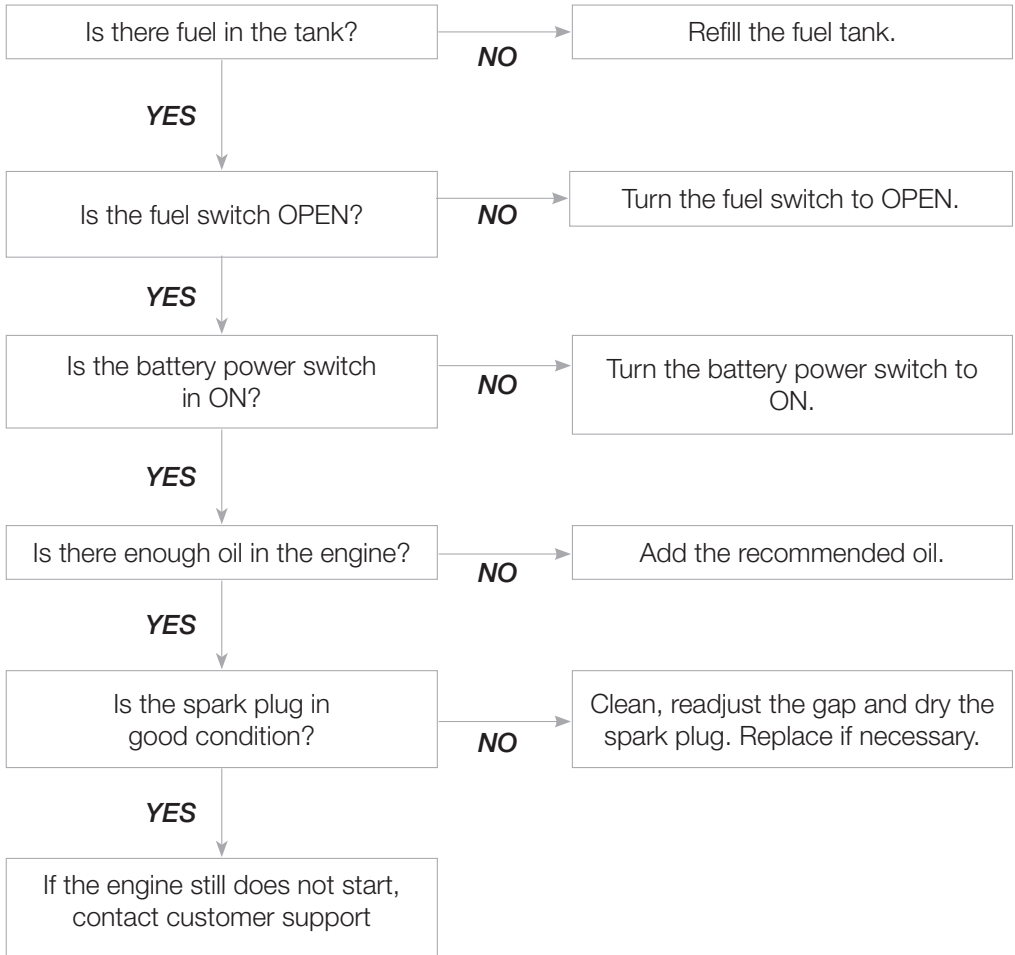

10. TECHNICAL SPECIFICATIONS

	SPECIFICATIONS	PARAMETERS
ENGINE	Type	4-stroke, overhead valve, single cylinders, forced-air cooling
	Engine Displacement	80cc
	Engine Speed	5400 rpm
	Spark Plug	E6RTC/BPR7HS
	Spark Plug Gap	0.028-0.031 in (0.7 - 0.8mm)
	Start System	Recoil Start
	Fuel Type	Unleaded Gasoline
	Oil Capacity	12 fl. oz. / 350mL
	Oil Type	SAE 10W-30 / 15W-40
GENERATOR	Model Name	BG2300Di
	Rated Frequency	60Hz
	Rated Voltage	120V
	Rated Current	15A (13.3A LPG)
	Rated Speed	2800-3600rpm
	Max Output Power	2300W (2000W LPG)
	Rated Output Power	1800W (1600W LPG)
OTHER SPECIFICATIONS	DC Output	12V/8A
	Fuel Tank Volume	1.1 Gal / 4L
	Continuous Running Time	3.2h @ 100% Load
	Noise Level	61 - 70 dBA
	Working Ambient Temperature	5°F to 104°F (-15°C to 40°C)
	Dimensions (L*W*H)	21 x 11.1 x 18.1 in
	Net Weight	50.6 lbs / 23 kg

- Noise level is measured when EcoMode is ON.

11. WIRING DIAGRAM

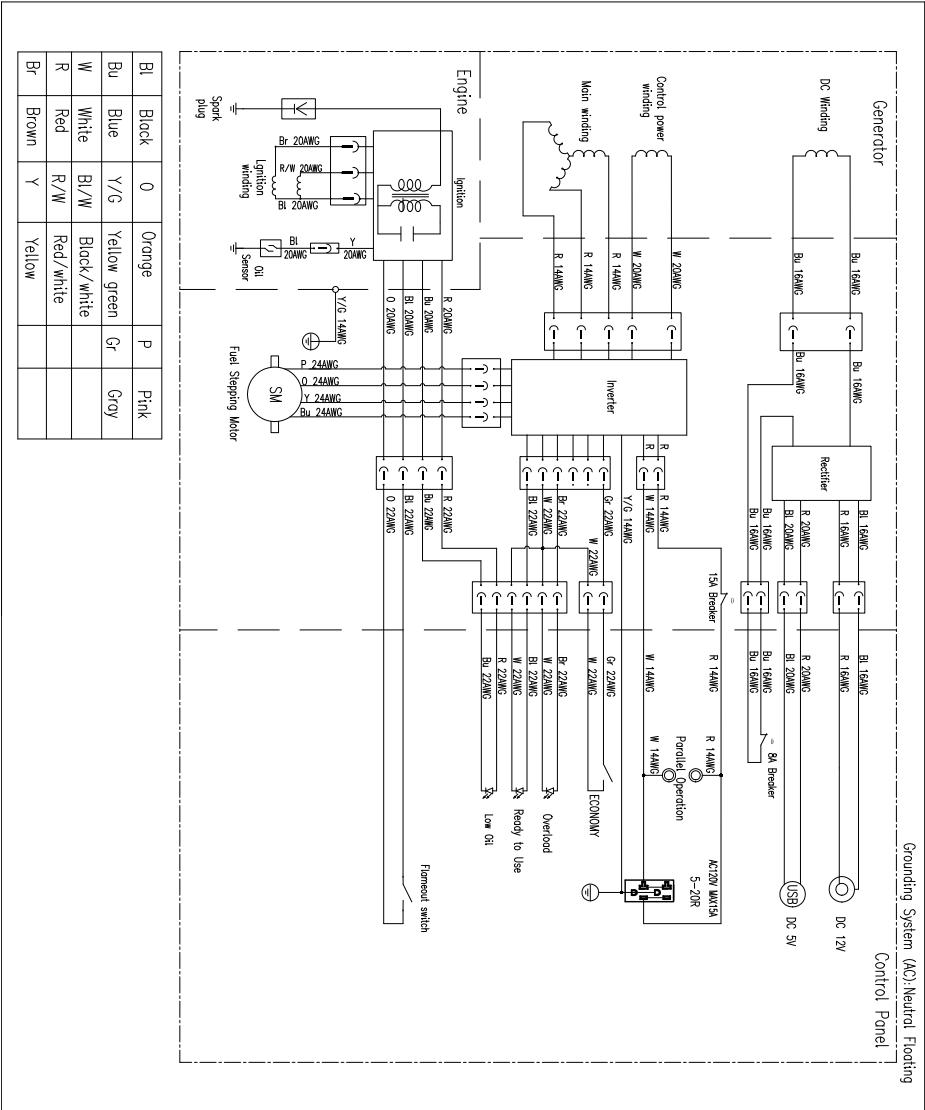

12. APPENDIX

The standard condition of rated power output:

Altitude: 0m

Ambient temperature: 77°F (25°C)

Relative humidity: 30%

Factor of Environment Correction:

Altitude (m)	Ambient Temperature°F (°C)				
	77° (25°)	86° (30°)	95° (35°)	104° (40°)	113 (45°)
0	1	0.98	0.96	0.93	0.90
500	0.93	0.91	0.89	0.87	0.84
1000	0.87	0.85	0.82	0.80	0.78
2000	0.75	0.73	0.71	0.69	0.66
3000	0.64	0.62	0.60	0.58	0.56
4000	0.54	0.52	0.50	0.48	0.46

NOTE:

Relative humidity 60% correction factor C-0.01

Relative humidity 80% correction factor C -0.02

Relative humidity 90% correction factor C-0.03

Relative humidity 100% correction factor C-0.04

Example:

Rated power (PN) 2.8kVA generator (Altitude: 1000m) Ambient temperature: 35°C,

Relative humidity: 80%

$$P=P_n*(C-0.02)=2.8*(0.82-0.02)=2.24kVA$$

13. LIMITED WARRANTY

This product is distributed by:
Midland Power Inc.
376 Magnetic Drive, Toronto, ON M3J 2C4, Canada

Warranty

Beginning at the time of retail purchase and for the duration of the warranty period Midland Power Inc. (Midland) warrants that Equipment manufactured by it is warranted to be free from defects in material and workmanship. Midland will, at its sole discretion, replace or repair any part(s) which, upon evaluation and testing by Midland or an authorized service center, show a defect in workmanship or material. Valid proof of purchase must be submitted online for registration with Midland, or presented to Midland at time of claim, for warranty to be valid. This warranty is not transferable from the original owner.

Limited Warranty Period:

Non-commercial use:

- Year 1, 2 and 3 - Parts and Labour
- Year 4 and 5 - Parts

Commercial use:

- First 6 Months - Parts and Labour

Replacement parts sold to a consumer or installed by an authorized service center are warranted for a period of 90 days from date of purchase. Labour must be performed by an authorized service center unless given Midland's prior written approval. Midland will not bear any transportation or shipping fees to or from an authorized service center. Service calls, travel charges, overtime, or weekend rates, are not covered.

This warranty does NOT cover:

- a. Any repairs required as a result of any parts not supplied by Midland, and this part is responsible for the failure or malfunction;
- b. Any Equipment modified, altered, disassembled or remodelled;
- c. Any repairs required as a result of a failure to install, maintain, store, transport, or operate the Equipment in accordance with standard practices set out in the user guide;
- d. Damage that occurred after receipt of equipment, not caused by defects in workmanship or material;
- e. Normal maintenance services, as outlined in the user guide and intended for a consumer to perform;

- f. Replacement of parts made in connection with normal maintenance services including oils, adhesives, additives, fuel, filters, brushes, belts, lubricants, spark plugs, gaskets, seals, fasteners, wires, tubes, pipes, fittings, wheels, batteries, and other expendables susceptible to natural wear;
- g. Any accessory or attachment.

Any battery supplied with this Equipment is considered a consumable item and is excluded from this warranty. Batteries can be damaged by shock, shorting terminals, heat, acid spillage, neglect, and other factors. It is the customer's responsibility to take great care when handling a battery so no spillage of acid occurs which may cause corrosion.

Midland disclaims any responsibility for loss of time or use of the product, transportation, or towing costs or any other indirect, incidental, or consequential damage, inconvenience or commercial loss.

This warranty is the entire and only warranty given by Midland for Midland products or equipment. No agent or employee is authorized to extend or enlarge this warranty on behalf of Midland by any written or verbal statement or advertisement.

California

The California Air Resources Board and Midland Power Inc. are pleased to explain the emission control system warranty on your Midland Power Inc. engine. In California, new spark-ignited small off-road equipment engines must be designed, built, and equipped to meet the State's stringent anti-smog standards.

Other States, U.S. territories, and Canada

In other areas of the United States and in Canada, your engine must be designed, built, and equipped to meet the U.S. EPA and Environment Canada emission standards for spark-ignited engines at or below 19 kilowatts.

All of the United States and Canada

Midland Power Inc. must warrant the emission control system on your power equipment engine for the period of time listed below, provided there has been no abuse, neglect, or improper maintenance of your power equipment engine. Where a warrantable condition exists, Midland Power Inc. will repair your power equipment engine at no cost to you including diagnosis, parts, and labor.

Your emission control system may include such parts as the carburetor or fuel injection system, the ignition system, and catalytic converter. Also included may be hoses, connectors, and other emission-related assemblies.

Emission Control System Warranty Parts:

This list applies to parts supplied by Midland Power Inc. and does not cover parts supplied by the equipment manufacturer. Please see the original equipment manufacturer's emissions warranty for non-Midland Power Inc. parts.

Consumable parts are covered up to a maximum of 30 days.

SYSTEMS COVERED IN WARRANTY	PARTS DESCRIPTION
Fuel Metering	Carburetor assembly (includes starting enrichment system), Engine temperature sensor, Engine control module, Fuel regulator, Intake manifold
Evaporative	Fuel Tank, Fuel Cap, Fuel Hoses, Vapor Hoses, Carbon Canister, Canister Mounting Brackets, Fuel Strainer, Fuel cock, Fuel Pump, Fuel Hose Joint, Canister Purge Hose Joint
Exhaust	Catalyst, Exhaust Manifold
Air Induction	Air filter housing, Air filter element
Ignition	Flywheel magneto, Ignition pulse generator, Crankshaft position sensor, Power coil, Ignition coil assembly, Ignition control module, Spark plug cap, Spark plug
Crankcase Emission Control	Crankcase breather tube, Oil filler cap
Miscellaneous Parts	Tubing, fittings, seals, gaskets, and clamps associated with these listed systems

Enjoy!

Be sure to check www.benchmark.midlandpowerinc.com for updates regarding your product.





Customer Service

Online: www.benchmark.midlandpowerinc.com

E-mail: support@midlandpowerinc.com

Toll Free: 1-877-528-3772



BENCHMARKTM_{MC}

BG2300Di