

BENCHMARK™

15,000W TRI-FUEL GENERATOR WITH REMOTE START

5210-153



OWNER'S MANUAL



This product is supported by **Midland Power**. Contact us directly for assistance and warranty help. Do not return this product to store.

You must register online for your warranty to be valid. It only takes a minute, do it now while you still have your purchase receipt.

Register Your Product Online

[www.benchmark.midlandpowerinc.com/
register-warranty](http://www.benchmark.midlandpowerinc.com/register-warranty)



Support for your product is available online, including parts, service center locations, and live expert advice.

Visit us online at

www.benchmark.midlandpowerinc.com



Or call us anytime at **1-877-528-3772**.

Thanks for choosing Benchmark!

You're excited to get started, we'll keep this brief.

READ THIS ENTIRE GUIDE BEFORE USING THIS PRODUCT AND SAVE FOR LATER USE.

This user guide contains important instructions including safety, setup, operation, and maintenance that must be followed. All information in this guide is based on information available at the time of print. This guide or revised editions can be found on our website for download. No part of this publication may be reproduced without written permission.

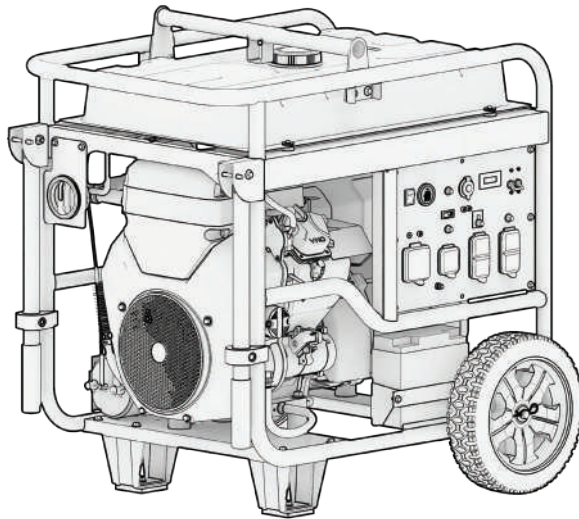

THIS PRODUCT MEETS ALL CERTIFICATION REQUIREMENTS FROM:



The engine exhaust from this product contains chemicals known to cause cancer, birth defects or other reproductive harm.

©2025 Benchmark. All Rights Reserved.

5210-153_Manual_EN_2025-01-08

TABLE OF CONTENTS

1. Safety	1
2. Learn About Your Generator	5
3. Pre-Operation Check	10
3.1 Prepare the Air Filter	10
3.2 Check the Oil Level	11
3.3 Check the Fuel Level	13
3.4 Check the LP Gas Cylinder Connection	14
3.5 Check the Natural Gas Supply Connection	15
3.6 Electric Start Battery Connection	16
4. Using Your Generator	17
4.1 Starting your Tri-fuel Generator	18
4.2 Using Your Appliances	23
4.3 Stopping the Engine	24
5. Folding the Handle	26
6. Maintenance	27
6.1 Maintenance Schedule	28
6.2 Emission Control System	29
6.3 Changing the Oil	31
6.4 Cleaning the Air-Filter	33
6.5 Spark Plug Service	34
6.6 Spark Arrester Maintenance	36
6.7 Fuel Filter Maintenance	36
6.8 How to Sync a New Remote (Remote Pairing)	37
6.9 Carburetor Modification for High Altitude Operation	38
7. Transportation & Storage	40
8. Troubleshooting	43
9. Technical Specifications	45
11. Appendix	46
12. Wiring Diagram	47
13. Limited Warranty	48

1. SAFETY

⚠ DANGER	
Using a generator indoors CAN KILL YOU IN MINUTES . Generator exhaust contains carbon monoxide. This is a poison you cannot see or smell.	
 NEVER use inside a home or garage, EVEN IF doors and windows are open.	 Only use OUTSIDE and far away from windows, doors, and vents.
Avoid other generator hazards. READ MANUAL BEFORE USE.	

⚠ DANGER! ⚠

Using a generator indoors can kill you in minutes.

The engine exhaust from this product contains chemicals known to cause cancer, birth defects or other reproductive harm.

1.1 OPERATOR SAFETY

⚠ WARNING!

- Always perform an oil, fuel and air filter check before starting the engine.
- Properly clean and maintain the equipment.
- Operate the generator according to instructions for safe and dependable service.
- Before operating the generator, read the user guide carefully. Otherwise, it may result in personal injuries or equipment damage.
- Never run the generator in an enclosed area to avoid harm from exhaust emissions of a poisonous carbon monoxide gas.
- Be careful not to touch the exhaust system during operation due to risk of burns.
- Pay attention to the warning labels. The engine exhaust system will become heated during operation and remain hot immediately after the engine is stopped.
- Gasoline is a highly flammable and explosive liquid. Refuel in a well ventilated area with the engine stopped.
- Use of gasoline with an ethanol content greater than 10% can damage the engine and fuel system and will void the manufacturer's warranty.
- When refueling the generator, keep it away from cigarettes, open flames, smoke and/or sparks.

- Place the generator at least 10 feet away from buildings or other equipment during operation.
- Run the generator on a level surface. Tilting the generator may result in fuel spills.
- Know how to stop the generator quickly and understand operation of all the controls. Never permit anyone to operate the generator without proper instructions.
- Keep children, pets and machinery with rotating parts away during operation.
- Do not operate the generator in rain or snow.
- Do not allow any moisture to come in contact with the generator.
- Do not touch the spark plug while the engine is operating or shortly after the engine has been shut down.

1.2 AC SAFETY

WARNING!

Before connecting the generator to an electrical device or power cord:

- Make sure that everything is in proper working order. Faulty devices or power cords can lead to an electrical shock.
- Turn off the generator immediately if the device begins to operate abnormally. Then disconnect the device and investigate the problem.
- To prolong engine life, make sure that the combined load of your devices does not exceed the rated running wattage of the generator.
- Connections for standby power to a building's electrical system must be done by a qualified electrician and must comply with all applicable laws and electrical codes. Improper connections may cause serious injuries to electrical workers during a power outage, and when the utility power is restored, the generator may explode or cause fires. The generator shall be connected through transfer equipment that switches all conductors other than the equipment grounding conductor. The frame of the generator must be connected to an approved grounding electrode.
- Generator is neutral bonded to frame. There is a permanent conductor between the generator (stator winding) and the frame.
- Electrical devices that require a grounded receptacle pin connection will not function if the receptacle ground pin is not functional.

1.3 PROPANE SAFETY

⚠ WARNING!

- Propane is a Liquid Petroleum Gas (LPG) which is highly flammable and explosive.
- Do not store or use LPG in an enclosed area.
- Do not expose the LPG cylinder to excessive heat.
- Fully close the LPG cylinder when the generator is not in use or is running with gasoline.
- Never use a gas container, LPG connector hose, LPG cylinder or any other fuel item that appears damaged.
- If you smell gas, close the gas supply and check all connections for leaks before attempting to use the generator again.
- Keep the LPG cylinder in an upright position.
- Keep a fire extinguisher near the generator all the time.

1.4 MAINTENANCE SAFETY

⚠ WARNING!

- After any maintenance is performed, wash hands immediately using soap and clean water because repeated exposure to lubricant may cause skin irritation.
- Do not clean the filter element with flammable liquids like gasoline because an explosion may occur.
- Turn off the engine and allow the generator to cool down before performing any maintenance. Failure to do so can cause severe personal injury or death.
- Always wear safety glasses when cleaning the generator set with air.
- Do not clean the generator set with a pressure washer because it can cause damage to the generator set.
- When working with batteries, ventilate the area, use safety glasses, do not smoke. Always disconnect the negative first and reconnect it last.
- Use rubber gloves when coming into contact with engine oil.
- Always stop the generator set before removing the oil filler cap.
- Only qualified maintenance personnel with knowledge of fuels, electricity, and machinery hazards should perform maintenance procedures.
- See 'Maintenance Schedule' for the recommended maintenance schedule.

1.5 OTHER SAFETY TIPS

⚠ WARNING ⚠
AVERTISSEMENT

 **TOXIC FUMES HAZARD.** Running engines give off carbon monoxide, an odourless poisonous gas that can cause nausea, fainting, or death. Do not start engine indoors or in an enclosed area, even if the windows and doors are open.

DANGER TOXIQUE. Faire fonctionner un moteur dégage de l'oxyde de carbone, un gaz inodore toxique qui peut provoquer la nausée, évanouissement ou la mort. Ne pas démarrer le moteur à l'intérieur ou dans une espace clos, même si les fenêtres et les portes sont ouvertes.

⚠ WARNING!

- To avoid breathing in poisonous carbon monoxide from the exhaust gases, adequate ventilation should be provided, only operate the generator outside and away from enclosed areas, windows, and doors.
- If the generator set is stored outdoors, check all the electrical components on the control panel before each use. Moisture can damage the generator and can lead to an electric shock.
- Generators vibrate in normal use. During and after the use of the generator, inspect the generator as well as extension cords and power supply cords connected to it for damage resulting from vibration. Have damaged items repaired or replaced as necessary. Do not use plugs or cords that show signs of damage such as broken or cracked insulation or damaged blades.
- If you start to feel sick, dizzy, or weak after the generator has been running, move to fresh air **RIGHT AWAY**. See a doctor. You could have carbon monoxide poisoning.

2. LEARN ABOUT YOUR GENERATOR

This section will show you how to identify key parts of your generator. Going over the terminology below will make sure we're on the same page.

2.1 COMPONENT IDENTIFICATION

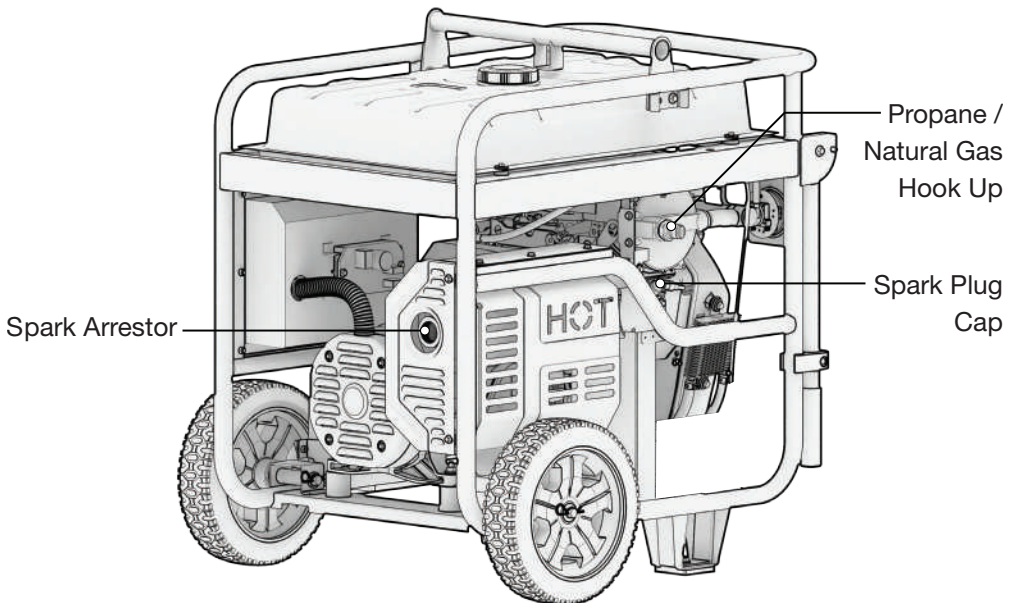
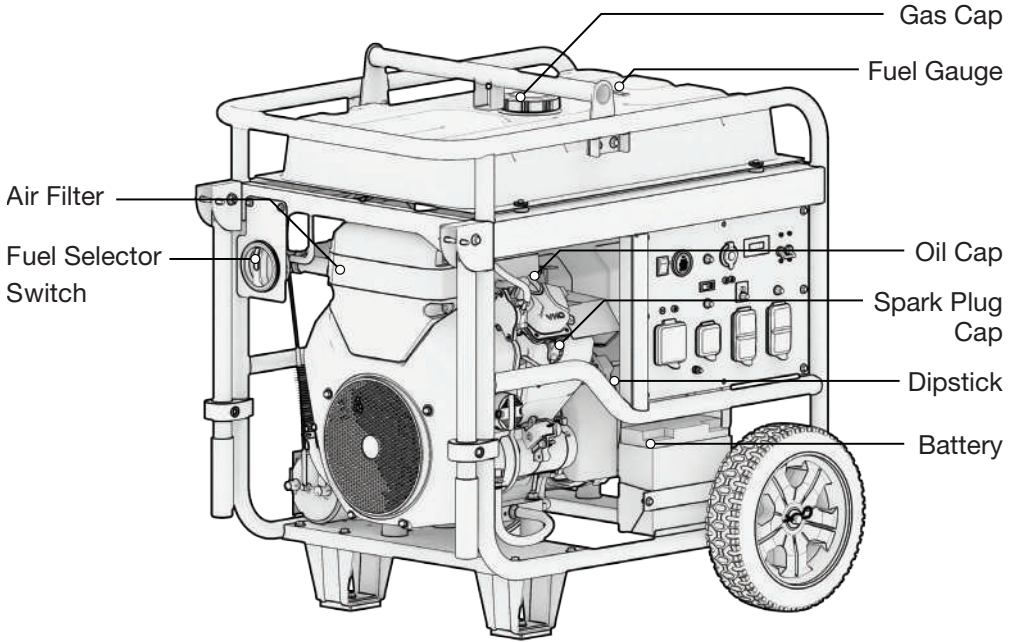

2.2 CONTROL PANEL

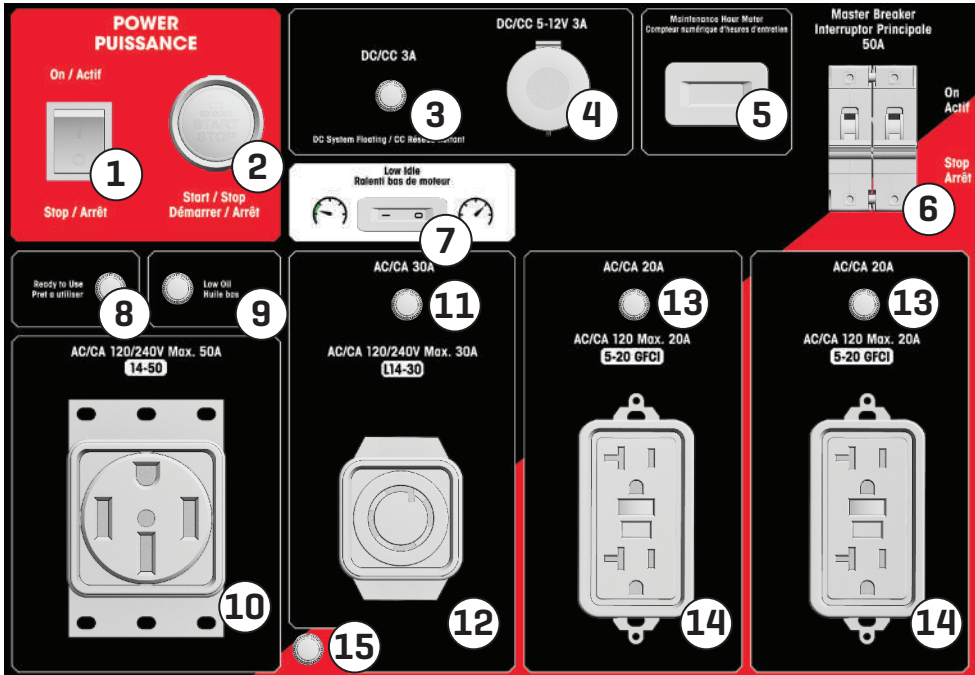

- | | |
|---------------------------------|----------------------------------|
| 1. Power Switch | 9. Low Oil Indicator |
| 2. Electric Start / Stop Switch | 10. 120/240V 50A (14-50) Outlet |
| 3. DC 3A Breaker | 11. 30A AC Breaker |
| 4. DC 5-12V 3A Outlet | 12. 120/240V 30A (L14-30) Outlet |
| 5. Maintenance Hour Meter | 13. 20A AC Breaker |
| 6. 50A Master Breaker | 14. 120V 20A (5-20) GFCI Outlet |
| 7. Low Idle Switch | 15. Ground Terminal |
| 8. Ready to Use Indicator | |

2.3 CONTROL FUNCTIONS

AC Circuit Breakers

- While the generator is running, the breakers should be in the ON position.
- If the current has exceeded its limits the breaker will automatically pop out to the OFF position. Reduce the electrical load on the generator and push the button back to the ON position.

Battery Charging Port

- When the generator will be stored for an extended period of time plug the battery charger into a 120V outlet every two months to top up the battery and prolong its life.

Fuel Selector Switch

- Switches between gasoline or propane (LPG) fuel or natural gas (NG) sources.

Ground Terminal

⚠ WARNING!

Before using the ground terminal consult a qualified electrician, electrical inspector, or local agency having jurisdiction for local laws and codes that apply to the intended use of the generator.

- Generator is neutral bonded to frame.
- The ground terminal is connected to the non-current carrying metal parts (such as the fuel tank), the frame, and the ground terminals of the AC outlets.

Hour Meter

- Always on display shows total run time. Perform maintenance at the proper intervals according to the 'Maintenance Schedule' section of this manual.

Low Oil Indicator Light

- The oil alert system is designed to prevent engine damage caused by an insufficient amount of oil in the crankcase. Before the oil level in the crankcase reaches an unsafe limit, the oil alert system will automatically shut down the engine (the power switch remains in the ON position).
- If the oil alert system shuts down the engine, the low oil indicator light (red) will turn on. Check the engine oil level.

Remote

- Start your generator from up to 100 feet away.

2.3 ASSEMBLY INSTRUCTIONS

Setup of your BG generator is designed to get you up and running as quickly as possible. If equipped with your generator, install the wheel, handle, and feet kits, then continue on to Chapter 3.

1. Install the wheels, foot, and handle as shown below.

NOTE

- Add engine oil and clean the air filter before starting the engine.

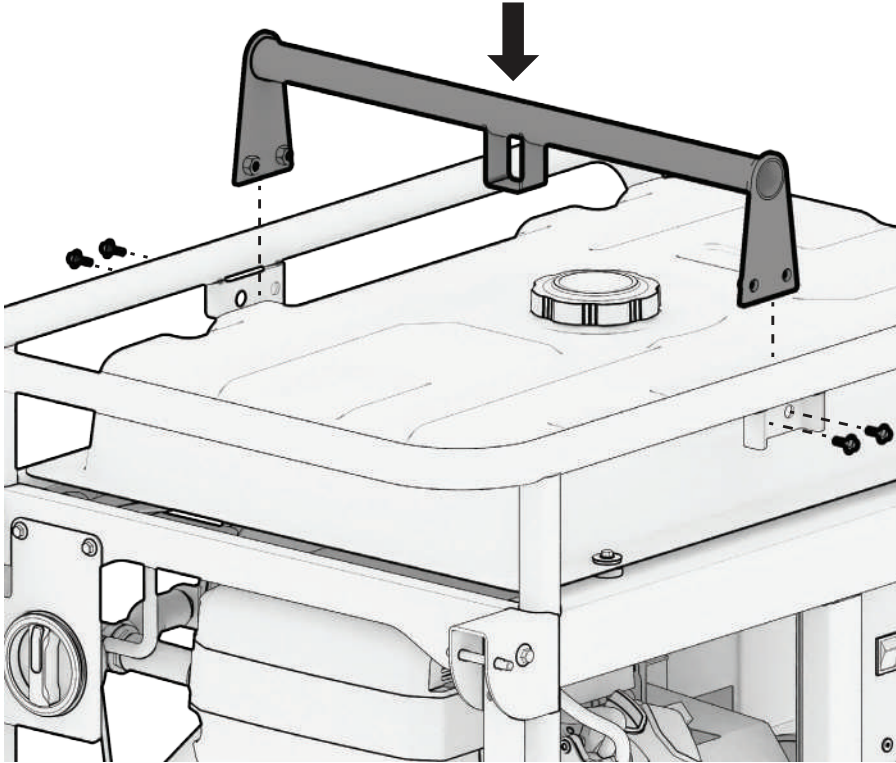

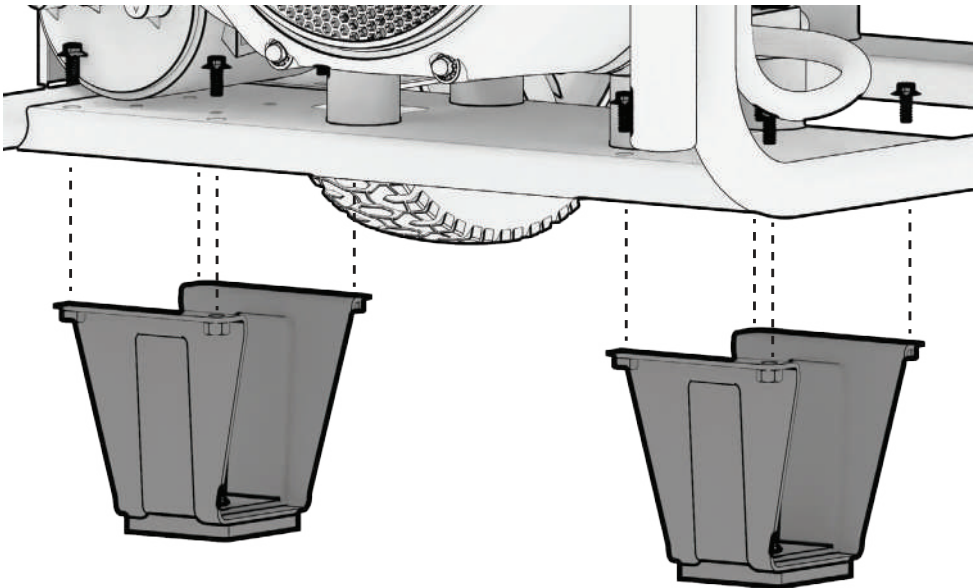
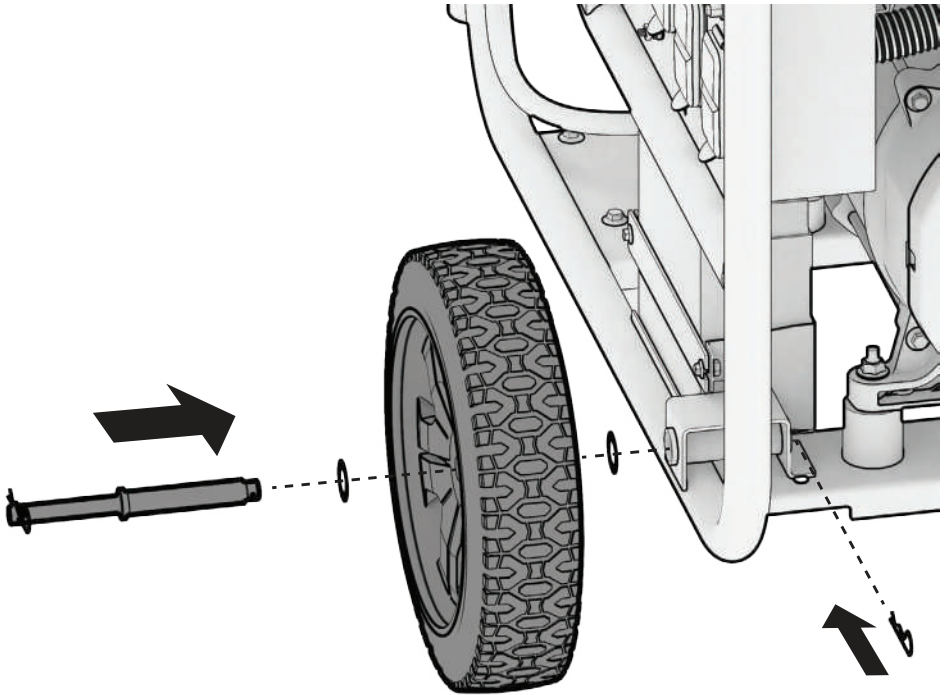

3. PRE-OPERATION CHECK

These quick checks should be done each time the generator is started to ensure you get the most out of your generator.

Set the generator on a level surface and the power switch to STOP.

NOTE

- DO NOT soak air filter in oil.
- Running the engine without the air filter will quickly degrade the engine.
- Always inspect air filter before using the generator. Check and clean the air filter according to the maintenance schedule.

3.1 PREPARE THE AIR FILTER

Clean the air filter before your first use. Check the maintenance schedule for a complete cleaning guide.

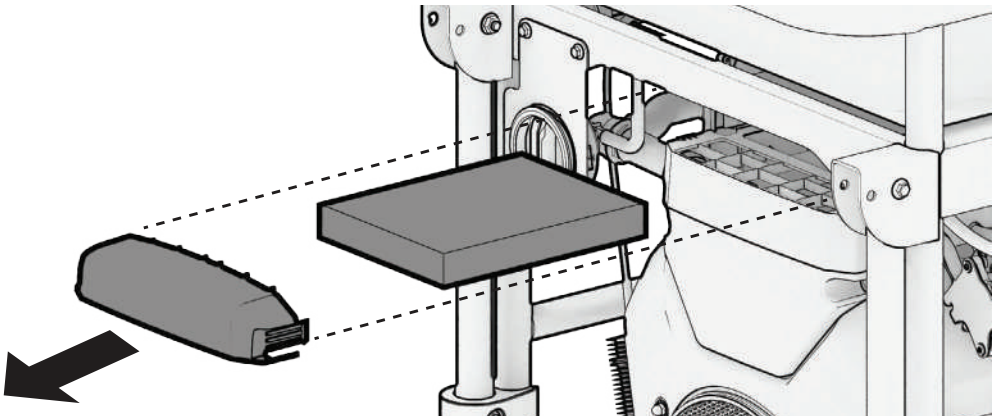

1. Press side tabs and remove the air filter cover. Remove the *foam* air filter element and inspect for cleanliness. Replace the filter if it is damaged.
2. Clean the *foam* air filter with soap and water or solvent and let dry.
3. Re-install air filter and air filter cover.

3.2 CHECK THE OIL LEVEL

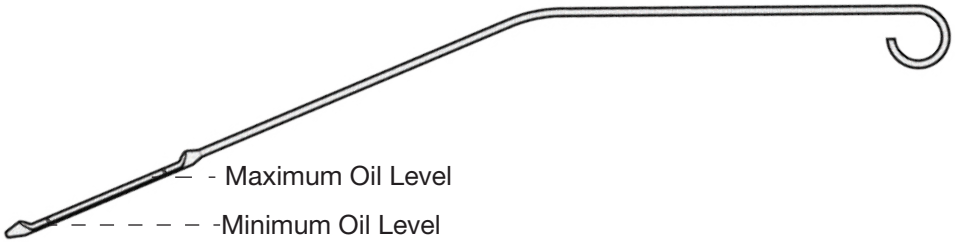
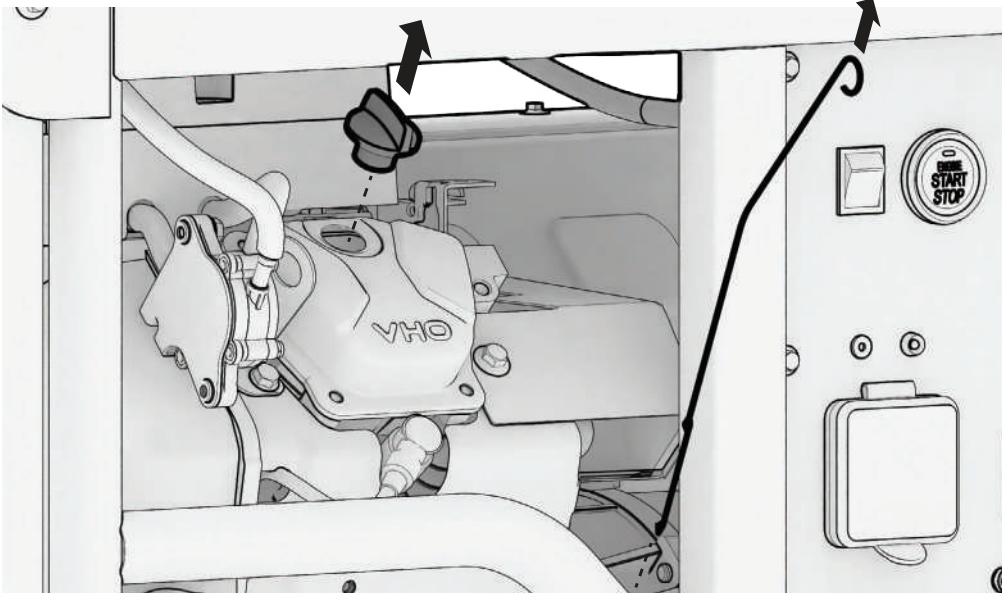

1. Ensure the generator is on a level surface.
2. Unscrew the oil cap and clean the dipstick.
3. Check the oil level by inserting the dipstick. Remove the cap and examine the oil level on the dipstick. If the level is at or below the minimum oil level marked on the dipstick, refill to the maximum oil level mark.
4. Reinsert the oil cap and tighten securely.

Effective Viscosity Range of Engine Oils

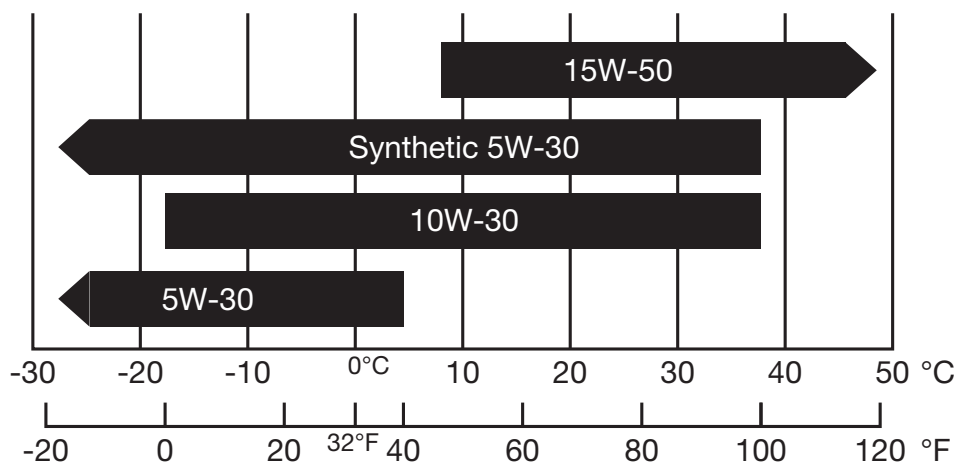

NOTE

- Maximum Oil capacity: 1.5 L
- Do not tilt the generator when adding engine oil. This could result in overfilling and damage to the engine.
- Using non-detergent or 2-stroke oil could shorten the engine's working life.
- Use high quality engine oil with strong detergents.
- Handle and store the engine oil with care, avoid getting dirt or dust into the engine oil.
- Do not mix different engine oils.
- Before the engine oil falls below the safety margin, the low oil alert system will automatically shut off the engine. The low oil light will turn on.
- To avoid the inconvenience of unexpected engine shutoff, check the engine oil level as often as possible.
- Use 4-stroke engine oil, certified to meet or exceed API standard SG, SF, SAE ratings.

3.3 CHECK THE FUEL LEVEL

⚠ WARNING!

Gasoline is highly flammable and explosive under certain conditions. Refuel in a well-ventilated area with the engine stopped. Do not smoke or allow open flames or sparks in the area where the generator is being refueled or where gasoline is stored. Do not overfill the tank. Be careful not to spill fuel when refueling. Wipe up any spilled gasoline and let the area dry before starting the engine.

Gasoline substitutes such as gasohol are not recommended. They may be harmful to the fuel system components.

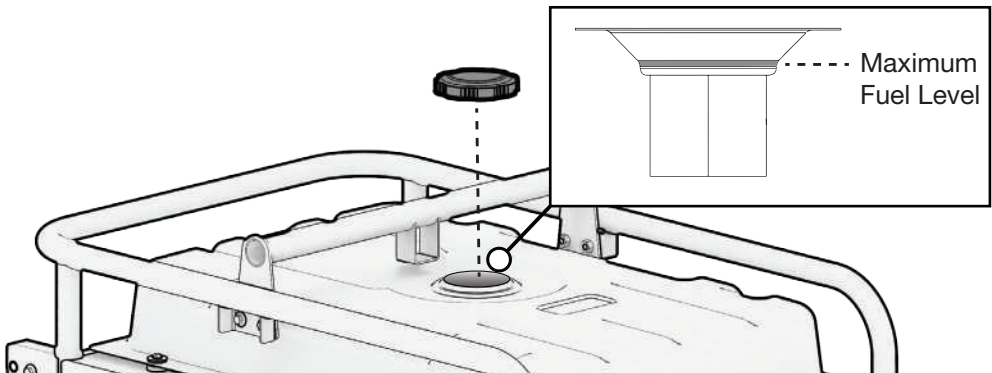

1. Check the fuel level by reading the gauge or removing the fuel tank cap to visually check the level.
2. Add fuel. Tighten the fuel cap securely after refilling.

NOTE

- Maximum Gasoline Capacity: 40 L
- Only use unleaded gasoline (Pump Octane 87 or higher).
- Never use stale or contaminated gasoline, or an oil/gasoline mixture.
- Avoid getting dirt or water into the fuel tank.
- Do not use a mixture of gasoline containing methanol. This will cause serious damage to the engine.
- Use of gasoline with an ethanol content greater than 10% can damage the engine and fuel system and will void the manufacturer's warranty.

3.4 CHECK THE LP GAS CYLINDER CONNECTION

⚠ DANGER! ⚠

Fire and explosion hazard. Never connect or disconnect the Liquid Petroleum Gas (LPG)/propane hose while the engine is running. Do not smoke or create sparks while handling LPG/propane. Always turn the engine off and allow the generator to cool for at least five minutes before connecting the propane cylinder.

⚠ WARNING!

Never use a gas container, LPG/propane hose, propane cylinder or any other fuel item that appears to be damaged.

To reduce the risk of injury, perform a leak test any time the LP gas cylinder is disconnected and reconnected. Do not connect or disconnect the LP gas cylinder indoors. Do not place the LP gas cylinder in the path of the muffler exhaust.

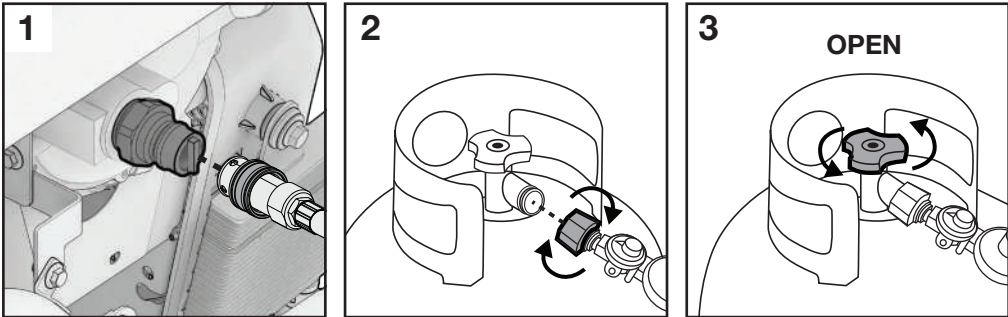

1. Connect the propane hook up to the intake nozzle of LPG hose (included).
2. Ensure the handwheel on the LPG hose is in the OFF position. Connect the other end of the hose to the propane cylinder.
3. Open the valve on the propane cylinder.

3.5 CHECK THE NATURAL GAS SUPPLY CONNECTION

⚠ DANGER! ⚠

Fire and explosion hazard. Never connect or disconnect the natural gas hose while the engine is running. Do not smoke or create sparks while handling natural gas. Always turn the engine off and allow the generator to cool for at least five minutes before connecting to natural gas.

⚠ WARNING!

Never use a natural gas supply line, natural gas hose, or any other fuel item that appears to be damaged.

To reduce the risk of injury, perform a leak test any time the natural gas hose is disconnected and reconnected.

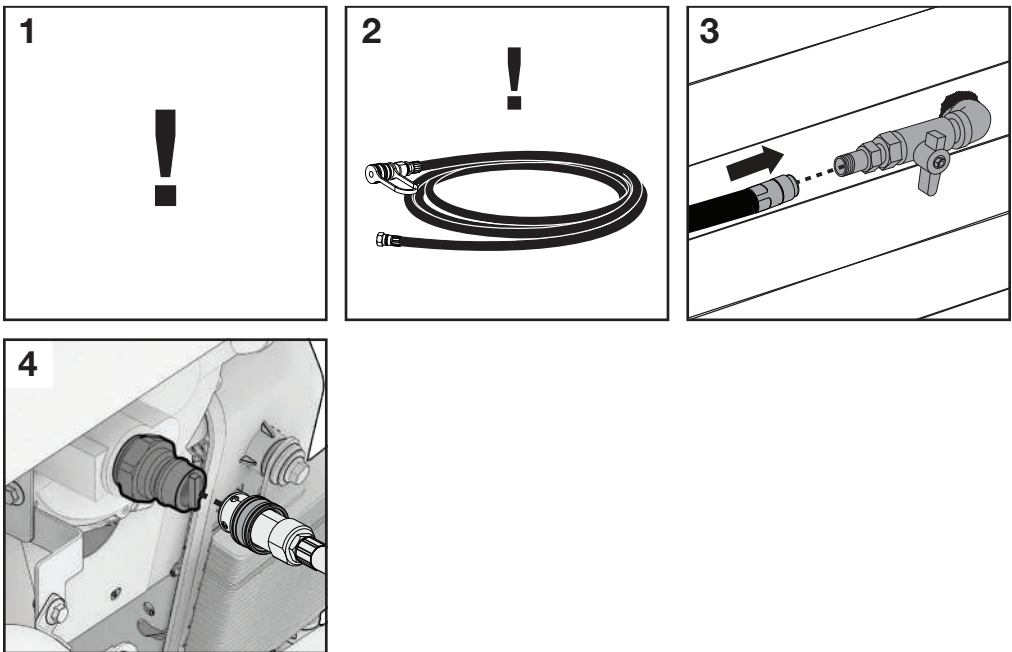

1. Verify that the gas is turned off at the natural gas supply line.
2. Completely unwrap and straighten the natural gas hose to prevent any kinks.
3. Attach the hose to the natural gas supply line, hand tighten only. **DO NOT** use sealants. Do not cross-thread.
4. Connect the natural gas hose to the generator using the quick-connect collar.

3.6 ELECTRIC START BATTERY CONNECTION

⚠ WARNING!

Batteries produce explosive gases. Keep sparks, flames and cigarettes away from the battery at all times.

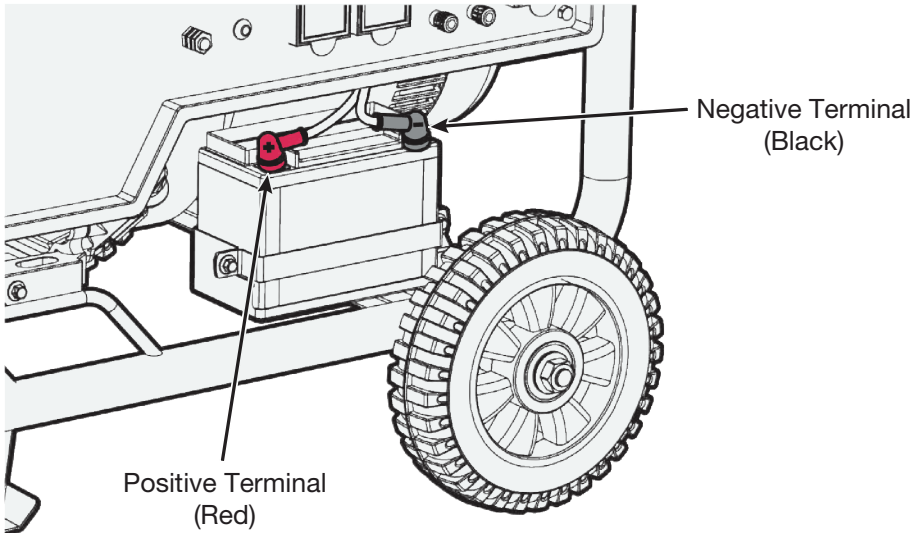



1. Connect the red cable to the positive terminal of the battery. Ensure the connection is secured by using the fastener at the battery terminal.
2. Connect the black cable with the negative terminal of the battery. Ensure the connection is secured by using the fastener at the battery terminal.

NOTE

- The onboard electric start battery recharges while the generator is running.
- Be sure to connect the electric start battery to the generator set before operation. Do not reverse the polarity of the terminals when charging the battery. Serious damage to the generator and/or battery may occur. Do not attempt to connect the battery while the generator engine is running. Disconnect the cables from the battery while the generator is in storage.

4. USING YOUR GENERATOR

⚠ DANGER	
Using a generator indoors CAN KILL YOU IN MINUTES . Generator exhaust contains carbon monoxide. This is a poison you cannot see or smell.	
 	
NEVER use inside a home or garage, EVEN IF doors and windows are open.	Only use OUTSIDE and far away from windows, doors, and vents.
Avoid other generator hazards. READ MANUAL BEFORE USE.	

⚠ DANGER! ⚠

Using a generator indoors WILL KILL YOU IN MINUTES.

Generator exhaust contains high levels of carbon monoxide (CO), a poisonous gas you cannot see or smell. If you can smell the generator exhaust you are breathing CO. Even if you cannot smell the exhaust, you could be breathing CO.

NEVER use a generator inside a home, garage, crawlspace, or other partly enclosed area, deadly levels of carbon monoxide can build up in these areas. Using a fan or opening windows and doors will **NOT** supply enough fresh air.

ONLY use a generator outdoors and far away from open windows, doors, and vents. These openings can pull in generator exhaust. Even when you use a generator correctly, CO may leak into the home. **ALWAYS** use a CO alarm in your home.

If you start to feel sick, dizzy, or weak after the generator has been running, move to fresh air **RIGHT AWAY** and seek medical attention. You could have carbon monoxide poisoning. **Never** run the generator in an enclosed or even partially enclosed area where people may be present.

⚠ WARNING!

Before using the generator, a ground wire may need to be connected to the ground terminal. The terminal is located on the front panel. Before using the ground terminal consult a qualified electrician.

4.1 STARTING YOUR TRI-FUEL GENERATOR

DANGER!

Liquid Petroleum Gas (LPG) and Natural Gas (NG) are highly flammable. Do not store or use LPG or NG in an enclosed area. Do not expose the LPG cylinder to excessive heat. Fully close the LPG cylinder or NG line when the generator is not in use or is running with gasoline. Never use a gas container, LPG or NG connector hose, LPG cylinder or any other fuel item that appears damaged.

If you smell gas, close the gas supply and check all connections for leaks before attempting to use the generator again.

NOTE

- The choke is automatically controlled during remote start, but must be manually operated during electric or recoil start.
- Check the LPG and NG connections for leaks by wetting the hose fittings with soapy water. If bubbles appear or grow in these fittings, there is a leak. Turn off all valves and tighten the connections. Turn valves back on and recheck with soapy water. Do not use the generator and contact customer service if the leak continues or if it is not possible to identify the source of the leak.
- Do not push the choke lever to the START/CLOSED position when the engine is hot or ambient air temperature is high.
- If recoil starting, return the starter grip slowly by hand, do not let it snap back.
- If there is no electric-start battery in the generator or the battery has died, the generator can only be started using the recoil method. If there is a battery and it is drained, running the generator will recharge the battery.

4.1.1 FUEL SELECTION

Gasoline Selection

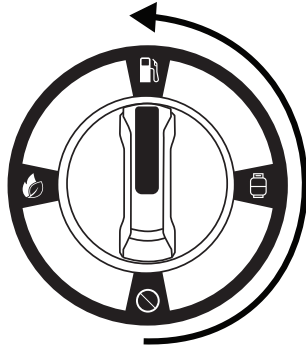

1. Turn the Fuel Selector on the panel to GASOLINE.

Propane (LPG) Selection and Propane Cylinder Connection

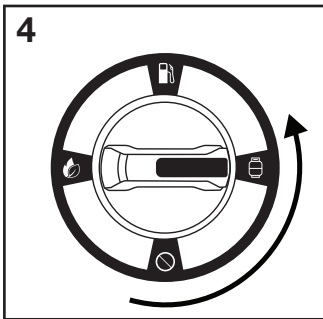
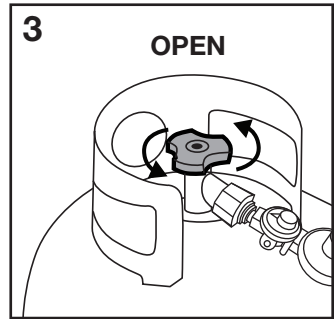
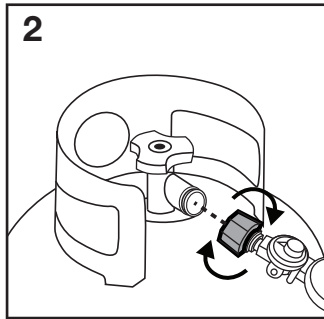
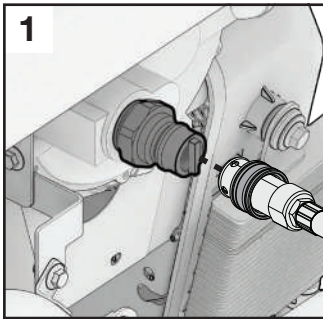

1. Connect the propane hook up to the intake nozzle of LPG hose (included).
2. Connect the other end of the hose to the propane cylinder.
3. Open the valve on the propane cylinder.
4. Turn the Fuel Selector on the panel to PROPANE.

Natural Gas Selection and Connection

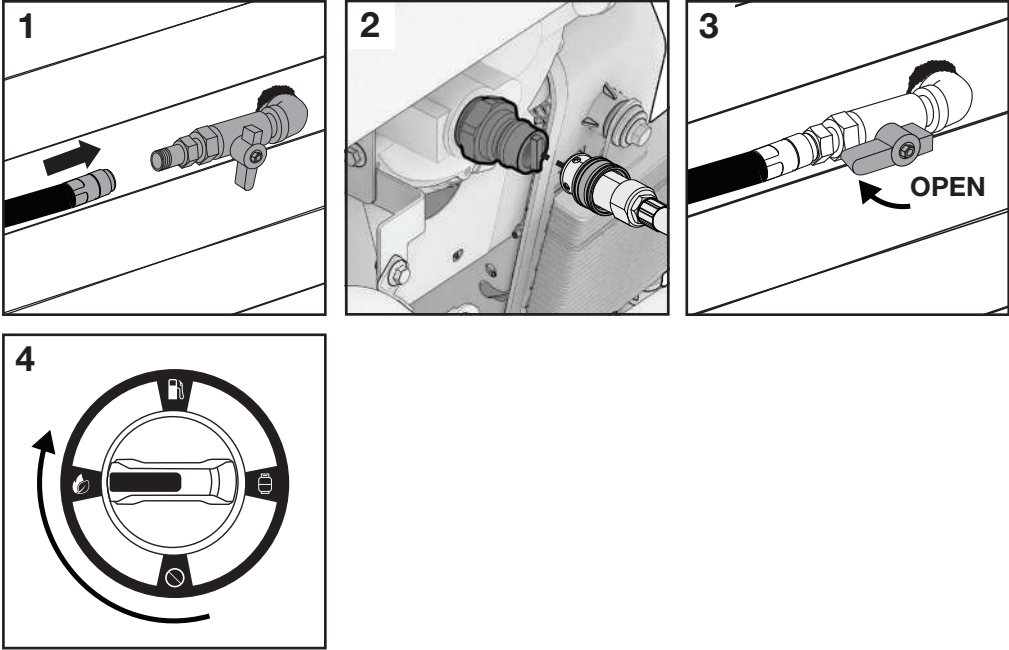

1. Connect the natural gas hook up to the intake nozzle of NG hose (included).
2. Connect the other end of the hose to the NG supply line.
3. Open the valve on the natural gas supply line.
4. Turn the Fuel Selector on the panel to NATURAL GAS.

4.1.2 REMOTE START

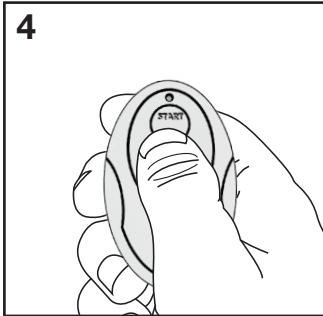
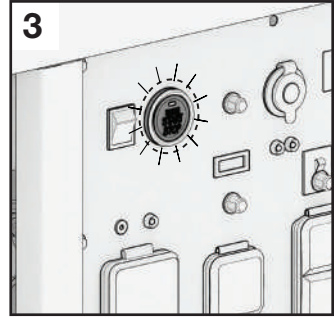
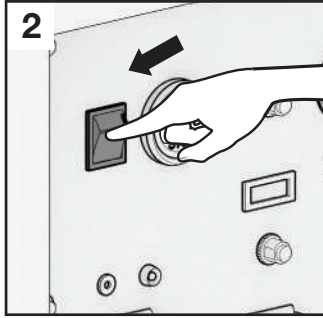
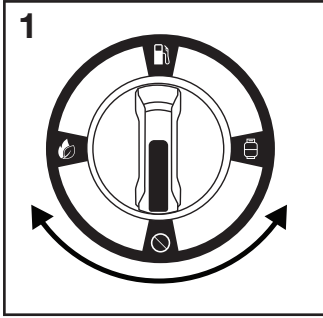

1. Choose your fuel source by following section 4.1.1
2. Push the power switch to the ON position.
3. Wait for the Remote Start Ready light to turn on.
4. Within the remote start standby time of your model, press the remote's START button to start the generator

NOTE

- Remote standby time is 14 days.

4.1.3 ELECTRIC START

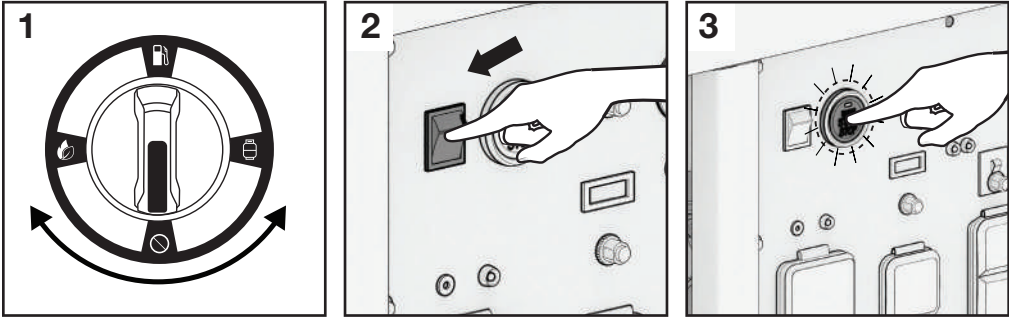

1. Choose your fuel source by following section 4.1.1
2. Turn the power switch to the ON position.
3. Press and hold the START button for 1 second, or until the generator starts, then release it.

4.2 USING YOUR APPLIANCES

Before starting make sure you know what you can power with your generator.

Here's how you can decide:

Add the watt ratings of all loads the generator will be powering at the same time. Make sure the total wattage will not exceed the generator's rating.

EXAMPLE:

A generator set rated 5000W can power two 1500W heaters, a 900W circular saw, a 500W drill and a 100W light at the same time (4500W combined). However, to operate an extra 900W saw, it will be necessary to disconnect one of the 1500 W heaters.

NOTE

- To stop the engine in an emergency, turn the engine switch to STOP. Always connect the generator to the ground terminal to prevent electrical shock.

4.3 STOPPING THE ENGINE

Normal Operation (Gasoline)

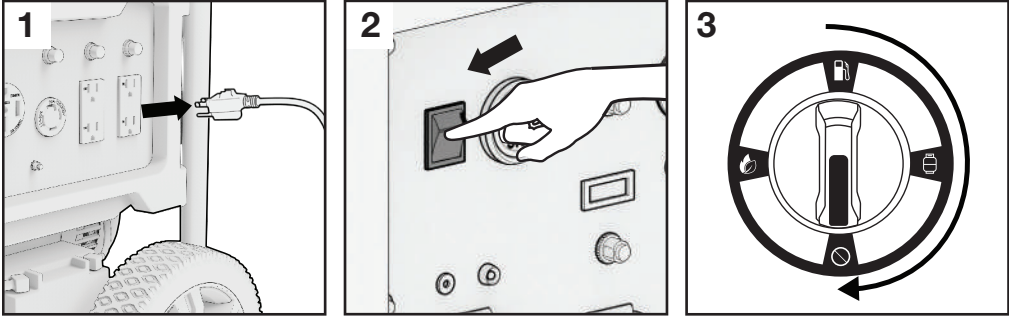

1. Switch off the connected electrical appliances, and disconnect them from the generator.
2. Turn the power switch to the STOP position.
3. Turn the fuel valve to the CLOSED position.

Normal Operation (Propane)

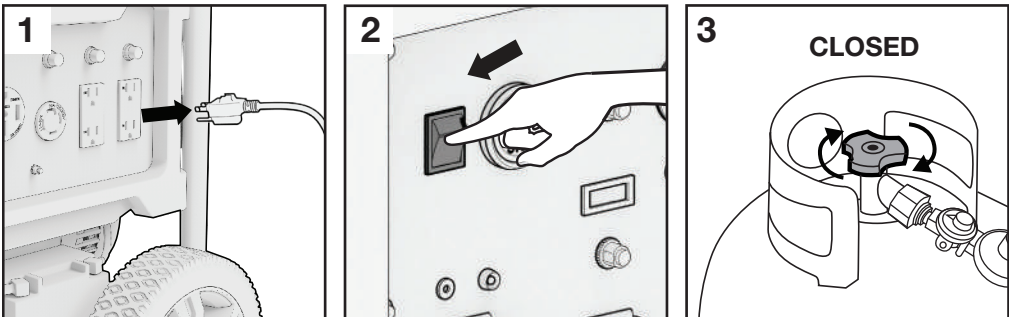

1. Switch off the connected electrical appliances, and disconnect them from the generator.
2. Turn the power switch to the STOP position.
3. Close the supply valve on the propane cylinder.

Normal Operation (Natural Gas)

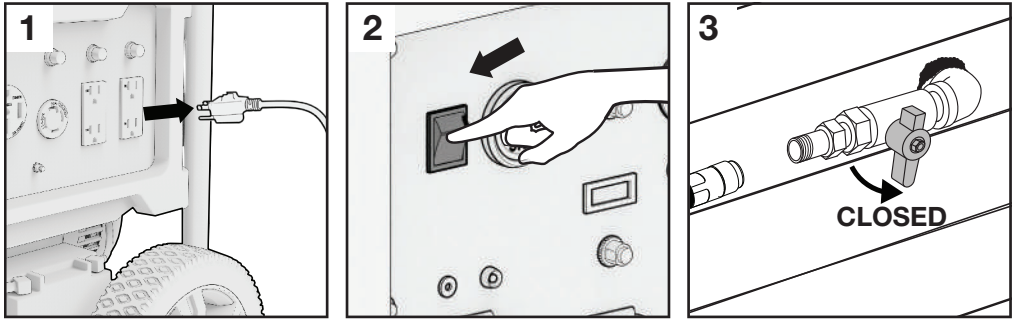

1. Switch off the connected electrical appliances, and disconnect them from the generator.
2. Turn the power switch to the STOP position.
3. Close the supply valve on the natural gas line.

Emergency Stop

1. To stop the engine in an emergency, turn the power switch STOP immediately.

NOTE

- Make sure the fuel valve and engine switch are in the STOP position when stopping, transporting, and storing the generator.

5. FOLDING THE HANDLE

The handle folds down for compact storage and locks up into position for easy maneuvering.

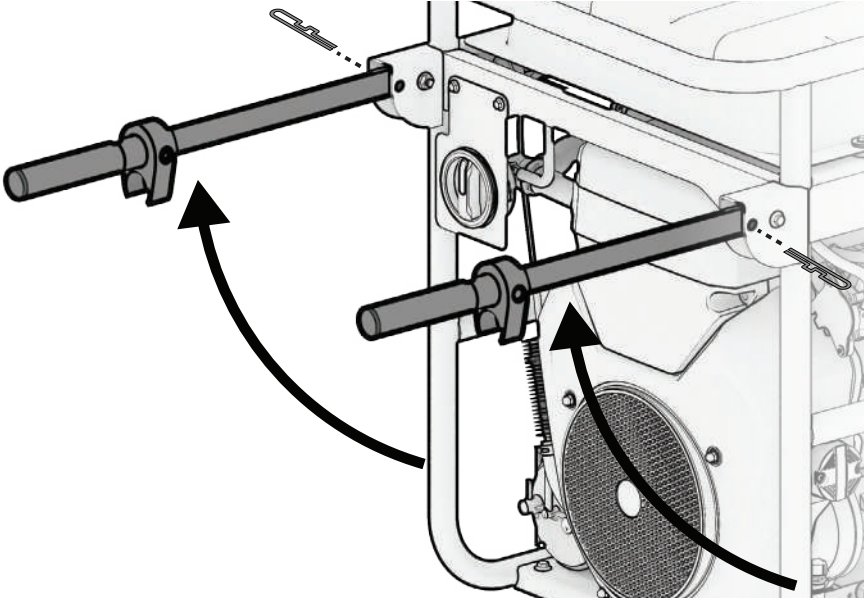

1. Pull up the handle into the upright position.
2. Insert the locking pin on both sides.

6. MAINTENANCE

Proper maintenance keeps your generator in the best operating condition by ensuring safe, economical and trouble-free operation. Only use genuine parts and recommended fluids to replace the worn components. Improper maintenance may cause the generator to malfunction and can lead to serious injury. Contact customer support if you have any maintenance questions.

General Inspection Tips

- Look for fuel leaks around the fuel tank, fuel hose, and fuel valve. Close the fuel valve and repair leaks immediately.
- Look and listen for exhaust leaks while the engine is running. Have all the leaks repaired before continuing operation.
- Check for dirt and debris and clean as necessary .
- Check the engine oil level and add oil as necessary.

6.1 MAINTENANCE SCHEDULE

Regular maintenance will improve performance and extend the service life of the generator. Maintain the generator according to the maintenance schedule below.

NOTE

- Service more frequently when used in dusty areas or adverse conditions.
- These items should be serviced by an authorized service center, unless you have the proper tools and are mechanically proficient. Refer to user guide for service procedures.

Before Each Use
Check engine oil level Inspect air filter
First 5 Hours or First Month
Change engine oil
Every 50 Hours or 6 Months
Check and clean air filter ¹
Every 100 Hours or 12 Months
Change engine oil ² Inspect/clean spark arrestor Inspect/clean spark plug
Every 300 Hours
Replace spark plug Replace air filter Clean combustion chamber ³ Inspect/adjust valve clearance ³

¹ Replace air filter if it cannot be adequately cleaned.

² Change oil after every 100 hours or yearly, whichever comes first. Service more frequently when operating under heavy load or in high temperatures.

³ Recommend service to be performed by authorized service dealer.

6.2 EMISSION CONTROL SYSTEM

Emission Source

Exhaust gas contains carbon monoxide, nitrogen oxides (NOx) and hydrocarbons. It is very important to control the emissions of NOx and hydrocarbons as they are a major contributor to air pollution. Carbon monoxide is a poisonous gas. The emission of fuel vapors is a source of pollution as well. The generator engine utilizes a precise air-fuel ratio and emission control system to reduce the emissions of carbon monoxide, NOx, hydrocarbons and evaporative fuel emissions.

Regulation

Your engine has been designed to meet current Environmental Protection Agency (EPA) clean air standards. The regulations dictate that the manufacturer provides operation and maintenance standards regarding the emission control systems. Tune up specifications are provided in the Specifications section and a description of the emission control system may be found in the appendix to this manual. Adherence to the following instruction will ensure your engine meets the emission control standards.

Modification

Modification of the emission control system may lead to increased emissions. Modification is defined as the following:

- Disassembling or modifying the function or parts of the intake, fuel or exhaust system.
- Modifying or destroying the speed governing function of the generator.

Engine faults that may affect emission

Any of the following faults must be repaired immediately. Consult with your authorized service centre for diagnosis and repair:

- Hard starting or shut down after starting.
- Unstable idle speed.
- Shut down or backfire after applying an electrical load.
- Backfire or after fire.
- Black smoke and/or excessive fuel consumption.

Replacement parts and accessories

The parts making up the emission control system in your product's engine have been specifically approved and certified by the regulatory agencies. You can trust that the replacement parts supplied by customer service have been manufactured to the same production standard as the original parts. The use of replacement parts or accessories which are not designed for your engine – may negatively affect the engine emission performance. Therefore only use replacement parts and accessories from a qualified service centre to guarantee that the replacement products will not adversely affect emission performance.

Replacement parts other than those from an authorized service centre will void the warranty.

6.3 CHANGING THE OIL

⚠ WARNING!

Used motor oil can cause skin irritations if left in long-term contact with skin. Thoroughly wash off used oil from hands as soon as possible with soap and water.

Do not dispose of used oil in drains or on soil. Local service shops provide environmentally-friendly disposal methods.

Drain the oil rapidly and completely on a level surface while the engine is still warm.

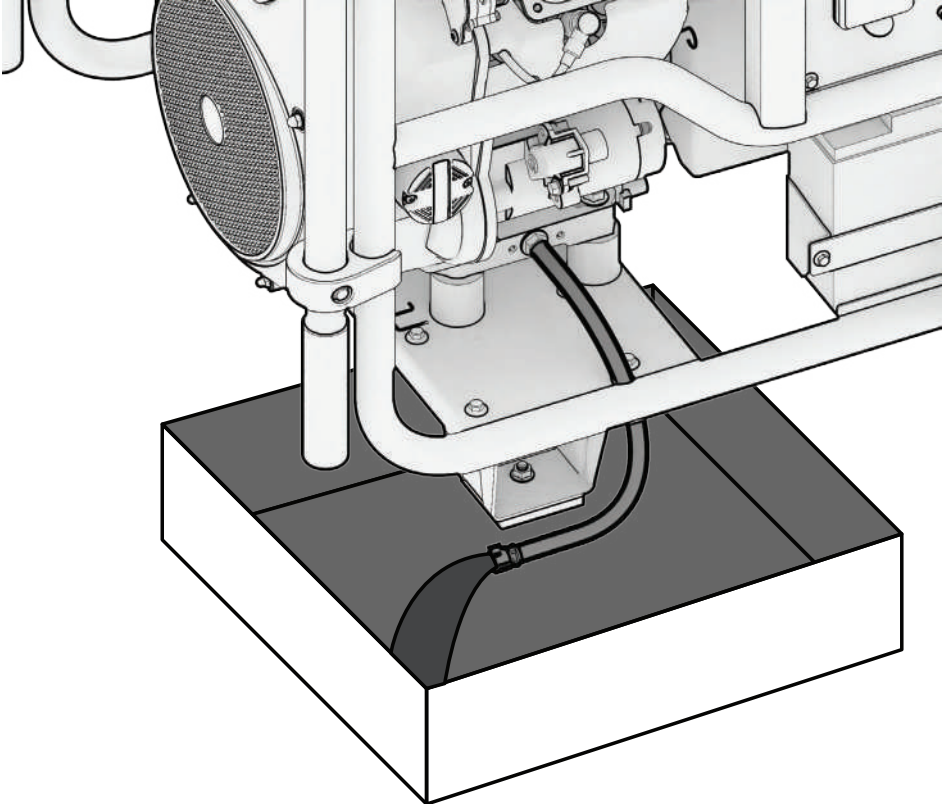

1. Stop the engine and remove oil cap.
2. Place a pan under the engine.
3. Remove the oil drain hose cap and allow the oil to completely drain into the pan.
4. Reinstall oil drain hose cap before filling the engine with fresh oil up to the maximum mark on the dipstick. Do not overfill oil reservoir. Use a funnel to prevent spillage.
5. Reinstall oil cap and tighten.

NOTE

- Oil capacity: 1.5L
- SAE 10W-30 or SAE Synthetic 5W-30 is recommended for general use. Use of synthetic oil does not change maintenance intervals.
- DO NOT OVERFILL.

Effective Viscosity Range of Engine Oils

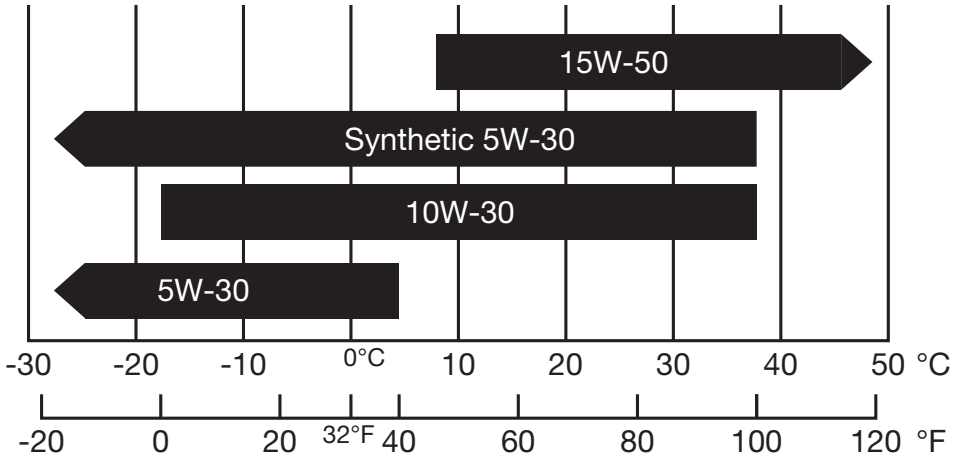
**NOTE**

- Do not tilt the generator when adding engine oil. This could result in overfilling and damage to the engine.
- Use high quality engine oil with strong detergents. Using non-detergent or 2-stroke oil could shorten the engine's working life.
- Handle and store engine oil with care, avoid getting dirt or dust into the oil.
- Do not mix different engine oils.
- Before the engine oil falls below a safe level, the low oil alert system will automatically shut off the engine. The low oil light will turn on.
- To avoid the inconvenience of unexpected engine shutoff, check the engine oil level as often as possible.
- Use 4-stroke engine oil, certified to meet or exceed API standard SG, SF, SAE ratings.

6.4 CLEANING THE AIR-FILTER

⚠ WARNING!

Using gasoline or other flammable solvents can cause a fire or explosion. Do not operate this product without an air filter.

A dirty air filter will restrict air flow into the carburetor. Clean and maintain the air filter regularly, especially in dusty areas.

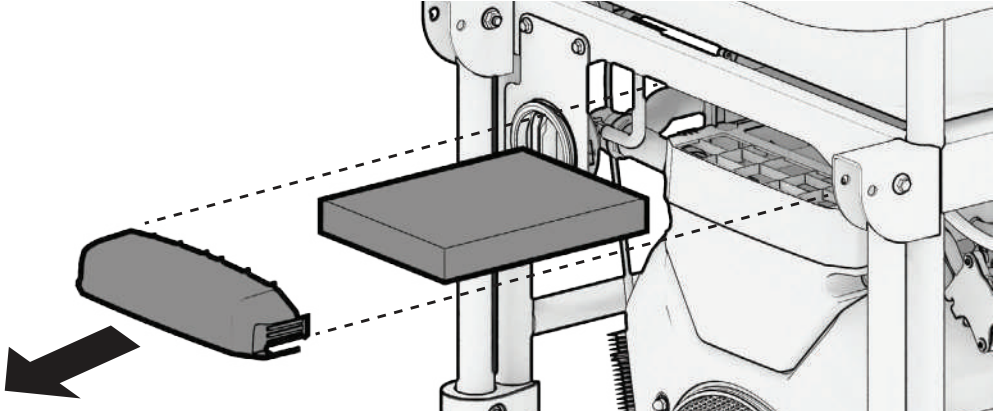

1. Press side tabs and remove the air filter cover. Remove the *foam* air filter element and inspect for cleanliness. Replace the filter if it is damaged.
2. Clean the *foam* air filter with soap and water or solvent and let dry.
3. Re-install air filter and air filter cover.

6.5 SPARK PLUG SERVICE

⚠ WARNING!

Do not rinse spark plug in water. Follow guidelines and be careful not to overtighten the spark plug.

Recommended spark plug:

- **GAS5373**

Check the spark plug gap and clean the carbon deposits at the bottom of the spark plug.

Tighten 1/2 turn when installing a new spark plug.

Tighten 1/8 TO 1/4 turn when re-installing an old spark plug.

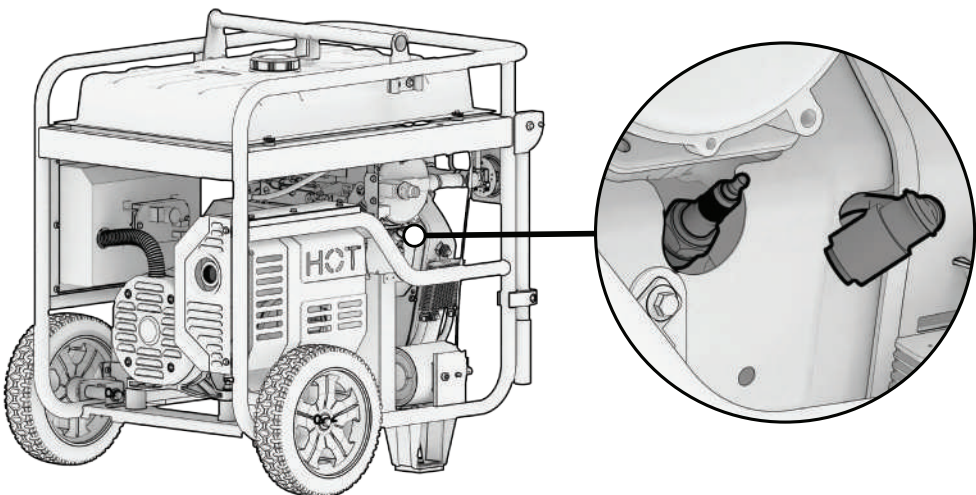
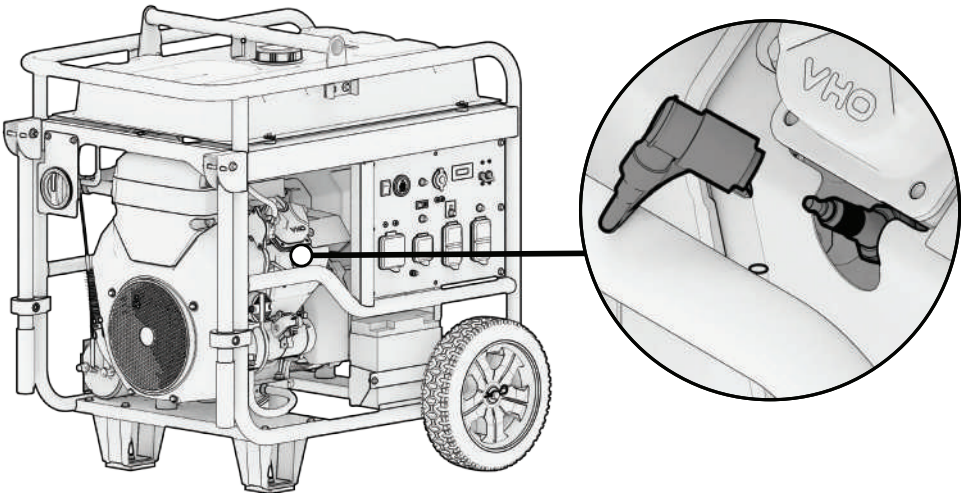

1. Remove the spark plug cap.
2. Remove the spark plug with the spark plug wrench.
3. Visually inspect the spark plug. Replace with a new plug if the insulation is cracked or chipped. Clean with a wire brush if the spark plug is reused.
4. Measure the spark plug gap with a feeler gauge. The normal value is: 0.7-0.8mm (0.028- 0.031in). Adjust the gap by carefully bending the electrode.
5. Carefully reinstall the spark plug by hand, to avoid cross-threading. A new spark plug should be tightened 1/2 turn with a wrench. A used spark plug should be tightened 1/8 to 1/4 turn with a wrench.
6. Reinstall the spark plug cap.

NOTE

- The spark plug must be securely tightened or it could cause the spark plug to heat up, enough to damage the engine.
- Never use a spark plug with an improper heat range.

6.6 SPARK ARRESTER MAINTENANCE

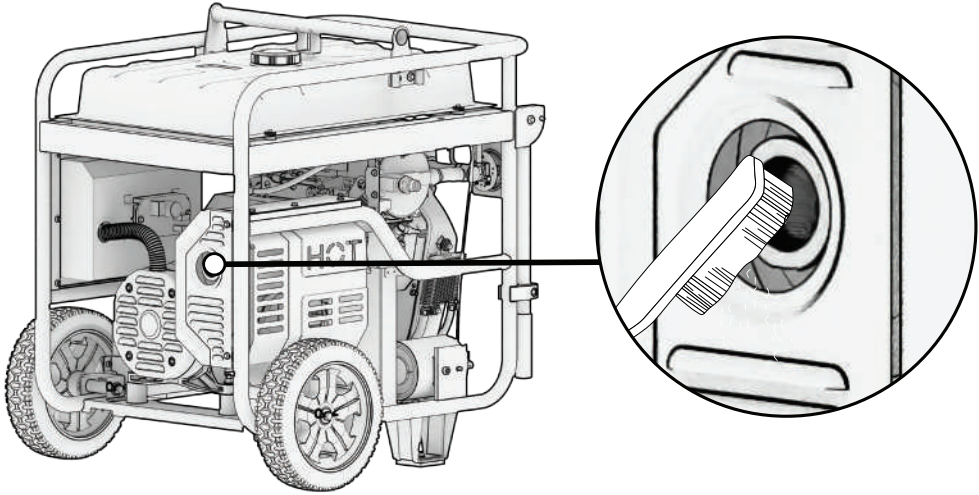

1. Wait for the engine to cool down before cleaning spark arrester.
2. Use a brush to remove carbon deposits from the spark arrester. If the spark arrester is worn down, replace it.
3. Reinstall the spark arrester.

6.7 FUEL FILTER MAINTENANCE

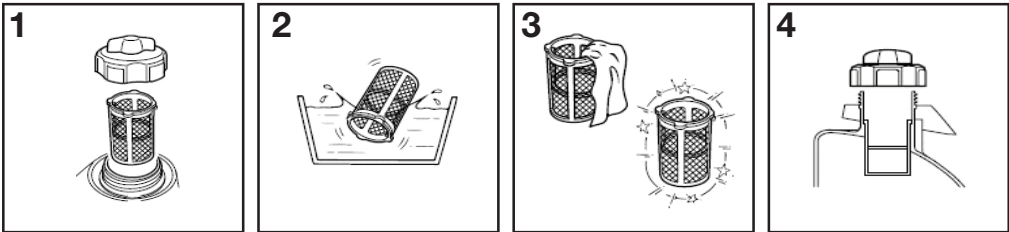

1. Remove the fuel cap and filter.
2. Clean the filter with solvent.
3. Wipe the filter.
4. Reinsert the filter.

6.8 HOW TO SYNC A NEW REMOTE (REMOTE PAIRING)

A new remote can be synced following the steps below.

⚠ DANGER! ⚠

DO NOT perform this procedure indoors it may cause the generator to start. See 'Starting the Engine' for more details.

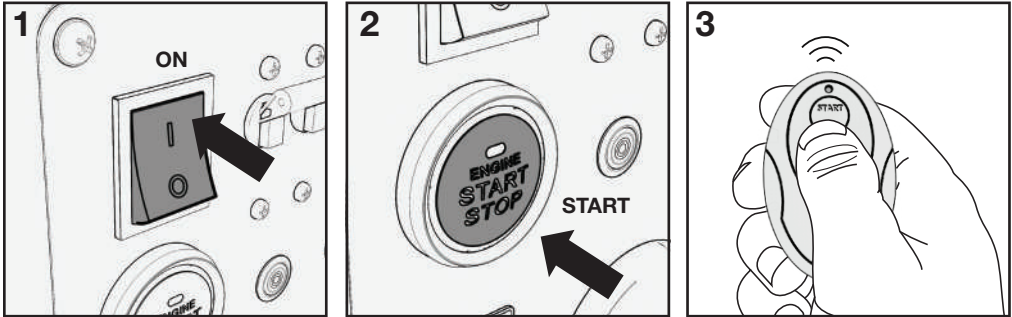

1. Turn the battery power switch to ON.
2. Push and hold the electric start button for 10 seconds then release to initiate remote sync. The Ready to Use light will flash green.
3. Push the START button on the remote. It will begin to pair and once finished the remote start ready light will stop flashing.

6.9 CARBURETOR MODIFICATION FOR HIGH ALTITUDE OPERATION (Above 2000 feet)

- This engine is equipped to run at altitudes below 2,000-ft.
- A high-altitude Main Jet is recommended when operated at 2,000 to 7,000-ft above sea level.
- At elevations above 7,000-ft the engine may experience decreased performance even with a high-altitude Main Jet.

At high altitudes the carburetor's air/fuel mixture becomes too rich, resulting in higher fuel consumption, lower performance, and carbon build-up on the spark plug. On the other hand, if the carburetor has been modified for high altitude operation and is operated below 2000-ft, the air/fuel mixture will then be too lean for low altitude use. Always use the correct Main Jet for your altitude.

The engine's carburetor, governor (if so equipped), and any other parts that control the air/fuel ratio will need to be adjusted by a qualified mechanic to allow efficient high-altitude use, and to prevent damage to the engine and any other devices used with this product. The fuel system on this engine may be influenced by operation at higher altitudes.

- Carburetor bowl may have gas in it which will leak upon removing the bolt.
- The mixing tube is held in place by the Main Jet and might fall out when it is removed. If it falls out, replace it in the same orientation before replacing the Main Jet.
- The Fuel Cup Seal and Bolt Seal may be damaged during removal and should be replaced with the new ones.

1. Turn off the engine.
2. Close the fuel valve.
3. Place a bowl under the fuel cup to catch any spilled fuel.
4. Unthread the bolt holding the fuel cup.
5. Remove the bolt, Bolt Seal, fuel cup, Fuel Cup Seal and Main Jet from the body of the carburetor assembly. A carburetor screwdriver (not included) is needed to remove and install the Main Jet.
6. Replace the Main Jet with the replacement Main Jet needed for your altitude range.
7. Replace the Fuel Cup Seal, fuel cup, Bolt Seal, and bolt. Tighten in place. Do not cross thread bolt when tightening. Finger tighten first and then use a wrench to make sure the bolt is properly threaded.
8. Wipe up any spilled fuel and allow excess to evaporate before starting engine. To prevent FIRE, do not start the engine while the smell of fuel hangs in the air.

7. TRANSPORTATION & STORAGE

Transporting the Generator

- Do not overfill the fuel tank (No residual fuel on the neck of tank).
- Do not use the generator in the vehicle. The generator should ONLY be used while in a well ventilated area.
- Avoid exposing the generator to prolonged direct sunlight while in an enclosed vehicle. The high temperature inside the vehicle could cause fuel to vaporize resulting in a possible explosion.
- Drain the generator of fuel and oil before being transported on rough roads.

Draining the Fuel Tank

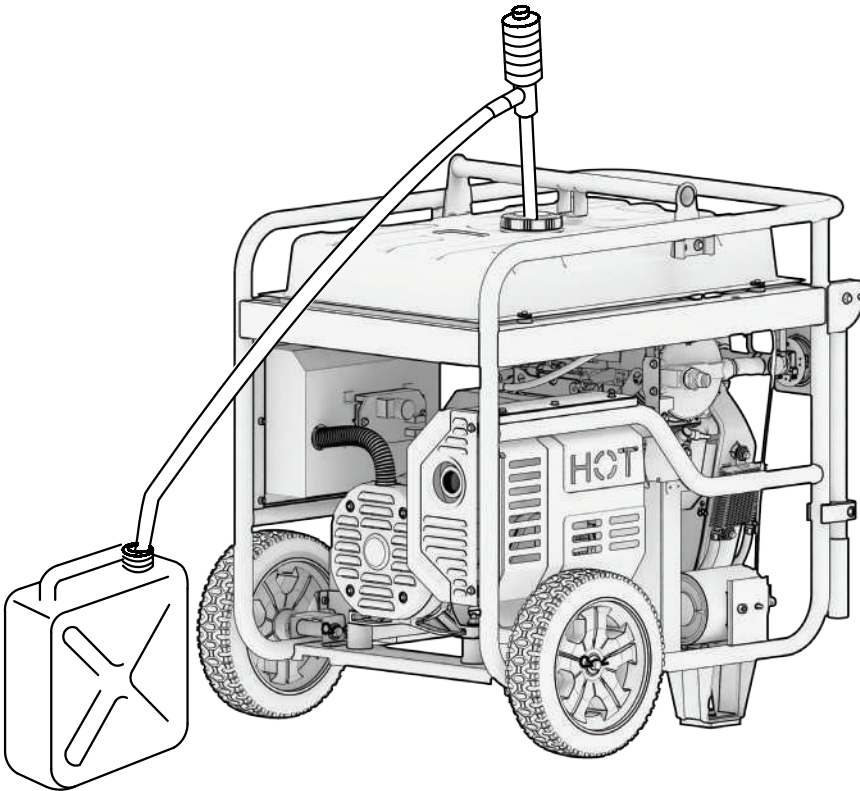

1. Turn OFF the engine. Remove the fuel cap and the debris screen underneath the fuel cap.
2. Empty the fuel tank using a siphon and an approved gasoline container.

Note on Automatic Voltage Regulation (AVR)

Your generator is equipped with an Automatic Voltage Regulator which ensures a constant voltage and presents a waveform similar to what you get from the city power grid. They are an improvement over basic generators but not as effective at safely running sensitive electronics as an inverter generator or the power grid, which produces almost perfect sine waveforms.

Therefore powering sensitive electronics with this generator is not recommended because there is a risk damage will occur to electrical components.

Long Term Storage

Before storing the generator set for an extended period:

- Ensure that the storage area is free of excess humidity and dust.
- Drain the fuel tank and the carburetor.

Storage Duration	Preparation Required
Less than 1 Month	<ul style="list-style-type: none"> ■ No storage preparation required, simply store as is.
1 Month to 1 Year	<ul style="list-style-type: none"> ■ Drain the old gas and completely fill the tank with fresh gas before storage. Add fuel stabilizer according to the manufacturer's directions, we recommend B3C fuel additives. Adding a quality fuel stabilizer can keep gas fresh for up to a year.
1 Year or More	<ul style="list-style-type: none"> ■ Drain off the gasoline from the fuel tank, and store in a suitable container. This will help prevent deposits from forming in the fuel system. ■ Turn the fuel valve to OPEN and loosen the carburetor drain bolt. Take off the spark plug cap and revolve the engine 3 or 4 times, by pulling the recoil handle, to fully discharge the gasoline from the fuel lines. ■ Turn the fuel valve to CLOSED and tighten the drain bolt of the carburetor. ■ Change oil while engine is still warm from operation. ■ Remove the spark plug, and pour a tablespoon of clean engine oil (10~20ml) into the cylinder. Revolve the engine several times by pulling on the recoil start to distribute the oil. Reinstall the spark plug. Pull the starter grip slowly until you feel resistance. At this point, the piston is coming up on its compression stroke and both the intake and exhaust valves are closed. This position helps to protect the engine from internal corrosion.

8. TROUBLESHOOTING

If appliances do not operate:

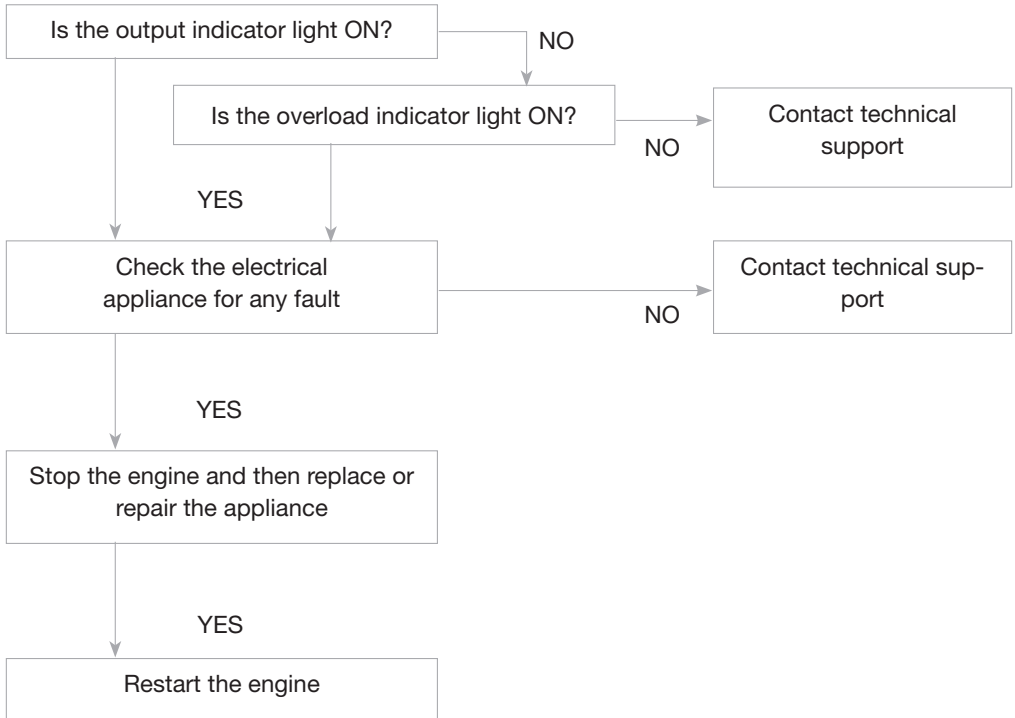

DC receptacle without any electricity:

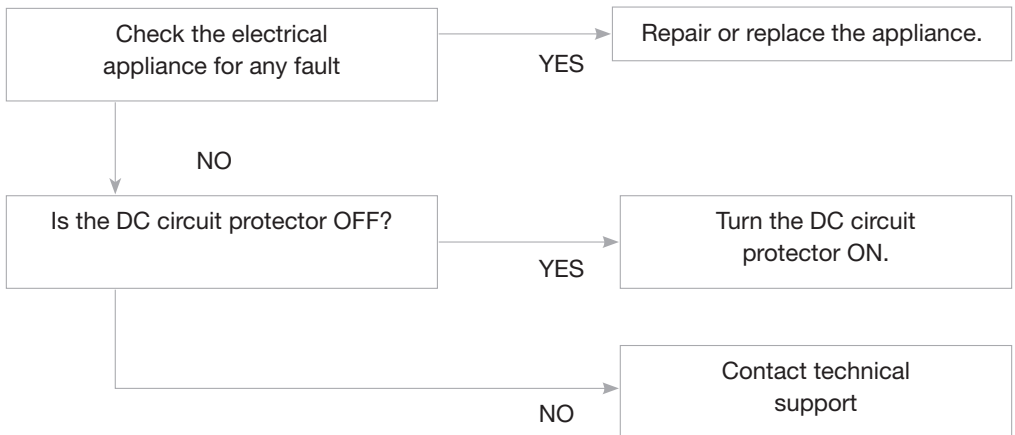

If the engine does not start:

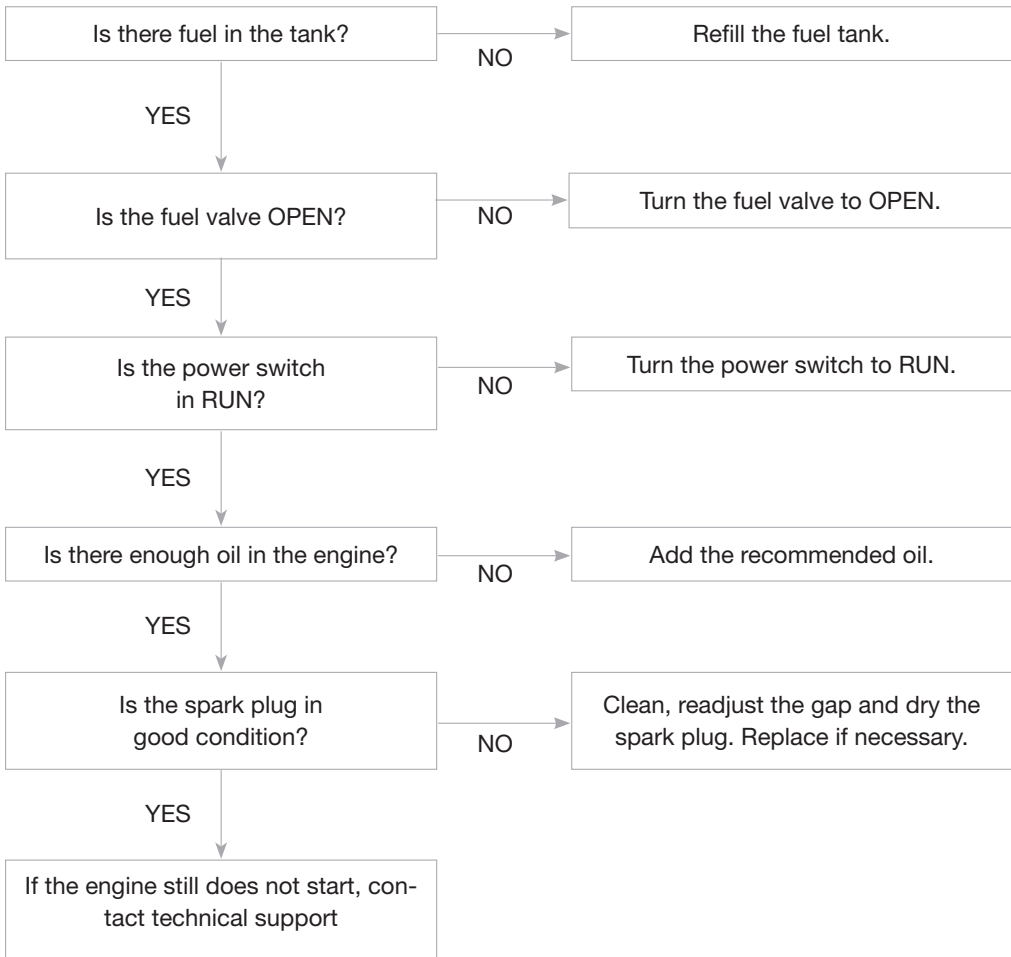

9. TECHNICAL SPECIFICATIONS

		5210-153
GENERATOR	Rated frequency (Hz)	60Hz
	Max Gasoline AC Output Power (W)	15000W
	Running Gasoline AC Output Power (W)	12000W
	Max LPG AC Output Power (W)	13500W
	Running LPG AC Output Power (W)	10800W
	Max NG AC Output Power (W)	10500W
	Running NG AC Output Power (W)	8400W
	AC Voltage (V)	120/240V
Power Factor	1.0	
ENGINE	Type	21.0 HP, Single Cylinder, 4-stroke, OHV
	Displacement (cm ³)	713cc
	Ignition mode	Transistor Controlled Ignition
	Starting mode	Remote Start, Electric Start
	Max. Output (rpm)	3600
	Fuel tank capacity (Gal)	40 L
	Oil capacity	1500 mL (10W30)
	Fuel Type	Unleaded gasoline 87+ Octane
UNIT	L x W x H	34.3 x 30.3 x 34.9"
	Weight	347.6 lbs
BAT.	Battery Size	12V 18Ah

11. APPENDIX

The standard condition of rated power output:

Altitude: 0m

Ambient temperature: 25°C

Relative humidity: 30%

Factor of Environment Correction:

Altitude (m)	Ambient Temperature°C				
	25	30	35	40	45
0	1	0.98	0.96	0.93	0.90
500	0.93	0.91	0.89	0.87	0.84
1000	0.87	0.85	0.82	0.80	0.78
2000	0.75	0.73	0.71	0.69	0.66
3000	0.64	0.62	0.60	0.58	0.56
4000	0.54	0.52	0.50	0.48	0.46

NOTE:

Relative humidity 60% correction factor C-0.01

Relative humidity 80% correction factor C -0.02

Relative humidity 90% correction factor C-0.03

Relative humidity 100% correction factor C-0.04

Example:

Rated power (PN) 2.8kVA generator (Altitude: 1000m) Ambient temperature: 35°C,

Relative humidity: 80%

$$P=P_n*(C-0.02)=2.8*(0.82-0.02)=2.24kVA$$

13. LIMITED WARRANTY

This product is distributed by:

Midland Power Inc.

376 Magnetic Drive, Toronto, ON M3J 2C4, Canada

Warranty

Beginning at the time of retail purchase and for the duration of the warranty period Midland Power Inc. (Midland) warrants that Equipment manufactured by it is warranted to be free from defects in material and workmanship. Midland will, at its sole discretion, replace or repair any part(s) which, upon evaluation and testing by Midland or an authorized service center, show a defect in workmanship or material. Valid proof of purchase must be submitted online for registration with Midland, or presented to Midland at time of claim, for warranty to be valid. This warranty is not transferable from the original owner.

Limited Warranty Period:

Non-commercial use:

- Year 1, 2 and 3 - Parts and Labour
- Year 4 and 5 - Parts

Commercial use:

- First 6 Months - Parts and Labour

Commercial use includes utilization of the purchased product for a business or non-profit organization, or to financially benefit an individual. This includes, but is not limited to, usage in the context of a financial transaction, usage on commercial or non-profit property, or usage for advertising or marketing purposes.

Replacement parts sold to a consumer or installed by an authorized service center are warranted for a period of 90 days from date of purchase. Labour must be performed by an authorized service center unless given Midland's prior written approval. Midland will not bear any transportation or shipping fees to or from an authorized service center. Service calls, travel charges, overtime, or weekend rates, are not covered.

This warranty does NOT cover:

- a. Any repairs required as a result of any parts not supplied by Midland, and this part is responsible for the failure or malfunction;
- b. Any Equipment modified, altered, disassembled or remodelled;
- c. Any repairs required as a result of a failure to install, maintain, store, transport, or operate the Equipment in accordance with standard practices set out in the user guide;

- d. Damage that occurred after receipt of equipment, not caused by defects in workmanship or material;
- e. Normal maintenance services, as outlined in the user guide and intended for a consumer to perform;
- f. Replacement of parts made in connection with normal maintenance services including oils, adhesives, additives, fuel, filters, brushes, belts, lubricants, spark plugs, gaskets, seals, fasteners, wires, tubes, pipes, fittings, wheels, batteries, and other expendables susceptible to natural wear;
- g. Any accessory or attachment.

Any battery supplied with this Equipment is considered a consumable item and is excluded from this warranty. Batteries can be damaged by shock, shorting terminals, heat, acid spillage, neglect, and other factors. It is the customer's responsibility to take great care when handling a battery so no spillage of acid occurs which may cause corrosion.

Midland disclaims any responsibility for loss of time or use of the product, transportation, or towing costs or any other indirect, incidental, or consequential damage, inconvenience or commercial loss.

This warranty is the entire and only warranty given by Midland for Midland products or equipment. No agent or employee is authorized to extend or enlarge this warranty on behalf of Midland by any written or verbal statement or advertisement.

California

The California Air Resources Board and Midland Power Inc. are pleased to explain the emission control system warranty on your Midland Power Inc. engine. In California, new spark-ignited small off-road equipment engines must be designed, built, and equipped to meet the State's stringent anti-smog standards.

Other States, U.S. territories, and Canada

In other areas of the United States and in Canada, your engine must be designed, built, and equipped to meet the U.S. EPA and Environment Canada emission standards for spark-ignited engines at or below 19 kilowatts.

All of the United States and Canada

Midland Power Inc. must warrant the emission control system on your power equipment engine for the period of time listed below, provided there has been no abuse, neglect, or improper maintenance of your power equipment engine. Where a warrantable condition exists, Midland Power Inc. will repair your power equipment engine at no cost to you including diagnosis, parts, and labor.

Your emission control system may include such parts as the carburetor or fuel injection system, the ignition system, and catalytic converter. Also included may be hoses, connectors, and other emission-related assemblies.

Emission Control System Warranty Parts:

This list applies to parts supplied by Midland Power Inc. and does not cover parts supplied by the equipment manufacturer. Please see the original equipment manufacturer’s emissions warranty for non-Midland Power Inc. parts.

Consumable parts are covered up to a maximum of 30 days.

SYSTEMS COVERED IN WARRANTY	PARTS DESCRIPTION
Fuel Metering	Carburetor assembly (includes starting enrichment system), Engine temperature sensor, Engine control module, Fuel regulator, Intake manifold
Evaporative	Fuel Tank, Fuel Cap, Fuel Hoses, Vapor Hoses, Carbon Canister, Canister Mounting Brackets, Fuel Strainer, Fuel cock, Fuel Pump, Fuel Hose Joint, Canister Purge Hose Joint
Exhaust	Catalyst, Exhaust Manifold
Air Induction	Air filter housing, Air filter element
Ignition	Flywheel magneto, Ignition pulse generator, Crankshaft position sensor, Power coil, Ignition coil assembly, Ignition control module, Spark plug cap, Spark plug
Crankcase Emission Control	Crankcase breather tube, Oil filler cap
Miscellaneous Parts	Tubing, fittings, seals, gaskets, and clamps associated with these listed systems



Customer Service

Online: www.benchmark.midlandpowerinc.com

E-mail: support@midlandpowerinc.com

Toll Free: 1-877-528-3772

Enjoy!

Be sure to check www.benchmark.midlandpowerinc.com for updates regarding your product.





BENCHMARKTM_{MC}

5210-153