

BENCHMARK™

THROUGH-WALL KIT

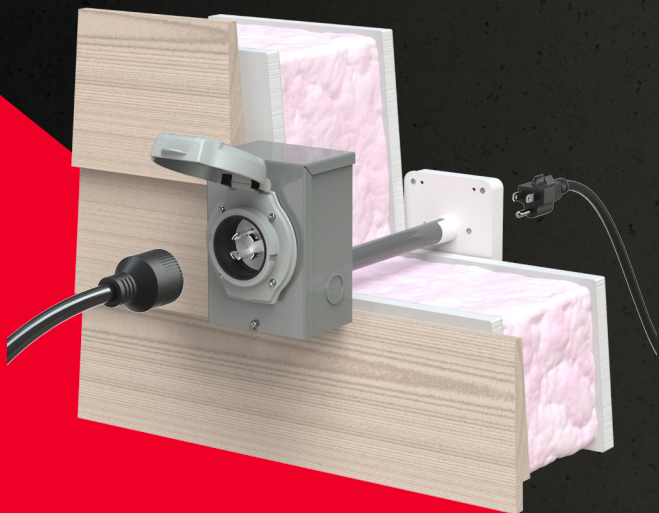

USER MANUAL



This product is supported by **Midland Power**.
Contact us directly for assistance and warranty help.
Do not return this product to store.

You must register online for your warranty to be valid.
It only takes a minute, do it now while you still have
your purchase receipt.

Register Your Product Online

[www.benchmark.midlandpowerinc.com/
register-warranty](http://www.benchmark.midlandpowerinc.com/register-warranty)



Support for your product is available online, including
parts, service center locations, and live expert advice.

Visit us online at

www.benchmark.midlandpowerinc.com



Or call us anytime at **1-877-528-3772**.

Thanks for choosing the Benchmark Wall Kit!

You're excited to get started, we'll keep this brief.

READ THIS ENTIRE GUIDE BEFORE USING THIS PRODUCT AND SAVE FOR LATER USE.

This user guide contains important instructions including safety, setup, operation, and maintenance that must be followed. All information in this guide is based on information available at the time of print. This guide or revised editions can be found on our website for download. No part of this publication may be reproduced without written permission.

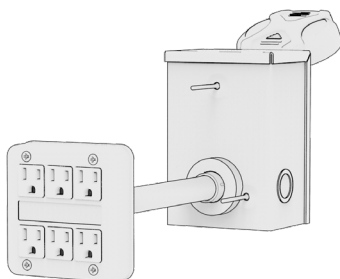

THIS PRODUCT MEETS ALL CERTIFICATION REQUIREMENTS FROM:





©2022 Home Hardware Stores Limited. All Rights Reserved.

BENCHMARK_WALLKIT_UG_EN_2022-02-08

TABLE OF CONTENTS

1. Safety	1
1.1 Operator Safety	2
2. Learn More About Your Wall Kit	3
2.1 Component Identification	3
2.2 Make Sure You Have Everything	4
3. Installation	6
STEP 1 - Plan Your Installation	6
STEP 2 - Make a Hole in Your Wall	8
STEP 3 - Prepare to Mount the Power Panel	11
STEP 4 - Cement the Conduit to the Power Panel	13
STEP 5 - Mount the Inside Power Panel	14
STEP 6 - Attach the Conduit Fitting to the Outdoor Inlet Box	15
STEP 7 - Try a Dry Fitting	16
STEP 8 - Mount the Outdoor Inlet Box	17
STEP 9 - Wire the Inlet Box	19
4. Operation	21
5. Technical Specifications	24
6. Limited Warranty	25

1. SAFETY

⚠ DANGER	
<p>Using a generator indoors CAN KILL YOU IN MINUTES. Generator exhaust contains carbon monoxide. This is a poison you cannot see or smell.</p>	
	
<p>NEVER use inside a home or garage, EVEN IF doors and windows are open.</p>	<p>Only use OUTSIDE and far away from windows, doors, and vents.</p>
<p>Avoid other generator hazards. READ MANUAL BEFORE USE.</p>	

⚠ DANGER! ⚠

This kit naturally pairs with a generator. Be aware of all hazards involved and make sure to read the entire user guide included with your generator. Generator exhaust contains carbon monoxide. This is a poison you cannot see or smell. NEVER use a generator inside a home or garage, EVEN IF doors and windows are open. Only use OUTSIDE and far away from windows, doors, and vents. ALWAYS keep your generator outside and away from open windows and doors.

⚠ WARNING!

Midland Power Inc. is not responsible for any damage caused during installation. Installation of this kit and alteration of your property is undertaken at your own risk.

Midland Power Inc. is not responsible for health issues resulting from contact or ingestion with the supplied PVC cement. Fully read safety precautions on label of PVC cement.

1.1 OPERATOR SAFETY

WARNING!

- DO NOT connect outdoor inlet box to live power prior to installation. Doing so could result in electrical failure, fire, and electrocution.
- DO NOT connect this kit to any power source other than a portable generator.
- DO NOT connect this kit to your home electrical wiring. It is only to be used as a standalone circuit.
- DO NOT use this kit with multi-outlet extension cords or outlet splitters.
- DO NOT use more than one device per 15A outlet on this kit.
- ALWAYS use extension cords rated for the amperage required by the device being powered.

2. LEARN MORE ABOUT YOUR WALL KIT

This section will show you how to identify key parts of your wall kit. Going over the terminology below will make sure we're on the same page.

2.1 COMPONENT IDENTIFICATION

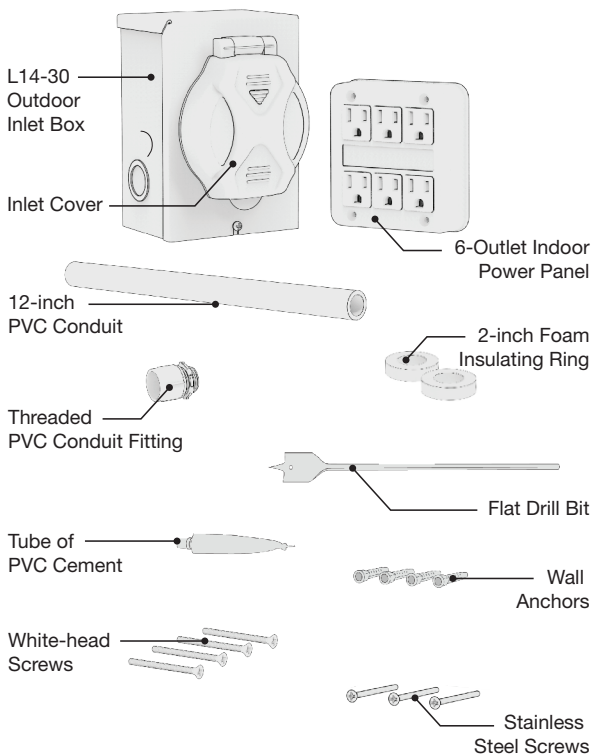

2.2 MAKE SURE YOU HAVE EVERYTHING

With this kit you can now power your devices during a power outage without exposing your household to dangerous carbon monoxide (CO) gas.

Make sure this kit is complete and included the following:

Part Name	Quantity
6-Outlet indoor power panel	1
L14-30 Outdoor inlet box	1
12-inch Flat drill bit (non-masonry)	1
12-inch PVC conduit	1
Threaded PVC conduit fitting	1
Tube of PVC cement	1
2-inch foam insulating rings	2
White-head 1 7/8-inch indoor power panel mounting screws	4
Wall anchors	4
Stainless steel 1 1/8-inch outdoor inlet box mounting screws	3
User Guide	1

You will need these extra tools during installation:

Tools	Quantity
Power drill	1
Phillips screwdriver	1
¼-inch drill bit	1
Pliers	1
Measuring tape	1
Pen or pencil	1
PVC cutter or hacksaw	1
Knockout Punch Set	1
Snacks	1

To operate this kit you will need:

- Generator with a running wattage of at least 7,500W with a 125/250V 30A L14-30 outlet. The outlet must be grounded and include a breaker of 30A or less. This kit can only provide as much power as your generator supplies, if your generator supplies less than 7,500W this kit will be underpowered but can still function normally. If your generator can only produce 125V then only half the outlets on this kit will provide power.
- L14-30 Power cord rated for outdoor use. Must be capable of 125/250V at 30A, have four 10-gauge wires, and come equipped with one male and one female L14-30 head.

3. INSTALLATION

⚠ WARNING!

There are many steps to follow in this guide, if you miss or proceed too quickly past one you may ruin your instal. We recommend you read through this entire manual and understand the process before proceeding step-by-step.

STEP 1 - PLAN YOUR INSTALLATION

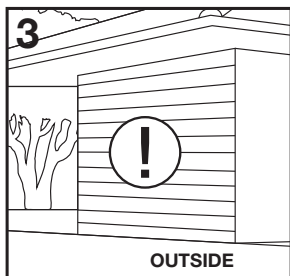
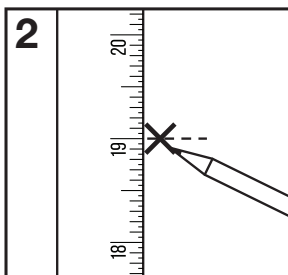
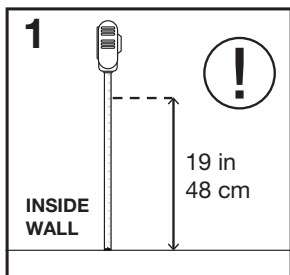

1. Before starting, we recommended checking with your local building inspector to see if a permit is

required for this installation. Be sure to point out that this kit will NOT be connected to your home electrical wiring.

2. Inside, find a convenient place for the power panel a recommended 19 inches (48cm) from the floor. The location should be between wall studs so the conduit will pass freely through your wall, not in line with an electrical outlet, and not in alignment with known water, waste, or other pipes. Think about the devices you want to power with this kit and if they can be used in this area. Once you have determined a location, mark the spot with a pencil. This mark will be the center of the power panel.
3. Outside, estimate the spot on your exterior wall directly opposite the location of the indoor power panel. Make sure it is flat, vertical, and clear of objects such as bushes, utilities, cable TV boxes, or other. Make sure that the area surrounding the exterior wall is clear of obstructions so the power cord from your generator can protrude out and down from the inlet box. You need easy access to this area day and night, during all weather, and when the power is out. Your generator needs a clear area it can be placed at least 10-ft away, downhill from your house, where it can be reached by your power cord.

NOTE

- If you do not have a suitable location to install the outdoor inlet box opposite the indoor power panel you may choose to install the inlet box in a remote location. It is possible to connect the indoor power panel to the outdoor inlet box using grounded building wire up to 100-ft

in length. You will need to install a recessed junction box in the wall behind the power panel to safely extend the wiring. You must consult a professional electrician to complete this alternate instal according to local building codes.

STEP 2 - MAKE A HOLE IN YOUR WALL

NOTE

- The 12-inch flat drill bit supplied with this kit is designed to drill through drywall, wood paneling, plywood, wood studs, insulation panels, wood, vinyl, aluminum, plank, and all other non-masonry materials. If you need to drill through masonry materials such as brick, concrete block, or poured cement, we recommend you purchase a 1 ¼-inch (32mm) masonry drill bit or other drill bit suited for the type of wall you have. Other adjustments in the hole-boring process may be needed in drilling through other wall types, including lathe and plaster. Otherwise, follow all installation steps as outlined below.

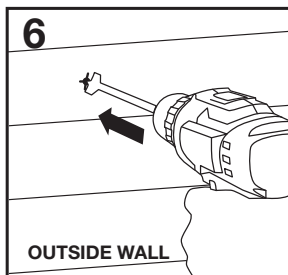
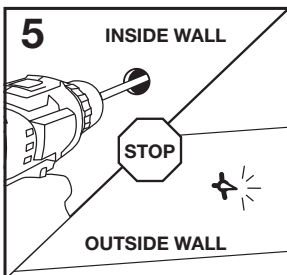
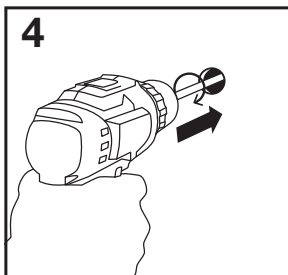
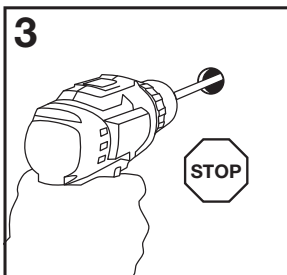
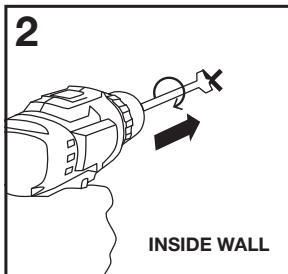
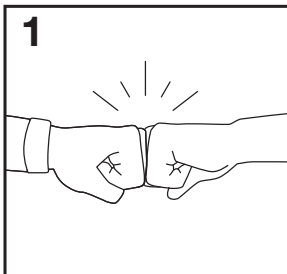

1. If any friends or relatives are nearby they will be helpful to have on hand for this installation, but may require snacks.
2. On the inside wall, center the pointed tip of the 12-inch flat drill bit on your pencil mark, level the drill parallel to the floor. Slowly and steadily apply firm

pressure as you drill through only your first layer of drywall or paneling, stop before drilling further.

3. With your drill bit now past the first layer of wall, with the drill off, probe the interior of the wall for any electrical, water, or waste pipes that could be in your direct path through the wall. If you find any obstruction you must try again in another location. If your way is clear, pull the drill bit back toward the interior wall and level the drill again.
4. Continue drilling. If the drill contacts any insulation move the drill forward slowly at high RPM to make sure the bit has a chance to cut through the insulation gradually without snagging. Forcing the drill bit through the insulation quickly may cause it to snag.
5. Once the drill bit contacts the outside wall, apply steady pressure until just the tip of the bit breaks through. Ask your helper to watch the outside wall and signal when the tip of the bit emerges. Stop the drill and slowly back the drill bit completely out of the inside wall.
6. Move to the outside of the house, center the pointed tip of the drill in the hole that was created. Keeping your drill level and on high RPM, carefully and slowly drill through the wall, varying the drill speed as needed to avoid cosmetic damage until you have a clean hole.

STEP 3 - PREPARE TO MOUNT THE POWER PANEL

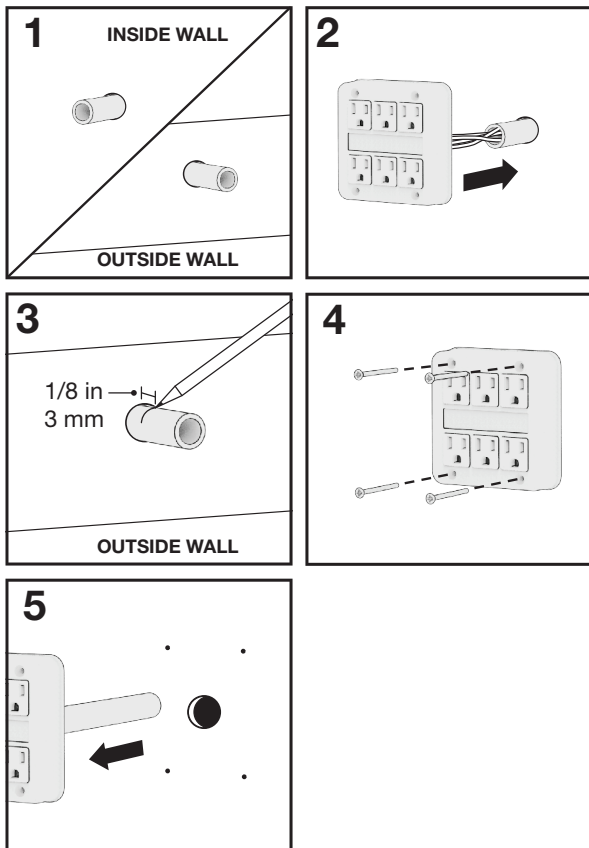

1. From inside your house, slowly push the 12-inch PVC conduit through the hole until it contacts the exterior wall. Gently probe with the conduit

until you find the exterior hole, then push conduit through. The PVC conduit should be protruding a few inches out from each side of the wall.

2. Straighten the wires attached to the back of the 6-outlet indoor panel. Push all wires through the conduit, then push the rear protrusion on the back of the power panel firmly over the conduit.
3. Hold the power panel tightly against the inside wall with its rear protrusion inside the hole you made. Outside, have someone mark the conduit visibly with pen or pencil 1/8-inch (3mm) away from the surface of the outside wall.
4. Inside, make sure the panel is level and parallel to your floor, as you would like it to be permanently mounted. Insert the four white-head 1 7/8-inch (4.9 cm) mounting screws into each of the four mounting holes on the power panel and push them with your hand or screwdriver into your wall just enough to leave a clear mark.
5. Pull the power panel and conduit out of the wall. Fully separate the conduit from the power panel and attached wires.

STEP 4 - CEMENT THE CONDUIT TO THE POWER PANEL

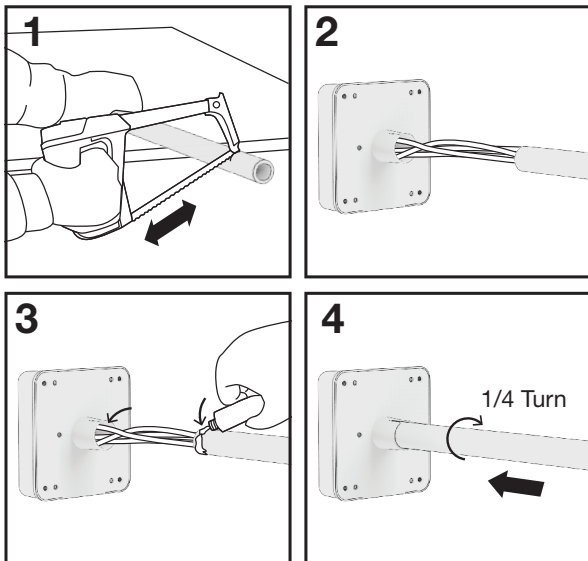

1. Use a hacksaw or PVC cutter to cut the PVC conduit at the pencil or pen mark.
2. Reinsert wires of the power panel halfway through the conduit. Do not insert conduit into the power panel yet.
3. Apply a thin coat of PVC cement all the way around the conduit on the end closest to the power panel, as well as inside the rear protrusion of the power panel where the conduit will sit.
4. Push conduit into power panel rear protrusion, twist a quarter turn, and hold firmly for 10 seconds until bonded.

STEP 5 - MOUNT THE INSIDE POWER PANEL

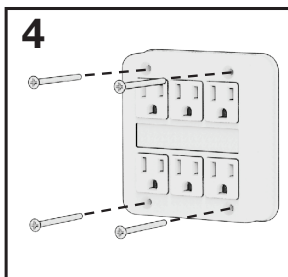
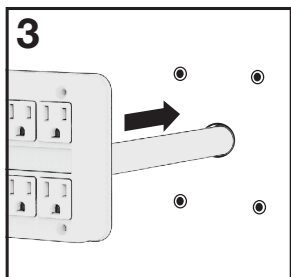
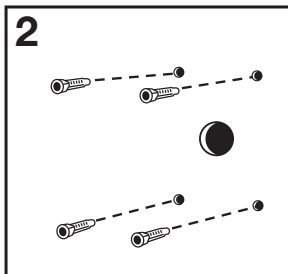
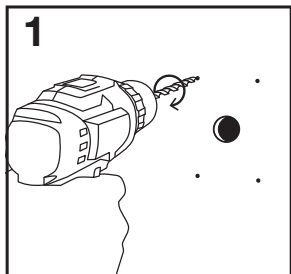

1. Drill a 1/4-inch hole at each of the 4 marks on your wall, deep enough for each wall anchor to be fully inserted.
2. Insert one wall anchor into each hole and tap in lightly until flush with your wall.
3. Carefully push the power panel now bonded with the conduit back through the hole in your wall and position so the four holes in the power panel align with the four wall anchors.
4. Insert the 4 white head screws through the power panel and screw into the wall anchors with screwdriver until snug against the wall, do not overtighten.

STEP 6 - ATTACH THE CONDUIT FITTING TO THE OUTDOOR INLET BOX

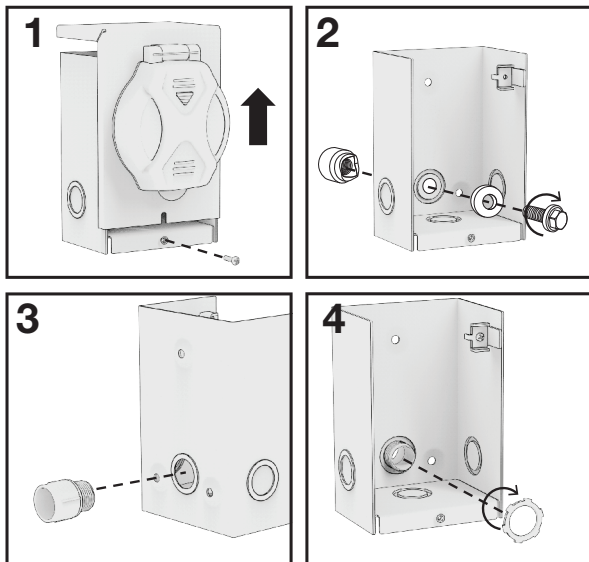

1. Remove the screw below the plastic inlet port on the metal outdoor inlet box and lift the metal faceplate up and out. Place the base of the inlet box face down on a solid surface so that the back of the box with three mounting holes is facing upwards.
2. Locate the circular knockout hole on the back of the inlet box, remove the knockout using a knockout punch set or a drill.
3. Unscrew the tightening ring from the PVC conduit fitting, leaving the insulating ring on the fitting.
4. From the back of the inlet box push the threaded

end of the conduit fitting through the knockout hole. Screw the tightening ring onto the conduit fitting from the inside of the power inlet box and tighten using pliers.

STEP 7 - TRY A DRY FITTING

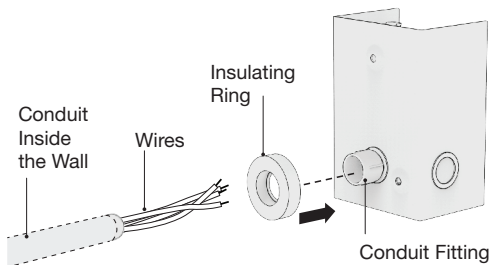

1. Thread the wires through the conduit fitting into the inlet box. Push conduit fitting over the conduit recessed in the hole in your wall.
2. The metal inlet box should be flush to the outside wall. Depending on how tight the inlet box is to your wall, fit one or two foam weather insulating rings over the conduit fitting on the back of the inlet box. When the inlet box is pressed up against the outside wall, the foam insulating ring(s) should compress to form a tight seal.
3. If satisfied, remove inlet box from wall and unthread wires.

STEP 8 - MOUNT THE OUTDOOR INLET BOX

NOTE

- Since outside wall contours and materials vary widely it will be up to you to determine whether you need different screws or anchors for the three supplied screws.

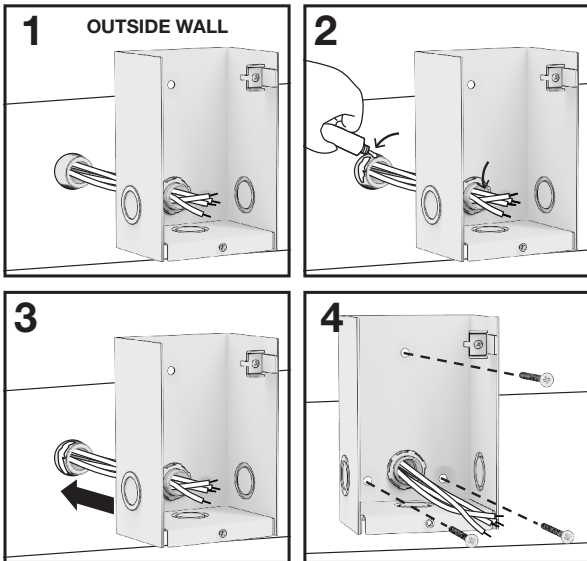

1. Fish wires through the conduit fitting and into the inlet box. Do not push conduit fitting over the conduit yet.
2. Apply a thin coat of PVC cement all the way around conduit in the wall as well as to the inside of the conduit fitting where the conduit will sit.

3. Making sure to hold the inlet box level and in its final position, push the conduit fitting over the conduit and hold firmly for 10 seconds until bonded.
4. Insert the three 1 1/8-inch (3cm) mounting screws into the three mounting holes on the back of the inlet box and screw into exterior wall with power drill, being careful not to distort soft exterior wall materials, do not overtighten. Make sure the foam insulating ring(s) around the conduit fitting were compressed when tightening to ensure weatherproofing.

STEP 9 - WIRE THE INLET BOX

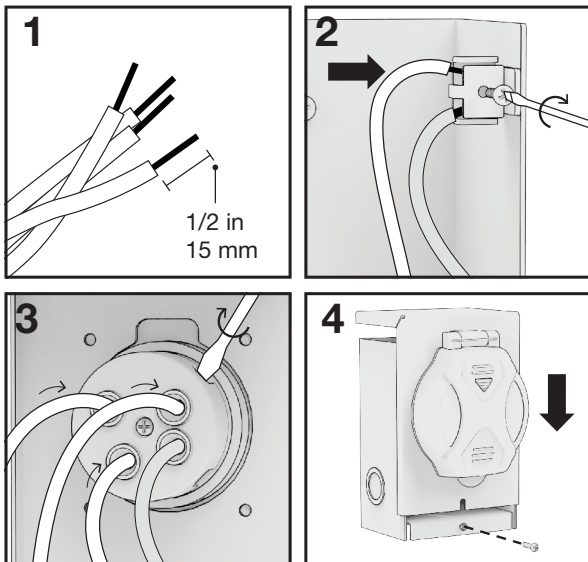

1. Strip all 4 wires so that 1/2-inch (15mm) of copper wire is exposed.
2. Loosen ground screw inside the base of the metal inlet box that came pre-wired with a green grounding wire. Insert the green wire from power panel in the same location as the pre-wired green grounding wire and tighten the grounding screw. Make sure the pre-wired green grounding wire remains connected to the inlet, faceplate, and base of the metal inlet box.
3. Insert the remaining three wires into the holes in the back of the inlet port. Push the wires all the way into the holes and tighten the set screws on

the sides of each terminal until the wire will not pull out. Make sure the copper wire, not the insulation, is clamped in the terminals.

- White wire into white hole marked “W”
 - Red wire into red hole marked “X”
 - Black wire into clear or black hole marked “Y”
4. Tuck the wires neatly into the inlet box. Replace the faceplate over the base, tightening the screw below the plastic inlet port.

The Installation is finished, congrats! Eat your remaining snacks.

4. OPERATION

OUTDOOR INLET BOX

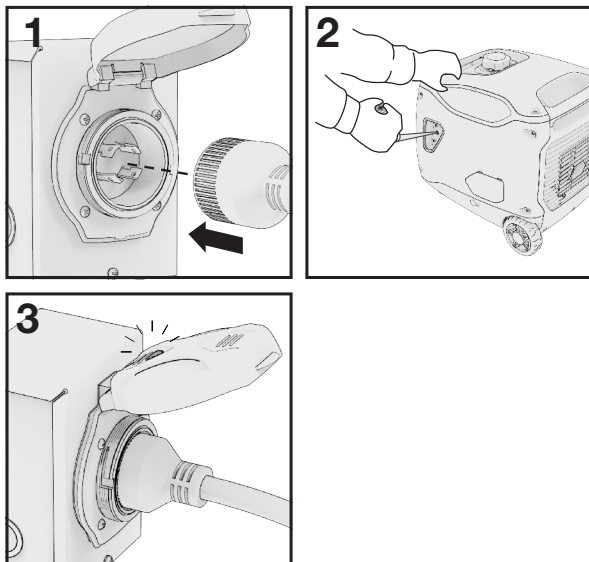

1. Using a 30A L14-30 power cord rated for outdoor use:
 - Open the inlet cover and insert the female end of the cord.
 - Match the shapes of the female head with the prongs of the power inlet, push the cord in firmly.
 - Twist the connector clockwise until it locks in place.

2. Start your portable generator following instructions that came with your generator.
3. Your indoor power panel should now be live, a green light will illuminate on the inlet cover of the inlet box.

INDOOR POWER PANEL

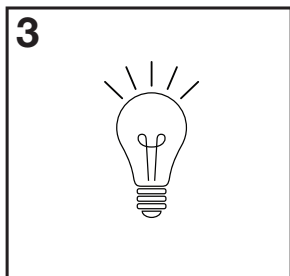
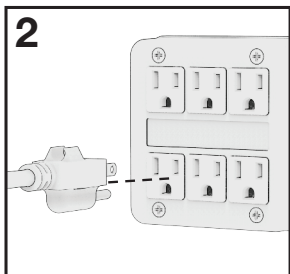
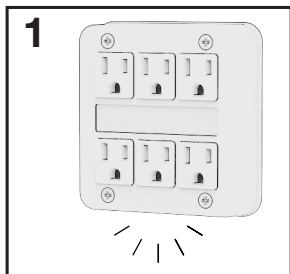

1. When all six receptacles on your power panel are live under generator power, the down-facing floodlight LEDs will be ON. If only 120V is being received, half the LED lights will be ON. In a dark room with the lights off, these lights will enable you to find the power panel during a blackout.
2. Only plug in one appliance per receptacle. Do not

use multi-outlet extension cords to plug in additional items. Make sure that extension cords are rated for the total amps used by the item connected to them.

- 3.** Alternate plugging in your heaviest appliance loads between the top three outlets and the bottom three outlets. The heaviest appliance loads are devices like your refrigerator, freezer, window air conditioner, sump pump, hair dryer, coffee maker, toaster, or microwave. The lightest appliance loads would be things like your smart phone, computer, lights, TV, furnace blower, or electric fan.

5. TECHNICAL SPECIFICATIONS

	SPECIFICATIONS	PARAMETERS
WALL KIT	Max Power	7,500W
	Amperage (A)	30A
	Minimum Wall Thickness	2 in
	Maximum Wall Thickness	12 in
	Input Port	125/250V 30A L14-30P
	Outlet Port	6x 125V 15A 5-15R
	Interior Power Panel Dimensions (L*W*H)	4 x 1.9 x 4.1 in
	Outdoor Inlet Box Dimensions (L*W*H)	4.2 x 4.1 x 6.1 in
	Net Weight	4.4 lbs / 2 kg

6. LIMITED WARRANTY

This product is distributed by:

Midland Power Inc.

376 Magnetic Drive, Toronto, ON M3J 2C4, Canada

Warranty

Beginning at the time of retail purchase and for the duration of the warranty period Midland Power Inc. (Midland) warrants that Equipment manufactured by it is warranted to be free from defects in material and workmanship. Midland will, at its sole discretion, replace or repair any part(s) which, upon evaluation and testing by Midland or an authorized service center, show a defect in workmanship or material. Valid proof of purchase must be submitted online for registration with Midland, or presented to Midland at time of claim, for warranty to be valid. This warranty is not transferable from the original owner.

Limited Warranty Period:

Non-commercial use:

- Year 1 - Parts and Labour
- Year 2 - Parts
- Year 3 - Parts

Commercial use:

- First 6 Months - Parts and Labour

Replacement parts sold to a consumer or installed by an authorized service center are warranted for a period of 90 days from date of purchase. Labour must be performed by an authorized service center unless given Midland's prior written approval. Midland will not bear any

transportation or shipping fees to or from an authorized service center. Service calls, travel charges, overtime, or weekend rates, are not covered.

This warranty does NOT cover:

- a. Any repairs required as a result of any parts not supplied by Midland, and this part is responsible for the failure or malfunction;
- b. Any Equipment modified, altered, disassembled or remodelled;
- c. Any repairs required as a result of a failure to install, maintain, store, transport, or operate the Equipment in accordance with standard practices set out in the user guide;
- d. Damage that occurred after receipt of equipment, not caused by defects in workmanship or material;
- e. Normal maintenance services, as outlined in the user guide and intended for a consumer to perform;
- f. Replacement of parts made in connection with normal maintenance services including oils, adhesives, additives, fuel, filters, brushes, belts, lubricants, spark plugs, gaskets, seals, fasteners, wires, tubes, pipes, fittings, wheels, batteries, and other expendables susceptible to natural wear;
- g. Any accessory or attachment.

Any battery supplied with this Equipment is considered a consumable item and is excluded from this warranty. Batteries can be damaged by shock, shorting terminals, heat, acid spillage, neglect, and other factors. It is the customer's responsibility to take great care when handling a battery so no spillage of acid occurs which may cause corrosion.

Midland disclaims any responsibility for loss of time or use of the product, transportation, or towing costs or any other indirect, incidental, or consequential damage, inconvenience or commercial loss.

This warranty is the entire and only warranty given by Midland for Midland products or equipment. No agent or employee is authorized to extend or enlarge this warranty on behalf of Midland by any written or verbal statement or advertisement.

Enjoy!

Be sure to check www.benchmark.midlandpowerinc.com
for updates regarding your wall kit.





Customer Service

Online: www.benchmark.midlandpowerinc.com

E-mail: support@midlandpowerinc.com

Toll Free: 1-877-528-3772



BENCHMARKTM
THROUGH-WALL KIT