

# BENCHMARK<sup>TM</sup><sub>MC</sub>

## 10 CU FT WHEELBARROW

Item # 5160-267



2 year limited warranty

**READ ALL INSTRUCTIONS BEFORE FIRST USE.  
KEEP THIS MANUAL FOR FUTURE REFERENCE.  
KEEP AWAY FROM CHILDREN.**



**WEAR CSA APPROVED  
EYE PROTECTION**



**WEAR EAR  
PROTECTION**



**WEAR A  
FACE MASK**

## PRODUCT SPECIFICATIONS

10 CU FT WHEELBARROW	
Pneumatic wheel	16" (39 cm)
Maximum tire inflation	MAX 30 PSI
Axle	5/8" (16 mm)
Maximum Weight Capacity	400 LBS./181 KG
Replacement wheel assembly	HH #5161-068 (sold separately)
Replacement tube	HH #5161-255 (sold separately)
Replacement tire	HH #5161-157 (sold separately)
Replacement bearings	HH #5161-732 (sold separately)
Wheelbarrow weight	46.42 LBS./21.1 KG

## IMPORTANT INFORMATION

- Read all instructions prior to assembly.
- For ease of assembly, it is recommended that 2 people assemble the wheelbarrow.
- Prior to assembly, lay out all parts on a flat, non-abrasive surface and verify that there are no pieces missing.

## NEED ASSISTANCE?

- Technical questions
- Replacement parts
- Parts missing from package

Scan here for support



Email us at: [customerservice@powertoolsplus.ca](mailto:customerservice@powertoolsplus.ca)

Call us on our toll-free customer support line:

1-866-349-8665 (9-5pm Monday-Friday EST)

**⚠ Warning: Do not over inflate tires. Over-inflating beyond maximum PSI can be dangerous.**











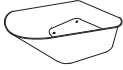

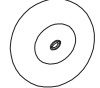

**⚠ Warning: Exceeding maximum weight capacity may result in injury or damage.**

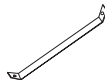
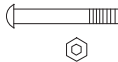
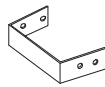
**Care Instructions: After use, clean with a damp, soft cloth or sponge. Rinse thoroughly. When not in use, store in a dry and sheltered location. If wheelbarrow must be stored outdoors, place upright, upside down or sideways to ensure water does not collect in the tray to avoid rust formation.**

## PARTS LIST

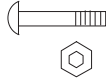
**⚠ WARNING:** When servicing, use only original equipment replacement parts. The use of any other parts may create a safety hazard or cause damage to the wheelbarrow.

For more information, call the Toll-free Helpline, at 1-866-349-8665 – Monday-Friday from 9am to 5pm Eastern Standard Time or email us at [customerservice@powertoolsplus.ca](mailto:customerservice@powertoolsplus.ca).

Key	Part	Description	Qty.	Key	Part	Description	Qty.
A		Tray	1	I		Front short Steel strap	1
B		Wheel	2	J		Rear long Steel strap	1
C		Leg brace	1	K		Wheel bracket	2
D		Tray brace	2	O		M8 x 80 mm bolt	4
E		Nose guard	1	P		M8 x 55 mm bolt	4
F		Leg	2	Q		M8 x 25 mm bolt	6
G		Axle	1	S		M8 x 70 mm bolt	4
H		Handle	2	L		Cotter pin	2
				R		Large washer	4

## EXPLODED VIEW

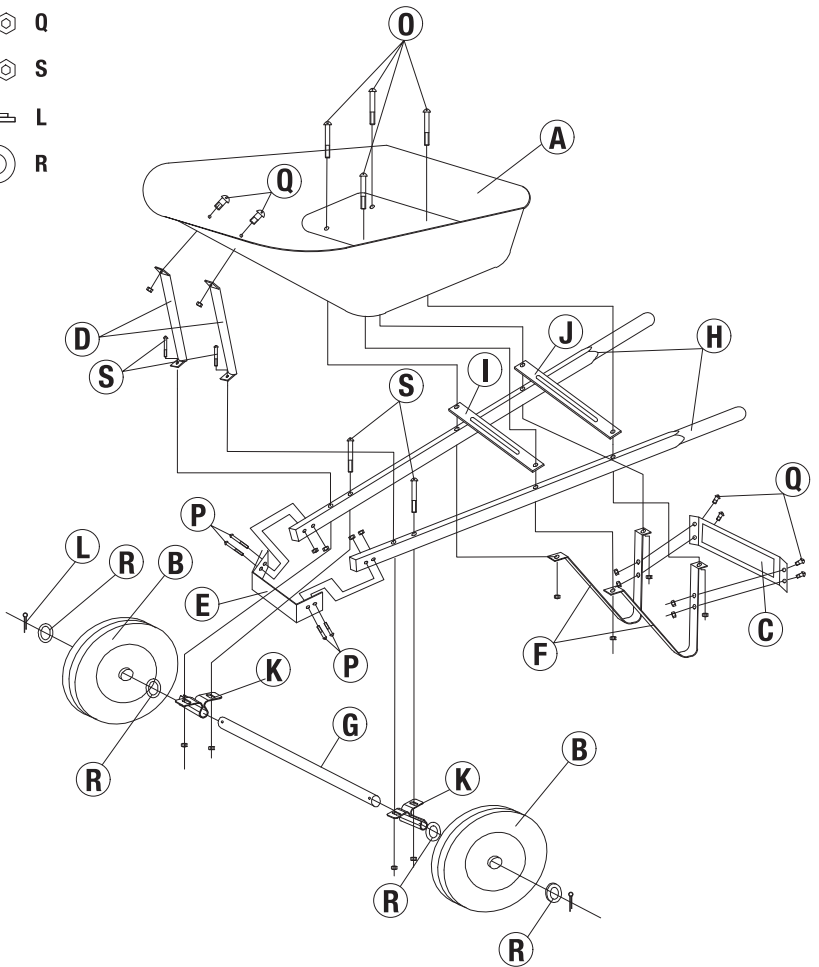
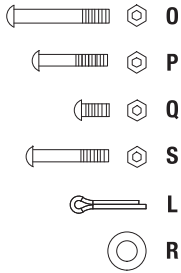

### TOOLS REQUIRED (NOT INCLUDED)

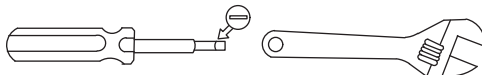

## ASSEMBLY INSTRUCTIONS

**NOTE:** Do not completely tighten bolts until the assembly has been completed.

### STEP 1

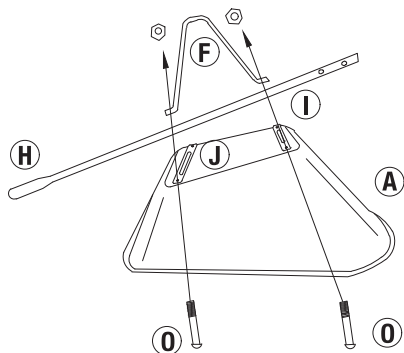

**Repeat for second handle**

### STEP 2

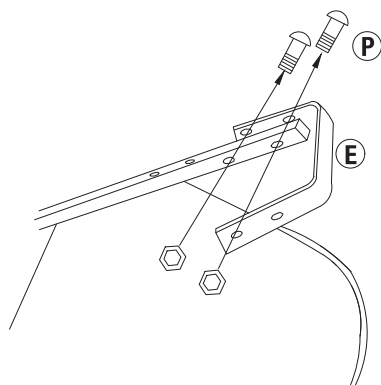

**Nose guard assembly**

## ASSEMBLY INSTRUCTIONS

### STEP 3

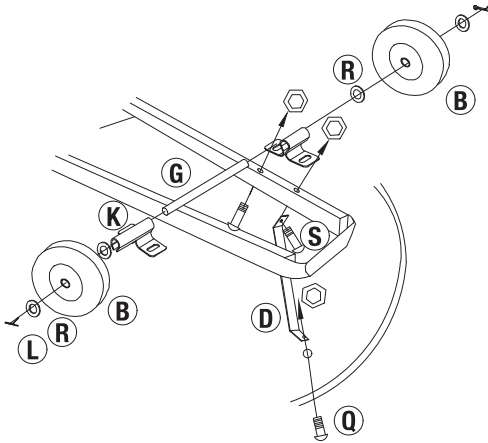

Wheel & tray brace assembly - repeat for second leg

### STEP 4

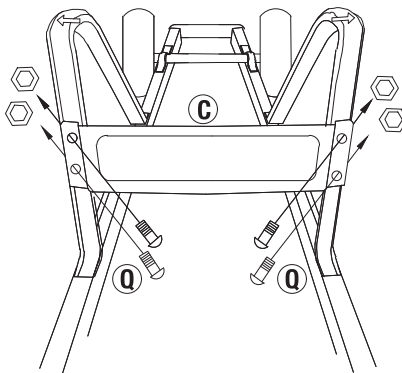

Leg brace assembly

### STEP 5

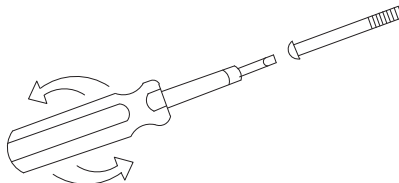

Align parts & tighten all screws securely for safety

## **WARRANTY**

### **BENCHMARK WARRANTY FOR 10 CU FT WHEELBARROW**

If this Benchmark tool fails due to a defect in material or workmanship within 2 years from the date of purchase, return it to any Home Hardware store with the original bill of sale for exchange. This warranty does not include expendable parts including but not limited to blades, brushes, belts, light bulbs.

This warranty covers defects in material or workmanship only. It does not cover normal wear and tear, failure due to abuse/misuse, or defects caused by careless or accidental mishandling. If this Benchmark product is used for commercial or rental purposes, this warranty does not apply.

# 10 CU FT WHEELBARROW



**BENCHMARK**<sup>TM</sup><sub>MC</sub>

**BENCHMARK TOOLS CANADA**  
ST. JACOBS, ONTARIO N0B 2N0  
© 2025 Home Hardware Stores Limited  
CUSTOMER SERVICE/TECH SUPPORT  
1-866-349-8665

**5160-267**

Made in China



\* This Benchmark<sup>TM</sup> product carries a two (2) year LIMITED warranty against defects in workmanship and materials.

**READ ALL INSTRUCTIONS BEFORE FIRST USE.**  
**KEEP THIS MANUAL FOR FUTURE REFERENCE.**  
**KEEP AWAY FROM CHILDREN.**



**WEAR CSA APPROVED  
EYE PROTECTION**



**WEAR EAR  
PROTECTION**



**WEAR A  
FACE MASK**