

BENCHMARKTM MC

6 CU FT SEAMLESS TRAY WHEELBARROW



Item # 5160-263

**READ ALL INSTRUCTIONS BEFORE FIRST USE.
KEEP THIS MANUAL FOR FUTURE REFERENCE.
KEEP AWAY FROM CHILDREN.**



**WEAR CSA APPROVED
EYE PROTECTION**



**WEAR EAR
PROTECTION**



**WEAR A
FACE MASK**

NEED ASSISTANCE?

Call us on our toll-free customer support line:
1-866-349-8665 (Monday through Friday 9am – 5pm Eastern Standard Time)

- Technical questions
- Replacement parts
- Parts missing from package

IMPORTANT INFORMATION

- Read all instructions prior to assembly.
- For ease of assembly, it is recommended that 2 people assemble the wheelbarrow
- Prior to assembly, lay out all parts on a flat, non-abrasive surface and verify that there are no pieces missing.

6 CU FT SEAMLESS TRAY WHEELBARROW

| | |
|-------------------------|---------------|
| Flat-free wheels | 16" (39 cm) |
| Axle | 5/8" (16mm) |
| Maximum Weight Capacity | 450LBS./204KG |









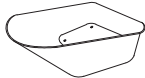
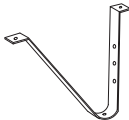

WARNING: EXCEEDING MAXIMUM WEIGHT CAPACITY MAY RESULT IN INJURY OR DAMAGE.

CARE INSTRUCTIONS: AFTER USE, CLEAN WITH A DAMP, SOFT CLOTH OR SPONGE. RINSE THOROUGHLY. WHEN NOT IN USE, STORE IN A DRY AND SHELTERED LOCATION. IF WHEELBARROW MUST BE STORED OUTDOORS, PLACE UPRIGHT, UPSIDE DOWN OR SIDEWAYS TO ENSURE WATER DOES NOT COLLECT IN THE TRAY TO AVOID RUST FORMATION.



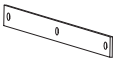

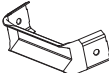

PARTS LIST

⚠ WARNING: When servicing, use only original equipment replacement parts. The use of any other parts may create a safety hazard or cause damage to the wheelbarrow.

For more information, call the Toll-free Helpline, at 1-866-349-8665 – Monday-Friday from 9am to 5pm Eastern Standard Time.

| KEY | PART | DESCRIPTION | QTY. | KEY | PART | DESCRIPTION | QTY. |
|-----|-------------------------------------------------------------------------------------|--------------|------|-----|-------------------------------------------------------------------------------------|----------------|------|
| A |  | Tray | 1 | H |  | Leg | 2 |
| B |  | Wheel | 1 | | | | |
| C |  | Impact board | 1 | I |  | Leg stabilizer | 2 |
| D |  | Tray brace | 2 | | | | |
| E |  | Leg brace | 2 | J |  | Handle | 2 |
| F |  | Wedge | 2 | | | | |
| G |  | Nose guard | 1 | K |  | Axle | 1 |
| | | | | | | | |
| | | | | L |  | Axle bracket | 2 |
| | | | | | | | |

HARDWARE LIST

| | | | | | | | |
|---|-------------------------------------------------------------------------------------|--------------------------------|---|---|-------------------------------------------------------------------------------------|----------------------|---|
| M |  | M8x140mm Carriage bolt, nut | 2 | P |  | M8x70mm Bolt, nut | 4 |
| | | | | Q |  | M8x55mm Bolt, nut | 2 |
| N |  | M8x100mm Carriage bolt, nut | 2 | R |  | M8x25mm Bolt, nut | 4 |
| | | | | S |  | M8x20mm Bolt, nut | 3 |
| O |  | M8x25mm Carriage bolt, nut | 2 | | | | |

EXPLODED VIEW

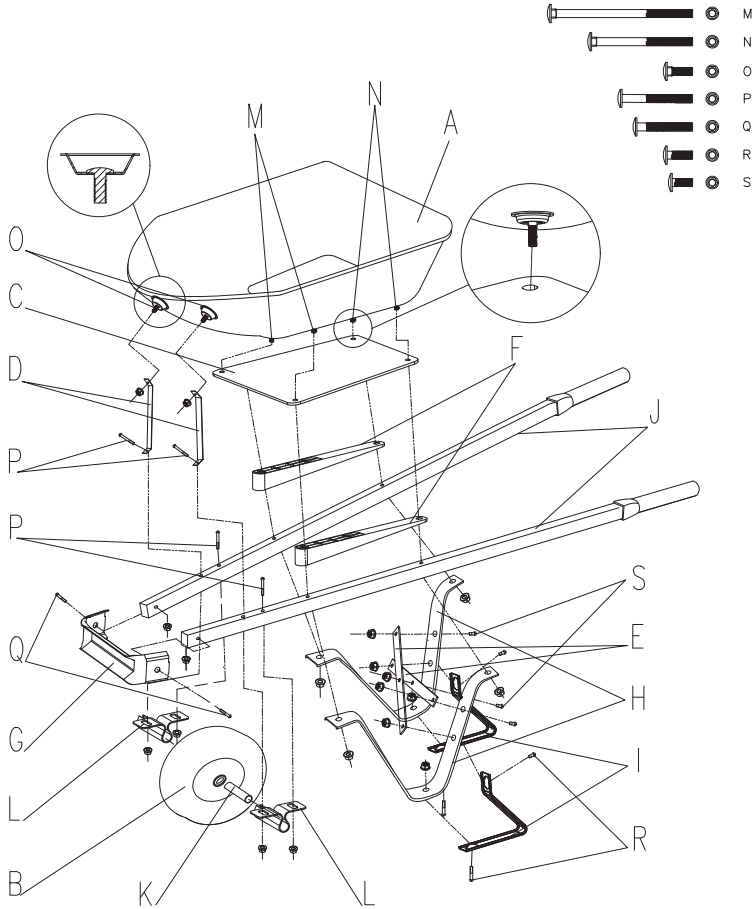

ASSEMBLY INSTRUCTIONS

STEP 1

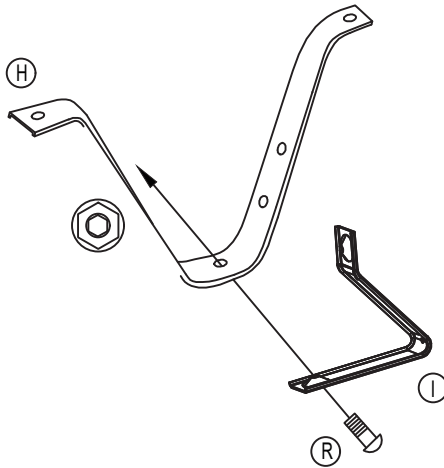

REPEAT FOR SECOND LEG

STEP 2

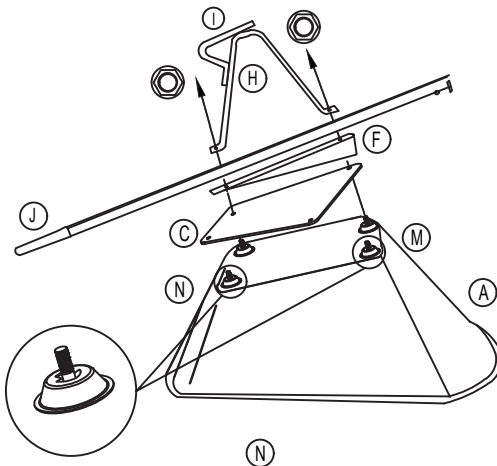

REPEAT FOR SECOND HANDLE

ASSEMBLY INSTRUCTIONS

STEP 3

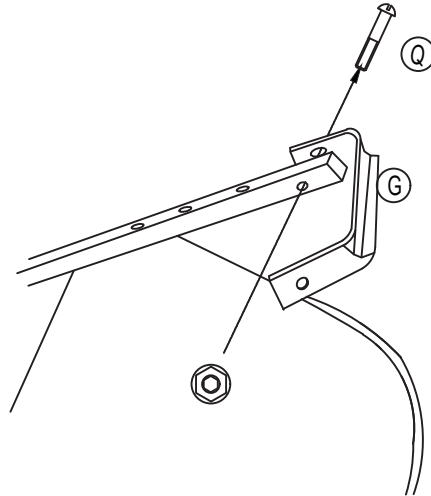

NOSE GUARD ASSEMBLY

STEP 4

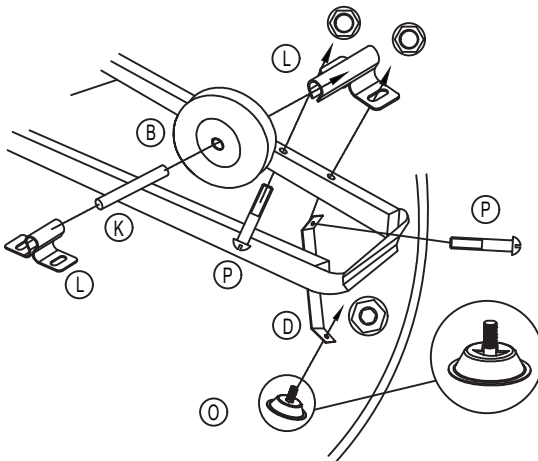

WHEEL & TRAY BRACE ASSEMBLY - REPEAT FOR SECOND TRAY BRACE

ASSEMBLY INSTRUCTIONS

STEP 5

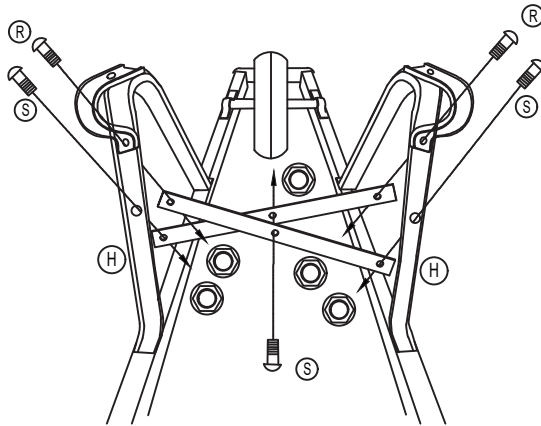

LEG BRACE ASSEMBLY

STEP 6

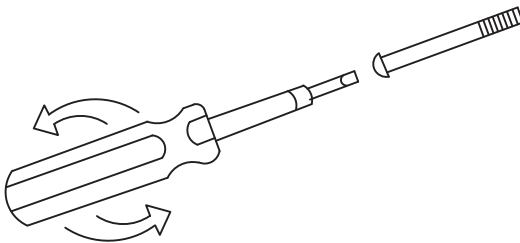

ALIGN PARTS AND TIGHTEN ALL BOLTS SECURELY FOR SAFETY

WARRANTY

BENCHMARK WARRANTY FOR 6 CU FT SEAMLESS TRAY WHEELBARROW

If this Benchmark tool fails due to a defect in material or workmanship within 2 year from the date of purchase, return it to any Home Hardware store with the original bill of sale for exchange. This warranty does not include expendable parts including but not limited to blades, brushes, belts, light bulbs.

This warranty covers defects in material or workmanship only. It does not cover normal wear and tear, failure due to abuse/misuse, or defects caused by careless or accidental mishandling. If this Benchmark product is used for commercial or rental purposes, this warranty does not apply.

6 CU FT SEAMLESS TRAY WHEELBARROW



BENCHMARKTM_{MC}

BENCHMARK TOOLS CANADA
ST. JACOBS, ONTARIO N0B 2N0
© 2023 Home Hardware Stores Limited

5160-263

Made in China

**READ ALL INSTRUCTIONS BEFORE FIRST USE.
KEEP THIS MANUAL FOR FUTURE REFERENCE.
KEEP AWAY FROM CHILDREN.**



**WEAR CSA APPROVED
EYE PROTECTION**



**WEAR EAR
PROTECTION**



**WEAR A
FACE MASK**