

HOME ESSENTIALS

5 CU FT DUAL WHEEL WHEELBARROW



Item # 5160-261

READ ALL INSTRUCTIONS BEFORE FIRST USE.

KEEP THIS MANUAL FOR FUTURE REFERENCE.

KEEP AWAY FROM CHILDREN.



**WEAR CSA APPROVED
EYE PROTECTION**



**WEAR EAR
PROTECTION**



**WEAR A
FACE MASK**

NEED ASSISTANCE?

Call us on our toll-free customer support line:

1-866-349-8665 (Monday through Friday 9am – 5pm Eastern Standard Time)

- Technical questions
- Replacement parts
- Parts missing from package

IMPORTANT INFORMATION

- Read all instructions prior to assembly.
- For ease of assembly, it is recommended that 2 people assemble the wheelbarrow
- Prior to assembly, lay out all parts on a flat, non-abrasive surface and verify that there are no pieces missing.

5 CU FT WHEELBARROW	
Pneumatic wheel	16" (39 cm)
Maximum tire inflation	MAX 30 PSI
Axle	5/8" (16 mm)
Maximum Weight Capacity	250LBS./113.4KG

 **WARNING: Do not over inflate tires. Over-inflating beyond maximum PSI can be dangerous.**







 **WARNING: Exceeding maximum weight capacity may result in injury or damage.**

Care Instructions: After use, clean with a damp, soft cloth or sponge. Rinse thoroughly. When not in use, store in a dry and sheltered location. If wheelbarrow must be stored outdoors, place upright, upside down or sideways to ensure water does not collect in the tray to avoid rust formation.

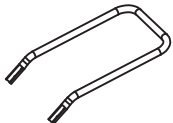
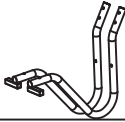
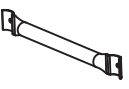
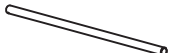
PARTS LIST

⚠ WARNING: When servicing, use only original equipment replacement parts. The use of any other parts may create a safety hazard or cause damage to the wheelbarrow.

For more information, call the Toll-free Helpline, at 1-866-349-8665 – Monday-Friday from 9am to 5pm Eastern Standard Time.

KEY	Part	Description	QTY
A	Handle		1
B	Leg		2
C	Leg brace		1
D	Axle		1
E	Tray		1
F	Wheel		2
G	M8 x 55 mm Bolt, Nut		6
H	M8 x 50 mm Bolt, Nut		2
I	16 mm Washer		4
J	Pin		2

EXPLODED VIEW

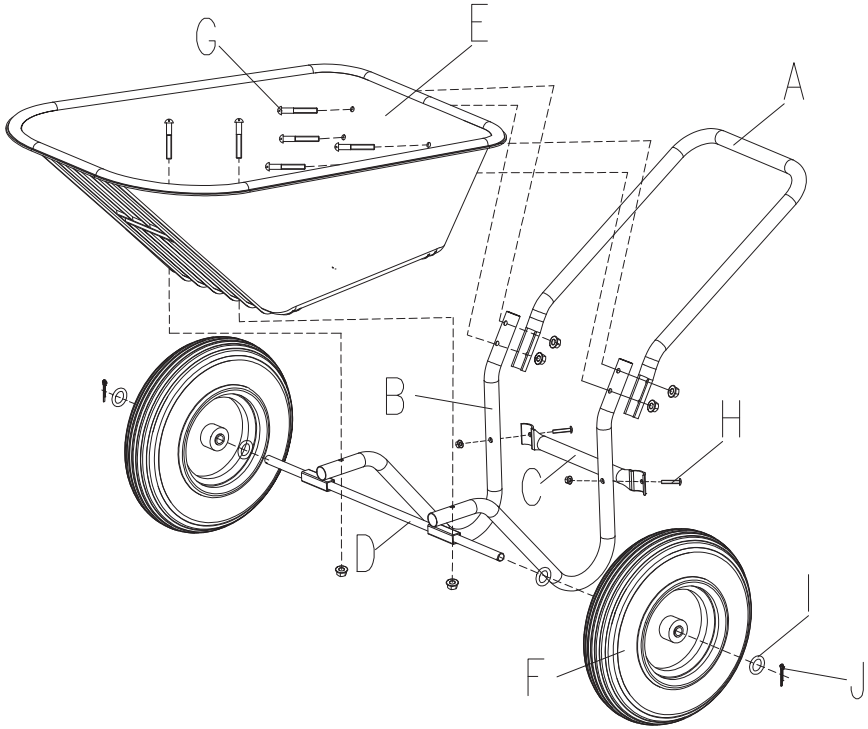

ASSEMBLY INSTRUCTIONS

STEP 1

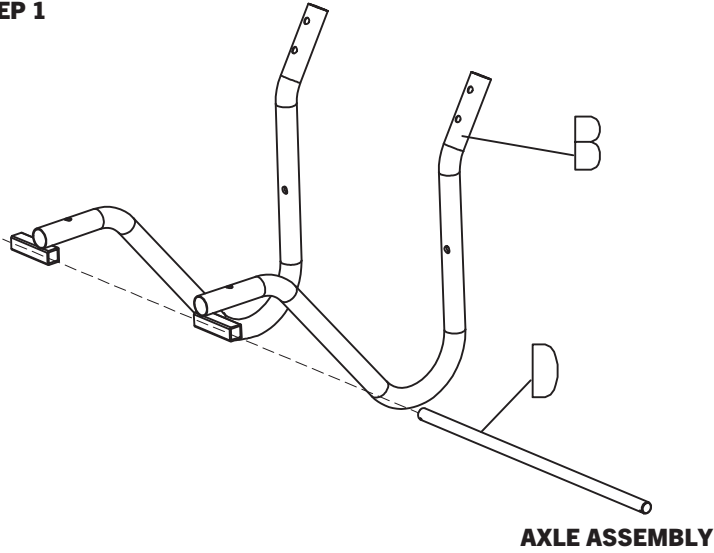

STEP 2

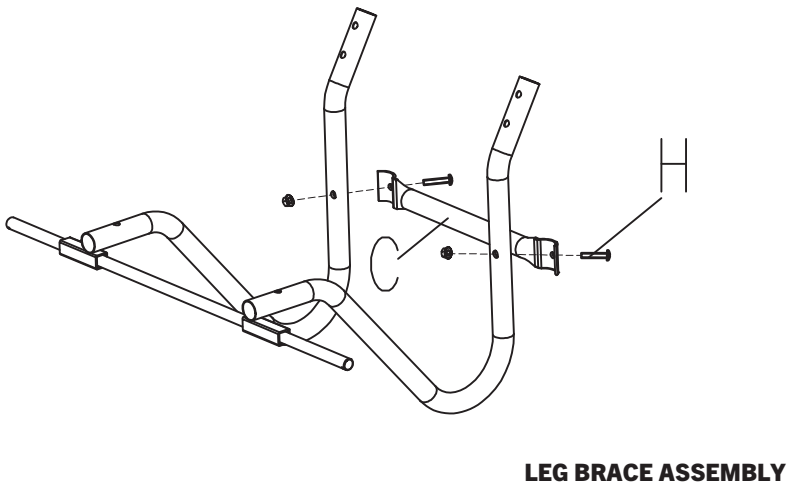

ASSEMBLY INSTRUCTIONS

STEP 3

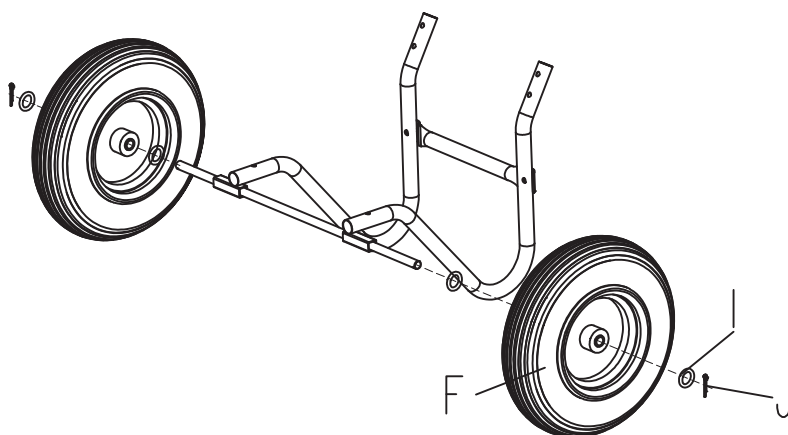

WHEEL ASSEMBLY

STEP 4

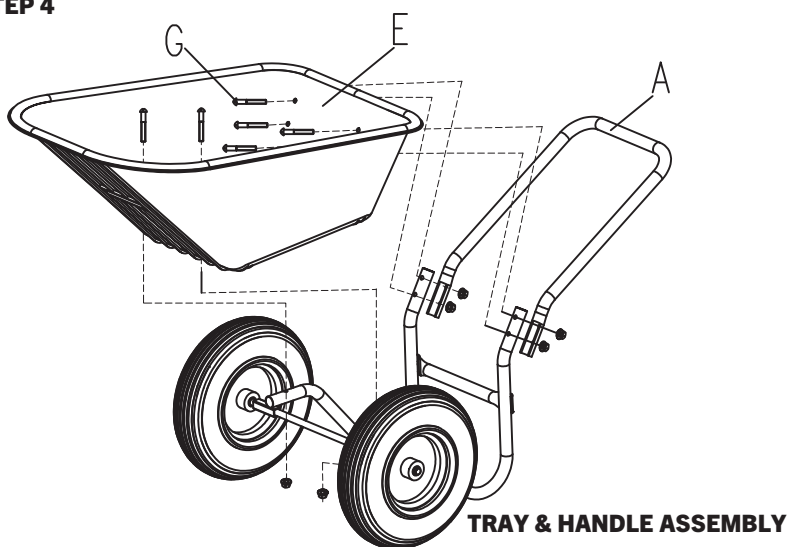

TRAY & HANDLE ASSEMBLY

WARRANTY

HOME ESSENTIALS WARRANTY FOR 5 CU FT DUAL WHEEL WHEELBARROW

If this Home Essentials tool fails due to a defect in material or workmanship within 1 year from the date of purchase, return it to any Home Hardware store with the original bill of sale for exchange. This warranty does not include expendable parts including but not limited to blades, brushes, belts, light bulbs.

This warranty covers defects in material or workmanship only. It does not cover normal wear and tear, failure due to abuse/misuse, or defects caused by careless or accidental mishandling. If this product is used for commercial or rental purposes, this warranty does not apply.

5 CU FT DUAL WHEEL WHEELBARROW



HOME ESSENTIALS CANADA
ST. JACOBS, ONTARIO N0B 2N0
©2023 Home Hardware Stores Limited

5160-261

Made in China

**READ ALL INSTRUCTIONS BEFORE FIRST USE.
KEEP THIS MANUAL FOR FUTURE REFERENCE.
KEEP AWAY FROM CHILDREN.**



**WEAR CSA APPROVED
EYE PROTECTION**



**WEAR EAR
PROTECTION**



**WEAR A
FACE MASK**