

# BENCHMARK<sup>TM</sup> MC

## 13 AMP ELECTRIC DETHATCHER



5 Year Limited Warranty



**READ ALL INSTRUCTIONS BEFORE FIRST USE.  
KEEP THIS MANUAL FOR FUTURE REFERENCE.  
KEEP AWAY FROM CHILDREN.**



**WEAR CSA APPROVED  
EYE PROTECTION**



**WEAR EAR  
PROTECTION**



**WEAR A  
FACE MASK**

## PRODUCT SPECIFICATIONS

<b>13 AMP ELECTRIC DETHATCHER</b>	
Rating voltage	120 V~60 Hz
Rating current	13 A
No load speed	3500 RPM
Deck width	19" (47.5 cm)
Cutting width	15" (38 cm)
Dethatching depth	-12 / -9 / -6 / -3 / +6 mm, 5 positions
Dethatcher blade diameter	5.2" (13.2 cm)
Weight	32 lb (14.5 kg)
Grass bag	45 L
Protection degree	

### NEED ASSISTANCE?

Call us on our toll free customer support line:

1-833-818-4111 (Monday through Friday, 9am – 5pm, Eastern Standard Time)

- Technical questions
- Replacement parts
- Parts missing from package

**TABLE OF CONTENTS**

Product Specifications ..... 1  
Table of Contents ..... 2  
Safety Instructions ..... 3  
Symbols ..... 3  
General Safety Warnings ..... 6  
Know Your Dethatcher ..... 9  
Operation Instructions ..... 10  
Maintenance ..... 16  
Troubleshooting..... 18  
Exploded View ..... 19  
Parts ..... 20  
Warranty ..... 24

## SAFETY INSTRUCTIONS

### IMPORTANT





Please read these instructions fully before assembling and operating.

### DESCRIPTION OF SYMBOLS

Symbols are used in this manual to attract your attention to possible risks. The safety symbols and the explanations which accompany them must be perfectly understood. The warnings themselves do not prevent the risks and cannot be a substitute for proper methods of avoiding accidents.

### SAFETY ALERT SYMBOLS









The following symbols are used on the product and in this manual to alert the operator of potential safety hazards. Read them carefully, and understand their meaning.





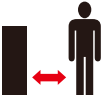

SYMBOL	MEANING
	<b>DANGER</b> Indicates an imminently hazardous situation which, if not avoided, will result in death or serious injury.
	<b>WARNING!</b> Indicates a potentially hazardous situation which, if not avoided, could result in death or serious injury.
	<b>CAUTION</b> Indicates a potentially hazardous situation which, if not avoided, may result in minor/moderate injury.
	<b>NOTICE</b> Indicates a practice not related to personal injury which, if not avoided, may result in property damage.

The following symbols may be found on your dethatcher. Carefully read and understand their meaning.



## SYMBOLS

Some of the following symbols may be used on this product. Please study them and learn their meaning. Proper interpretation of these symbols will allow you to operate the product effectively and safely.

SYMBOL	MEANING
	READ THE OPERATOR'S MANUAL(S) – Read, understand, and follow all instructions in the user manual(s) before attempting to assemble and operate.
	SAFETY ALERT – Indicates a precaution, a warning, or a danger.
	WARNING! Do not expose the unit to rain or wet conditions.
	WEAR EYE AND HEARING PROTECTION – For protection against injury, wear ear defenders and safety goggles.
	Wear protective gloves and non-slip footwear when using the machine and handling debris
	DANGER! Rotating blades –Keep hands and feet away from moving parts.
	Keep bystanders a safe distance away from the work area.
	Thrown objects picked up by the rotating tines can cause severe injury.

	Inspect the work area prior to use and remove all objects that could be thrown by the appliance. If a hidden object is discovered while working, stop the engine and remove the object.
	Use extreme CAUTION when reversing or pulling the machine towards you.
	SWITCH OFF! Remove plug from outlet before cleaning or conducting maintenance checks.
	SWITCH OFF! Remove plug from outlet immediately if the cord is damaged or cut.
	Do not push down stairs
	DOUBLE INSULATION.

## GENERAL SAFETY WARNINGS

-  **WARNING:** When using electric garden products, basic safety precautions should always be followed to reduce the risk of fire, electric shock and personal injury, including the following:
-  **WARNING:** Read all instructions.
-  **WARNING:** This product can expose you to chemicals including lead, phthalate or bisphenol A which are known to cause cancer, birth defects or other reproductive harm. Wash your hands after use.

### FOR ALL DETHATCHERS

1. Avoid Dangerous Environments - Do not use appliances in damp or wet locations.
2. Do not Use In Rain.
3. Keep Children Away - All visitors should be kept at a distance from work area.
4. Dress Properly - Do not wear loose clothing or jewellery. They can be caught in moving parts. Use of rubber gloves and substantial footwear is recommended when working outdoors. Wear protective hair covering to contain long hair.
5. Use Safety Glasses - Always use face or dust mask if operation is dusty.
6. Use the Right Dethatcher - Do not use dethatcher for any job except that for which it is intended.
7. Ground Fault Circuit Interrupter (GFCI) protection should be provided on the circuit(s) or outlet(s) to be used for the gardening appliance. Receptacles are available having built-in GFCI protection and may be used for this measure of safety.

Table 1  
Minimum gauge for extension cords

Volts	Total length of cord			
	25' 7.2 m	50' 15.2 m	100' 30.4 m	150' 45.7 m
Ampere rating more than not more than	AWG			
0-6	N/A	16	16	14
6-10	N/A	16	14	12
10-12	16	16	14	12
12-16	14	12	Not recommended	

8. Warning - To reduce the risk of electric shock, use only with an extension cord intended for outdoor use, such as an extension cord of cord type SW-A SOW-A, STW-A, STOW-A, SJW-A, SJOW-A, SJTW-A, or SJTOW-A.
9. Extension Cord - Make sure your extension cord is in good condition. When using an extension cord, be sure to use one heavy enough to carry the current your product will draw. An undersized extension cord will cause a drop in line voltage resulting in loss of power and overheating. Table 1 shows the correct size to use depending on cord length and nameplate ampere rating. If in doubt, use the next heavier gauge. The smaller the gauge number, the heavier the cord. To reduce the risk of disconnection of appliance cord from the extension cord during operating: i) Make a knot as shown in Figure 1.

### **SAVE THESE INSTRUCTIONS FOR REFERENCE**

- ii) Use one of the plug-receptacle retaining straps or connectors described in this manual.
10. Avoid Unintentional Starting - Do not carry plugged-in dethatcher with finger on switch. Be sure switch is off when plugging in.
11. Do not Abuse Cord - Never carry dethatcher by cord or yank it to disconnect from receptacle. Keep cord from heat, oil, and sharp edges.
12. Do not grasp the exposed cutting blades or cutting edges when picking up or holding the dethatcher.
13. It should work in constant speed - It will do the job properly and safer at the rate for which it was designed.
14. Do not Overreach - Keep proper footing and balance at all times.
15. Stay Alert - Watch what you are doing. Use common sense. Do not operate dethatcher when you are tired.
16. Disconnect Dethatcher - Disconnect the dethatcher from the power supply when not in use, before servicing, when changing accessories such as blades, and the like.
17. Store Idle Dethatcher Indoors - When not in use, dethatcher should be stored indoors in dry, and high or locked-up place - out of reach of children.
18. Maintain Dethatcher With Care - Keep cutting edge sharp and clean for best performance and to reduce the risk of injury. Follow instructions for lubricating and changing accessories. Inspect appliance cord periodically, and if damaged, have it repaired by an authorized service facility. Inspect extension cords periodically and replace if damaged. Keep handles dry, clean, and free from oil and grease.
19. Check Damaged Parts - Before further use of the dethatcher, a guard or other part that is damaged should be carefully checked to determine that it will operate properly and perform its intended function. Check for alignment of moving parts, binding of moving parts, breakage of parts, mounting, and any other condition that may affect its operation. A guard or other part that is damaged should be properly repaired or replaced by an authorized service center unless indicated elsewhere in this manual.



**⚠ WARNING:** Read all safety warnings and instructions. Failure to follow the warnings and instructions may result in electric shock, fire and/or serious injury.

**FOR ALL DOUBLE-INSULATED DETHATCHERS**

- 1) Replacement Parts - When servicing use only identical replacement parts.
- 2) Polarized Connections - To reduce the risk of electric shock, this dethatcher has a polarized plug (one blade is wider than the other) and will require the use of a polarized extension cord. The plug will fit into a polarized extension cord only one way. If the plug does not fit fully into the extension cord, reverse the plug. If the plug still does not fit, obtain a correct polarized extension cord. A polarized extension cord will require the use of a polarized wall outlet. This plug will fit into the polarized wall outlet only one way. If the plug does not fit fully into the wall outlet, reverse the plug. If the plug still does not fit, contact a qualified electrician to install the proper wall outlet. Do not change the equipment plug, extension cord receptacle, or extension cord plug in any way.

Figure 1. Method of Securing Extension Cord Cord set

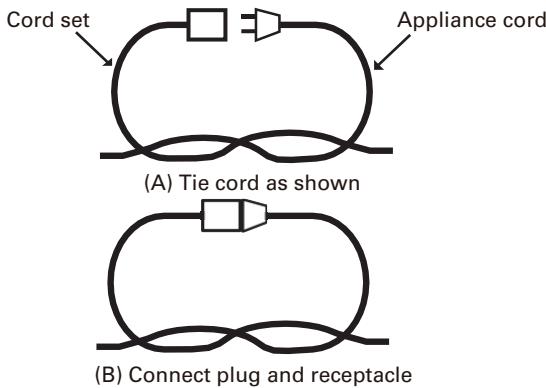

## KNOW YOUR ELECTRIC DETHATCHER

Read the owner's manual and safety instructions carefully before operating the electric dethatcher. Compare the illustration below to the electric dethatcher in order to familiarize yourself with the location of the various controls and adjustments. Save this manual for future reference.

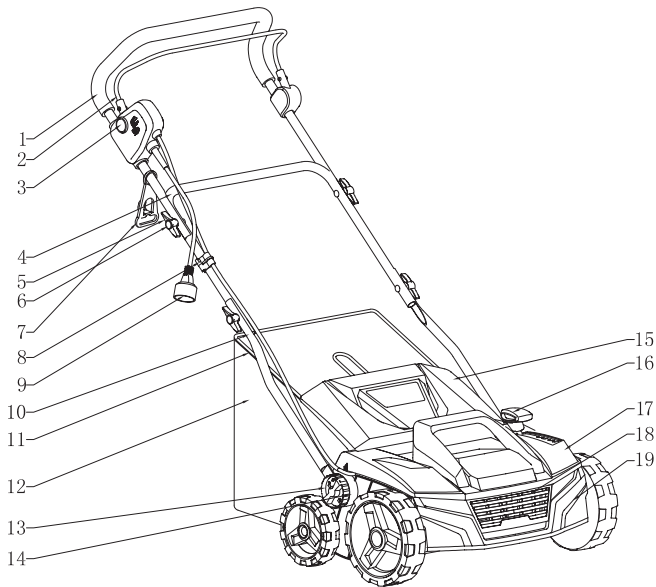

- |                                    |                                   |
|------------------------------------|-----------------------------------|
| 1. Upper handle                    | 11. Thatch bag rack               |
| 2. Switch lever                    | 12. Thatch bag                    |
| 3. Safety lock button              | 13. Angle knob                    |
| 4. Middle handle                   | 14. Fixed knob                    |
| 5. Knob x 4                        | 15. Thatch bag cover              |
| 6. Bolt                            | 16. Raking depth adjustment lever |
| 7. Extension cord restraint holder | 17. Cover                         |
| 8. Cable clip                      | 18. Decorative plates             |
| 9. Plug                            | 19. Base                          |
| 10. Lower handle                   |                                   |

Not all the accessories illustrated or described are included in standard delivery.

## OPERATING INSTRUCTIONS

**NOTE:** Read operator's manual

### INTENDED USE

This product is intended for domestic, dethatching of lawn. This appliance is not intended for dethatching on hard materials such as steel rod, stones and other hard materials which exceeds its cutting capacity and will damage the tines.



### WARNING

To avoid injury from unexpected starting or electrical shock, during assembly or adjustment, do not plug the power cord into a source of power.

## ASSEMBLY

### Assemble the lower handle

1. Install the lower handle positioning seat on the base, Note: There are 3 gears at the base installation position, which represent 3 different installation heights.

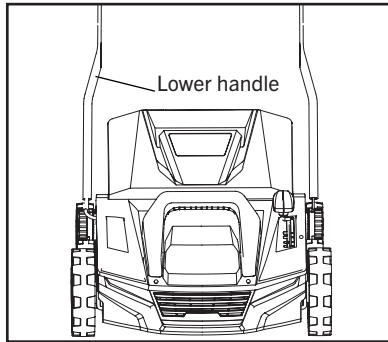

2. Tighten the angle knob clockwise to fix it on the base.  
Note: The rotation direction of loosening and locking is marked on the angle knob.

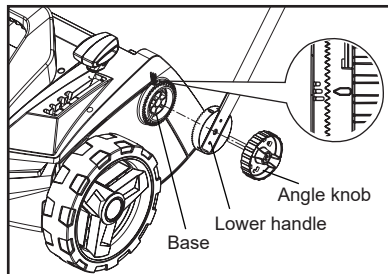

## Assemble the middle handle

1. Install the middle handle onto the lower handle by tightening the knob and the bolt.

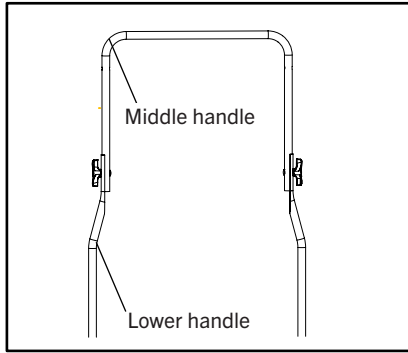

2. Knob installation: Disassemble the knob assembly, pass the bolt through the inside of the middle, and then turn the knob clockwise to the screw to fix the second handle. Same installation on the other side.

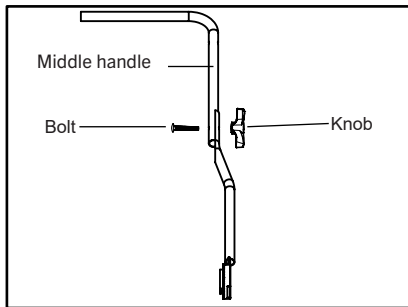

## Assemble upper handle and cable clip

1. Install the upper handle on the outside of the middle handle. Install the extension cord restraint holder on the same side as the switch.

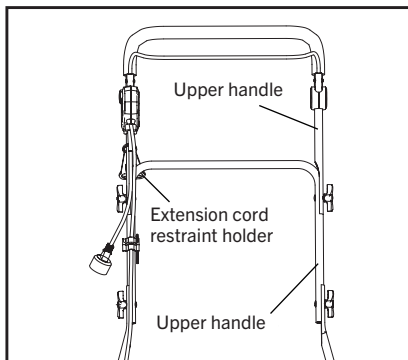

- 2. Pass the power cord through the cable clip, then clamp the cable clip on the left side of the middle handle.

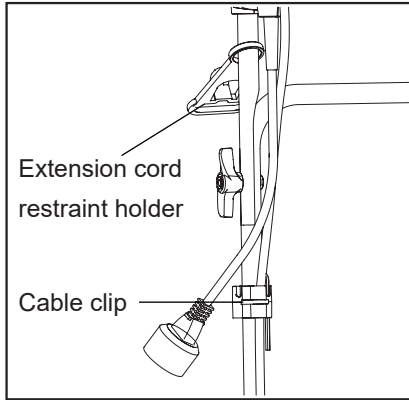

**Installing the thatch collection bag**

**! WARNING**

The product must be switched off and the cutting device must have stopped rotating before you attach or empty the thatch collection bag.

**NOTE:** A full thatch collection bag will reduce the performance of this product.

**NOTE:** You have the option of operating the thatcher with or without the collection bag.

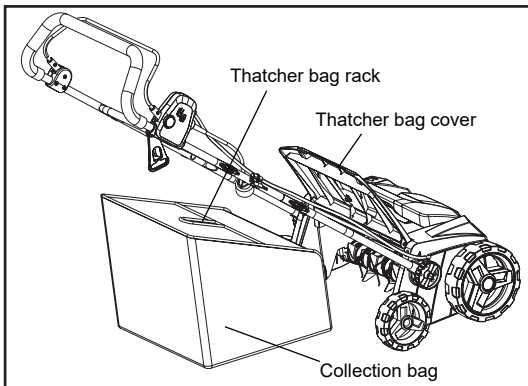

**NOTE:** Install the extension cord retainer to upper handle with wire side before assembling the upper handle with lower handle.

Attach the thatch collection bag to the dethatcher before operation. Lift the thatch collection bag cover, and hang the thatch collection bag on the mounting hooks. Empty the thatch collection bag frequently during use. Do not wait until it is completely full. We recommend emptying it when it is half full.

Lift the thatch collection bag cover and pull the thatch collection bag off the mounting hooks to remove it.

Empty the bag's contents into a suitable waste receptacle. Mount the bag back into position before resuming work.

## Adjusting the gears



### WARNING

The unit must be switched off and disconnected from the power supply before adjusting the tine settings.

Adjust the depth according to the needs of your lawn. The most suitable depth depends on the kind of lawn and the actual height of the grass.

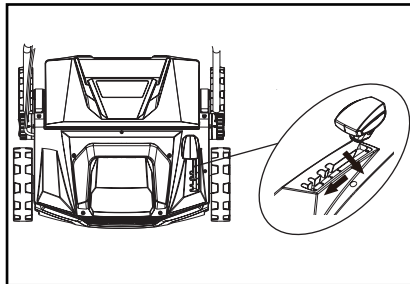

Scale/ Position	Setting	Application	
		Depth	Raking
1	high	6 mm	transport, removing thin layers of thatch
2	minimal	-3 mm	raking healthy lawn
3	middle	-6 mm	storage and raking
4	deep	-9 mm	storage and raking
5	deep	-12 mm	storage and raking deep layers of thatch

**Starting + Stopping****WARNING**

Before switching on the lawn dethatcher, make sure that it is not in contact with any foreign objects. Keep your feet and hands a safe distance away from the rotating tines and the ejector opening. Failure to comply with these warnings can result in severe personal injury.

**To start**

1. Keep pressing safety lock button.
2. With the safety lock button pressed, simultaneously pull the switch lever back with the other hand on the upper handle. Hold the switch lever and upper handle together to operate.

**To stop**

1. Release the switch lever to stop and make sure the tines come to a complete stop.

**WARNING**

The tine cylinder continues to run for a brief period after the unit has been switched off. Do not tilt or carry the unit while the motor is still running and do not touch the cylinder while it is still rotating. Failure to comply could result in severe personal injury.

**Overload Protection**

The overload protection will be activated in the following circumstances:

1. A buildup of scarified material around the cutting device.
2. If the material scarified is larger than the motor capacity.
3. Where there is too much resistance against the cutting device.

When the circuit breaker has been activated switch off the product and disconnect from the power supply.

Let the product cool down and eliminate the cause before using the product again.

**General Operation****WARNING**

If the product strikes a foreign object stop the motor. Switch the product off, disconnect it from the power supply and let it cool down. Inspect the product thoroughly for damage. Have any damage repaired before restarting.

**WARNING**

Extensive vibration of the product during operation is an indication of damage. The product should be promptly inspected and repaired.

- Check the machine, its power cord and plug as well as accessories for damage before each use. Do not use the machine if it is damaged or shows wear.
- Double check that accessories are properly fixed.

- Push the machine forward by its handle. Keep the handle dry to ensure safe support.  
Ensure that the air vents are always unobstructed and clear. Clean them if necessary with a soft brush. Blocked air vents may lead to overheating and damage the product.
- Switch the machine off immediately if you are disturbed while working by other people entering the working area. Always let the machine come to complete stop before putting it down.
- Do not overwork yourself. Take regular breaks to ensure you can concentrate on the work and have full control over the machine.
- Mow the lawn before working and fertilize afterwards.
- Make sure that the lawn is clear of stones, sticks, wire, or other objects that could damage the machine or its motor.
- Select the suitable cutting depth for the actual grass height.
- Do not work with this machine on a wet lawn because it tends to stick to the underbody of the machine, preventing the proper discharge of collected material, and it could also cause you to slip and fall.
- Slowly push the machine forward. Move the machine at appropriate speed. Do not move it too fast to prevent the discharge from getting blocked and engine from useless overloading.
- Work in slight overlapping rows. The most effective pattern for raking lawns is straight lines along one of the sides. This will keep the rows even and ensures that all the lawn is raked without missing any spots.

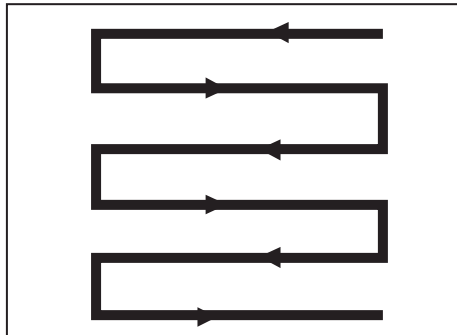

- Circle around flower beds. When reaching a flower bed in the middle of the lawn, make a row or two around the circumference of the bed.
- Pay special attention when changing direction.



## MAINTENANCE



### WARNING

Before carrying out any repairs or servicing work, you must ensure that the machine has been disconnected from the power supply. Repairs and maintenance work other than described within this instruction manual may be performed only by qualified specialist!

### Service + Storage

To ensure long and reliable service, carry out the following maintenance regularly. Servicing and cleaning work on the machine and the removal of the guards may only be carried out after the motor has been switched off and the plug disconnected from the power supply.

- Keep all nuts, bolts and screws tight to be sure the product is in a safe working condition.
- Allow the product to cool before storing in any enclosure.
- Check the thatch collection bag frequently for wear or deterioration.
- Examine the product regularly and replace worn or damaged parts for safety.
- Check that covers and guards are undamaged and correctly fitted. Carry out necessary maintenance or repairs before using the machine.
- If the cutting device should happen to fail despite the care taken in manufacturing and testing, repair should be carried out by an authorized repair facility.
- Do not clean the machine while it is running.
- Ensure that all the fastening elements (screws, nuts, etc.) are tight at all times so that you can safely work with the machine.
- Check the machine frequently for signs of wear. Replace worn or damaged parts.
- Store your machine in a dry place. To ensure a long service life all screws and bolts should be cleaned and then oiled.
- Clean the machine with a brush or cloth. Do not use any solvents or water to remove dirt.
- The component that is subject to most wear is the cutting device. You should therefore check the condition of the cutting device and its mounting at regular intervals.
- If the cutting device is worn or blunt it must be replaced immediately.
- If the machine starts to suffer from excessive vibrations, this means that the cutting device has not been balanced correctly or has suffered deformation due to impacts. In this case it must be repaired or replaced.

### Replacing/Changing Cutting Device



### WARNING

Always switch the machine off, disconnect it from power supply and let it cool down before changing / replacing the cutting device.



### WARNING

Cutting devices are very sharp and become hot during use. Handle them carefully.



## WARNING

Wear safety gloves when handling cutting devices in order to avoid injuries like burns and cuts.



## WARNING

Make sure all bolts are completely tightened before operating the machine. Don't operate the machine if any bolts are missing, loose, or damaged.

The product is designed for raking and the raking cylinder is preassembled on the machine. The cylinder can be changed according to the application.

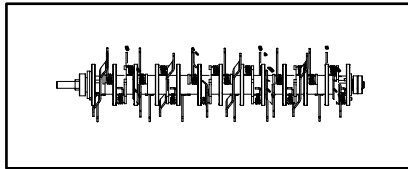

## Replace the raking cylinder

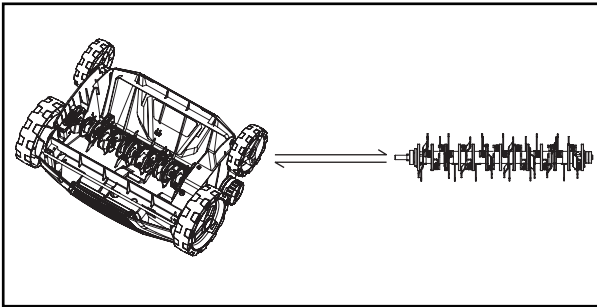

1. Loosen the inner hexagon on the bearing seat and unscrew it counterclockwise.
2. Then take out the raking cylinder.
3. Align the rectangular hole at one end of the comb blade with the square output shaft on the base.
4. Press the bearing on the grooming blade into the bearing seat, and then tighten the hexagon socket screw clockwise.

## TROUBLESHOOTING

Fault/Malfunction	Cause(s)	Solution(s)
Motor does not start	<ul style="list-style-type: none"> <li>a) Not connected to power supply</li> <li>b) Power cord or plug is defective</li> <li>c) Other electrical defect to the product</li> <li>d) Safety lock button not pressed</li> </ul>	<ul style="list-style-type: none"> <li>a) Connect to power supply</li> <li>b) Contact an authorized service agent</li> <li>c) Press safety lock button first, then the start/stop lever</li> </ul>
Product does not reach full power	<ul style="list-style-type: none"> <li>a) Extension cord not suitable for operation with this product</li> <li>b) Power source (e.g. generator) has too low voltage</li> <li>c) Air vents are blocked</li> </ul>	<ul style="list-style-type: none"> <li>a) Use a proper extension cord</li> <li>b) Connect to another power source</li> <li>c) Clean the air vents</li> </ul>
Unsatisfying result	<ul style="list-style-type: none"> <li>a) Raking tines worn</li> <li>b) Raking material exceeds capacity</li> <li>c) Lawn has grown too tall</li> </ul>	<ul style="list-style-type: none"> <li>a) Replace the tine cylinder</li> <li>b) Only raking materials according to capacity of the product</li> <li>c) Adjust the depth or mow the lawn before using the dethatcher</li> </ul>

## EXPLODED VIEW

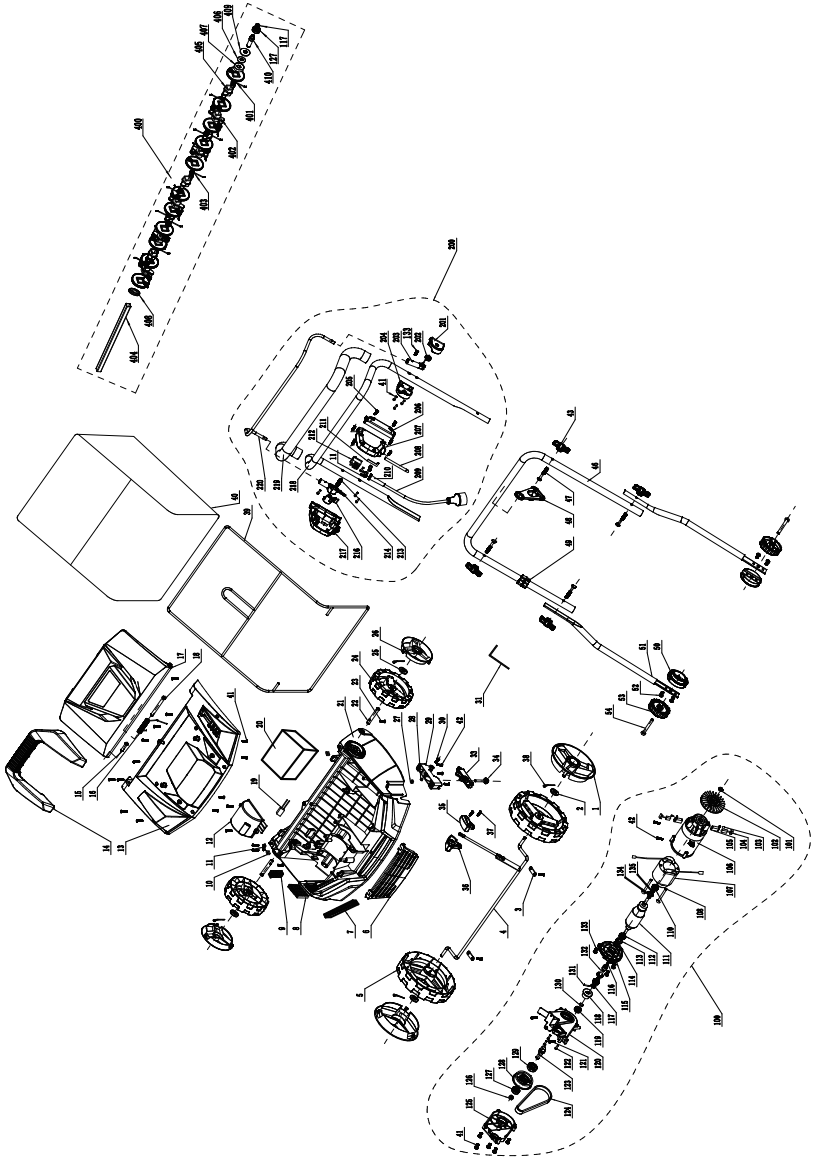

**PARTS LIST**



**WARNING**

When servicing, use only original equipment replacement parts.

The use of any other parts may create a safety hazard or cause damage to the 13 Amp Electric Dethatcher. Any attempt to repair or replace parts on this 13 Amp Electric Dethatcher may create a safety hazard unless repairs are performed by a qualified technician. For more information, call the Toll-free Helpline, at 1-833-818-4111 – Monday-Friday from 9am - 5pm Eastern Standard Time.

Always order by key number.

Number	Part sku	Part name	Quantity
1	BVAO021001	Wheel cover	2
2	BVAO021002	Ø10*Ø20*1.5 gasket	4
3	BVAO021003	Pressplate	2
4	BVAO021004	Front wheel spindle assembly	1
5	BVAO021005	200 Wheel	2
6	BVAO021006	Front decorative panel	1
7	BVAO021007	Filter sponge NO. 2	1
8	BVAO021008	Filter sponge NO. 1	1
9	BVAO021009	Filter sponge NO. 3	1
10	BVAO021010	NUT 12*12*6 M8	2
11	BVAO021011	Pressplate	1
12	BVAO021012	Breakwind	1
13	BVAO021013	Housing cover	1
14	BVAO021014	Housing handle	1
15	BVAO021015	Grass bag fixing pin	1
16	BVAO021016	Spring	1
17	BVAO021017	Grass bag cover	1
18	BVAO021018	Torsion spring fixing pin	1
19	BVAO021019	Protector 17AMD 110Z+PTC	1
20	BVAO021020	Sandbag	1
21	BVAO021021	Base	1
22	BVAO021022	Back wheel spindle	2
23	BVAO021023	Screw ST5*25	2
24	BVAO021024	150 wheel	2
25	BVAO021025	Ø10*Ø20*1.5 gasket	2
26	BVAO021026	Wheel cover	2
27	BVAO021027	NUT M6*5	1
28	BVAO021028	NUT M5	1
29	BVAO021029	Bearing block	1

30	BVAO021030	NUT M5*25	1
31	BVAO021031	Inner hexagon spanner	1
33	BVAO021033	Press plate	1
34	BVAO021034	Nut M6*30	1
35	BVAO021035	Depth adjust handle (right)	1
36	BVAO021036	Depth adjust handle (left )	1
37	BVAO021037	Screw ST4*16	8
38	BVAO021038	R pin Ø2*20mm	4
39	BVAO021039	Grass collect frame	1
40	BVAO021040	Grass collect bag	1
41	BVAO021041	Screw ST4*20	21
42	BVAO021042	Screw ST5*25	3
43	BVAO021043	Knob	4
46	BVAO021046	Middle handle	1
47	BVAO021047	Spring washer	4
48	BVAO021048	Cable strain relief	1
49	BVAO021049	Cable clamp	1
50	BVAO021050	Lower handle seat	2
51	BVAO021051	Lower handle	2
52	BVAO021052	Screw ST5*14	4
53	BVAO021053	Knob	2
54	BVAO021054	Screw M8*50	2
100	BVAO021100	Motor assembly	1
101	BVAO021101	Ring Ø8	1
102	BVAO021102	Motor fan	1
103	BVAO021103	Screw ST3*12	2
104	BVAO021104	Carbon brush	2
105	BVAO021105	Carbon brush holder	2
106	BVAO021106	Housing	1
107	BVAO021107	Stator assembly	1
108	BVAO021108	Screw ST4*65	2
110	BVAO021110	Bearing 608-2RS	2
111	BVAO021111	Rotor assembly	1
112	BVAO021112	Bearing 6900-2RS	2
113	BVAO021113	Gasket Ø10.1*22*0.5	2
114	BVAO021114	Wool felt Ø8*Ø16*1.5	1
115	BVAO021115	Gear box	1
116	BVAO021116	Bearing HK0608	1
117	BVAO021117	Ring Ø10	1

118	BVAO021118	Wheel	1
119	BVAO021119	Bering ZZ-608	1
120	BVAO021120	Centre frame	1
121	BVAO021121	Screw ST4*20	2
122	BVAO021122	Screw M4*20	3
123	BVAO021123	Output axis	1
124	BVAO021124	Belt	1
125	BVAO021125	Centre frame cover	1
126	BVAO021126	Nut	1
127	BVAO021127	Bearing 6000-2RS	1
128	BVAO021128	Wheel	1
129	BVAO021129	Bearing 6002-2RS	1
130	BVAO021130	Gasket	2
131	BVAO021131	Axis	1
132	BVAO021132	Axis	1
41	BVAO021041	Screw ST4*20	3
133	BVAO021133	Screw ST4*18	5
42	BVAO021042	Screw ST5*25	2
200	BVAO021200	Switch assembly	1
201	BVAO021201	Trigger seat left	1
202	BVAO021202	Spring	1
203	BVAO021203	Wire connected rod	1
204	BVAO021204	Trigger seat right	1
205	BVAO021205	Screw ST4*30	2
206	BVAO021206	Switch box pressplate	1
207	BVAO021207	Switch box left	1
208	BVAO021208	Wire	1
209	BVAO021209	Pulg	1
210	BVAO021210	Cable sleeve	1
211	BVAO021211	Switch reset shrapnel	2
212	BVAO021212	Rocker switch	1
213	BVAO021213	Spring	1
214	BVAO021214	Trigger	1
216	BVAO021216	Switch button	1
217	BVAO021217	Switch box	1
218	BVAO021218	Upper handle	1
219	BVAO021219	Sponge tube	1
220	BVAO021220	Wire trigger	1
41	BVAO021041	Screw ST4*20	3

11	BVAO021011	Cable pressplate	2
133	BVAO021133	Screw ST4*18	10
400	BVAO021400	Dethatcher Assembly	1
401	BVAO021401	Claw spring fixed frame cover plate	13
402	BVAO021402	Claw spring fixing frame	11
403	BVAO021403	Pawl spring	24
404	BVAO021404	Comb blade square tube shaft	1
405	BVAO021405	Claw spring fixing frame	1
406	BVAO021406	Gasket	1
407	BVAO021407	Dustproof cover for new rake blade	1
117	BVAO021117	Ring Ø10	1
127	BVAO021127	Bearing 6000-2RS	1
408	BVAO021408	Dust cover left	1
409	BVAO021409	Gasket	1
410	BVAO021410	Connecting shaft head	1



## **WARRANTY**

### **BENCHMARK 13 AMP ELECTRIC DETHATCHER WARRANTY**

If this Benchmark tool fails due to a defect in material or workmanship within five years from the date of purchase, return it to any Home Hardware store with the original bill of sale for exchange. This warranty does not include expendable parts including but not limited to blades. This warranty covers defects in material or workmanship only. It does not cover normal wear and tear, failure due to abuse/misuse, or defects caused by careless or accidental mishandling. If this Benchmark product is used for commercial or rental purposes, this warranty does not apply.

# 13 AMP ELECTRIC DETHATCHER



5 Year Limited Warranty

**BENCHMARK**<sup>TM</sup><sub>MC</sub>

**BENCHMARK TOOLS CANADA**  
ST. JACOBS, ONTARIO N0B 2N0  
© 2022 Home Hardware Stores Limited

**CUSTOMER SERVICE/TECH SUPPORT**  
1-833-818-4111

**5150-004**

Made in China



\* This Benchmark<sup>TM</sup> product carries a five (5) year LIMITED warranty against defects in workmanship and materials. See Owner's Manual for full details.



**READ ALL INSTRUCTIONS BEFORE FIRST USE.  
KEEP THIS MANUAL FOR FUTURE REFERENCE.  
KEEP AWAY FROM CHILDREN.**



**WEAR CSA APPROVED  
EYE PROTECTION**



**WEAR EAR  
PROTECTION**



**WEAR A  
FACE MASK**