

**RV170-S/RV170-SPro/RV170-S2**

**Gasoline Engine  
(Vertical Shaft)  
Owner's Manual**

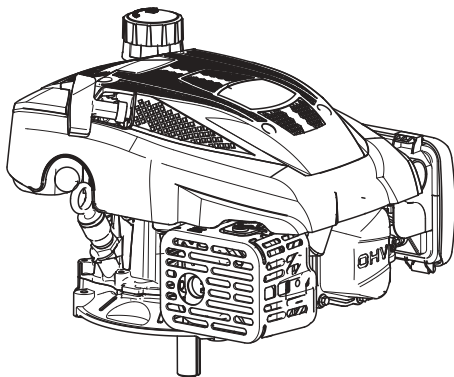



## **PREFACE**

Thank you for choosing a small general gasoline engine of our company.

The manual gives information with respect to operation and maintenance of the RV170-S/RV170-SPro/RV170-S2 general gasoline engine, and be sure to read it carefully first before operation. Only operate as the manual tells, can insure user's safety and get the best results of the engine operation. If a problem should arise or if you have any questions about your gasoline engine, consult an authorized our company servicing dealer.

The vertical shaft gasoline engine products in this Owner's Manual are mainly used for the lawn mower and mini tiller.

All information and diagrams of this manual are in accordance with the newest products at the publishing time. If revision and other change of the information described in this manual are a little different from the actual status, our company will explain it. Our company reserves the right to make change at any time without notice and without incurring any obligation. No part of this publication may be reproduced without written permission.

This manual should be considered a permanent part of the generator and should remain with the generator if resold.

## **SAFETY MESSAGES**

Your safety and the safety of others are very important. We have provided important safety messages in this manual and on the gasoline engine. Please read these messages carefully.

A safety message alerts you to potential hazards that could hurt you or others. Each safety message is preceded by a safety alert symbol  and one of three words: DANGER, WARNING, or CAUTION. These mean:



**You WILL be KILLED or SERIOUSLY HURT if you don't follow instructions.**



**You CAN be HURT if you don't follow instructions.**



**Your gasoline engine or other property could be damaged if you don't follow instructions.**

---

## CONTENTS

PREFACE .....	1
SAFETY MESSAGES .....	2
I. SAFETY PRECAUTIONS .....	4
II. PARTS DESCRIPTION .....	6
III. PRE-OPERATE INSPECTION .....	8
IV. STARTING THE ENGINE .....	13
V. STOPPING THE ENGINE.....	14
VI. EXHAUST CONTROL SYSTEM SERVICE .....	15
VII. MAINTENANCE.....	17
VIII. TRANSPORT AND STORAGE .....	21
IX. TROUBLESHOOTING .....	22
X. SPECIFICATIONS.....	26
XI. ELECTRIC DIAGRAM .....	27
XII. EASY WORN PARTS AND ACCESSORIES LIST .....	28

## I. SAFETY PRECAUTIONS



**Indicate a possibility of invalid warranty and personal or equipment damage if instructions are not followed.**

Please pay special attention to the following:

1. Strictly set the engine according to the regulated power on the owner's manual. Do not overload, overrun the engine or run it with low load and at low speed in a long time.
2. Use specified grade of gasoline. The fuel should be fully deposited and filtrated before use. Keep clean the fuel filler, change the oil periodically.
3. Periodically check the installation, connection and the degree of tightness of the fixed bolt. Tighten it if necessary.
4. Periodically clean the element of the air cleaner, change it when necessary.
5. The engine is air-cooled, so clean the radiator, wind cover and fan in time in order to make the engine cool normally.
6. The operator should be familiar with the working principle and structure of the gasoline engine, knowing how to make an emergent stop and the operation of all controlling parts. Any one without training is forbidden to operate the engine. Keep periodical maintenance. Solve problems in time. Do not run the engine in spite of malfunction.
7. Running the engine in a well-ventilated place, keep it at least one meter away from building walls or other equipments, keep away from inflammables such as gasoline, matches and so on to avoid possibility of fire.
8. Refuel in a well-ventilated area with the engine stopped, and in places

- refueling or storing gasoline, no smoking and any flames or sparks.
9. Refuel the fuel tank not too full so as to avoid fuel's spilling out. If there is spilled fuel around, be sure to clean it thoroughly before starting.
  10. Do not run the engine in airtight or ill-ventilated places.
  11. The exhaust muffler is very hot during running the engine even after the engine stops. Never touch it, or you may get burns. Transport or store the engine with it cooling down entirely.
  12. Inclination of gasoline engine which indicates the included angle between crankcase cover and level is less than  $26^{\circ}$  during its running. If that is over  $26^{\circ}$ , oil will flow into combustion chamber and burn with white smoke, which will cause gasoline engine has lower power and higher emission.
  13. Safe warning label:

Please carefully read warning label before operating. Our company will not assume any responsibility for person hurt, or equipment damaged caused by disregarding this warning label.

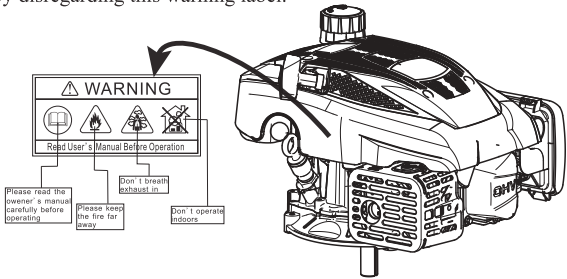

---

## II. PARTS DESCRIPTION

### 1. Feature

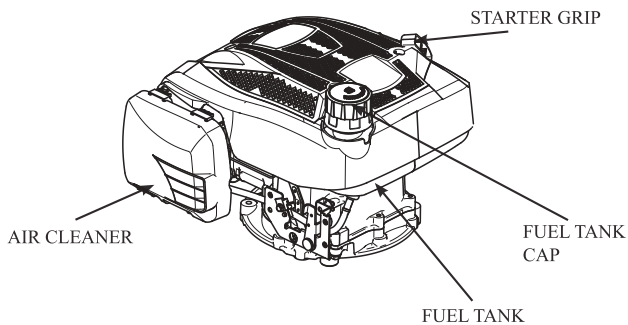
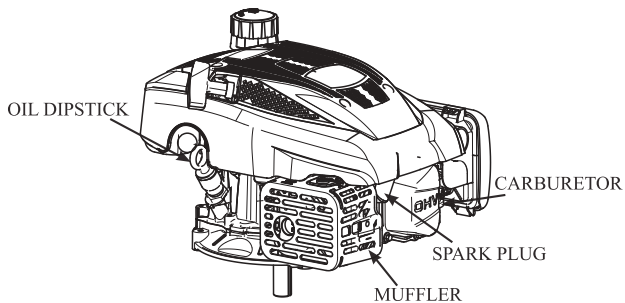

2. Model No.

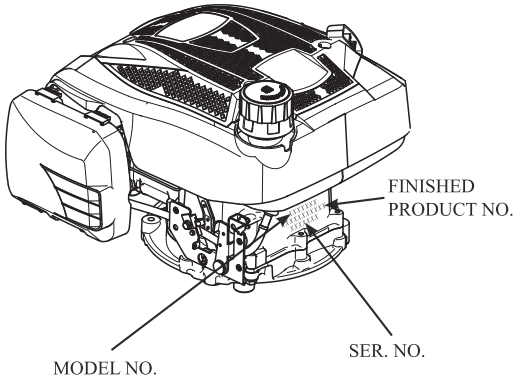

### III. PRE-OPERATE INSPECTION

#### 1. Engine Oil

Engine oil is a key factor in deciding the engine's performance. Do not apply engine oil with additives or 2-stroke gasoline engine oil, because they haven't enough lubrication, and may shorten the engines service life.

**⚠ WARNING** Check the engine with it stopped on a level ground.

**Engine oil capacity:** RV170-S/RV170-S Pro/RV170-S2 0.3L~0.5L

Engine oil recommended: SAE15W-40

As viscosity varies with regions and temperatures, SJ class oil is recommended.

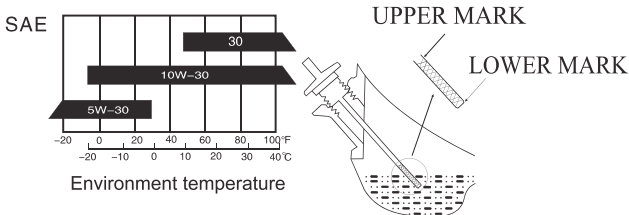

#### Check method:

- 1) Remove the dipstick and clean it.
- 2) Reinsert the dipstick into the oil Filling hole without screwing it, and check oil level.
- 3) If the oil level is too low, add the recommended engine oil up to the oil upper level.
- 4) Reinstall the dipstick.

**Engine oil change:**

Used engine oil may cause skin cancer if repeatedly left in contact with the skin for prolonged periods. It is still advisable to thoroughly wash your hands with soap and water as soon as possible after handling used oil. Please dispose of used engine oil in a manner that is compatible with the environment.

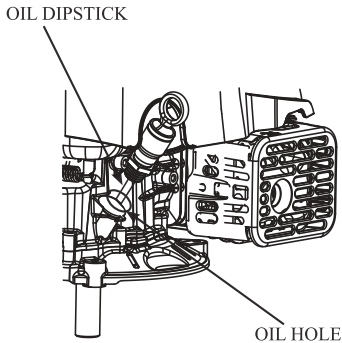

- 1) Screw the oil dipstick out.
- 2) Tilt the gasoline engine and let the oil overflowing out from the hole.

## 2. Air Cleaner



**Never run the engine without an air cleaner, or severe wear of the engine may be resulted in.**

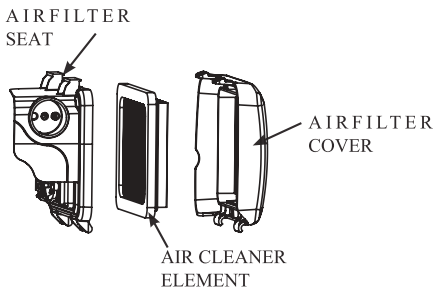

- 1) Remove the air cleaner housing.
- 2) Remove foam element or paper element, paying attention to prevent dust and foreign matter entering into air cleaner.
- 3) Check, clean or replace damaged air cleaner parts.
- 4) Reinstall the air cleaner parts back.

## 3. Fuel Check

- 1) Remove the fuel tank cap and check fuel level.
- 2) If the level is too low, refuel the tank. Remember adding fuel not over the fuel upper level.

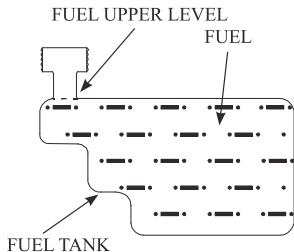

 **WARNING**

- 1. Gasoline is extremely flammable and is explosive under certain conditions.**
- 2. Refueling in a well-ventilation area with the engine stopped. Do not smoke and allow flames or sparks in the area where gasoline is stored or where the fuel tank is refueled.**
- 3. Do not overfill the fuel tank (there should be no fuel in the filling neck). After refueling, make sure the fuel tank cap is set back securely.**
- 4. Be careful not to spill fuel when refueling. Spilled fuel or fuel vapor may ignite. If any fuel is spilled, make sure the area is dry before starting the engine.**
- 5. Avoid repeated or prolonged contact with skin or breathing of fuel vapor. Keep out of reach of children.**

Fuel tank capacity:                   RV170-S/RV170-S Pro/RV170-S2:0.8L

Only use unleaded gasoline and recommend gasoline grade 90#over.

Unleaded gasoline can reduce gasoline engine carbon deposit and prolong the exhaust system service life.

Never use contaminated gasoline or mixed gasoline with oil. Don't allow the dust, foreign matter or water entering into fuel tank.

 **CAUTION**

**Fuel may damage the oil paint and plastic. Be careful not to spill fuel when refueling. Any damage due to oil spilling is not within valid warranty.**

**"Light knocking" or "spark exploding" sound can be hear when the engine overloading. It is normal. Do not worry about that.**

**If " knocking" or "spark exploding" sound occur at a steady speed under normal load, change brand of gasoline; if such phenomena still happen, consult your dealer for help, otherwise the engine may be damaged.**

**When the engine is running, continuously "Knocking" or "spark exploding" sound occurring will damage engine.**

**"Knocking" or "spark exploding" sound from misusing will not be within the valid warranty.**

## IV. STARTING THE ENGINE

### 1. Starting method:

Starting primer bulb operation is important operation of the starting engine. For cold starting, slightly press the primer bulb one to three times in succession and quickly pull the recoil cable grip. For hot starting, directly pull the starter cable grip.

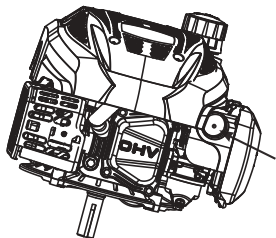

PRESS PRIMER  
BULB ONE TO  
THREE TIMES.  
THEN, PULL  
CABLE GRIP.  
START ENGINE

### 2. STARTING THE ENGINE

Pull the starter grip lightly until resistance is felt, then, briskly pull to syncline upper 30 degree out.

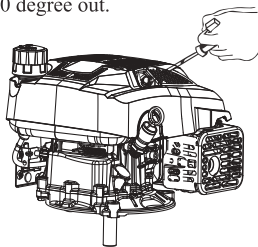

#### NOTICE

**Don't allow the starter grip to snap back against the engine. Return it gently to prevent damage to the starter**

## V. STOPPING THE ENGINE

If the engine is controlled by brake lever, only turn the brake lever to “CLOSE” position for stopping engine

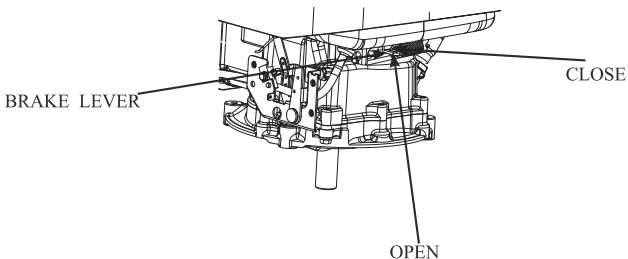

**Sudden stopping at high speed under heavy load is forbidden, otherwise damage will result.**

## **VI. EXHAUST CONTROL SYSTEM SERVICE**

With the engine running, carbon monoxide, oxide of nitrogen and hydrocarbon will produce, and in certain conditions, oxide of nitrogen and hydrocarbon will react chemically each other to make smoke while carbon monoxide is toxic, so exhaust control of them is very important. The company decreases the exhaust emissions by introducing poor-fuel carburetors and other devices into the engine to solve the problem.

To keep the exhaust of your engine with in the standard exhaust emission, pay attention to the following:

### **1. Maintenance**

Maintain the engine periodically in accordance with the maintenance schedule in the manual. The maintenance schedule is made out on the base of normal use in normal conditions, if using under heavy load, dusty or wet circumstances or in high temperature, service of the engine should be done more often.

### **2. Replacing Parts**

To ensure the best quality and reliability, use only new genuine our company parts or their equivalents for repair and replacement.

### **3. Tampering and Altering**

Tampering with or altering the emission control system may increase emissions beyond the legal limit. Among those acts that constitute tampering are:

- 1) Removal or alteration of any part of the intake, fuel, or exhaust systems.

- 2) Altering or defeating the governor linkage or speed-adjusting mechanism to cause the engine to operate outside its design parameters.

#### 4. Problems Affecting Exhaust Emissions

- 1) Difficult starting or difficult stopping.
- 2) Unstable idle speed.
- 3) Give off black smoke or consume too much fuel.
- 4) Poor ignition sparks or sparks returned.
- 5) Too early ignition.

## VII. MAINTENANCE

### 1. Maintenance Schedule

In order to keep the engine well, must periodically service and adjust the engine. Service shall be as following schedule.

#### MAINTENANCE SCHEDULE

Items \ Frequency		Every time	First month or 10 hrs of operation	Thereafter, every 3 months or 30hrs of operation	Every 6 months or 50 hrs of operation	Every year or 100 hrs of operation
Engine oil	Check-Refill	✓				
	Change		✓	✓		
Air filter element	Check	✓				
	Clean			✓		
	Change				✓	
Spark plug	Clean-adjust				✓*	
Spark arrester	Clean				✓	
Valve clearance**	Check-adjust					✓
Fuel hose	Check	Every 2 years (change if necessary)				
Cylinder head, Piston	Remove carbon deposits	Every 125 hours				

\* These items should be serviced by company authorized dealer, unless you have the proper tools and mechanically proficient.



**Service more frequently when used in dusty areas.**

## 2. Maintenance Method

### 1) Replacement of engine oil

Drain the engine oil rapidly and completely out when the engine is hot.

- (1) Remove the oil dipstick, drain plug and washer and drain engine oil thoroughly. Reinstall the drain plug and screw in it securely.
- (2) Fill the recommended engine oil and check oil level with oil dipstick.
- (3) Reinstall the oil dipstick and tighten it securely.



**Please dispose of used engine oil and the oil containers in a manner that is compatible with the environment. We suggest you take used oil in a sealed container to your local recycling center or service station for reclamation. Do not throw it in the trash or pour it on the ground or down a drain.**

### 2) Maintenance of air cleaner

A dirty or damaged air cleaner will allow dust entering into the engine, causing rapid engine wear. So, service the air cleaner in time.

- . Remove the bolt and air cleaner cover. Be careful to prevent dirt and debris from falling into the air cleaner base opening.
- . Remove the foam element or paper element.
- . Check, clean or replace the damaged air cleaner parts.
- . Reinstall the air cleaner parts, then bolt and screw down it.

**⚠ WARNING**

Never clean the air cleaner element with gasoline or low flash-point detergents, or explosion may happen.

**⚠ CAUTION**

Clean the foam filter with soapy water, blow the paper element with compressed air or lightly tap off dust and never dry to brush .

**⚠ WARNING**

- (1) Gasoline is extremely flammable and explosive in certain condition. Keep cigarette, sparks and fire away.
- (2) After reinstalling the deposit cup, don't start the engine until the area around is dry.

### 3) Maintenance of spark plug

In order to ensure the engine normal running, gap of the spark plug must be correct and no deposit around the spark plug.

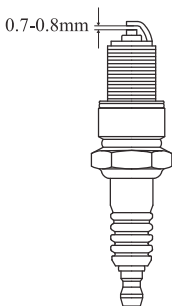

Spark recommended using plug model TORCH:  
RV170-S/RV170-S Pro/RV170-S2 :F5TC/F5RTC

**⚠ WARNING**

Don't touch the muffler to avoid burn in the engine running or just stopping a moment.

- (1) Remove the spark plug cap.
- (2) Clear away dirt around the spark plug base.
- (3) Dismantle the spark plug with a spark plug wrench.
- (4) Visually check the spark plug. Clean with a steel brush. If the insulator is damaged, replace the spark plug instead.
- (5) Measure the spark plug clearance with a feeler. The clearance should be 0.7~0.8mm. If adjustment is necessary, bend the side electrode carefully.
- (6) To avoid cross-threading, first, screw in spark plug by hand, then tighten with a spark plug wrench to compress the gasket.
- (7) If a new spark plug is used, please replace it with same spark plug model as can as possible, and more twist 1/2 turns after compressing the gasket.
- (8) If reinstalling the used spark plug, just more twist 1/8-1/4 turns.

 CAUTION

- (1) The spark plug must be tightened securely, or it may become very hot to damage the engine.**
- (2) Only use recommended spark plug or the equivalent. Incorrect heat range of the spark plug may damage the engine.**

## VIII. TRANSPORT AND STORAGE

### CAUTION

**Do not incline the engine so as to avoid fuel's spill in transporting. Spilled fuel or fuel vapor may ignite to cause fire. If suspension for a long time, storage should be as following:**

1. The storage area is dry and free of dust.
2. Completely drain fuel out of the fuel tank and carburetor.

### WARNING

**Fuel is extremely flammable and explosive under certain conditions. Keep smoke, fire and spark away from operating site.**

3. Replace engine oil.
4. Remove the spark plug. Fill about a spoon of fresh engine oil onto the cylinder. Crank the engine up to distribute engine oil evenly. Reinstall the spark plug.
5. Lightly pull the recoil starter rope until the resistance is felt. Close the choke to protect the dust from entering in.
6. Cover the engine to protect dust entering.

## IX. TROUBLESHOOTING

### 1. Start Engine Difficultly (By using recoil starter)

TROUBLE		CAUSE		REMEDY	
Normal cylinder compression	Normal spark plug spark	Something wrong with the fuel system.	Fuel supply is not smooth or no fuel supply.	There is no enough fuel in fuel tank and fuel cock is closed.	Fill fuel, open fuel cock.
			Air vent in the fuel filler cap is clogged	Dredge air vent.	
			Fuel cock is clogged	Clean first and then dredge	
			Improper or clogged main oil flow hole.	Readjust or clean, blow to get through.	
			Needle valve is not closed properly or start hole is clogged.	Dismantle needle valve and repair, clean, blow to get through.	
			Float is damaged or sticking.	Repair float	
	Fuel supply is normal.	Fuel is too filthy or deteriorated	Replace		
		There is water in fuel.	Replace		
		Too much fuel in engine	Drain extra fuel, dry up spark plug electrodes.		
		Wrong fuel brand	Select proper fuel brand corresponding with the requirements.		
	Normal fuel supply system.	Normal high-tension line spark	Spark plug is in bad conditions	Too much carbon deposit and dirt around electrodes.	Clear away.
			Electrodes are burn damaged seriously or insulators damaged.	Replace spark plug.	
Improper electrodes gap.			Adjust to proper value.		
High-tension line no spark	Normal spark plug	High-tension line is damaged.	Replace		
		Ignition coil is damaged.	Replace		
		Magneto loses magnetism.	Replace		
		Wrong gap between ignition coil and flywheel	Adjust gap between ignition and flywheel		
		Piston ring is worn to or even over its wear limit	Replace		
Abnormal cylinder compression.	Normal fuel supply system.	High-tension coil run out Normal ignition system.	Piston ring is broken.	Replace	
			Piston ring is sticking.	Clear up carbon fouling.	
			Spark plug is not installed tighten or without a gasket.	Tighten with a gasket in.	
			Air leakage between cylinder block and cylinder head.	Check cylinder gasket, and the flatness of the surface by which cylinder block contacting with cylinder head	
				Tighten cylinder head bolts in stipulated order to stipulated torque.	
			Air leakage in the valves	Check valve. Clearance and tightness, repair if necessary.	

If still can't starting, have the engine to our authorized dealer for repairing.

**⚠ WARNING**

- **When testing the spark plug, never hold the high-voltage wire of the spark plug with wet hand.**
- **Make sure there is no spilled fuel outside the engine and that the spark plug isn't dipped with fuel.**
- **To prevent fire, keep sparks far away from the spark plug mounting hole.**

## 2. Gasoling Engine Power Output Insufficiency

TROUBLE	CAUSE		REMEDY
When increasing throttle, speed increase slow or even decrease and stop running	Fuel supply system	Air in fuel line or fuel line clogged	Exhaust air or dredge fuel line
		Main oil flow hole is not adjusted properly	Readjust
		In carburetor, needle valve hole and main oil flow hole clogged.	Clean and blow to get through
		Fuel cock is clogged up.	Clean, replace damaged part
		Too much carbon deposit in combusting chamber.	Clear away
		Too much carbon fouling in muffler and exhaust pipe.	Clear away
		Air cleaner is clogged up.	Clean air cleaner filter element
		Intake pipe is leaking	Repair or replace
	Poor compression	Piston or cylinder or piston ring is worn	Replace the worn
		Air leakage from the surface by which cylinder block contacting with cylinder head.	Replace cylinder gasket
		Too big or too small valve clearance.	Readjust
		Valve tightness is poor.	Repair

## 3. Gasoline Engine Gannot Running Unsmoothly

TROUBLE	CAUSE	REMEDY
Knocking sound	Piston, cylinder or piston ring is worn excessively.	Replace the worn
	Piston pin and piston pin hole are worn excessively.	Replace piston or piston pin
	Tie rod small head is worn excessively.	Replace tie rod
	Roller bearing for crankshaft main shaft is worn.	Replace roller bearing
Abnormal combustion	Engine is too hot	Shoot trouble
	Too much carbon deposit in combustion chamber	Clear away
	Improper gasoline brand or low gasoline quality	Replace with qualified gasoline
Spark lacking	There is water in float chamber	Clean
	improper spark plug electrodes clearance	Adjust
	Something wrong with induced coil, and so on	Check and replace damaged parts

## 4. Stop Suddenly When Running

TROUBLE	CAUSE	REMEDY	
Stop suddenly when running.	Fuel supply system	Fuel is finished	Refill fuel
		Carburetor is clogged	Check fuel line and dredge
		Float chamber is leaking	Repair
		Needle valve is sticked.	Dismantle float chamber and eliminate it
	Ignition system	Spark plug is punctured, or short-circuited by carbon deposit	Replace spark plug
		Side electrode of spark plug is dropped out	Replace spark plug
		High-tension wire is dropped out	Weld on
		Ignition coil is punctured or short-circuited	Replace ignition coil
		Parking wire is located on engine body	Find out meeting and insulate
	The other	Cylinder is seriously scored and valve dropped out	Repair or replace damaged parts

## 5. Gasoline Engine Is Overheat

TROUBLE	CAUSE	REMEDY
Gasoline engine is overheat	Oil insufficient or wrong oil ratio in the gasoline	Refill engine oil
	Exhaust pipe blocked up	Clean exhaust pipe
	Shroud leaking	Repair damaged part
	Cooling fins blocked by foreign matter	Clear cooling fins
	Connection rod deformation to make piston and cylinder bushing side wear	Replace connection rod
	Cylinder or piston or piston ring is worn to make hunting between cylinder and crankcase	Replace the worn parts
	Improper adjustment of engine governor to produce speed high.	Readjust engine governor
	Crankshaft main bearing burnt out	Replace main bearing

 CAUTION

**The gasoline engine should be kept about 80 ~ 110°C temperature around the outlet of the shroud. If the temperature is too high, it will indicate the gasoline engine overheating.**

## 6. Abnormal Noise Exist When Engine Running

TROUBLE	CAUSE	REMEDY
Beating sound	Piston, piston ring or cylinder is worn	Replace the worn part
	Connection rod or piston pin and piston pin hole are worn	Replace the worn part
	Crankshaft main neck is worn	Replace bearing
	Piston ring is broken	Replace piston ring
Metal beating sound when abnormal combustion occurs	Too much carbon deposit in combustion chamber	Clear away carbon deposit
	Improper fuel brand	Replace fuel
	Engine is overheat	Find a cause and eliminate it
The other	Improper valve clearance	Readjust valve clearance properly
	Fly wheel is not connected with crankshaft tightly	Connect tightly

## X. SPECIFICATIONS

### 1. Main Specificaton

Model	RV170-S/RV170-S Pro/RV170-S2
items	
L×W×H(not including crankshaft output terminal)(mm)	365×330×245
Dry Weight(kg)	8.8
Engine Type	single cylinder horizontal,4-stroke, (OHV)
Displacement(ml)	170.1
Bore × Stroke(mm)	70×44.2
Theoretical Maximum Power	3.0kw/3600r/min
Maximum Torque	9.0N•m/2500r/min
Min Fuel Consumption	420 g/kw•h
Cooling System	Forced air
Ignition System	capacitance discharge type
PTO Shaft Rotation	vertical shaft output

### Data Adjustment

Items	Technical data	Service
Spark plug clearance	0.7-0.8mm	To see P19
Valve clearance (cold engine)	intake: 0.05~0.1mm exhaust: 0.05~0.1mm	Serviced by our company authorized dealer



**Specification is subject to change without notice. For further information, please contact our company dealer.**

### 2. Torque Of Important Bolts

Items	Specifications	Torque valve	
		N · m	kg · m
Connection-rod bolt	M5×26	8	0.8
Flywheel nut	M14×1.5	60	6.0
Crankcase cover bolt	M6×30	10	1.0
Valve clearance adjusting nut	M5	7	0.7

# XI. ELECTRIC DIAGRAM

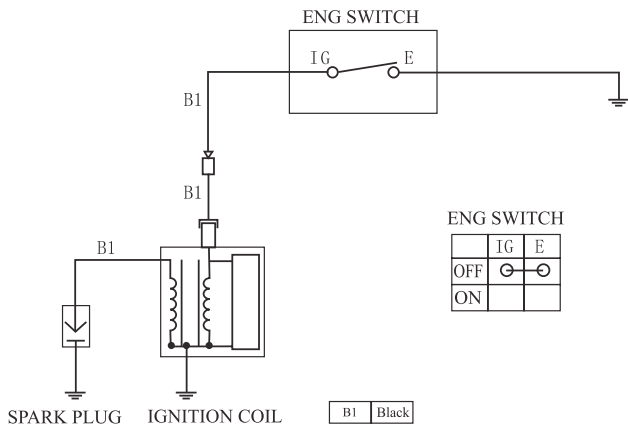

**XII. EASY WORN PARTS AND ACCESSORIES LIST**

Easy worn parts list:

Cylinder head cover gasket
Cylinder head gasket
Spark plug
Oil sealing
Breath groove gasket
Recoil starter
Carburetor gasket
Carburetor insulation gasket
Insulation plate gasket
Exhaust vent gasket

Accessories list :

Socket
Force bar

## SAFETY PRECAUTIONS:

1. Engine alone or assembled on the ultimate machine, when it tilts towards the air filter, the angle should not be beyond  $26^{\circ}$ , or oil would enter the air filter, which affects operation (engine tilts towards the muffler, the angle should be within  $90^{\circ}$ ; towards the cylinder head, the angle should be within  $26^{\circ}$ ).

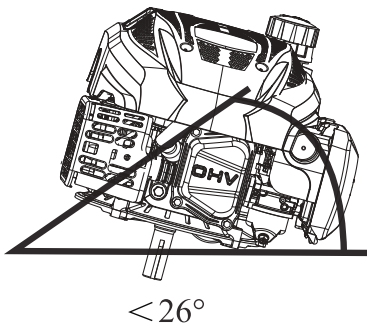

2. Engine alone or assembled on ultimate machine, the angle it tilting backwards should not be beyond  $70^{\circ}$ , or it would accelerate gasoline leakage and affect operation.

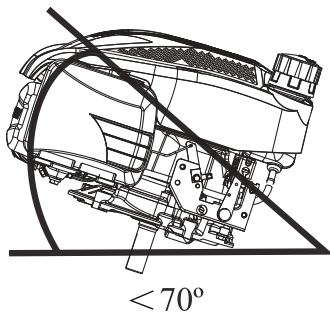

3. As power for tillers, this engine can only be used for tillers using in garden tilling.









