

BENCHMARK™

5124-044, 5124-042, 5124-041

HH0403, BM1740, BLM2050E



MANUAL



This product is supported by **Midland Power**. Contact us directly for assistance and warranty help. Do not return this product to store.

You must register online for your warranty to be valid. It only takes a minute, do it now while you still have your purchase receipt.

Register Your Product Online

[www.benchmark.midlandpowerinc.com/
register-warranty](http://www.benchmark.midlandpowerinc.com/register-warranty)



Support for your product is available online, including parts, service center locations, and live expert advice.

Visit us online at

www.benchmark.midlandpowerinc.com



Or call us anytime at **1-877-528-3772**.

Thanks for choosing Benchmark!

You're excited to get started, we'll keep this brief.

READ THIS ENTIRE GUIDE BEFORE USING THIS PRODUCT AND SAVE FOR LATER USE.

This user guide contains important instructions including safety, setup, operation, and maintenance that must be followed. All information in this guide is based on information available at the time of print. This guide or revised editions can be found on our website for download. No part of this publication may be reproduced without written permission.

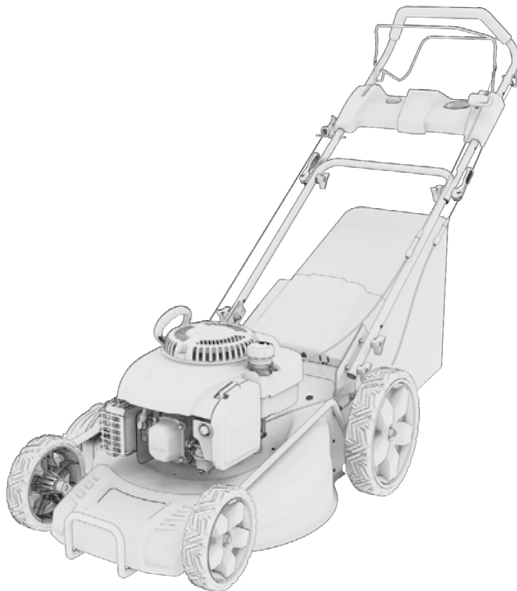

THIS PRODUCT MEETS ALL CERTIFICATION REQUIREMENTS FROM:



The engine exhaust from this product contains chemicals known to cause cancer, birth defects or other reproductive harm.





©2024 Benchmark. All Rights Reserved.

HH0403 BM1740 BLM2050E_Manual_EN_2024-02-26

TABLE OF CONTENTS

1. Safety	1
2. Learn About Your Lawn Mower	5
3. Getting Started	9
4. Pre-Operation Check	22
4.1 Check Oil Level	22
4.2 Check the Fuel Level	24
5. Starting the Engine	25
5.1 Manual Recoil Start	26
5.2 Electric Start (BLM2050E Only)	27
6. Stopping the engine	28
7. Using your lawn Mower	29
7.1. Clean Flooded Engine	29
7.2. Using the Self-propelled Function (BM1740, BLM2050E Only)	30
7.3 Emptying the Grass Bag	32
7.4 Vertical Storage	33
7.5 Mowing Tips	35
8. Maintenance	36
8.1 Maintenance Schedule	37
8.2 Changing the Engine Oil	38
8.3 Cleaning the Air-Filter	40
8.4 Replacing the Blade	42
8.5 Spark Plug Service	43
8.6 Speed Cable Adjustment	44
8.7 Fuel Filter Maintenance	44
8.8 Emission Control System	45
8.9 Carburetor Modification for High Altitude Operation	46
9. Transportation & Storage	48
10. Troubleshooting	50
11. Technical Specifications	51
12. Limited Warranty	52

1. SAFETY

⚠ DANGER	
Using an engine indoors CAN KILL YOU IN MINUTES . Engine exhaust contains carbon monoxide. This is a poison you cannot see or smell.	
 	 
NEVER use inside a home or garage, EVEN IF doors and windows are open.	Only use OUTSIDE and far away from windows, doors, and vents.
Avoid other engine hazards. READ MANUAL BEFORE USE.	

⚠ DANGER! ⚠

Using a engine indoors can kill you in minutes.

The engine exhaust from this product contains chemicals known to cause cancer, birth defects or other reproductive harm.

1.1 OPERATOR SAFETY

⚠ WARNING!

- Always perform an oil, fuel and air filter check before starting the engine.
- Properly clean and maintain the equipment.
- Operate the lawn mower according to instructions for safe and dependable service.
- Before operating the lawn mower, read the user guide carefully. Otherwise, it may result in personal injuries or equipment damage.
- **NEVER** run the lawn mower in an enclosed area to avoid harm from exhaust emissions of a poisonous carbon monoxide gas.
- Be careful not to touch the exhaust system during operation due to risk of burns.
- Pay attention to the warning labels. The engine exhaust system will become heated during operation and remain hot immediately after the engine is stopped.
- Gasoline is a highly flammable and explosive liquid. Refuel in a well ventilated area with the engine stopped.
- Use of gasoline with an ethanol content greater than 10% can damage the engine and fuel system and will void the manufacturer's warranty.
- When refueling the lawn mower, keep it away from cigarettes, open flames, smoke and/or sparks.

- Place the lawn mower at least 3 feet away from buildings or other equipment during operation.
- Run the lawn mower on a level surface. Tilting the lawn mower may result in fuel spills.
- Know how to stop the lawn mower quickly and understand operation of all the controls. NEVER permit anyone to operate the lawn mower without proper instructions.
- Keep children, pets and machinery with rotating parts away during operation.
- DO NOT operate the lawn mower in rain or snow.
- DO NOT operate the lawn mower if damaged. Have the machine repaired before use.
- DO NOT touch the spark plug while the engine is operating or shortly after the engine has been shut down.
- Wear ear and eye protection while operating this unit.

1.2 USE SAFETY

⚠ WARNING!

- DO NOT operate the lawn mower in a confined space where dangerous carbon monoxide fumes can collect.
- Refuel outdoors only and DO NOT smoke while refueling.
- NEVER remove the cap of the fuel tank or add gas while the engine is running or when the engine is hot.
- If gas is spilled, DO NOT attempt to start the engine but move the machine away from the area of spillage and avoid creating any source of ignition until gas vapours have dissipated.
- Always visually inspect to see that the blades, blade bolts and cutter assembly are not worn or damaged. Replace worn or damaged blades and bolts in sets to preserve balance.
- Mow only in daylight or in good artificial light.
- Avoid operating the equipment in wet grass, where feasible.
- Always be sure of your footing on slopes.
- Walk, NEVER run.
- Exercise extreme caution when changing direction on slopes.
- DO NOT mow excessively steep slopes.
- Use extreme caution when reversing or pulling the lawn mower towards you.
- Stop the blade(s) if the lawn mower has to be tilted for transportation

when crossing surfaces other than grass, and when transporting the lawn mower to and from the area to be mowed.

- NEVER operate the lawn mower with defective guards, or without safety devices, for example deflectors and/or grass catchers, in place.
- DO NOT change the engine governor settings or over speed the engine.
- Disengage all blade and drive clutches before starting the engine.
- Start the engine or switch on the motor carefully according to instructions and with feet well away from the blade(s).
- DO NOT tilt the lawn mower when starting the engine or switching on the motor, except if the lawn mower has to be tilted for starting. In this case, do not tilt it more than absolutely necessary and lift only the part which is away from the operator.
- DO NOT start the engine when standing in front of the discharge chute.
- DO NOT put hands or feet near or under rotating parts. Keep clear of the discharge opening at all times.
- NEVER pick up or carry a lawn mower while the engine is running.
- Stop the engine and disconnect the spark plug wire, make sure that all moving parts have come to a complete stop and, where a key is fitted remove the key.
 - Before refueling.
 - Before clearing blockages or unclogging chute.
 - Before checking, cleaning or working on the lawn mower.
 - After striking a foreign object. Inspect the lawn mower for damage and make repairs before restarting and operating the lawn mower.
 - If lawn mower starts to vibrate abnormally, check immediately.
 - Whenever you leave the lawn mower.

1.3 MAINTENANCE SAFETY

⚠ WARNING!

- Turn off the engine before performing any maintenance. Failure to do so can cause severe personal injury or death.
- Use rubber gloves when coming into contact with engine oil.
- After any maintenance is performed, wash immediately using soap and clean water, repeated exposure to lubricant may cause skin irritation.
- DO NOT clean the filter element with flammable liquids like gasoline, an explosion may occur.
- Allow the lawn mower to cool down before performing any maintenance.

- Always stop the lawn mower before removing the oil filler cap.
- To reduce the fire hazard, keep the engine, silencer, battery compartment and gasoline storage area free of grass, leaves, or excessive grease.
- Drain the fuel tank outdoors only.
- Check the grass catcher frequently for wear or deterioration.
- Only qualified maintenance personnel with knowledge of fuels and machinery hazards should perform maintenance procedures.
- See 'Maintenance Schedule' for the recommended maintenance schedule.

1.4 OTHER SAFETY TIPS

⚠ WARNING ⚠
AVERTISSEMENT



TOXIC FUMES HAZARD. Running engines give off carbon monoxide, an odourless poisonous gas that can cause nausea, fainting, or death. Do not start engine indoors or in an enclosed area, even if the windows and doors are open.

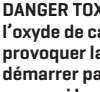

DANGER TOXIQUE. Faire fonctionner un moteur dégage de l'oxyde de carbone, un gaz inodore toxique qui peut provoquer la nausée, évanouissement ou la mort. Ne démarrer pas le moteur à l'intérieur ou dans une espace clos, meme si les fenêtres et les portes sont ouvertes.

⚠ WARNING!

- Running engines give off carbon monoxide, an odourless poisonous gas that can cause nausea, fainting, or death. DO NOT start engine indoors or in an enclosed area even if the windows and doors are open.
- If you start to feel sick, dizzy, or weak after the engine has been running, move to fresh air RIGHT AWAY. See a doctor. You could have carbon monoxide poisoning.
- Lawn mowers vibrate in normal use. During and after the use of the lawn mower, inspect the product as well as extension cords and power supply cords connected to it for damage resulting from vibration. Have damaged items repaired or replaced as necessary. DO NOT use plugs or cords that show signs of damage such as broken or cracked insulation or damaged blades.

2. LEARN ABOUT YOUR LAWN MOWER

This section will show you how to identify key parts of your lawn mower. Going over the terminology below will make sure we're on the same page.

2.1 COMPONENT IDENTIFICATION

HH0403

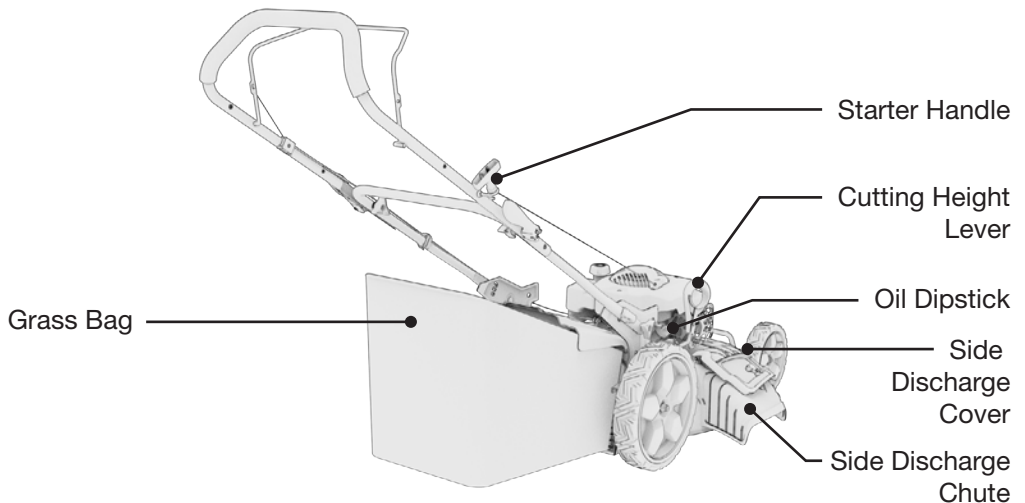
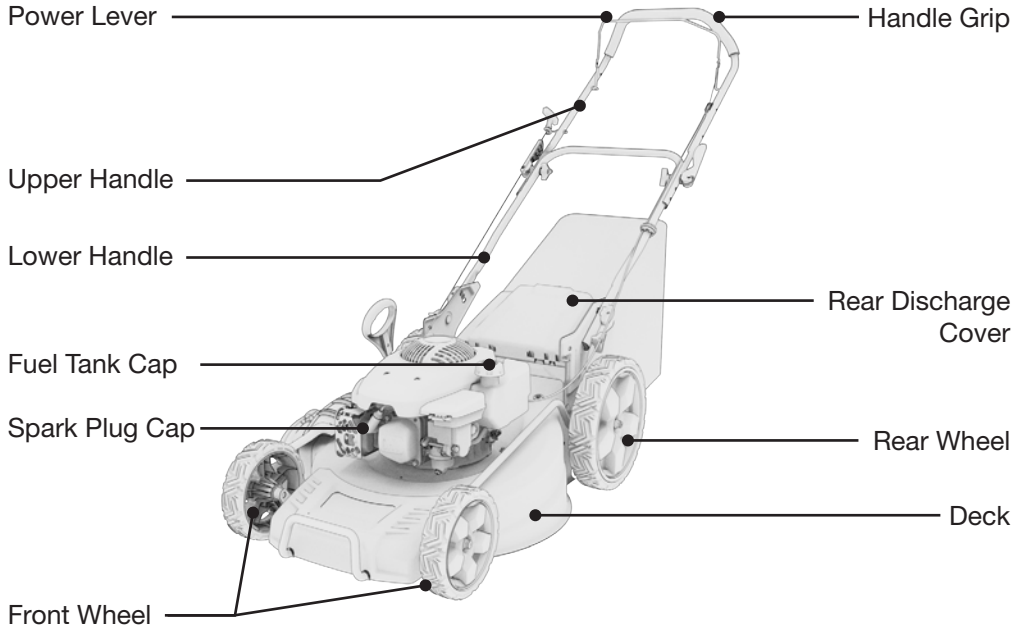

BM1740

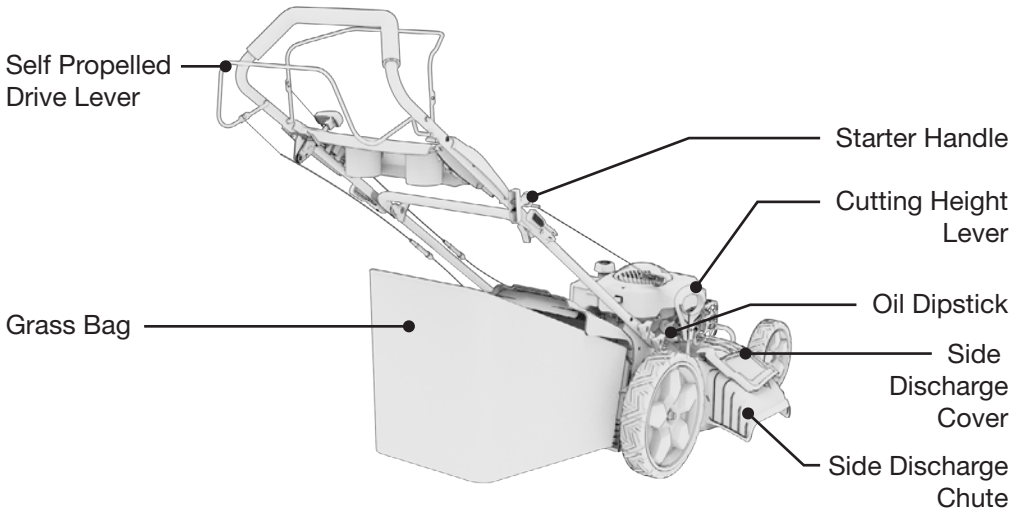
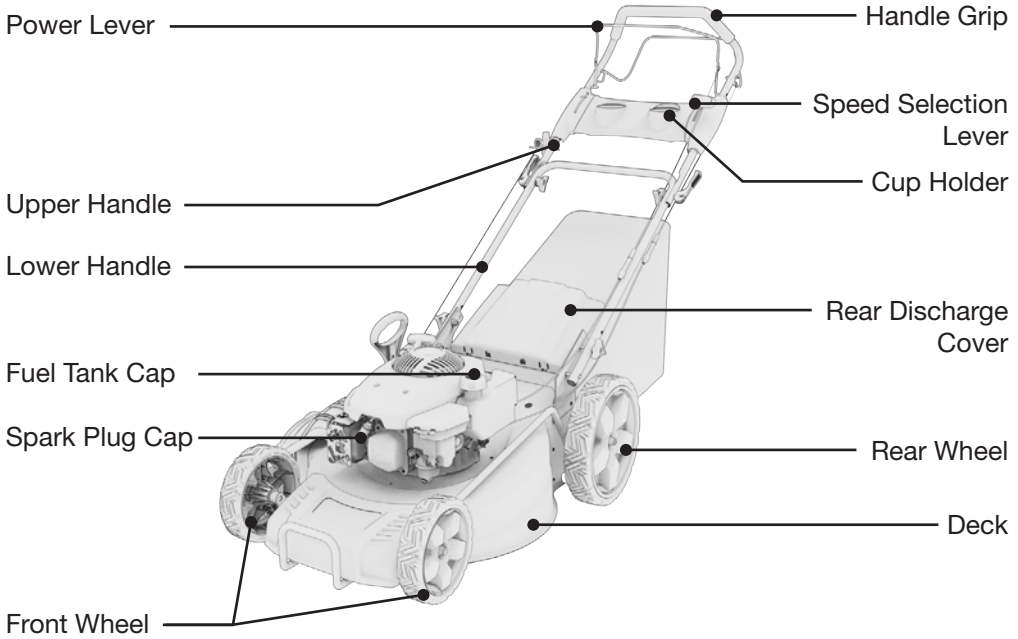

BLM2050E

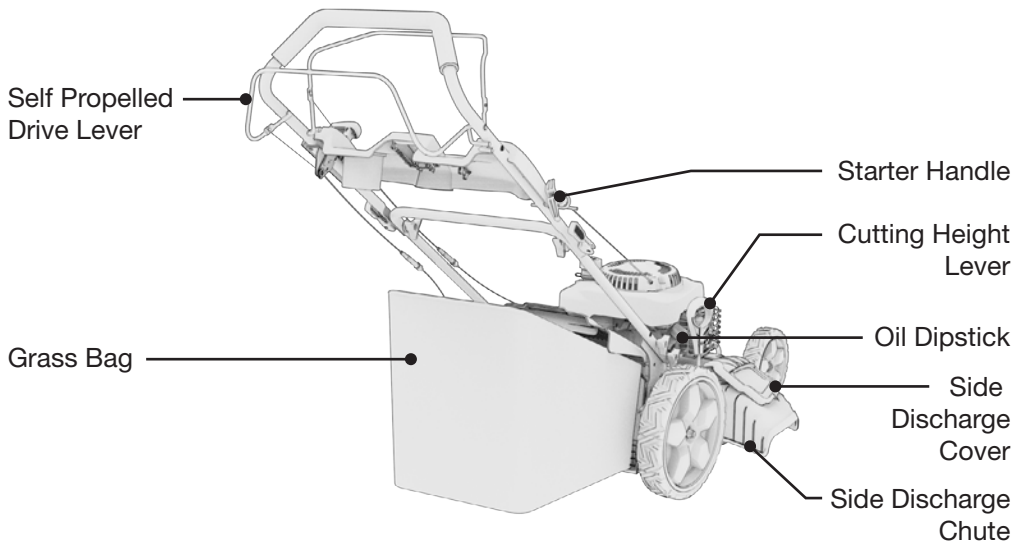
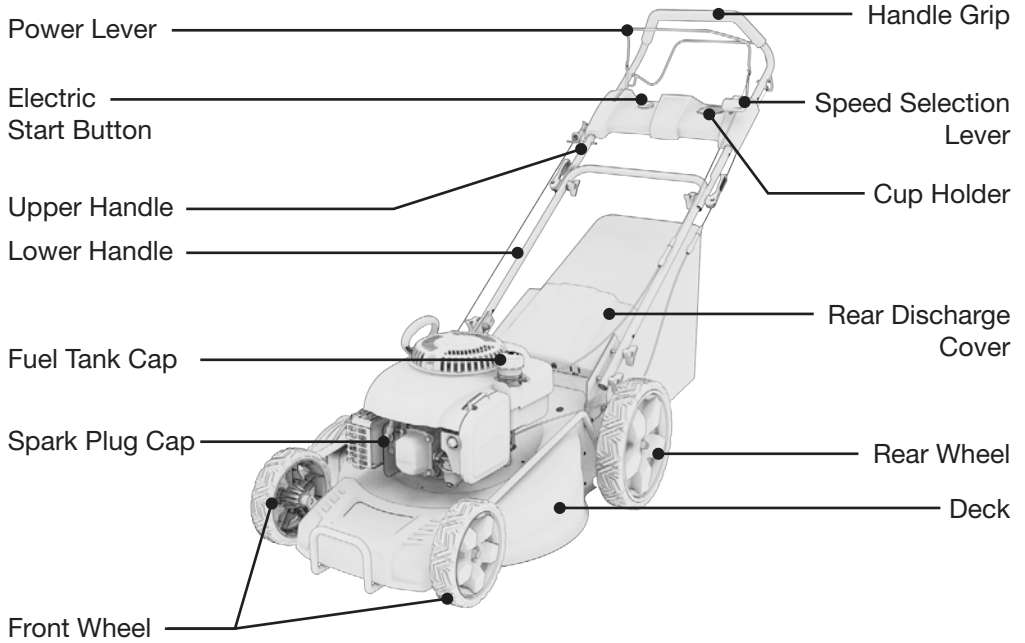

2.2 CONTROL FUNCTIONS

Cutting Height Lever

- Adjust to set the cutting height.
- The cutting height ranges from 25mm to 75mm.

Grass Bag

- When installed, the grass bag collects the grass released by the rear discharge chute.

Power Lever

- Press and hold the power lever, the engine will switch ON.
- Release the power lever and the engine will switch OFF.

Starter Handle

- For manual start, pull the starter handle while holding the power lever to the handle grip.

Electric Start Button (BLM2050E Only)

- Start the lawn mower by pressing the electric start button while holding the power lever to the handle grip.

Self Propelled Drive Lever (BM1740, BLM2050E Only)

- Press the self propelled drive lever, and the lawnmower will start to move with the engine running.
- Release the drive lever to stop.

Speed Selection Lever (BM1740, BLM2050E Only)

- Once engine is running, select drive speed 1, 2 or 3, to adjust the different propelled speed.

3. GETTING STARTED

Setup of your lawn mower is designed to get you up and running as quickly as possible. Cut the four corners of the carton from top to bottom instead of attempting to lift it out of the box.

3.1 ASSEMBLING THE HANDLE

1. On each side of handle, insert the bolt and secure with washer and handle knob.

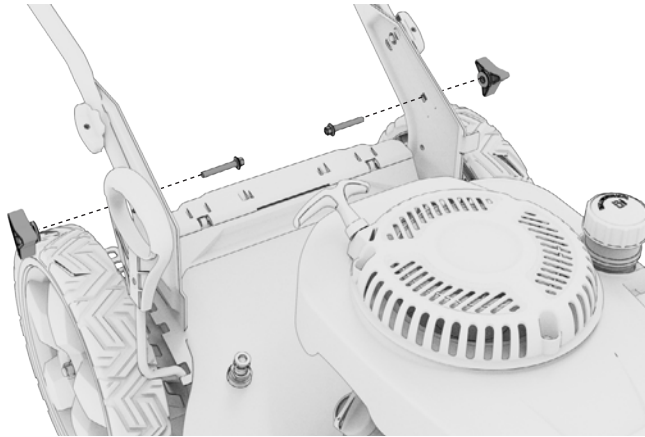

2. Turn the spring knob clockwise or counter clockwise and align the mounting holes of the bracket. Turn the knob back until the silver bolt goes through the bracket hole with the height position of your choice.

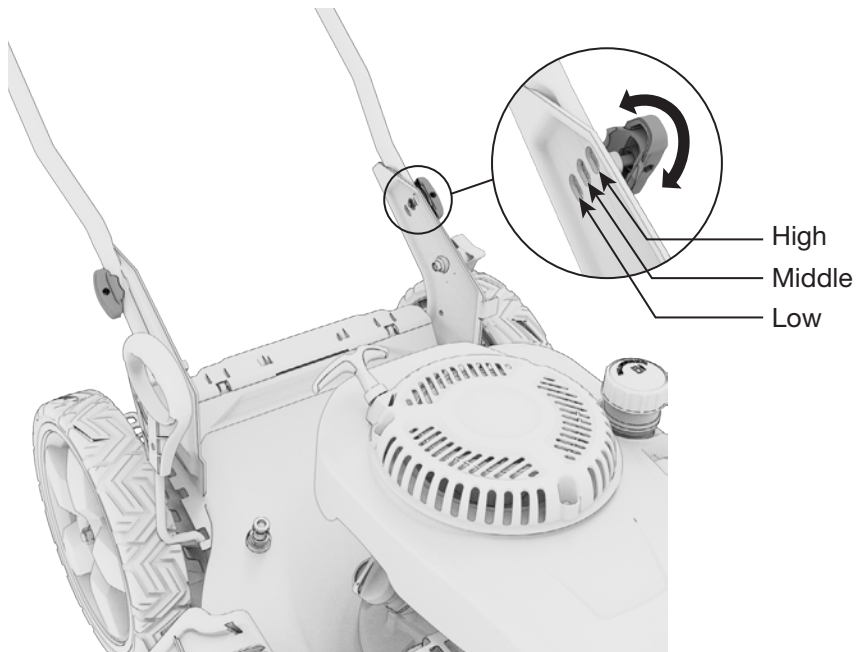

3. Unfold the upper handle and fix it to lower handle by using the big knobs and the bolts on each side.

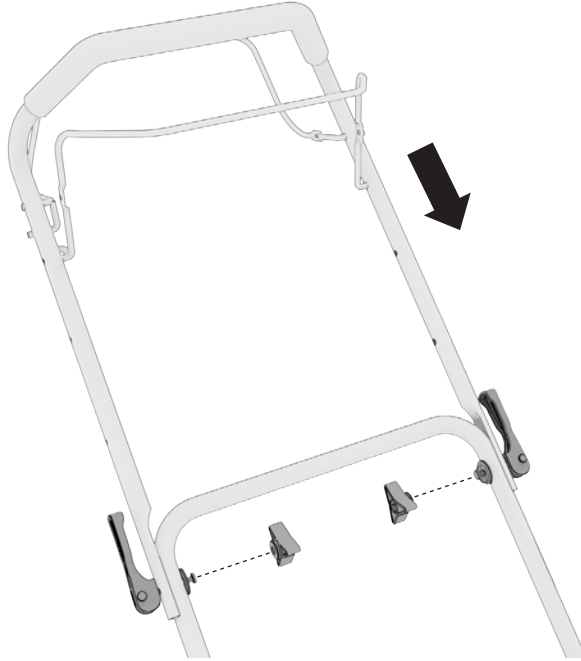

4. Ensure power lever cable is resting above lower and upper handles as pictured.

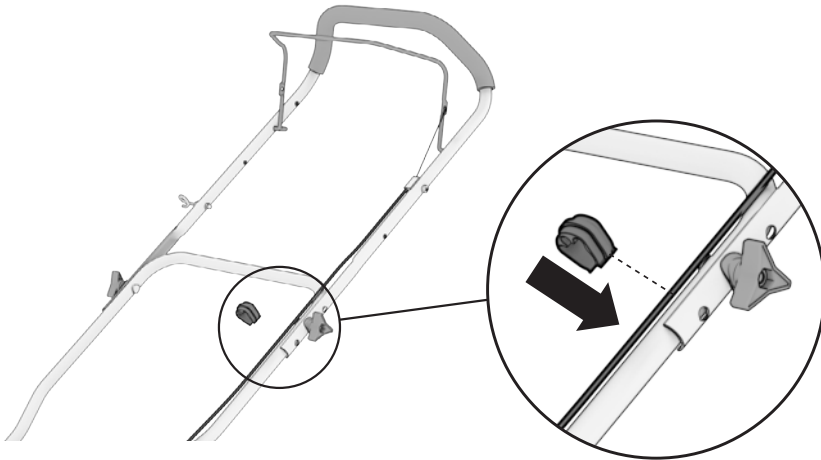

NOTE

- Make sure the rope guide is on the right handle, when you stand behind the mower.

3.2 ASSEMBLING THE RECOIL HANDLE LOOP

(Optional) Fix the recoil handle connection cord with the recoil handle loop.

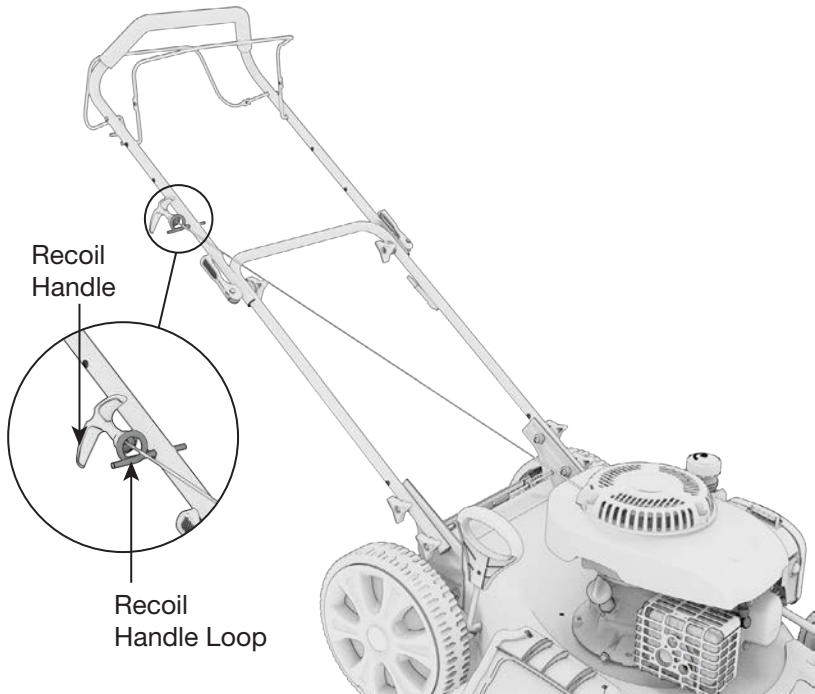

3.3 ASSEMBLING THE CUP BRACKET (BM1740, BLM2050 ONLY)

BM1740

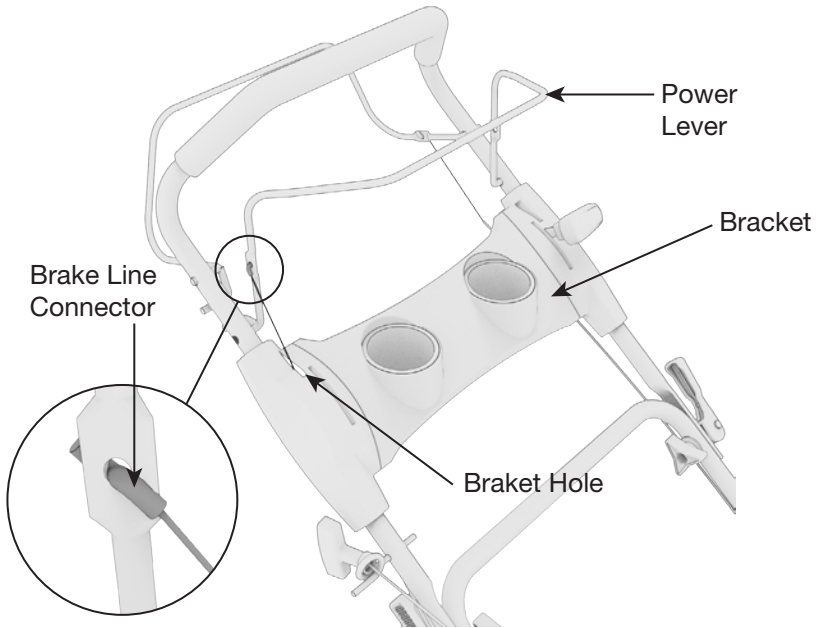

BLM2050E

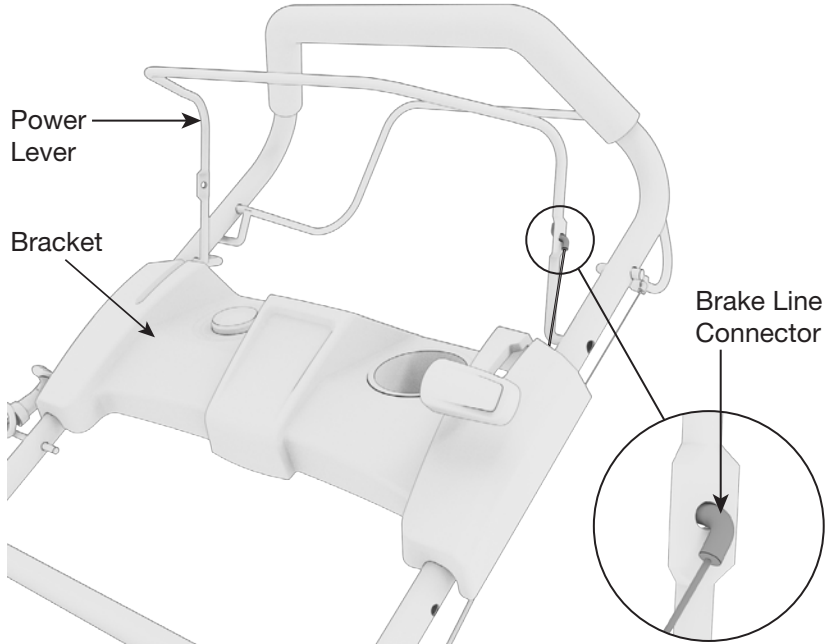

1. If already connected, remove the cable from the power lever.
2. Affix the cup bracket to the upper handle using the included screws.

3. Thread the cable through the hole in the cup bracket and connect to the power lever.

NOTE

- Only the power lever cable should go through the hole in the cup bracket.

3.4 ASSEMBLING THE SPEED SELECTION HANDLE (BM1740, BLM2050 ONLY)

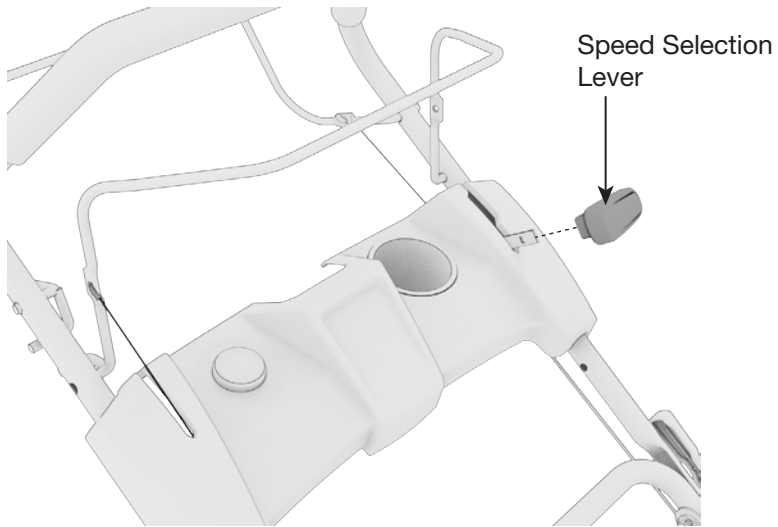

1. Put the handle onto the speed selection lever
2. Secure the handle with a screw.

3.5 REMOVE OR KEEP THE MULCHING PLUG

Keep the plug installed for mulching, or remove when choosing to side or rear discharge. If removed the plug can be stored for later use.

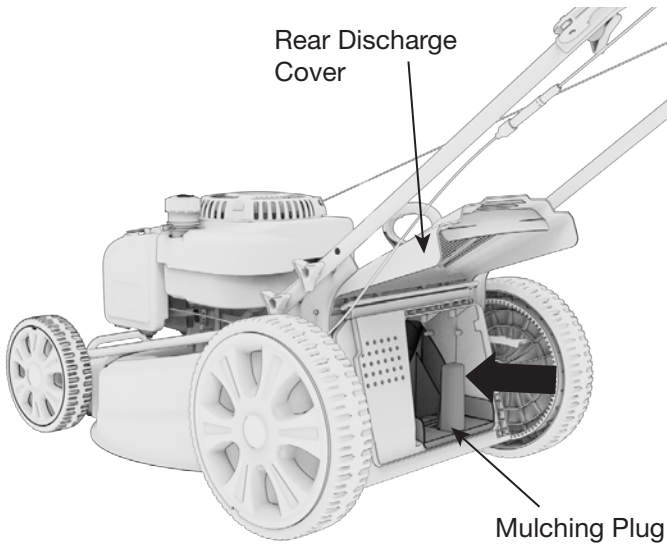

3.6 ASSEMBLING THE GRASS BAG

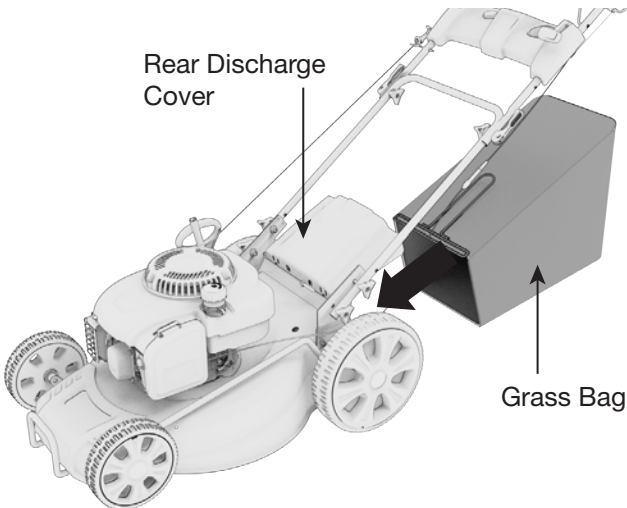

1. Clip the plastic clips of the grass bag over the metal frame and make sure they are fully secured to the metal frame.
2. Lift the rear discharge cover with one hand and hook the grass bag to the rear discharge chute. The connection may feel loose.
3. Release the rear discharge cover to secure the grass bag in position

3.7 ASSEMBLING THE SIDE DISCHARGE CHUTE

NOTE

- Remove the grass bag and assemble the mulching plug before using the side discharge function.

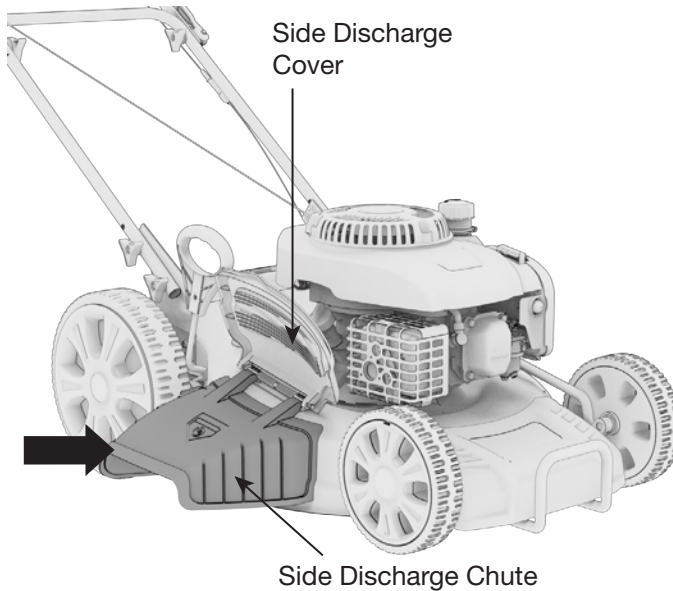

1. Lift the side discharge cover with one hand and hook in the side discharge chute with the other hand.
2. Release the side discharge cover to secure the chute in position.

3.8 ADD ENGINE OIL

⚠ WARNING!

Used motor oil can cause skin irritations if left in long-term contact with skin. Thoroughly wash off used oil as soon as possible with soap and water.

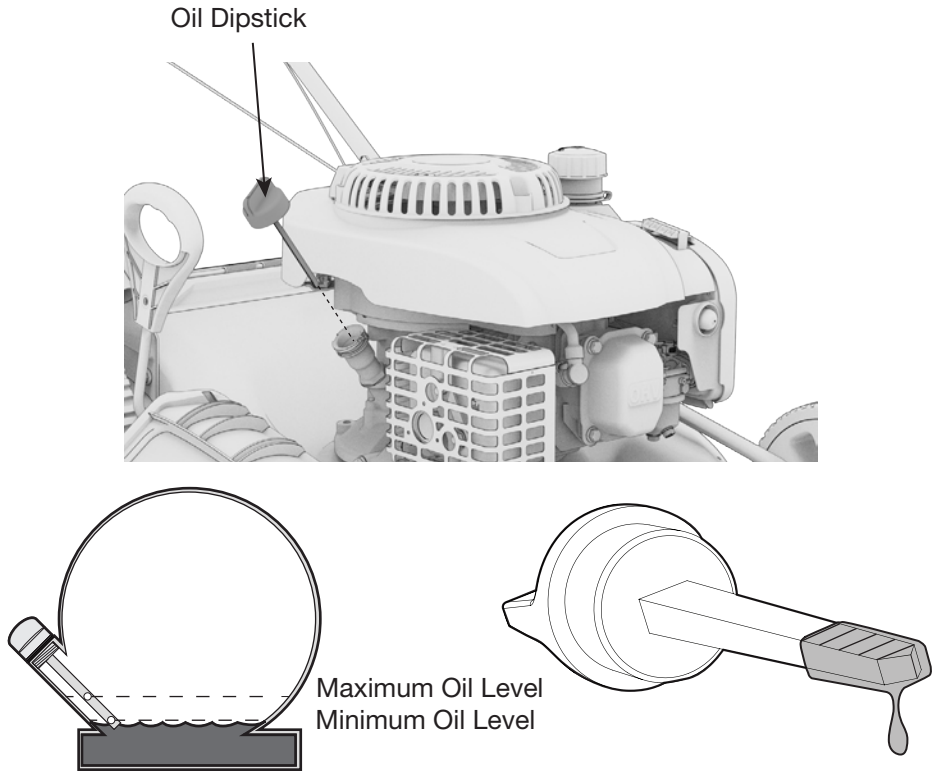

1. Ensure the lawn mower is on a level surface.
2. Unscrew and clean the dipstick.
3. Check the oil level by reinserting the oil dipstick *without* screwing it back in. Remove the dipstick and examine the oil level. If the level is at or below the minimum oil level marked on the dipstick, refill to the maximum oil level mark.
4. Reinsert the dipstick and tighten securely.

NOTE

- Oil max. capacity:
 - HH0403: 400 mL
 - BM1740: 400 mL
 - BLM2050E: 400 mL

- SAE10W-30 oil is recommended for general use.
- DO NOT OVERFILL.

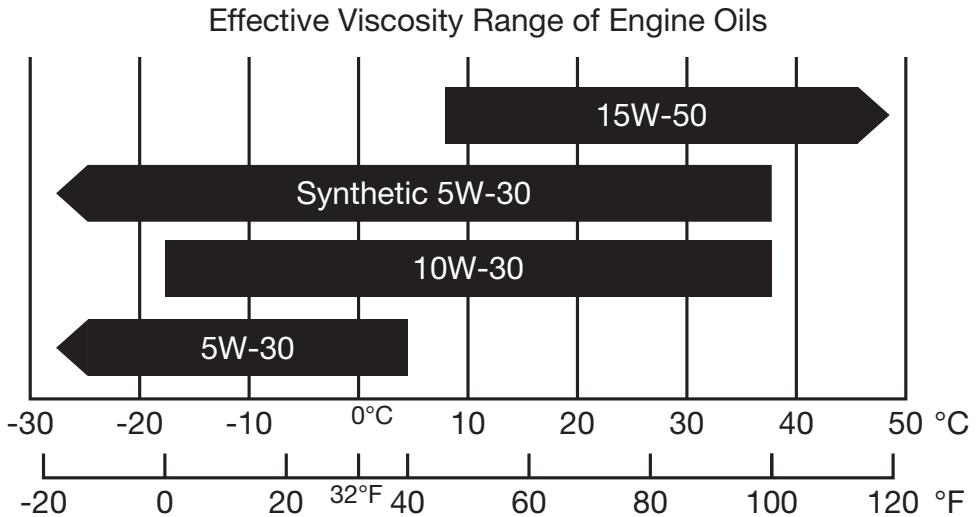

- DO NOT tilt the lawn mower when adding engine oil. This could result in overfilling and damage to the engine.
- Using non-detergent or 2-stroke oil could shorten the engine's working life.
- Use high quality engine oil with strong detergents.
- Handle and store the engine oil with care, avoid getting dirt or dust into the engine oil.
- DO NOT mix different engine oils.
- To avoid the inconvenience of unexpected engine shutoff, check the engine oil level as often as possible.
- Use 4-stroke engine oil, certified to meet or exceed API standard SG, SF, SAE ratings.

3.9 SETTING THE CUTTING HEIGHT

⚠ WARNING!

Adjust the cutting height only when the engine is switched off.

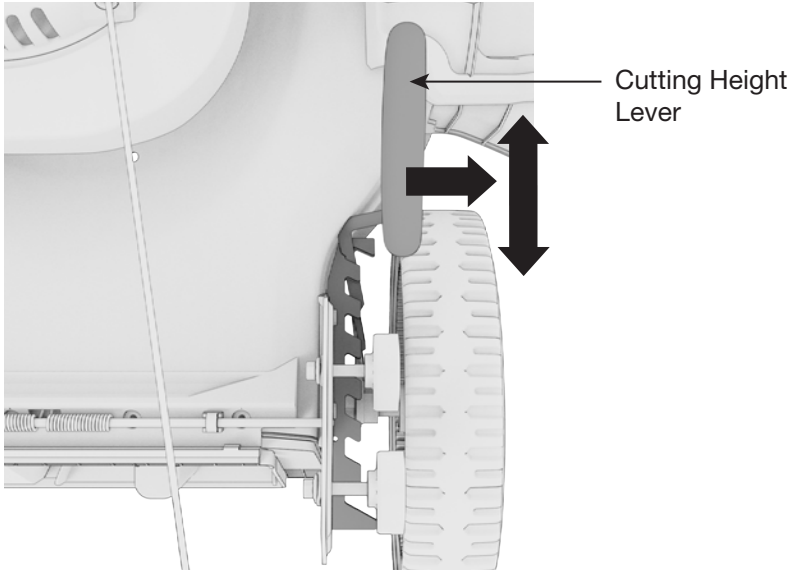

1. Pull the lever out and select the desired cutting height. The handle snaps into the desired position.

NOTE

- The cutting height ranges from 25mm to 75mm.

3.10 ELECTRIC START BATTERY (BLM2050E ONLY)

⚠ WARNING!

When using a new battery or a battery that was stored for a long time, charge the battery before using it.

DO NOT reverse polarity! Correctly connect the positive and negative polarity of the battery.

If there is abnormal noise, temperature or leakage, stop using the battery immediately. DO NOT separate, squeeze, hit, or modify the battery. The battery may overheat or catch fire. Contents of the battery are harmful to the skin and eyes, and will damage clothing. If the battery leaks, DO NOT touch the liquid, it will burn eyes and skin. If touched, immediately flush the injured area with a large amount of water and see a doctor. If the battery is hot, DO NOT touch until it has cooled down, let cool in a ventilated environment before recharging.

NOTE

- Your battery is delivered at 40% charge for safe shipping.
- The battery requires about 3 hours for a full charge.
- When the battery is not in use, remove it from the mower and store separately to maintain charge.
- Keep the battery clean and dry. If there is dirt on the surface of the battery, wipe it with a dry clean cloth.
- DO NOT store the battery in direct sunlight or other severe environments. Excessive heat will shorten service life, and may cause the battery to produce smoke or catch fire.
- DO NOT store on a metal shelf or in contact with other metal parts. If the terminals continuously contact metal the battery could overheat to a dangerous level.
- Charge the battery every three months to maintain a healthy charge. Best practice for a long service life is to store lithium-ion batteries between 40-80% charge.
- Always check if the battery is charged before using it.
- Lithium-ion battery specs: DC20V 2000mAh.

3.10.1 Charging the Battery

⚠ WARNING!

DO NOT cover the battery while charging, ensure area is well-ventilated. Covering can overheat the battery and cause damage, deformation, burns or other injuries.

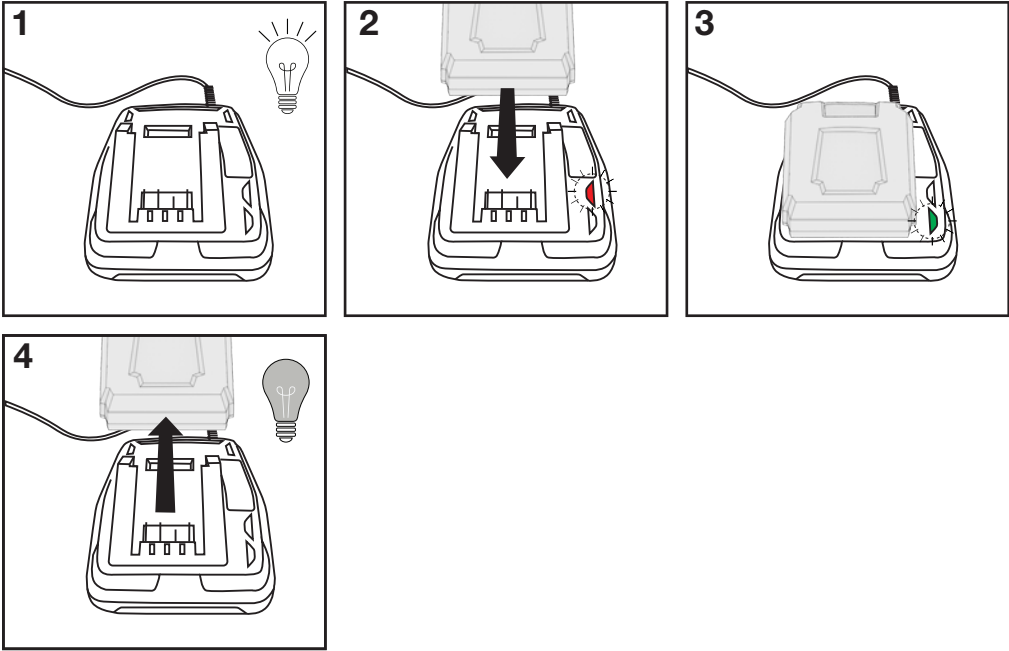

1. Plug the charger into the power socket.
2. Push the battery into the charger until it clicks, the red indicator light will illuminate to show the battery is charging.
3. When the battery is fully charged the green indicator light will illuminate.
4. When the battery is charged, remove the battery and unplug the charger from the wall.

NOTE

- Only BLM2050E has electric start battery and charger.
- Only use the supplied Lithium-ion charger.
- Ensure that the polarity is correct when charging, DO NOT attempt to charge the battery with reversed polarity.
- DO NOT store on the battery charger. Overcharging causes damage to the battery and creates a potential fire hazard.

3.10.2 Installing the Battery

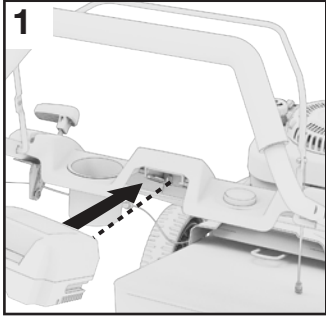

1. Insert the battery until it clicks into place securely.

3.10.3 Removing the Battery

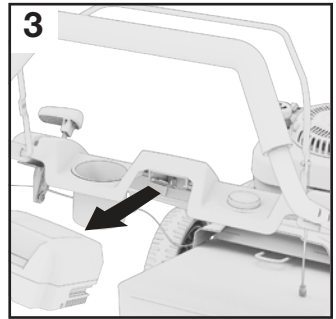
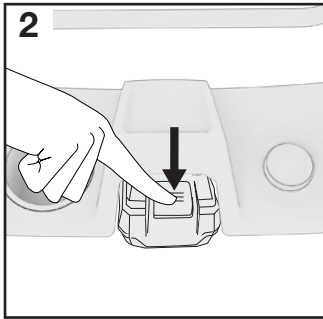
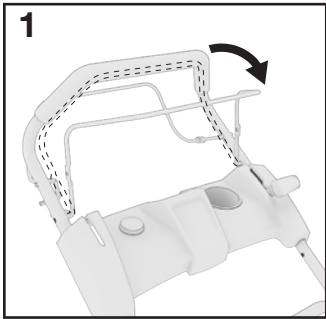

1. Ensure the handle has been released and the mower is completely stopped and cooled down.
2. Press the battery release button.
3. Slide the battery out.

4. PRE-OPERATION CHECK

These quick checks should be done each time the lawn mower is started to ensure you get the most out of your lawn mower.

Set the lawn mower on a level surface and the power to OFF.

⚠ WARNING!

Exhaust gas contains poisonous carbon monoxide. NEVER run the lawn mower in an enclosed area. Be sure to provide adequate ventilation. Operate the lawn mower on a level surface. If the lawn mower is tilted, fuel spillage may result. Keep away from rotating parts while the lawn mower is running. The lawn mower is air-cooled and may be damaged if ventilation is inadequate.

4.1 CHECK OIL LEVEL

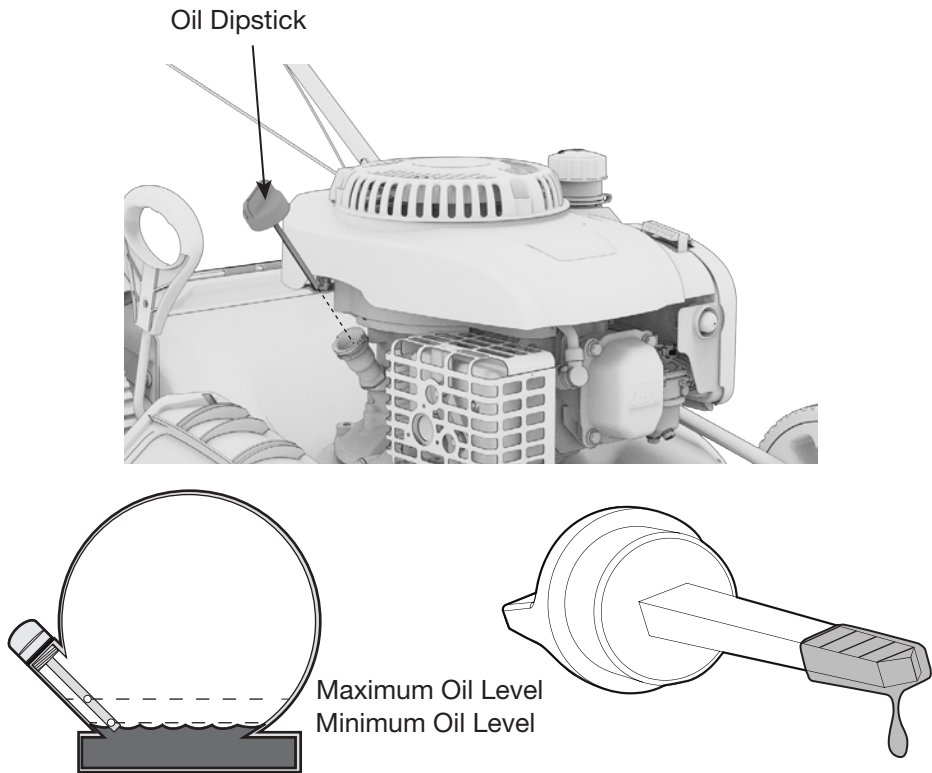

1. Ensure the lawn mower is on a level surface.
2. Unscrew and clean the dipstick.
3. Check the oil level by reinserting the oil dipstick *without* screwing it back in. Remove the dipstick and examine the oil level. If the level is at or below

the minimum oil level marked on the dipstick, refill to the maximum oil level mark.

4. Reinsert the dipstick and tighten securely.

NOTE

- Oil max. capacity:
 - HH0403: 400 mL
 - BM1740: 400 mL
 - BLM2050E: 400 mL
- SAE10W-30 oil is recommended for general use.
- DO NOT OVERFILL.

4.2 CHECK THE FUEL LEVEL

⚠ WARNING!

Gasoline is highly flammable and explosive under certain conditions. Refuel in a well-ventilated area with the engine stopped. DO NOT smoke or allow open flames or sparks in the area where the lawn mower is being refueled or where gasoline is stored. DO NOT overfill the tank. Be careful not to spill fuel when refueling. Wipe up any spilled gasoline and let the area dry before starting the engine.

Gasoline substitutes such as gasohol are not recommended. They may be harmful to the fuel system components.

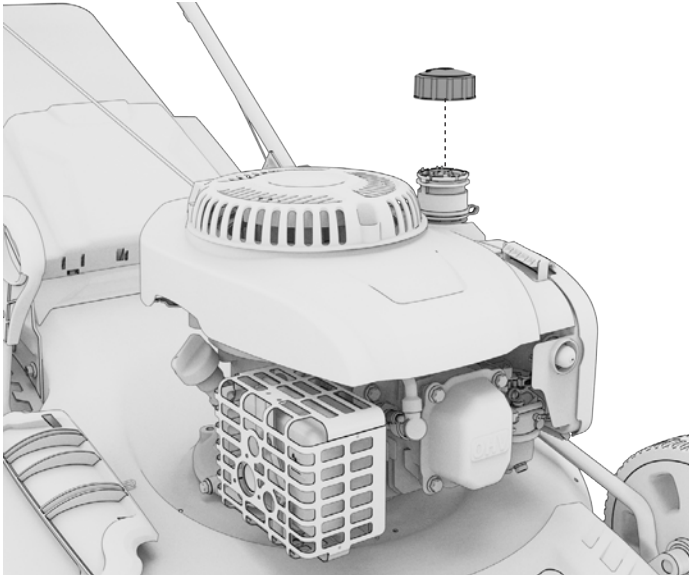





1. Check the fuel level by removing the fuel tank cap to visually check the level.
2. Add fuel carefully. DO NOT fill into the base of the fuel neck.
3. Tighten the fuel cap securely after refilling.

NOTE

- Only use unleaded gasoline (Pump Octane 87 or higher).
- NEVER use stale or contaminated gasoline, or an oil/gasoline mixture.
- Avoid getting dirt or water into the fuel tank.
- DO NOT use a mixture of gasoline containing methanol. This will cause serious damage to the engine.
- Use of gasoline with an ethanol content greater than 10% can damage the engine and fuel system and will void the manufacturer's warranty.

5. STARTING THE ENGINE

⚠ DANGER	
Using an engine indoors CAN KILL YOU IN MINUTES . Engine exhaust contains carbon monoxide. This is a poison you cannot see or smell.	
 	 
NEVER use inside a home or garage, EVEN IF doors and windows are open.	Only use OUTSIDE and far away from windows, doors, and vents.
Avoid other engine hazards. READ MANUAL BEFORE USE.	

⚠ DANGER! ⚠

Using a lawn mower indoors WILL KILL YOU IN MINUTES.

Engine exhaust contains high levels of carbon monoxide (CO), a poisonous gas you cannot see or smell. If you can smell the engine exhaust you are breathing CO. Even if you cannot smell the exhaust, you could be breathing CO.

NEVER use a lawn mower inside a home, garage, crawlspace, or other partly enclosed area, deadly levels of carbon monoxide can build up in these areas. Using a fan or opening windows and doors will **NOT** supply enough fresh air.

ONLY use a lawn mower outdoors and far away from open windows, doors, and vents. These openings can pull in lawn mower exhaust. Even when you use a lawn mower correctly, **CO** may leak into the home. **ALWAYS** use a **CO** alarm in your home.

If you start to feel sick, dizzy, or weak after the lawn mower has been running, move to fresh air RIGHT AWAY and seek medical attention. You could have carbon monoxide poisoning. NEVER run the lawn mower in an enclosed or even partially enclosed area where people may be present.

NOTE

- BM1740, BLM2050E and HH0403 DO NOT have a primer bulb included.

5.1 MANUAL RECOIL START

⚠ WARNING!

Ensure the lawn mower's blade is securely fastened before starting the engine. The blade will begin to rotate as soon as the engine is started.

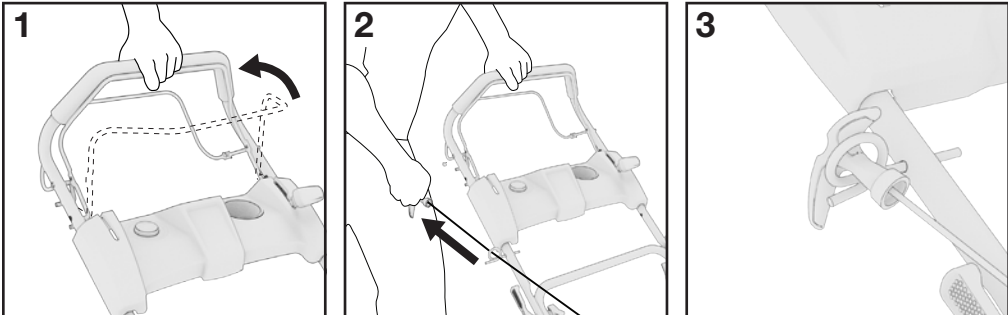

1. Stand behind the mower and pull the power lever toward the handle grip with one hand.
2. Place the other hand on the starter handle. Pull the starter handle until you feel a resistance and then start the engine with a sharp pull.
3. Slowly return the recoil handle into.

NOTE

- Return the recoil handle slowly by hand, DO NOT let it snap back.
- Before starting, ensure the spark plug cap is connected to the spark plug and the engine is filled with sufficient oil and gas.

5.2 ELECTRIC START (BLM2050E ONLY)

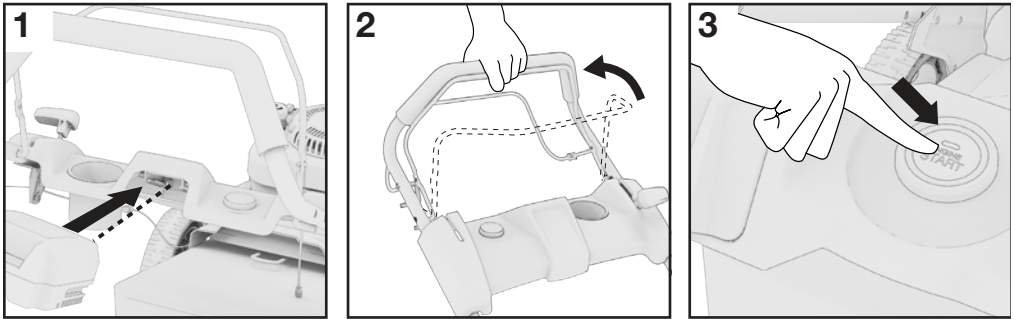

1. Insert fully charged battery.
2. Hold power lever against handle grip.
3. Hold the start button for up to 5 seconds until engine starts.

NOTE

- When using a new battery or a battery that was in storage, charge the battery before use.

6. STOPPING THE ENGINE

BM1740, HH0403

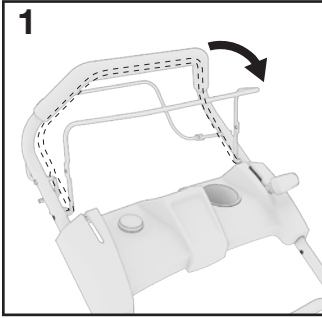

1. Release the power lever. It will return to its initial position and the engine will automatically switch off.

BLM2050E

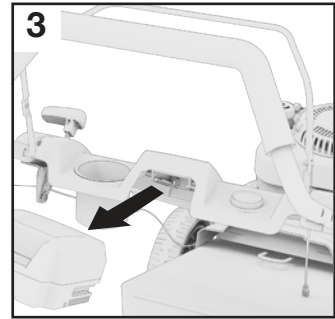
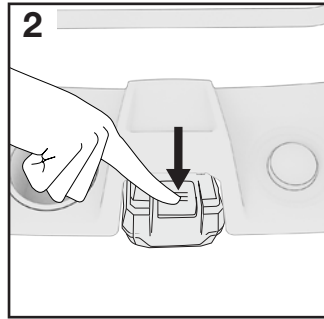
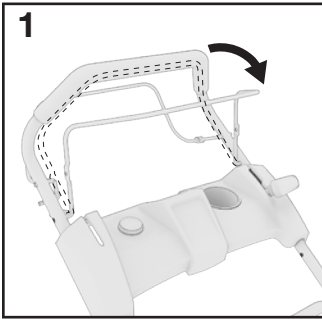

1. Release the power lever. It will return to its initial position and the engine will automatically switch off.
2. Remove the electric start battery by pressing the release button.
3. Slide out the battery and store the battery in a dry, well-ventilated area.

NOTE

- Battery may be hot, DO NOT touch the battery until it has cooled down.

7. USING YOUR LAWN MOWER

7.1. CLEAN FLOODED ENGINE

If the engine won't start after you have operated the start procedure several times, the engine may be flooded with excess fuel. Use following steps to clear and start a flooded engine.

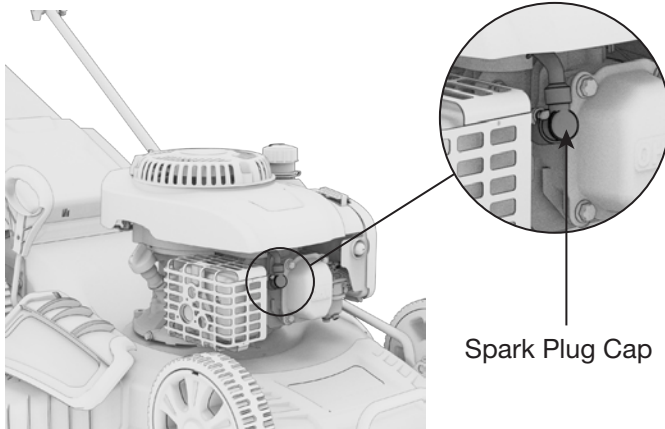

1. Release the power lever.
2. Remove the spark plug cap.
3. Remove the spark plug, dry it, and then reinstall it.
4. Operate the start procedure described on Section 5.

NOTE

- Install the spark plug carefully by hand, to avoid cross-threading. After the plug is seated tighten 1/8 to 1/4 turn with socket spanner of spark plug to compress the washer. Release the power lever.

7.2. USING THE SELF-PROPELLED FUNCTION (BM1740, BLM2050E ONLY)

The BM1740 and BLM2050E are equipped with self-propelled system. When you engage the self propelled drive lever while the engine is running, the lawn mower will begin to drive forwards.

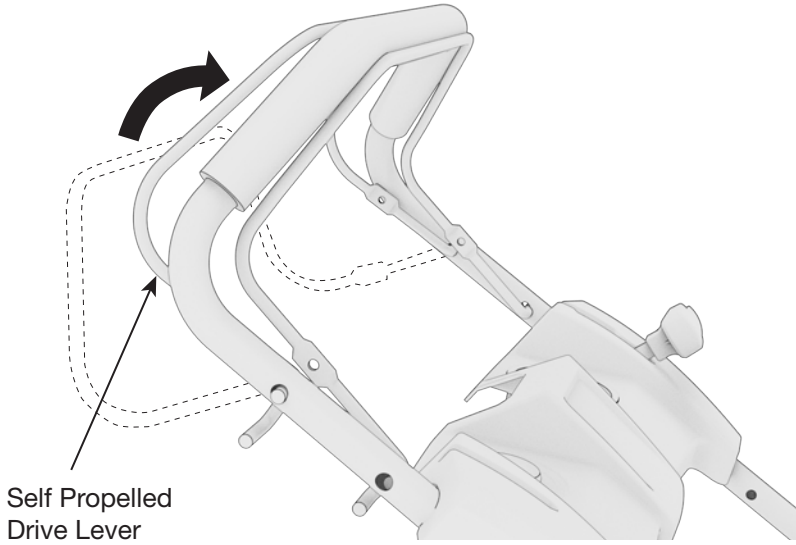

To stop moving the lawn mower, just simply release the self propelled drive lever.

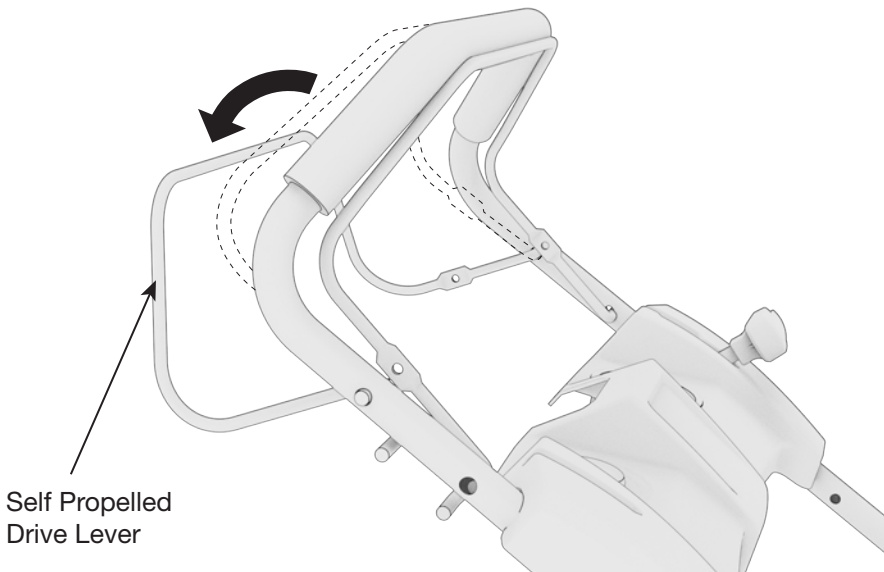

Speed Adjust

Once engine is running, select drive speed 1, 2 or 3, to adjust the different propelled speed.

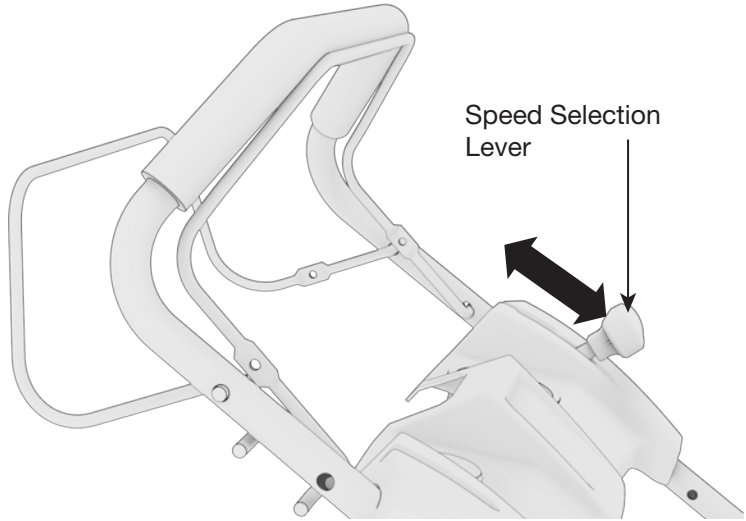

7.3 EMPTYING THE GRASS BAG

⚠ WARNING!

Before taking off the grass bag, turn off the engine and wait until the blade has come to a stop.

If any grass residue is caught in the discharge chute, clean it using a brush. DO NOT remove grass debris in the mower casing or on the blade by hand or with your feet. Instead use suitable tools such as a brush or broom. To ensure that the cut grass can be collected into grass bag, the discharge opening and inside the mower casing must be cleared of any blockage.

As soon as grass clippings start to trail the lawn mower, it is time to empty the grass bag.

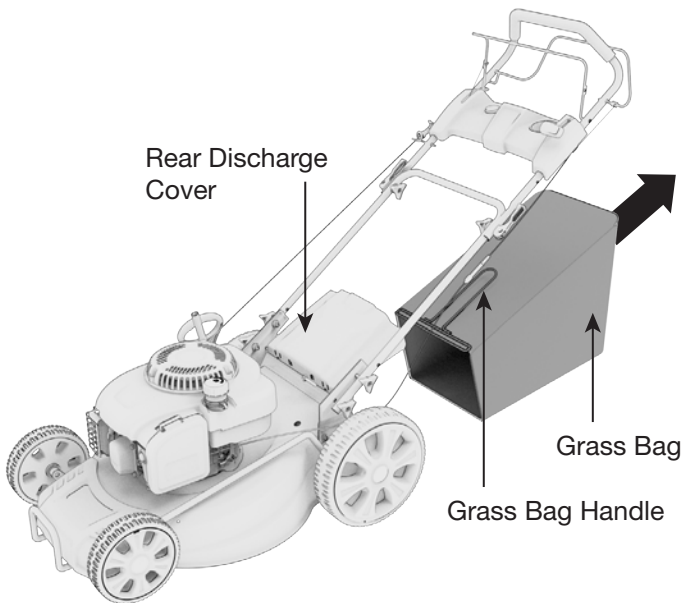

1. Use one hand to lift up rear discharge cover and the other to grab onto the grass bag handle to take off the grass bag. The rear discharge cover automatically falls down after removing the grass bag and closes off the rear chute opening.
2. Empty the grass debris in the grass bag, and reinstall the grass bag.

7.4 VERTICAL STORAGE

⚠ WARNING!

Be very careful when folding any part of handle to not pull or pinch the control cables or wires.

1. Ensure the power lever is released and the blades have stopped spinning.



2. Set cutting height lever to the lowest position.

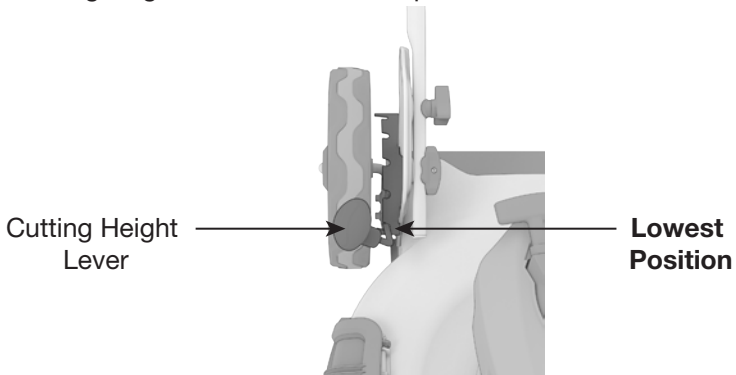

3. Release handle from upright position, fold down. Lock into vertical storage position.

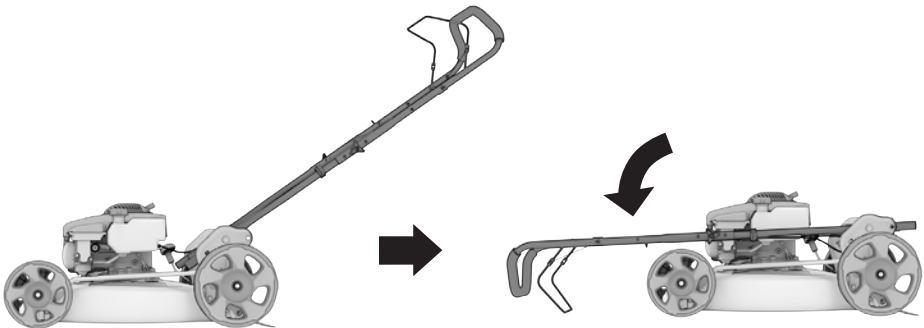

4. Tilt lawn mower upright.

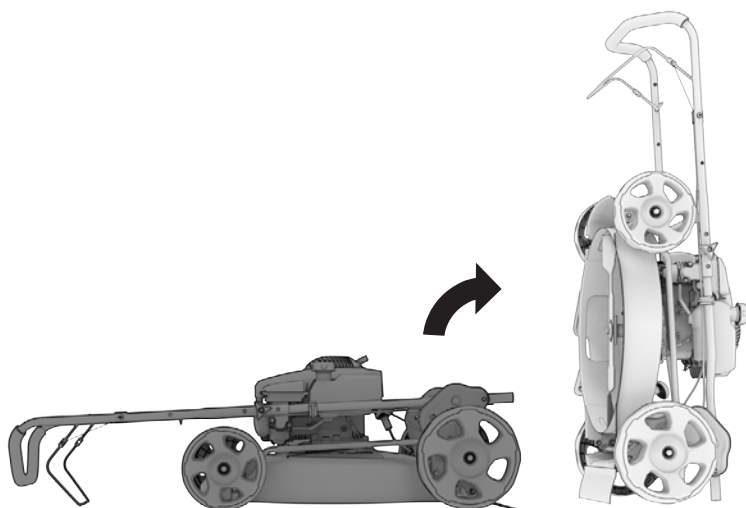

NOTE

- Read Transportation & Storage chapter if storing for over one month's time.

7.5 MOWING TIPS

NOTE

- Keep a firm grip on the upper handle with power lever and self propelled drive lever closed and walk along with it self-propelling to start mowing.
- Walk, NEVER run with the mower, be very careful when mowing uneven or rough ground.
- Mow across slopes, NEVER up and down.
- Be careful when changing the direction of the mower on a slope.
- DO NOT mow excessively steep slopes.
- The best result will be achieved if the grass is dry. Wet grass will tend to clog the blade and the grass collection system.
- Grass grows at different rates at different time of the year. NEVER use the lowest cutting height for the first cut of the season or in drought conditions.
- Only about one thirds of the grass height should be cut.
- When mowing with mulching, to ensure that the cut grass can be scattered efficiently, DO NOT cut high or wet grass. When you have been cutting for several minutes, please stop the mower, and clean the blade and the deck.
- DO NOT remove grass debris in the mower casing or on the blade by hand or with your feet. Instead use suitable tools such as a brush or broom.

8. MAINTENANCE

Proper maintenance keeps your lawn mower in the best operating condition by ensuring safe, economical and trouble-free operation. Only use genuine parts and recommended fluids to replace the worn components. Improper maintenance may cause the lawn mower to malfunction and can lead to serious injury. Contact customer support if you have any maintenance questions.

General Inspection Tips

- Look for fuel leaks around the fuel tank and repair leaks immediately.
- Look and listen for exhaust leaks while the engine is running. Have all the leaks repaired before continuing operation.
- Check for dirt and debris and clean as necessary.
- Check the engine oil level and add oil as necessary.
- Always clean your lawn mower immediately after use.
- DO NOT allow grass cuttings and other debris to become dry and hard on any of the mower surfaces. Dried grass remnants and dirt may impair the mowing operation.
- Check that the grass chute is free of any residual grass.
- Tilt the lawn mower onto its left side (opposite the oil filler neck) to check the underside of the lawn mower and the blade mount.

8.1 MAINTENANCE SCHEDULE

Maintain the lawn mower according to the maintenance schedule in this section.

NOTE

- Service more frequently when used in dusty areas.
- These items should be serviced by an authorized service center, unless you have the proper tools and are mechanically proficient. Refer to manual for service procedures.

Before Each Use
General inspection Check engine oil level Inspect air filter
First 5 Hours
Change engine oil
Every 12 Hours
Check engine oil level Check and clean air filter ¹ Inspect/clean spark plug
Every 36 Hours
Check engine oil level Replace spark plug Replace air filter Inspect/replace blades ³
Every 300 Hours
Clean combustion chamber ³ Inspect/adjust valve clearance ³ Clean fuel tank and strainer Inspect/replace blades ³

¹ Replace if it cannot be adequately cleaned.

² Change oil after every 100 hours or yearly, whichever comes first. Service more frequently when operating under heavy load or in high temperatures.

³ Recommend service to be performed by authorized service dealer.

8.2 CHANGING THE ENGINE OIL

⚠ WARNING!

Used motor oil can cause skin irritations if left in long-term contact with skin. Thoroughly wash off used oil as soon as possible with soap and water.

DO NOT dispose of used oil in drains or on soil. Local service shops provide environmentally-friendly disposal methods.

Fully drain the fuel tank using a gasoline extraction pump before placing the lawn mower on its side.

Drain the oil rapidly and completely on a level surface while the engine is still warm.

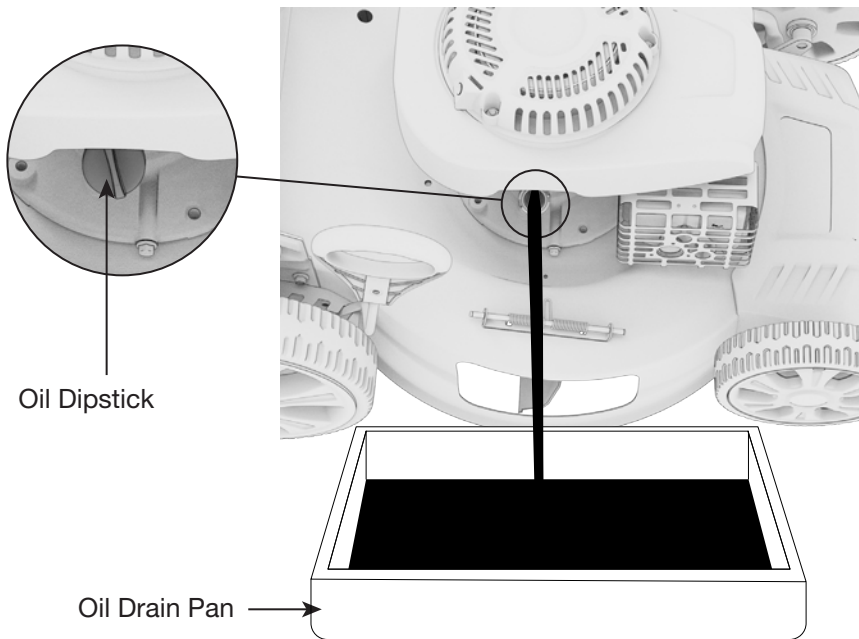

1. Tilt the lawn mower towards the oil drain pan, have a container ready to catch the oil and remove the dipstick.
2. Once the oil has been emptied, return the lawn mower to a level position and wipe clean any spillages.
3. Fill the engine with fresh oil (SAE 10W-30 4 Cycle Engine Oil) up to the maximum mark on the dipstick *without* threading it back in. DO NOT overfill oil reservoir. Use a funnel to prevent spillage.
4. Reinstall the oil dipstick and tighten.

NOTE

- Oil max. capacity:
 - HH0403: 400 mL
 - BM1740: 400 mL
 - BLM2050E: 400 mL
- SAE10W-30 oil is recommended for general use.
- DO NOT OVERFILL.

Effective Viscosity Range of Engine Oils

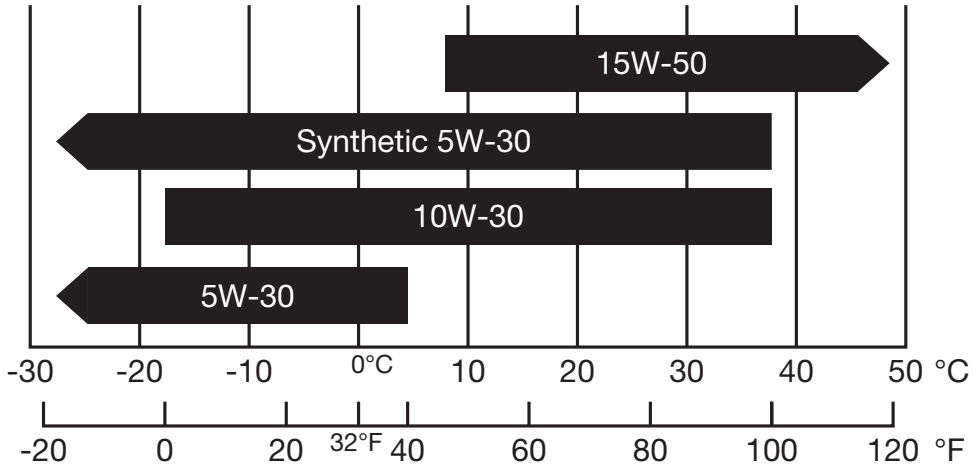

- DO NOT tilt the lawn mower when adding engine oil. This could result in overfilling and damage to the engine.
- Using non-detergent or 2-stroke oil could shorten the engine's working life.
- Use high quality engine oil with strong detergents.
- Handle and store the engine oil with care, avoid getting dirt or dust into the engine oil.
- DO NOT mix different engine oils.
- To avoid the inconvenience of unexpected engine shutoff, check the engine oil level as often as possible.
- Use 4-stroke engine oil, certified to meet or exceed API standard SG, SF, SAE ratings.

8.3 CLEANING THE AIR-FILTER

⚠ WARNING!

Using gasoline or other flammable solvents can cause fire or explosion. DO NOT operate this product without an air filter.

DO NOT use pressurized air or solvents to clean the filter. Pressurized air can damage the filter and solvents will dissolve the filter.

A dirty air filter will restrict air flow into the carburetor. Clean and maintain the air filter regularly, especially in dusty areas.

NOTE

- NEVER run the lawn mower without an air filter, doing so will quickly degrade the engine.

BM1740, HH0403

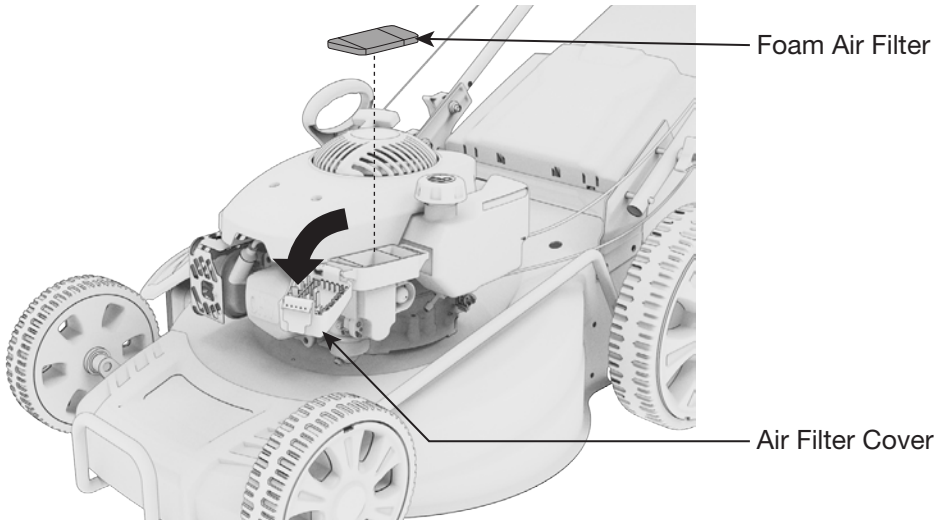

BLM2050E

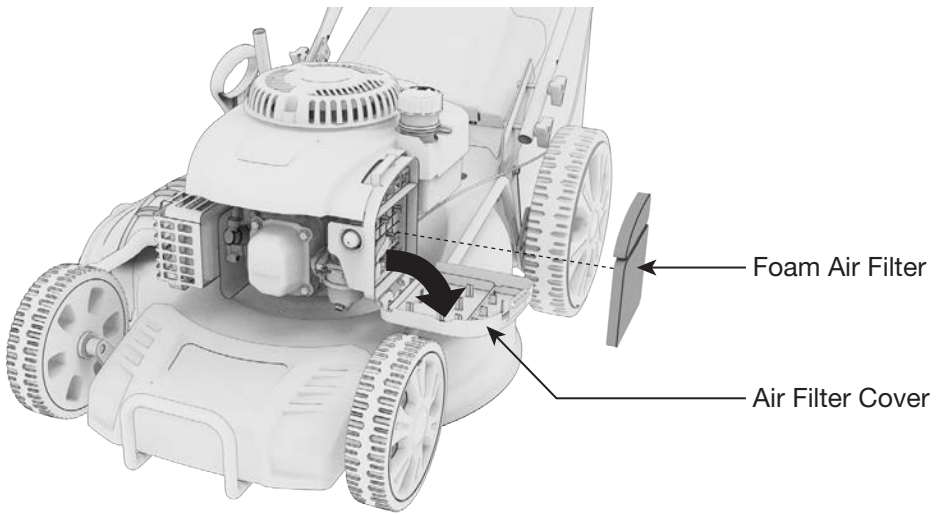

1. Loosen the nut and remove the air filter cover. Remove the air filter housing and elements and inspect for cleanliness.
2. Clean the *foam* air filter with soap and water and let dry.
3. Soak the *foam* filter in clean engine oil.
4. Gently squeeze and then pat out all excess oil and reinstall.
5. Replace filter if it is damaged.

8.4 REPLACING THE BLADE

⚠ WARNING!

Used motor oil can cause skin irritations if left in long-term contact with skin. Thoroughly wash off used oil as soon as possible with soap and water.

Always use gloves and handle the blade with care, sharp edges could cause injury. DO NOT hold the blade by hand directly. If the blade has worn excessively and become pitted and blunt, it should be replaced or sharpened. The sharpness of the blade will affect the performance of the lawn mower. Replace any cracked or damaged blade immediately.

For safety reasons we recommend that the blade only be changed by someone qualified and authorized.

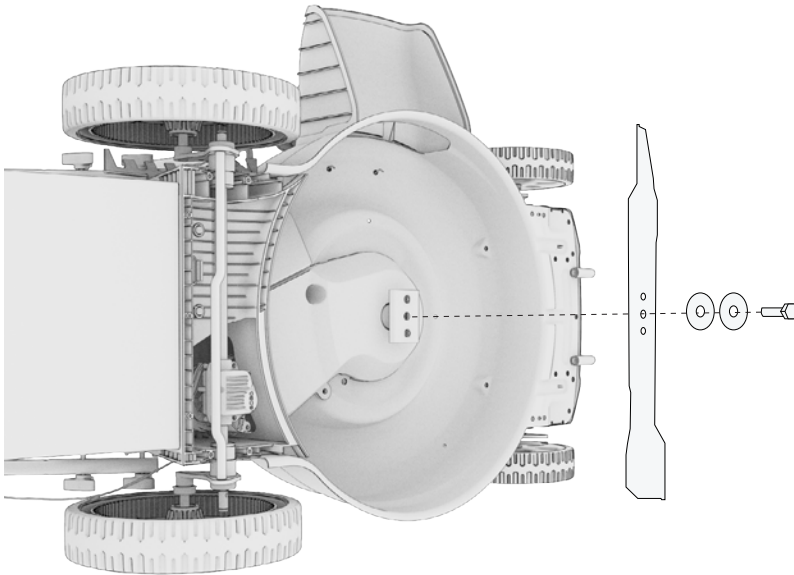

1. Stop the engine and wait until the blade stops completely.
2. Hold the blade and unscrew the blade bolt counterclockwise using a spanner wrench (not included).
3. Remove the washer and the blade.
4. Fit a new blade or re-sharpen the blade, locate the blade on the two studs on the blade flange and then replace the washer and bolts.
5. Make sure the blade is correctly located, and then firmly tighten the bolt. DO NOT over tighten. The up turn of the blade must project into the motor compartment.

8.5 SPARK PLUG SERVICE

NOTE

- DO NOT rinse spark plug in water. Follow guidelines and be careful not to overtighten the spark plug.

Recommended spark plug:

- HH0403: F6TC
- BM1740: F6TC
- BLM2050E: F7TC

Check the spark plug gap and clean the carbon deposits at the bottom of the spark plug.

Tighten 1/2 turn when installing a new spark plug.

Tighten 1/8 TO 1/4 turn when re-installing an old spark plug.

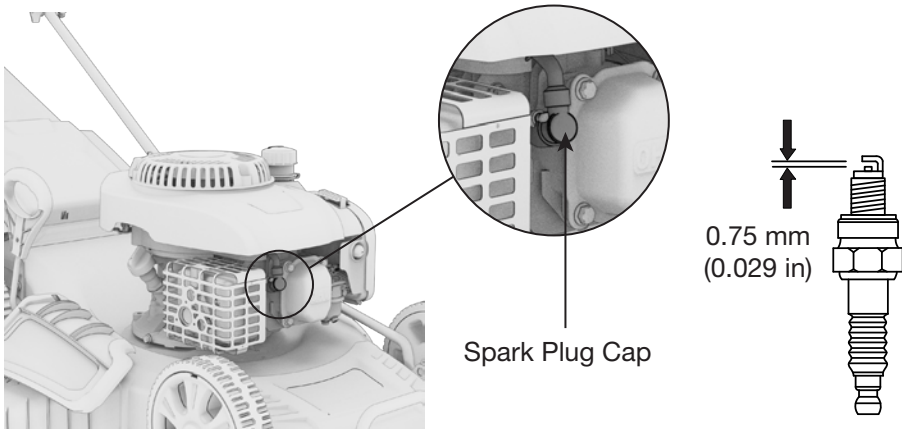

1. Remove the spark plug cap.
2. Remove the spark plug with the spark plug wrench.
3. Visually inspect the spark plug. Replace with a new plug if the insulation is cracked or chipped. Clean with a wire brush if the spark plug is reused.
4. Measure the spark plug gap with a feeler gauge. The normal value is: 0.75 mm (0.029 in). Adjust the gap by carefully bending the electrode.
5. Carefully reinstall the spark plug by hand, to avoid cross-threading. A new spark plug should be tightened 1/2 turn with a spanner. A used spark plug should be tightened 1/8 to 1/4 turn with spanner.
6. Reinstall the spark plug cap.

NOTE

- The spark plug must be securely tightened or it could cause the spark plug to heat up, enough to damage the engine.
- NEVER use a spark plug with an improper heat range.

8.6 SPEED CABLE ADJUSTMENT

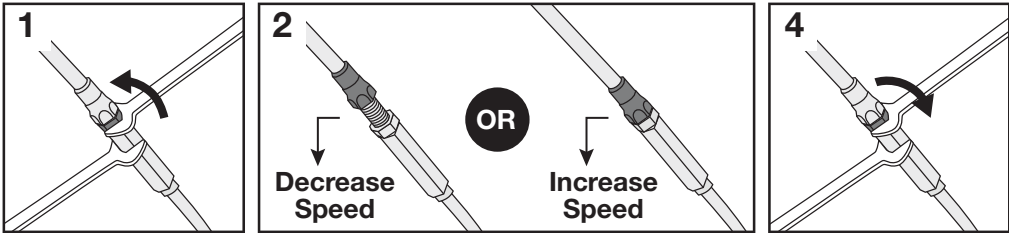

1. Loosen the center nut.
2. To decrease speed, unscrew the bolt to lengthen the cable. To increase speed, screw bolt back into the nut to shorten the cable. This will only be possible if speed has been decreased before.
3. Tighten the central nut to secure the length of the adjustment bolt.

8.7 FUEL FILTER MAINTENANCE

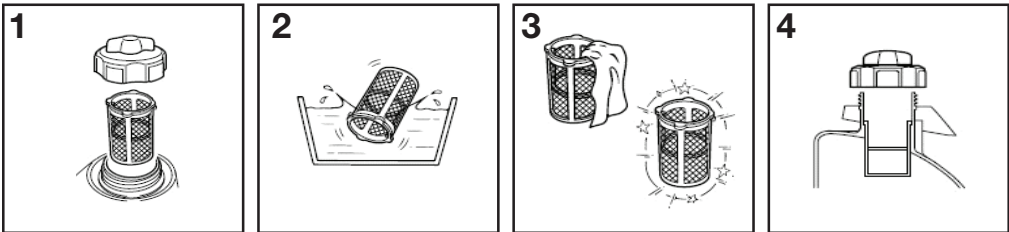

1. Remove the fuel cap and filter.
2. Clean the filter with solvent.
3. Wipe the filter.
4. Reinsert the filter.

8.8 EMISSION CONTROL SYSTEM

Emission Source

Exhaust gas contains carbon monoxide, nitrogen oxides (NOx) and hydrocarbons. It is very important to control the emissions of NOx and hydrocarbons as they are a major contributor to air pollution. Carbon monoxide is a poisonous gas. The emission of fuel vapors is a source of pollution as well. The lawn mower engine utilizes a precise air-fuel ratio and emission control system to reduce the emissions of carbon monoxide, NOx, hydrocarbons and evaporative fuel emissions.

Regulation

Your engine has been designed to meet current Environmental Protection Agency (EPA) clean air standards. The regulations dictate that the manufacturer provides operation and maintenance standards regarding the emission control systems. Tune up specifications are provided in the Specifications section and a description of the emission control system may be found in the appendix to this manual. Adherence to the following instruction will ensure your engine meets the emission control standards.

Modification

Modification of the emission control system may lead to increased emissions. Modification is defined as the following:

- Disassembling or modifying the function or parts of the intake, fuel or exhaust system.
- Modifying or destroying the speed governing function of the lawn mower.

Engine faults that may affect emission

Any of the following faults must be repaired immediately. Consult with your authorized service centre for diagnosis and repair:

- Hard starting or shut down after starting.
- Unstable idle speed.
- Shut down or backfire after applying an electrical load.
- Backfire or after fire.
- Black smoke and/or excessive fuel consumption.

Replacement parts and accessories

The parts making up the emission control system in your product's engine have

been specifically approved and certified by the regulatory agencies. You can trust that the replacement parts supplied by customer service have been manufactured to the same production standard as the original parts. The use of replacement parts or accessories which are not designed for your engine – may negatively affect the engine emission performance. Therefore only use replacements parts and accessories from a qualified service centre to guarantee that the replacement products will not adversely affect emission performance. Replacement parts other than those from an authorized service centre will void the warranty.

8.9 CARBURETOR MODIFICATION FOR HIGH ALTITUDE OPERATION (ABOVE 2,000 FEET)

NOTE

- This engine is equipped to run at altitudes below 2,000-ft.
- A high-altitude Main Jet is recommended when operated at 2,000 to 7,000-ft above sea level.
- At elevations above 7,000-ft the engine may experience decreased performance even with a high-altitude Main Jet.

At high altitudes the carburetor's air/fuel mixture becomes too rich, resulting in higher fuel consumption, lower performance, and carbon build-up on the spark plug. On the other hand, if the carburetor has been modified for high altitude operation and is operated below 2000-ft, the air/fuel mixture will then be too lean for low altitude use. Always use the correct Main Jet for your altitude.

The engine's carburetor, governor (if so equipped), and any other parts that control the air/fuel ratio will need to be adjusted by a qualified mechanic to allow efficient high-altitude use, and to prevent damage to the engine and any other devices used with this product. The fuel system on this engine may be influenced by operation at higher altitudes.

- Carburetor bowl may have gas in it which will leak upon removing the bolt.
- The mixing tube is held in place by the Main Jet and might fall out when it is removed. If it falls out, replace it in the same orientation before replacing the Main Jet.
- The Fuel Cup Seal and Bolt Seal may be damaged during removal and should be replaced with the new ones.

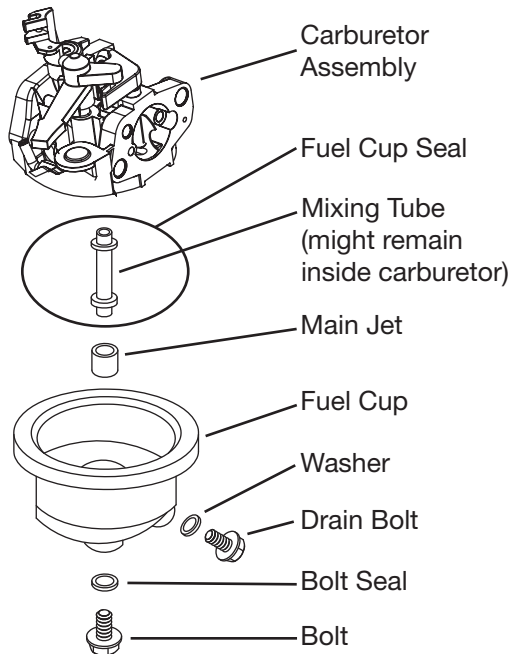

1. Turn off the engine.
2. Close the fuel valve.
3. Place a bowl under the fuel cup to catch any spilled fuel.
4. Unthread the bolt holding the fuel cup.
5. Remove the bolt, Bolt Seal, fuel cup, Fuel Cup Seal and Main Jet from the body of the carburetor assembly. A carburetor screwdriver (not included) is needed to remove and install the Main Jet.
6. Replace the Main Jet with the replacement Main Jet needed for your altitude range.
7. Replace the Fuel Cup Seal, fuel cup, Bolt Seal, and bolt. Tighten in place. DO NOT cross thread bolt when tightening. Finger tighten first and then use a wrench to make sure the bolt is properly threaded.
8. Wipe up any spilled fuel and allow excess to evaporate before starting engine. To prevent FIRE, DO NOT start the engine while the smell of fuel hangs in the air.

9. TRANSPORTATION & STORAGE

Transporting the Lawn Mower

- DO NOT use the lawn mower in the vehicle. The mower should ONLY be used while in a well ventilated area.
- Avoid exposing the lawn mower to prolonged direct sunlight while in an enclosed vehicle. The high temperature inside the vehicle could cause fuel to vaporize resulting in a possible explosion.
- Drain the lawn mower of fuel and oil before being transported on rough roads.
- Empty the gasoline tank
- Remove the spark plug cap from the spark plug.
- Clean the lawn mower from debris.
- Use the original packaging to ship whenever possible.

Draining the Fuel Tank

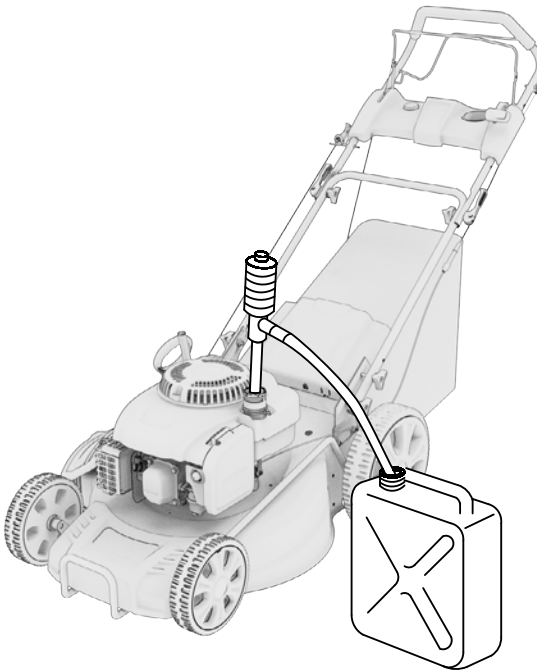

1. Turn OFF the engine. Remove the fuel cap.
2. Empty the fuel tank using a siphon and an approved gasoline container.
3. Loosen the carburetor drain bolt to discharge all gasoline from inside of the carburetor.

Storage

Gasoline can oxidize in as little as 30 days, causing gum and varnish to build up in fuel system components.

NOTE

- Ensure that the storage area is free of excess humidity and dust.
- Drain the fuel tank and the carburetor.
- Clean the lawn mower from debris.

Storage Duration	Preparation Required
Less than 1 Month	<ul style="list-style-type: none">■ No storage preparation required, simply store as is.
1 Month to 1 Year	<ul style="list-style-type: none">■ Drain the old gas and completely fill the tank with fresh gas before storage. Add fuel stabilizer according to the manufacturer's directions. Adding a quality fuel stabilizer can keep gas fresh for up to a year.■ Remove the battery and charge it every 3 months.
1 Year or More	<ul style="list-style-type: none">■ Drain off the gasoline from the fuel tank, and store in a suitable container. This will help prevent deposits from forming in the fuel system.■ Turn the fuel switch to OPEN and loosen the carburetor drain bolt. Take off the spark plug cap and revolve the engine 3 or 4 times, by pulling the recoil handle, to fully discharge the gasoline from the fuel lines.■ Change oil while engine is still warm from operation.■ Remove the spark plug, and pour a tablespoon of clean engine oil (10~20ml) into the cylinder. Revolve the engine several times by pulling on the recoil start to distribute the oil. Reinstall the spark plug. Pull the starter grip slowly until you feel resistance. At this point, the piston is coming up on its compression stroke and both the intake and exhaust valves are closed. This position helps to protect the engine from internal corrosion.

10. TROUBLESHOOTING

Problem	Look for	Solution
Loud while running, machine vibrates heavily.	Screws are loose	Check screws.
	Blade fasteners are loose.	Check blade fasteners.
	Blade is unbalanced.	Replace blade.
	Poor connection of battery circuit.	Check and clean the wiring connection.
Engine does not start.	Start/stop lever not pressed.	Press start/stop lever.
	Spark plug is defective.	Replace spark plug.
	Is the cutting blade worn or damaged?	Contact an authorized dealer to replace it.
	Fuel tank is empty.	Refill with fuel.
	Engine may be flooded.	Remove plug and dry.
Engine runs unsteadily.	Air filter is soiled.	Clean the air filter.
	Spark plug is soiled.	Clean the spark plug.
Uneven mowing results.	Blade is blunt.	Sharpen the blade.
	Cutting height is too low.	Set correct height.
Grass bag is not filled sufficiently.	Blade is worn.	Replace the blade.
	Grass bag is clogged.	Empty the grass bag.
	Is the cutting height right?	Correct the cutting height.
	Is the lawn/grass wet?	Allow the lawn to dry.
	Is the discharge channel/housing blocked?	Clean the discharge channel/housing.
	Is the underside of the mower deck clogged?	Clean the underside of the mower deck.

11. TECHNICAL SPECIFICATIONS

	SPECIFICATIONS	HH0403	BM1740	BLM2050E
LAWN MOWER	HH Number	5124-044	5124-042	5124-041
	Functions	Bag/Mulch/Side	Bag/Mulch/Side	Bag/Mulch/Side
	Deck Width	22 in	22 in	22 in
	Cutting Width	21 in	21 in	21 in
	Min.Cutting Height	1 in (25 mm)	1 in (25 mm)	1 in (25 mm)
	Max.Cutting Height	3 in (75 mm)	3 in (75 mm)	3 in (75 mm)
	Handle Height Adjust	3-position	3-position	3-position
	Deck Height Adjust	Single-lever, 8-position	Single-lever, 8-position	Single-lever, 8-position
	Blade	Straight	Straight	Straight
	Number of Blades	1	1	1
	Grass catcher	Fabric Bag	Fabric Bag	Fabric Bag
	Front / Rear wheel	8/12 in	8/12 in	8/12 in
ENGINE	Type	3.8 HP, Single Cylinder, forced air cooling, 4-stroke, OHV	3.8 HP, Single Cylinder, forced air cooling, 4-stroke, OHV	5.2 HP, Single Cylinder, forced air cooling, 4-stroke, OHV
	Displacement (cm ³)	173cc	173cc	200cc
	RPM	2800	2800	2800
	Oil capacity	400 mL / 14 oz. (10W30)	400 mL / 14 oz. (10W30)	400 mL / 14 oz. (10W30)
	Fuel tank capacity	1 L / 0.3 Gal	1 L / 0.3 Gal	1.2 L / 0.3 Gal
	Fuel Type	Unleaded gasoline 87+ Octane	Unleaded gasoline 87+ Octane	Unleaded gasoline 87+ Octane
UNIT	L x W x H	62 x 28 x 42.5 in	62 x 28 x 42.5 in	62 x 28 x 42.5 in
	Gross Weight	70.4 lbs / 32 kg	72.6 lbs / 33 kg	81.4 lbs / 37 kg

12. LIMITED WARRANTY

This product is distributed by:

Midland Power Inc.

376 Magnetic Drive, Toronto, ON M3J 2C4, Canada

Warranty

Beginning at the time of retail purchase and for the duration of the warranty period Midland Power Inc. (Midland) warrants that Equipment manufactured by it is warranted to be free from defects in material and workmanship. Midland will, at its sole discretion, replace or repair any part(s) which, upon evaluation and testing by Midland or an authorized service center, show a defect in workmanship or material. Valid proof of purchase must be submitted online for registration with Midland, or presented to Midland at time of claim, for warranty to be valid. This warranty is not transferable from the original owner.

Limited Warranty Period:

Non-commercial use:

- Year 1, 2 and 3 - Parts and Labour
- Year 4 and 5 - Parts

Commercial use:

- First 6 Months - Parts and Labour

Replacement parts sold to a consumer or installed by an authorized service center are warranted for a period of 90 days from date of purchase. Labour must be performed by an authorized service center unless given Midland's prior written approval. Midland will not bear any transportation or shipping fees to or from an authorized service center. Service calls, travel charges, overtime, or weekend rates, are not covered.

This warranty does NOT cover:

- a. Any repairs required as a result of any parts not supplied by Midland, and this part is responsible for the failure or malfunction;
- b. Any Equipment modified, altered, disassembled or remodelled;
- c. Any repairs required as a result of a failure to install, maintain, store, transport, or operate the Equipment in accordance with standard practices set out in the user guide;
- d. Damage that occurred after receipt of equipment, not caused by defects in workmanship or material;
- e. Normal maintenance services, as outlined in the user guide and intended for a consumer to perform;

- f. Replacement of parts made in connection with normal maintenance services including oils, adhesives, additives, fuel, filters, brushes, belts, lubricants, spark plugs, gaskets, seals, fasteners, wires, tubes, pipes, fittings, wheels, batteries, and other expendables susceptible to natural wear;
- g. Any accessory or attachment.

Any battery supplied with this Equipment is considered a consumable item and is excluded from this warranty. Batteries can be damaged by shock, shorting terminals, heat, acid spillage, neglect, and other factors. It is the customer's responsibility to take great care when handling a battery so no spillage of acid occurs which may cause corrosion.

Midland disclaims any responsibility for loss of time or use of the product, transportation, or towing costs or any other indirect, incidental, or consequential damage, inconvenience or commercial loss.

This warranty is the entire and only warranty given by Midland for Midland products or equipment. No agent or employee is authorized to extend or enlarge this warranty on behalf of Midland by any written or verbal statement or advertisement.

California

The California Air Resources Board and Midland Power Inc. are pleased to explain the emission control system warranty on your Midland Power Inc. engine. In California, new spark-ignited small off-road equipment engines must be designed, built, and equipped to meet the State's stringent anti-smog standards.

Other States, U.S. territories, and Canada

In other areas of the United States and in Canada, your engine must be designed, built, and equipped to meet the U.S. EPA and Environment Canada emission standards for spark-ignited engines at or below 19 kilowatts.

All of the United States and Canada

Midland Power Inc. must warrant the emission control system on your power equipment engine for the period of time listed below, provided there has been no abuse, neglect, or improper maintenance of your power equipment engine. Where a warrantable condition exists, Midland Power Inc. will repair your power equipment engine at no cost to you including diagnosis, parts, and labor.

Your emission control system may include such parts as the carburetor or fuel injection system, the ignition system, and catalytic converter. Also included may be hoses, connectors, and other emission-related assemblies.

Emission Control System Warranty Parts:

This list applies to parts supplied by Midland Power Inc. and does not cover parts supplied by the equipment manufacturer. Please see the original equipment manufacturer's emissions warranty for non-Midland Power Inc. parts.

Consumable parts are covered up to a maximum of 30 days.

SYSTEMS COVERED IN WARRANTY	PARTS DESCRIPTION
Fuel Metering	Carburetor assembly (includes starting enrichment system), Engine temperature sensor, Engine control module, Fuel regulator, Intake manifold
Evaporative	Fuel Tank, Fuel Cap, Fuel Hoses, Vapor Hoses, Carbon Canister, Canister Mounting Brackets, Fuel Strainer, Fuel cock, Fuel Pump, Fuel Hose Joint, Canister Purge Hose Joint
Exhaust	Catalyst, Exhaust Manifold
Air Induction	Air filter housing, Air filter element
Ignition	Flywheel magneto, Ignition pulse generator, Crankshaft position sensor, Power coil, Ignition coil assembly, Ignition control module, Spark plug cap, Spark plug
Crankcase Emission Control	Crankcase breather tube, Oil filler cap
Miscellaneous Parts	Tubing, fittings, seals, gaskets, and clamps associated with these listed systems

BENCHMARK[™]

**MIDLAND
POWER** 

Customer Service

Online: www.benchmark.midlandpowerinc.com

E-mail: support@midlandpowerinc.com

Toll Free: 1-877-528-3772

Enjoy!

Be sure to check www.benchmark.midlandpowerinc.com for updates regarding your product.

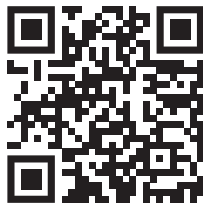



BENCHMARKTM_{MC}

HH0403, BM1740, BLM2050E