

BENCHMARK™

BW SERIES



MANUAL



This product is supported by **Midland Power**. Contact us directly for assistance and warranty help. Do not return this product to store.

You must register online for your warranty to be valid. It only takes a minute, do it now while you still have your purchase receipt.

Register Your Product Online

[www.benchmark.midlandpowerinc.com/
register-warranty](http://www.benchmark.midlandpowerinc.com/register-warranty)



Support for your product is available online, including parts, service center locations, and live expert advice.

Visit us online at

www.benchmark.midlandpowerinc.com



Or call us anytime at **1-877-528-3772**.

Thanks for choosing the BW Series!

You're excited to get started, we'll keep this brief.

READ THIS ENTIRE GUIDE BEFORE USING THIS PRODUCT AND SAVE FOR LATER USE.

This user guide contains important instructions including safety, setup, operation, and maintenance that must be followed. All information in this guide is based on information available at the time of print. This guide or revised editions can be found on our website for download. No part of this publication may be reproduced without written permission.

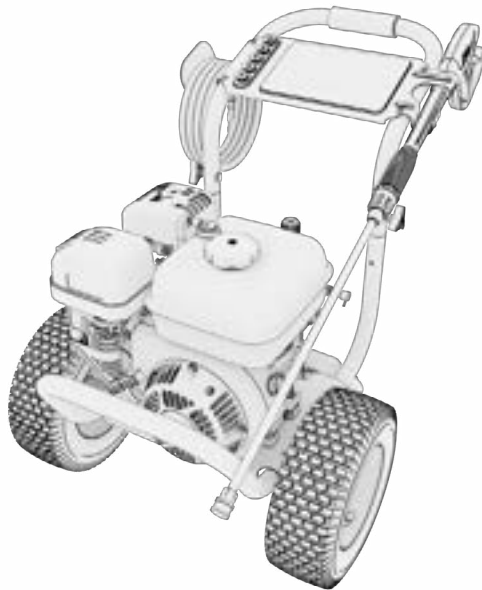

THIS PRODUCT MEETS ALL CERTIFICATION REQUIREMENTS FROM:



The engine exhaust from this product contains chemicals known to cause cancer, birth defects or other reproductive harm.



©2023 Benchmark. All Rights Reserved.

BW_Manual_EN_2023-04-13

TABLE OF CONTENTS

1. Safety	1
2. Learn About Your Pressure washer	5
3. Getting Started	7
3.1 Assembling the Handle	7
3.2 Prepare the Air Filter	8
3.3 Replace the Temporary Pump Oil Dipstick	9
3.4 Add Engine Oil	10
4. Pre-Operation Check	12
4.1 Check Pump Oil Level	12
4.2 Check the Fuel Level	13
4.3 Check the Cold Water Supply	14
4.4 Assemble the Spray Gun and Hoses	14
5. Using your Pressure washer	18
5.1 Starting Your Pressure Washer	19
5.2 Stopping the Engine	21
6. Using Your Pressure washer	22
6.1. Using the Spray Wand	22
6.2. Using Spray Nozzles	23
6.3 Working with Detergents	25
6.4 Pressure Regulator	27
6.5 Carburetor Modification for High Altitude Operation	28
7. Maintenance	30
7.1 Maintenance Schedule	31
7.2 Changing the Engine Oil	32
7.3 Changing the Pump Oil	34
7.4 Cleaning the Air-Filter	35
7.5 Nozzle Cleaning	36
7.6 Cleaning Water Inlet Filter	36
7.7 Spark Plug Service	36
7.8 Spark Arrester Maintenance	37
7.9 Fuel Filter Maintenance	37
7.10 Emission Control System	38
8. Transportation & Storage	40
9. Troubleshooting	43
10. Technical Specifications	45
11. Limited Warranty	46

1. SAFETY

⚠ DANGER	
<p>Using an engine indoors CAN KILL YOU IN MINUTES. Engine exhaust contains carbon monoxide. This is a poison you cannot see or smell.</p>	
	
<p>NEVER use inside a home or garage, EVEN IF doors and windows are open.</p>	<p>Only use OUTSIDE and far away from windows, doors, and vents.</p>
<p>Avoid other engine hazards. READ MANUAL BEFORE USE.</p>	

⚠ DANGER! ⚠

Using a gas powered pressure washer indoors can kill you in minutes.

The engine exhaust from this product contains chemicals known to cause cancer, birth defects or other reproductive harm.

1.1 OPERATOR SAFETY

⚠ WARNING!

- Always perform an oil, fuel and air filter check before starting the engine.
- Properly clean and maintain the equipment.
- Operate the pressure washer according to instructions for safe and dependable service.
- Before operating the pressure washer, read the user guide carefully. Otherwise, it may result in personal injuries or equipment damage.
- Never run the pressure washer in an enclosed area to avoid harm from exhaust emissions of a poisonous carbon monoxide gas.
- Be careful not to touch the exhaust system during operation due to risk of burns.
- Pay attention to the warning labels. The engine exhaust system will become heated during operation and remain hot immediately after the engine is stopped.
- Gasoline is a highly flammable and explosive liquid. Refuel in a well ventilated area with the engine stopped.
- Use of gasoline with an ethanol content greater than 10% can damage the engine and fuel system and will void the manufacturer's warranty.
- When refueling the pressure washer, keep it away from cigarettes, open

flames, smoke and/or sparks.

- Place the pressure washer at least 3 feet away from buildings or other equipment during operation.
- Run the pressure washer on a level surface. Tilting the pressure washer may result in fuel spills.
- Know how to stop the pressure washer quickly and understand operation of all the controls. Never permit anyone to operate the pressure washer without proper instructions.
- Keep children, pets and machinery with rotating parts away during operation.
- Do not operate the pressure washer in rain or snow.
- Do not touch the spark plug while the engine is operating or shortly after the engine has been shut down.
- Wear ear and eye protection while operating this unit.

1.2 USE SAFETY

⚠ WARNING!

- NEVER direct the water spray towards electrical wiring, devices, or directly at the pressure washer itself. Fatal electric shock may occur.
- NEVER direct the water flow at people. The high pressure jet can be dangerous if misused and must not be directed at people, animals, electrical devices or the unit itself. **DO NOT TREAT FLUID INJECTION AS A SIMPLE CUT!** Seek medical help immediately.
- NEVER spray flammable liquids, risk of explosion. Operate only where open flame or torch is permitted.
- Always operate on dry, solid level ground.
- DO NOT expose this product to excessive moisture, dust, or dirt.
- DO NOT use in areas where fumes from paint solvents or flammable liquids pose a potential hazard.
- Inspect before each use, ensure all nuts, bolts, screws, hydraulic fittings, hose clamps, wheels. etc. are securely tightened. Always check the oil level before operating. Never operate when the product is in poor mechanical condition.
- Never move this product while spraying.
- DO NOT run the engine at high speed when you are not using the product.
- DO NOT use acids, solvents, alkaline, or flammable substances in this product. They may cause injuries to the operator and will permanently

damage the machine.

- Only use detergents that are designed to be specifically used with a pressure washer. The use of other cleaning detergents may void the warranty.
- The spray gun will kick, hold with both hands.
- Never run the unit dry, always be sure the water supply is turned on fully before operating the unit.
- Know how to stop the product and bleed pressure quickly. Be thoroughly familiar with the controls.
- DO NOT operate the pressure washer without the water turned on.
- DO NOT overreach or stand on unstable surface. Keep good footing and balance at all times.
- Wear proper eye and ear protection while operating.

1.3 MAINTENANCE SAFETY

⚠ WARNING!

- Turn off the engine before performing any maintenance. Failure to do so can cause severe personal injury or death.
- Before performing maintenance depressurize the unit by turning off the water supply and squeezing the trigger of the spray wand until water stops flowing.
- Use rubber gloves when coming into contact with engine oil.
- After any maintenance is performed, wash immediately using soap and clean water, repeated exposure to lubricant may cause skin irritation.
- Do not clean the filter element with flammable liquids like gasoline, an explosion may occur.
- Allow the pressure washer set to cool down before performing any maintenance.
- Do not spray the pressure washer itself.
- Always stop the pressure washer set before removing the oil filler cap.
- Only qualified maintenance personnel with knowledge of fuels and machinery hazards should perform maintenance procedures.
- Do not let water in the pump freeze. See the storage section for further details on how to store properly during the winter.
- See 'Maintenance Schedule' for the recommended maintenance schedule.

1.4 OTHER SAFETY TIPS

⚠ WARNING ⚠
AVERTISSEMENT

 **TOXIC FUMES HAZARD.** Running engines give off carbon monoxide, an odourless poisonous gas that can cause nausea, fainting, or death. Do not start engine indoors or in an enclosed area, even if the windows and doors are open.

DANGER TOXIQUE. Faire fonctionner un moteur dégage de l'oxyde de carbone, un gaz inodore toxique qui peut provoquer la nausée, évanouissement ou la mort. Ne démarrer pas le moteur à l'intérieur ou dans une espace clos, meme si les fenêtres et les portes sont ouvertes.

⚠ WARNING!

- Running engines give off carbon monoxide, an odourless poisonous gas that can cause nausea, fainting, or death. Do not start engine indoors or in an enclosed area even if the windows and doors are open.
- If you start to feel sick, dizzy, or weak after the pressure washer has been running, move to fresh air **RIGHT AWAY**. See a doctor. You could have carbon monoxide poisoning.
- Pressure washers vibrate in normal use. During and after the use of the pressure washer, inspect the pressure washer as well as hoses connected to it for damage resulting from vibration. Have damaged items repaired or replaced as necessary. Do not use hoses that show signs of damage such as broken or cracked insulation or damaged connectors.

2. LEARN ABOUT YOUR PRESSURE WASHER

This section will show you how to identify key parts of your pressure washer. Going over the terminology below will make sure we're on the same page.

2.1 COMPONENT IDENTIFICATION

BW3500 and BW3800

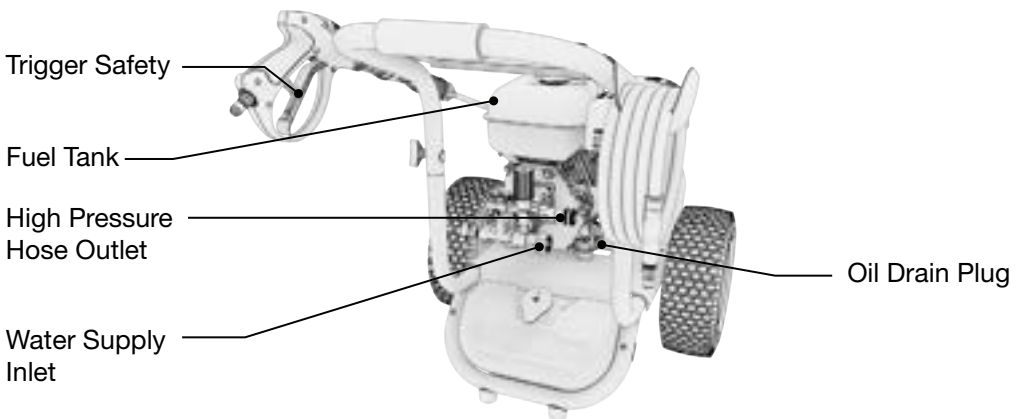
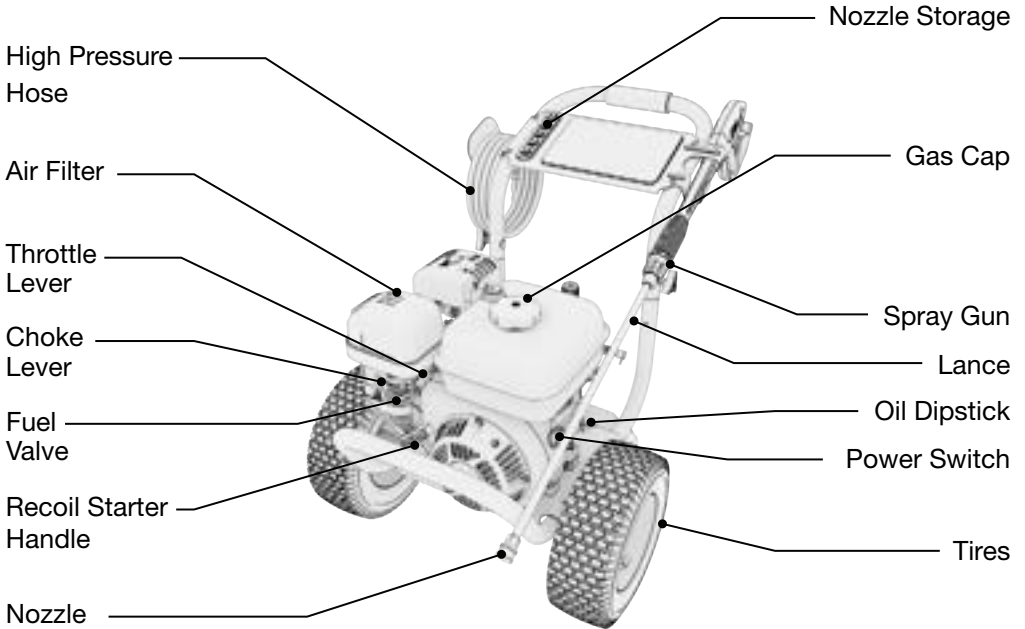

BW4400

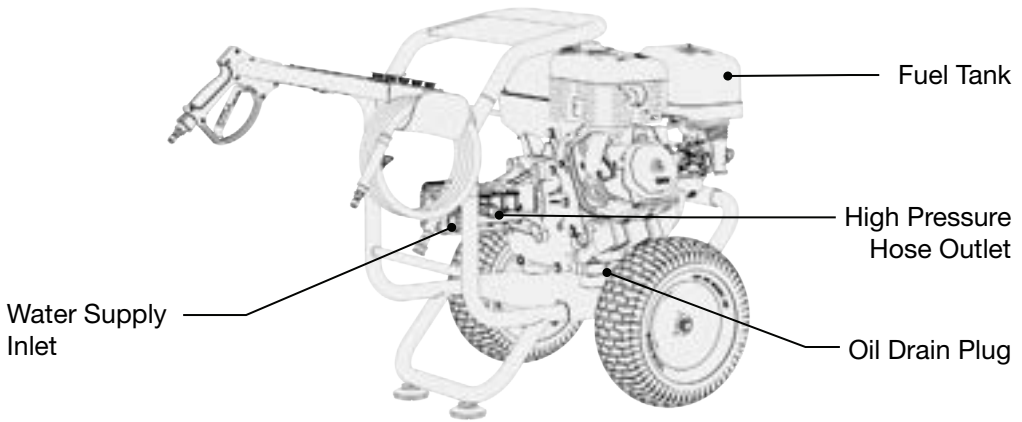
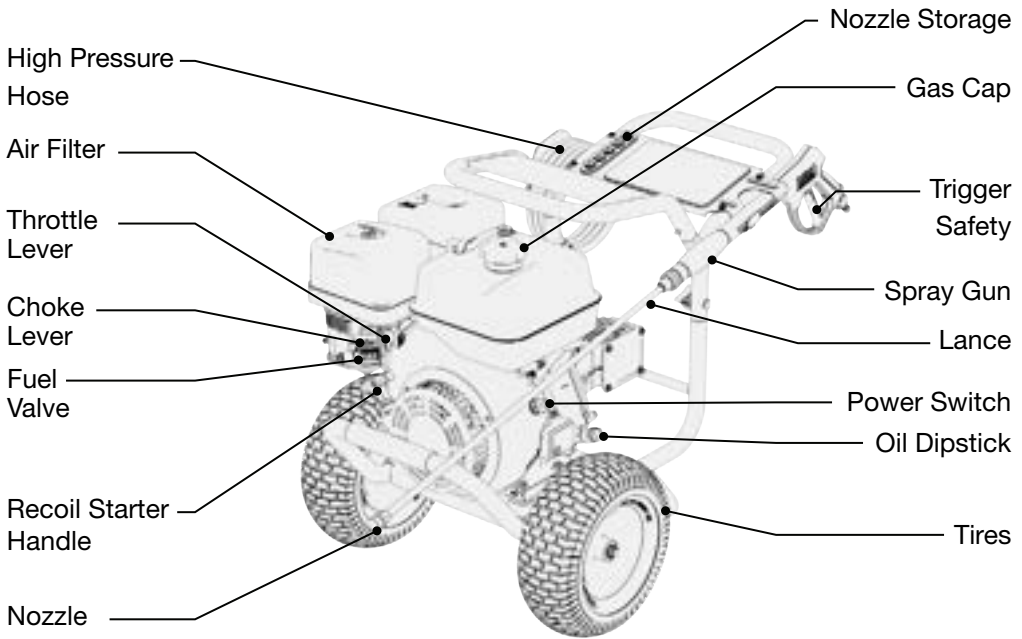

3. GETTING STARTED

Setup of your pressure washer is designed to get you up and running as quickly as possible. Cut the four corners of the carton from top to bottom instead of attempting to lift it out of the box.

3.1 ASSEMBLING THE HANDLE

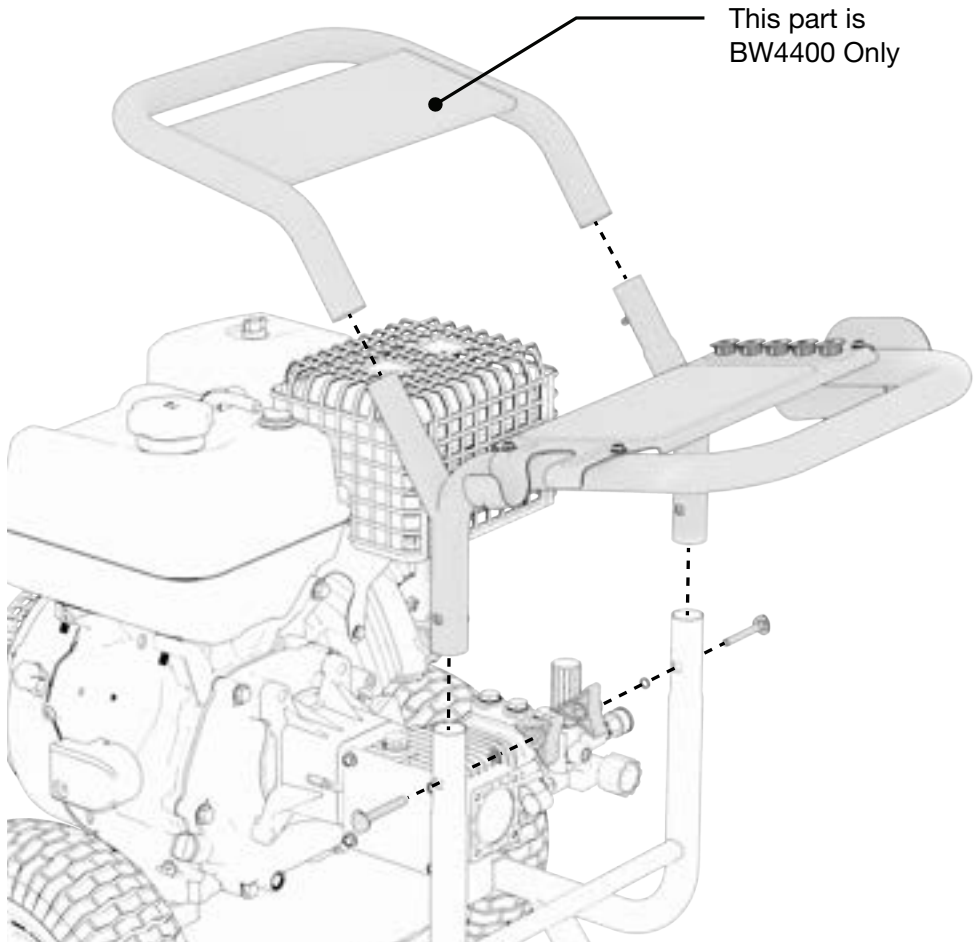

1. Slide the main handle onto the frame.
2. Pass the saddle bolts through the hole from the outside.
3. Tighten the knobs to secure it in place.
4. If equipped with an upper handle (BW4400 only), slide the upper handle onto the main handle. Press in the spring pins until the upper handle slides down all the way and snaps in place.

3.2 PREPARE THE AIR FILTER

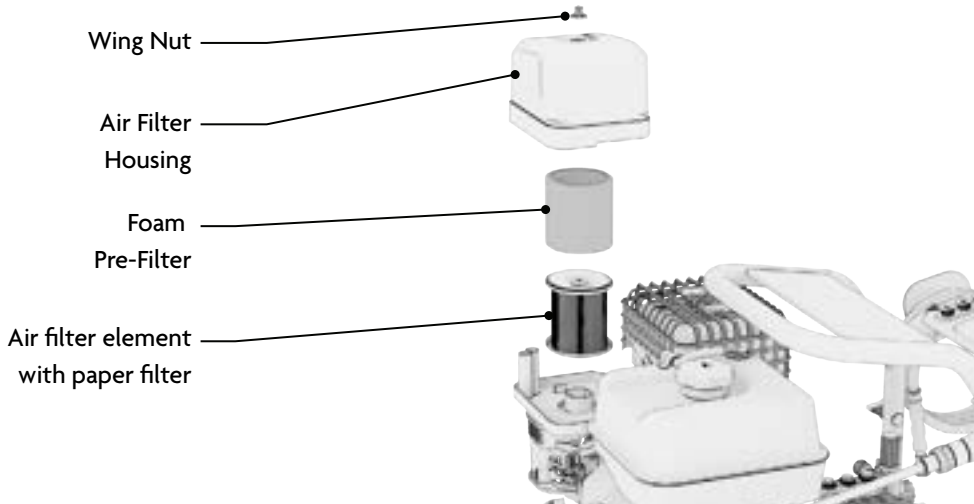

Prepare the air filter before your first use. Check the maintenance schedule for a complete cleaning guide.

1. Loosen top nut and remove the air filter cover. Remove the air filter element.
2. Separate the *foam* pre-filter from the air filter element.
3. Inspect the *paper* filter inside the air filter element, shake filter or blow with air to remove any dust and debris. Replace either filter if damaged.
4. Clean the *foam* pre-filter with soap and water or solvent and let dry completely.
5. Wearing gloves, add new engine oil to the *foam* pre-filter. Work oil into *foam* filter until saturated.
6. Squeeze and repeatedly use a towel to pat out excess oil. The result should be a very lightly oiled pre-filter, if excess oil remains in the *foam* filter it can seep through to the *paper* filter and damage it.
7. Add *foam* pre-filter back to air filter element and reinstall onto engine.

NOTE

- Running the engine without the air filter will quickly degrade the engine
- Always inspect air filter before using the pressure washer. Check and clean the air filter according to the maintenance schedule.

3.3 REPLACE THE TEMPORARY PUMP OIL DIPSTICK

BW3800 and BW4400 Only

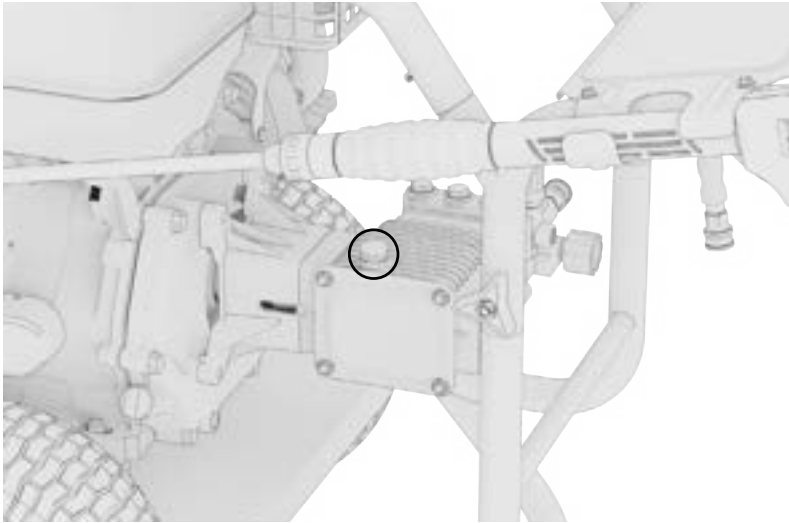

Your pressure washer ships with a red non-vented oil fill plug. Before starting the pump replace the red non-vented dipstick with the included vented oil fill plug.

3.4 ADD ENGINE OIL

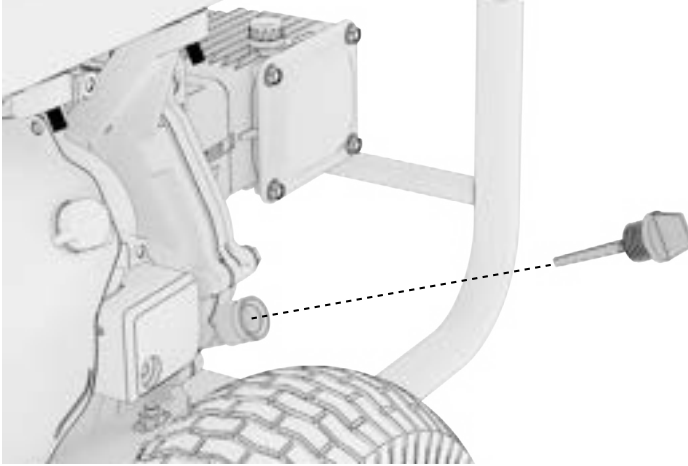

1. Ensure the pressure washer is on a level surface.
2. Unscrew one of the two oil dipsticks and clean the dipstick.
3. Check the oil level by reinserting the oil dipstick *without* screwing it back in. Remove the dipstick and examine the oil level. If the level is at or below the minimum oil level marked on the dipstick, refill to the maximum oil level mark.
4. Reinsert the dipstick and tighten securely.

NOTE

- Oil max. capacity:
 - BW3500: 600 mL
 - BW3800: 700 mL
 - BW4400: 1.1 L
- Do not tilt the pressure washer when adding engine oil. This could result in overfilling and damage to the engine.
- Using non-detergent or 2-stroke oil could shorten the engine's working life.
- Use high quality engine oil with strong detergents.
- Handle and store the engine oil with care, avoid getting dirt or dust into the engine oil.
- Do not mix different engine oils.
- Before the engine oil falls below the safety margin, the low oil alert system will automatically shut off the engine. The low oil light will turn on.
- To avoid the inconvenience of unexpected engine shutoff, check the engine oil level as often as possible.
- Use 4-stroke engine oil, certified to meet or exceed API standard SG, SF, SAE ratings

Effective Viscosity Range of Engine Oils

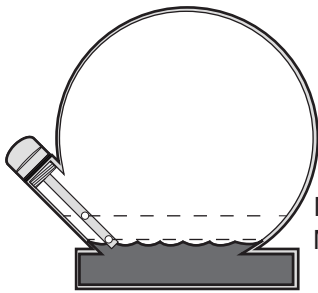
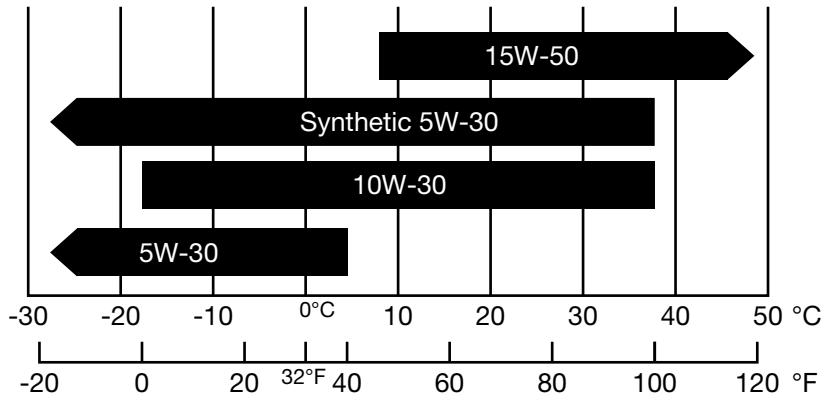

Maximum Oil Level
Minimum Oil Level

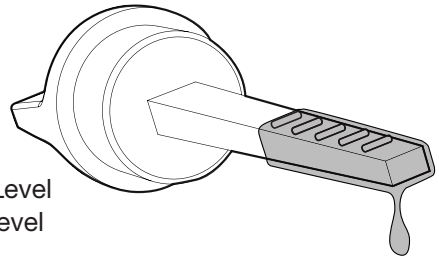

4. PRE-OPERATION CHECK

These quick checks should be done each time the pressure washer is started to ensure you get the most out of your pressure washer.

Set the pressure washer on a level surface and the power switch to OFF.

⚠ WARNING!

Exhaust gas contains poisonous carbon monoxide. Never run the pressure washer in an enclosed area. Be sure to provide adequate ventilation. Operate the pressure washer on a level surface. If the pressure washer is tilted, fuel spillage may result. Keep away from rotating parts while the pressure washer is running. The pressure washer is air-cooled and may be damaged if ventilation is inadequate.

4.1 CHECK PUMP OIL LEVEL

1. Ensure the pressure washer is on a level surface.
2. Unscrew one of the two oil dipsticks and clean the dipstick.
3. Check the oil level by reinserting the oil dipstick *without* screwing it back in. Remove the dipstick and examine the oil level. If the level is at or below the minimum oil level marked on the dipstick, refill to the maximum oil level mark.
4. Reinsert the dipstick and tighten securely.

4.2 CHECK THE FUEL LEVEL

⚠ WARNING!

Gasoline is highly flammable and explosive under certain conditions. Refuel in a well-ventilated area with the engine stopped. Do not smoke or allow open flames or sparks in the area where the pressure washer is being refueled or where gasoline is stored. Do not overfill the tank. Be careful not to spill fuel when refueling. Wipe up any spilled gasoline and let the area dry before starting the engine.

Gasoline substitutes such as gasohol are not recommended. They may be harmful to the fuel system components.

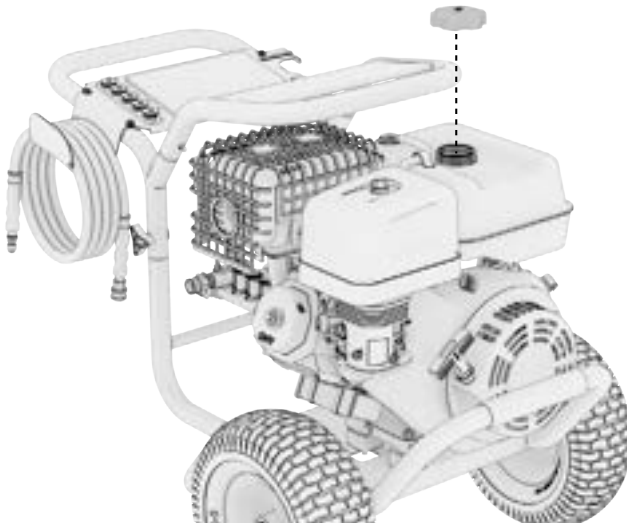

1. Check the fuel level by removing the fuel tank cap to visually check the level.
2. Add fuel until the level reaches 1.5" below the top of the neck. Tighten the fuel cap securely after refilling.

NOTE

- Only use unleaded gasoline (Pump Octane 87 or higher).
- Never use stale or contaminated gasoline, or an oil/gasoline mixture.
- Avoid getting dirt or water into the fuel tank.
- Do not use a mixture of gasoline containing methanol. This will cause serious damage to the engine.
- Use of gasoline with an ethanol content greater than 10% can damage the engine and fuel system and will void the manufacturer's warranty.

4.3 CHECK THE COLD WATER SUPPLY

- Check local regulations of your municipal water company to check if a backflow prevention device is required when hooking up to drinking water. This ensures no feedback of chemicals will return to the water supply. Use a water filter to avoid potential damage from dirt in the water supply.
- Garden hose must be at least 3/4" diameter.
- Flow rate of water supply must not fall below 8.0GPM. You can ensure this by making sure your garden hose can fill a 5 gallon pail in 38 seconds or less.
- The water supply temperature must not exceed 40°C/104°F
- Never use the pressure washer to draw in water contaminated with solvents eg. paint thinners, gasoline, oil etc.
- Always prevent debris from being drawn into the unit by using a clean water source and additional water filter.
- DO NOT operate pressure washer without the water turned on.

4.4 ASSEMBLE THE SPRAY GUN AND HOSES

⚠ DANGER! ⚠

NEVER direct the water flow at people. The high pressure jet can be dangerous if misused and must not be directed at people, animals, electrical devices or the unit itself. DO NOT TREAT FLUID INJECTION AS A SIMPLE CUT! Seek medical help immediately.



1. Rotate the coupler on the trigger handle assembly clockwise to tighten the spray wand. Tighten by hand.



2. Attach the spray gun to the high pressure hose by pulling back on the collar of the female hose fitting and inserting the male spray gun end into it. Tug on the connection to ensure the connection is secured.

Install the Detergent Siphon Hose

BW3500

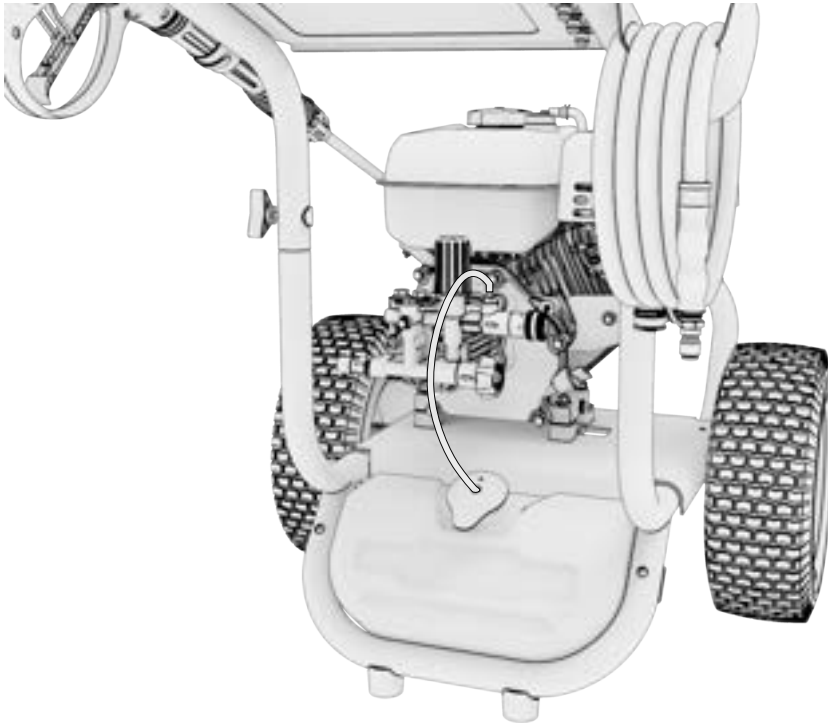

BW3800

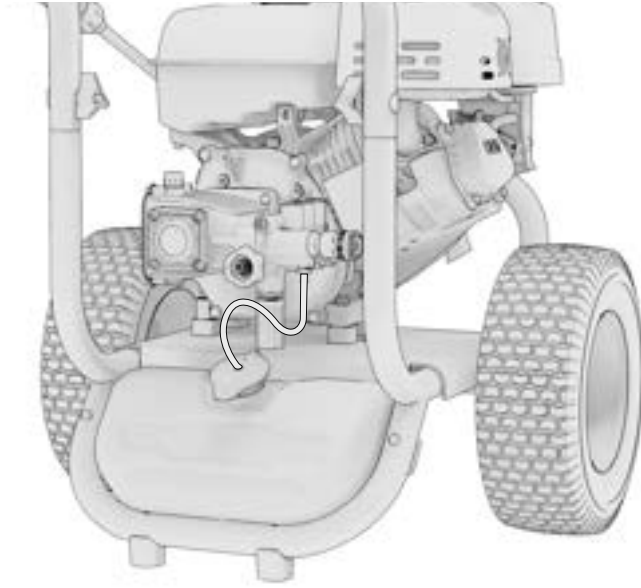

BW4400

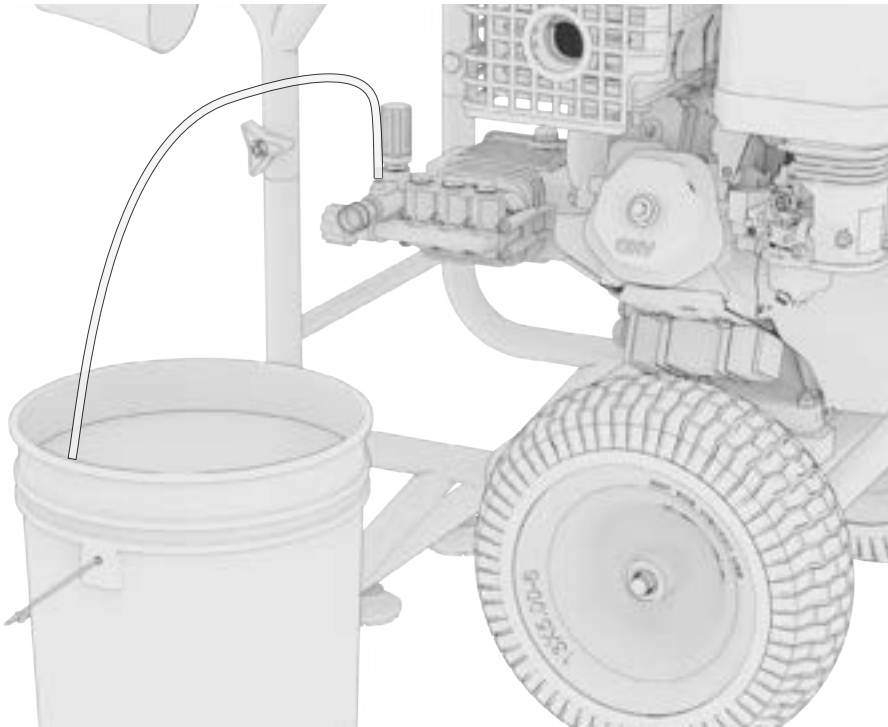

1. Attach one end of the detergent siphon hose to the barb fitting near the high pressure hose connection of the pump.
2. Place the other end of the siphon hose with filter into the built-in detergent

tank (BW3500 and BW3800) or into the container (BW4400) with the detergent solution.

NOTE

- The soap nozzle will draw detergent at a ratio of 1:25.

Hook Up the High Pressure Hose

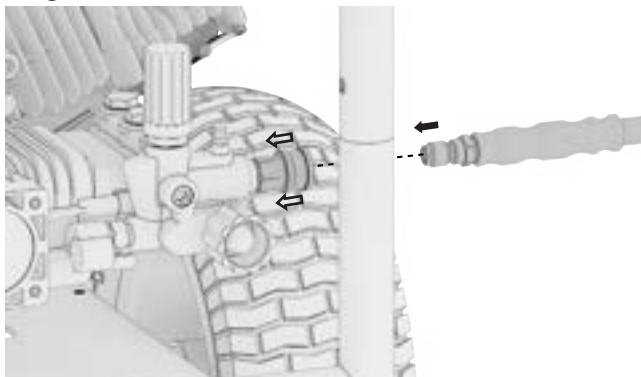

1. Attach the end of the high pressure hose to the high pressure outlet on the pump by pulling back on the collar of the female pump fitting and inserting the male hose end into it.
2. Attach the other end of the high pressure hose to the spray wand.

Hook Up the Water Supply Hose

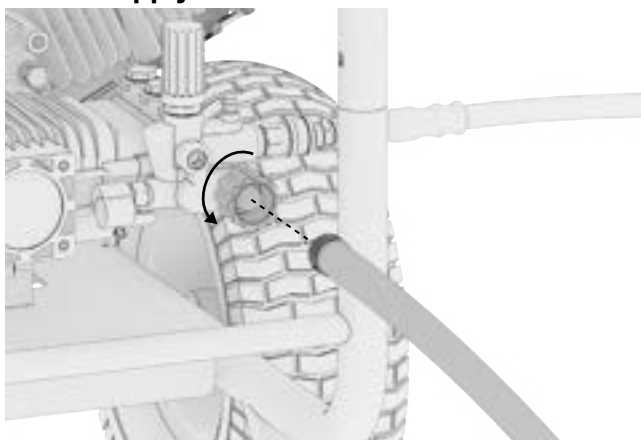



1. Connect the garden hose by threading it onto the pump.

NOTE

- Do not start the engine without the water supply connected and turned on. Water supply must deliver at least 8.0GPM. Do not draw from standing water supply. Water temperature must not exceed 100°F (37.7°C).

5. USING YOUR PRESSURE WASHER

⚠ DANGER! ⚠

⚠ DANGER	
Using an engine indoors CAN KILL YOU IN MINUTES . Engine exhaust contains carbon monoxide. This is a poison you cannot see or smell.	
 NEVER use inside a home or garage, EVEN IF doors and windows are open.	 Only use OUTSIDE and far away from windows, doors, and vents.
Avoid other engine hazards. READ MANUAL BEFORE USE.	

Using a pressure washer indoors WILL KILL YOU IN MINUTES.

Pressure washer exhaust contains high levels of carbon monoxide (CO), a poisonous gas you cannot see or smell. If you can smell the pressure washer exhaust you are breathing CO. Even if you cannot smell the exhaust, you could be breathing CO.

NEVER use a pressure washer inside a home, garage, crawlspace, or other partly enclosed area, deadly levels of carbon monoxide can build up in these areas. Using a fan or opening windows and doors will **NOT** supply enough fresh air.

ONLY use a pressure washer outdoors and far away from open windows, doors, and vents. These openings can pull in pressure washer exhaust. Even when you use a pressure washer correctly, CO may leak into the home. **ALWAYS** use a CO alarm in your home.

If you start to feel sick, dizzy, or weak after the pressure washer has been running, move to fresh air **RIGHT AWAY** and seek medical attention. You could have carbon monoxide poisoning. Never run the pressure washer in an enclosed or even partially enclosed area where people may be present.

⚠ DANGER! ⚠

NEVER direct the water flow at people. The high pressure jet can be dangerous if misused and must not be directed at people, animals, electrical devices or the unit itself. **DO NOT TREAT FLUID INJECTION AS A SIMPLE CUT!** Seek medical help immediately.

⚠ WARNING!

Do not run the pump without connecting to the water supply and turning the water on. Failure to do so could damage the pressure washer. Failure to follow these instructions will void product warranty.

Water that passes through this unit is not safe to drink.

5.1 STARTING YOUR PRESSURE WASHER

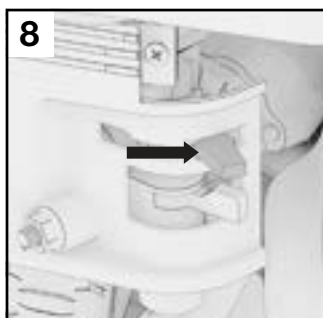
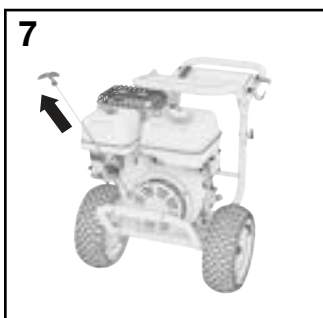
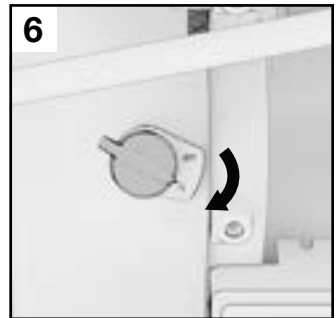
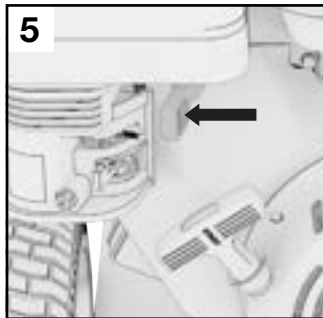
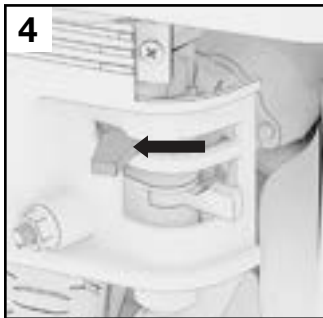
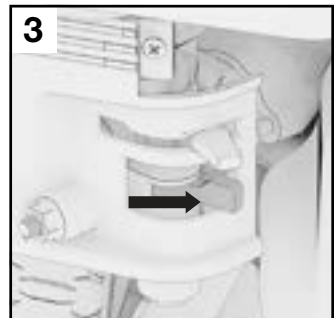
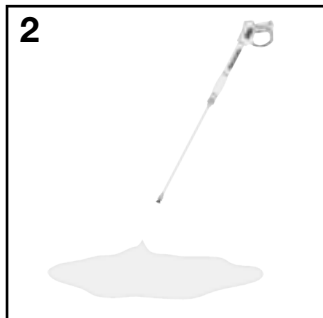
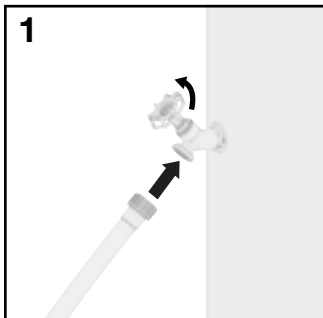

1. Turn on water supply to full.
2. Purge the air from the pump by releasing the safety and squeezing the trigger of the spray gun until a steady stream flows out.
3. Turn the fuel valve to OPEN position.
4. Turn the choke lever to START position.
5. Turn the throttle lever to full throttle (Rabbit).
6. Turn the engine power switch to the ON position.
7. Pull the recoil starter slowly until resistance is felt, then pull rapidly. Squeeze the gun trigger and release the water pressure after every failed attempt to start the pressure washer.
8. Let engine run for several seconds and then slowly turn the choke lever towards RUN as the engine warms up until the choke is fully in RUN position.

NOTE

- DO NOT allow the unit to run for more than 2 minutes without pulling the trigger to release water pressure. This could cause overheating and damage to the pump. When the temperature inside the pump gets too high the thermal relief valve will temporarily open and release a spray of water from the pump to lower the internal temperature.

5.2 STOPPING THE ENGINE

Normal Operation

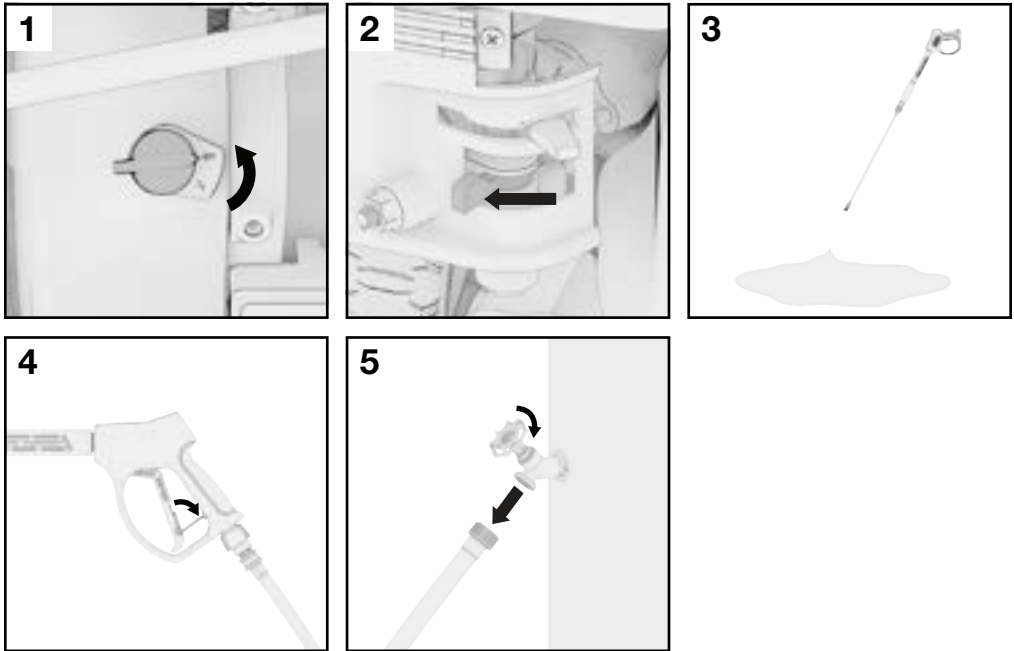

1. Turn the engine power switch to the OFF position.
2. Turn the fuel valve to CLOSED position.
3. Turn off the water supply. Depressurize the system by squeezing the trigger until the water stops flowing.
4. Flip the safety lock to the locked position.
5. Unplug all hoses.

Emergency Stop (All Models)

1. To stop the engine in an emergency, turn the power switch OFF immediately.

NOTE

- Make sure the fuel valve and engine switch are in the OFF position when stopping, transporting, and storing the pressure washer.

6. USING YOUR PRESSURE WASHER

⚠ DANGER! ⚠

NEVER direct the water flow at people. The high pressure jet can be dangerous if misused and must not be directed at people, animals, electrical devices or the unit itself. **DO NOT TREAT FLUID INJECTION AS A SIMPLE CUT!** Seek medical help immediately.

⚠ WARNING!

Do not run the pump without connecting to the water supply and turning the water on. Failure to do so could damage the pressure washer. Failure to follow these instructions will void product warranty.

Water that passes through this unit is not safe to drink.

NOTE

- DO NOT allow the unit to run for more than 2 minutes without pulling the trigger to release water pressure. This could cause overheating and damage to the pump. When the temperature inside the pump gets too high the thermal relief valve will temporarily open and release a spray of water from the pump to lower the internal temperature.

6.1. USING THE SPRAY WAND



1. Flip the safety up.
2. Pull back on the trigger to begin emitting water.
3. To stop water flow, release the trigger.

6.2. USING SPRAY NOZZLES

⚠ WARNING!



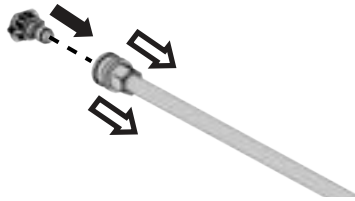

High pressure in nozzle area. Risk of injury caused by improperly locked nozzle.

When replacing nozzles with the engine running the trigger safety lock **MUST be engaged.**



To connect or disconnect a spray tip pull back on the quick connect collar. Insert or remove the spray tip then release the collar. Tug on the spray tip to ensure it is secured. The tips are color coded and stored on the panel.

Nozzle Selection Guide

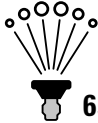
	 0°	 15°	 25°	 40°	 65°
Paint Stripping	✓	✓			
Concrete	✓	✓	✓		
Siding			✓	✓	✓
Deck			✓	✓	✓
Gutters			✓	✓	✓
Vehicles				✓	✓
Windows				✓	✓
Furniture				✓	✓
Detergent					✓

NOTE

- 0° RED nozzle – maximum pressure: outputs a very concentrated stream of water. This nozzle should be used for removing tough stains and debris from concrete and metal. **THIS NOZZLE WILL DAMAGE MOST SURFACES. DO NOT** use on wood, siding, decks, painted surfaces, windows, or vehicles.
- 15° YELLOW nozzle: used to prepare surfaces for painting. Can be used for surface preparation such as removing dirt, mildew, or paint from hard surfaces. **DO NOT** use on wood, windows, or vehicles.
- 25° GREEN nozzle: gentle lifting and cleaning for most surfaces. This nozzle is safe to use on most surfaces, attempt cleaning with this nozzle before using the YELLOW or RED nozzles. **DO NOT** use on windows or vehicles.
- 40° WHITE nozzle: safe to use on all surfaces including windows, blinds, and vehicles. This nozzle can be used for rinsing after using the soaping nozzle.
- 65° BLACK soaping nozzle: low pressure detergent nozzle. Use when applying detergents for your cleaning projects. Detergents will only be drawn from the detergent source when this nozzle is equipped.

Rinsing with the Pressure Washer

1. Test a small area first to avoid surface damage.
2. Rinse from top to bottom using long, overlapping strokes.

6.3 WORKING WITH DETERGENTS

NOTE

- Detergents will only be drawn from the detergent tank when using the black low pressure soap nozzle.
- Detergent will not be applied with the high pressure nozzles.
- DO NOT use bleach.

6.3.1 DETERGENT DILUTION

NOTE

- Dilution ratio:
 - BW3500: 1:25
 - BW3800: 1:25
 - BW4400: 1:25

The washer will draw 1 part detergent solution for every 25 parts water used. Use this to calculate the proper dilution ratio when combining your detergent and water in your detergent container. For example, if your detergent requires a dilution of 1:100, you should only dilute it with 4 parts water to 1 part detergent in the detergent container, before allowing the pressure washer to further dilute it to 1:100.

To Apply Detergent

BW3500

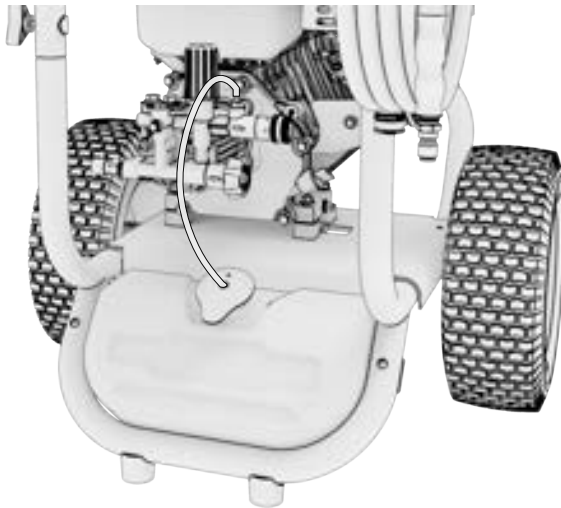

BW3800

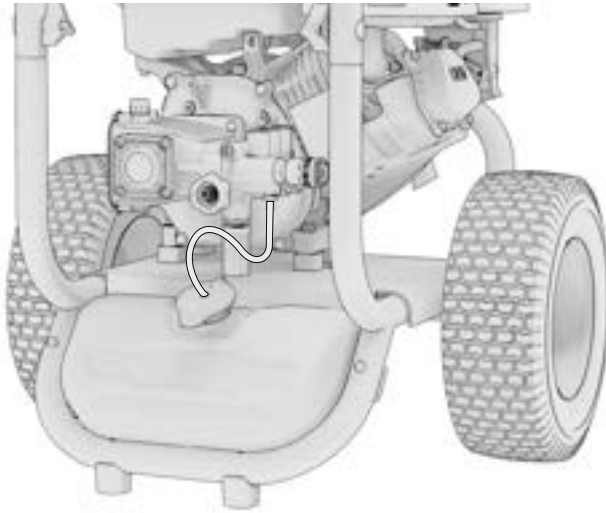

BW4400

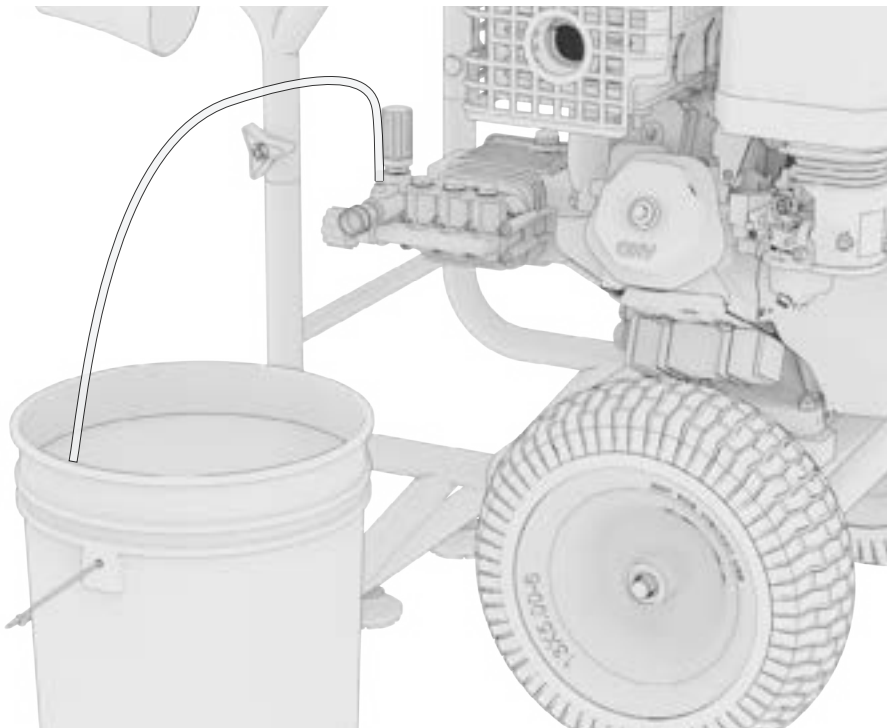

1. Install the black low pressure detergent nozzle.
2. Ensure the detergent siphon hose is connected from the detergent source to the water pump's detergent inlet.

3. Prepare the detergent, follow directions as supplied from detergent manufacturer.
4. Place the filter end into the built-in detergent tank (BW3500 and BW3800) or into the container with the detergent solution (BW4400).
5. With the engine running pull the trigger to operate the spray wand. Liquid detergent is drawn into the unit and mixed with water. Apply detergent to the work area. DO NOT allow the detergent to dry on the surface.
6. After using detergents, place the detergent siphon hose into a container of clean water and draw the clean water through the detergent injection system to rinse thoroughly. Remaining chemicals that dry in the system may cause damage. Damage caused by chemical residue will not be covered under warranty.

NOTE

- Only use mild, environmentally friendly detergents intended for use with pressure washers. Never use aggressive chemicals (like bleach), abrasive detergents, or similar to avoid damage to your health, the product, and the environment.

6.4 PRESSURE REGULATOR

The pressure is preset from the factory to optimize cleaning power and efficiency. If you need a lower pressure output you can:

- Stand further from the surface to be cleaned;
- Use a wider spray nozzle;
- Use the pressure regulator to further lower the pressure (BW3500 and BW4400 only). Turn the regulator counter-clockwise to lower to the desired pressure. To raise the pressure back to the factory setting turn the pressure regulator clockwise until it stops.

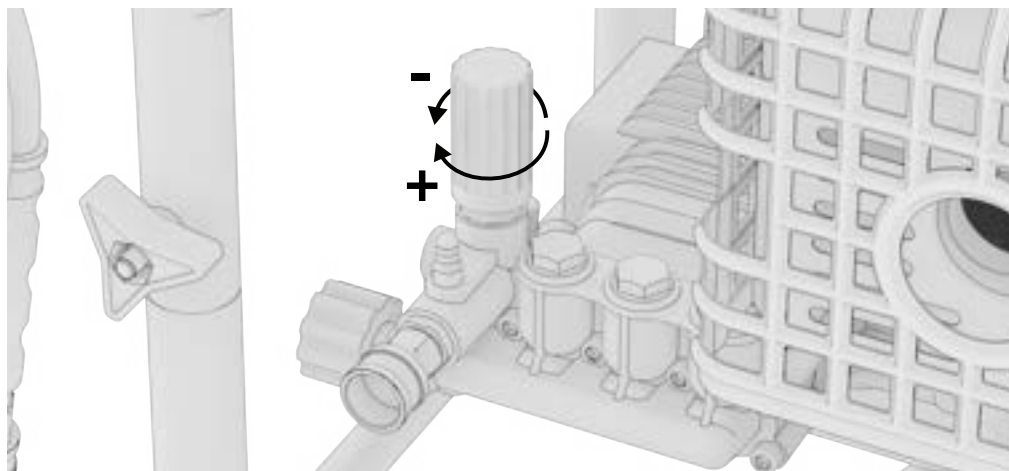

NOTE

- DO NOT try to turn the pressure regulator past the built in stop or damage to the pump may occur.
- DO NOT overtighten the regulator knob. This will result in an immediate loss of pressure and costly repairs to the unit.
- DO NOT attempt to increase the pressure above the factory setting. Attempting to do so will void your warranty and may damage the pump.

6.5 CARBURETOR MODIFICATION FOR HIGH ALTITUDE OPERATION (ABOVE 2,000 FEET)

NOTE

- This engine is equipped to run at altitudes below 2,000-ft.
- A high-altitude Main Jet is recommended when operated at 2,000 to 7,000-ft above sea level.
- At elevations above 7,000-ft the engine may experience decreased performance even with a high-altitude Main Jet.

At high altitudes the carburetor's air/fuel mixture becomes too rich, resulting in higher fuel consumption, lower performance, and carbon build-up on the spark plug. On the other hand, if the carburetor has been modified for high altitude operation and is operated below 2000-ft, the air/fuel mixture will then be too lean for low altitude use. Always use the correct Main Jet for your altitude.

The engine's carburetor, governor (if so equipped), and any other parts that control the air/fuel ratio will need to be adjusted by a qualified mechanic to allow efficient high-altitude use, and to prevent damage to the engine and any other devices used with this product. The fuel system on this engine may be influenced by operation at higher altitudes.

- Carburetor bowl may have gas in it which will leak upon removing the bolt.
- The mixing tube is held in place by the Main Jet and might fall out when it is removed. If it falls out, replace it in the same orientation before replacing the Main Jet.
- The Fuel Cup Seal and Bolt Seal may be damaged during removal and should be replaced with the new ones.

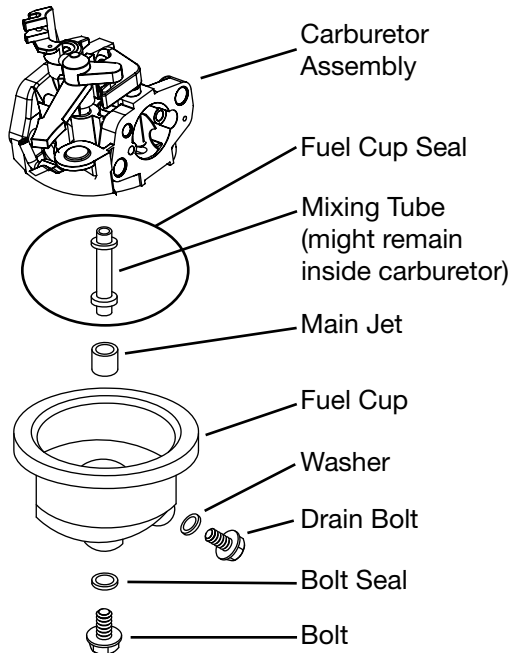

1. Turn off the engine.
2. Close the fuel valve.
3. Place a bowl under the fuel cup to catch any spilled fuel.
4. Unthread the bolt holding the fuel cup.
5. Remove the bolt, Bolt Seal, fuel cup, Fuel Cup Seal and Main Jet from the body of the carburetor assembly. A carburetor screwdriver (not included) is needed to remove and install the Main Jet.
6. Replace the Main Jet with the replacement Main Jet needed for your altitude range.
7. Replace the Fuel Cup Seal, fuel cup, Bolt Seal, and bolt. Tighten in place. Do not cross thread bolt when tightening. Finger tighten first and then use a wrench to make sure the bolt is properly threaded.
8. Wipe up any spilled fuel and allow excess to evaporate before starting engine. To prevent FIRE, do not start the engine while the smell of fuel hangs in the air.

7. MAINTENANCE

Proper maintenance keeps your pressure washer in the best operating condition by ensuring safe, economical and trouble-free operation. Only use genuine parts and recommended fluids to replace the worn components. Improper maintenance may cause the pressure washer to malfunction and can lead to serious injury. Contact customer support if you have any maintenance questions.

General Inspection Tips

- Look for fuel leaks around the fuel tank, fuel hose, and fuel valve. Close the fuel valve and repair leaks immediately.
- Look and listen for exhaust leaks while the engine is running. Have all the leaks repaired before continuing operation.
- Check for dirt and debris and clean as necessary .
- Check the engine oil level and add oil as necessary.

7.1 MAINTENANCE SCHEDULE

Maintain the pressure washer according to the maintenance schedule in this section.

NOTE

- Service more frequently when used in dusty areas.
- These items should be serviced by an authorized service center, unless you have the proper tools and are mechanically proficient. Refer to manual for service procedures.

Before Each Use
General inspection Check engine oil level Check pump oil level Inspect air filter
First 5 Hours
Change engine oil Change pump oil
Every 50 Hours
Check and clean air filter ¹ Check and clean sediment cup
Every 70 Hours
Change pump oil
Every 100 Hours or 12 Months
Change engine oil ² Inspect/clean spark plug Inspect/clean fuel line ¹
Every 300 Hours
Replace spark plug Replace air filter Clean combustion chamber ³ Inspect/adjust valve clearance ³ Clean fuel tank and strainer

¹ Replace if it cannot be adequately cleaned.

² Change oil after every 100 hours or yearly, whichever comes first. Service more frequently when operating under heavy load or in high temperatures.

³ Recommend service to be performed by authorized service dealer.

7.2 CHANGING THE ENGINE OIL

⚠ WARNING!

Used motor oil can cause skin irritations if left in long-term contact with skin. Thoroughly wash off used oil as soon as possible with soap and water.

Do not dispose of used oil in drains or on soil. Local service shops provide environmentally-friendly disposal methods.

Drain the oil rapidly and completely on a level surface while the engine is still warm.

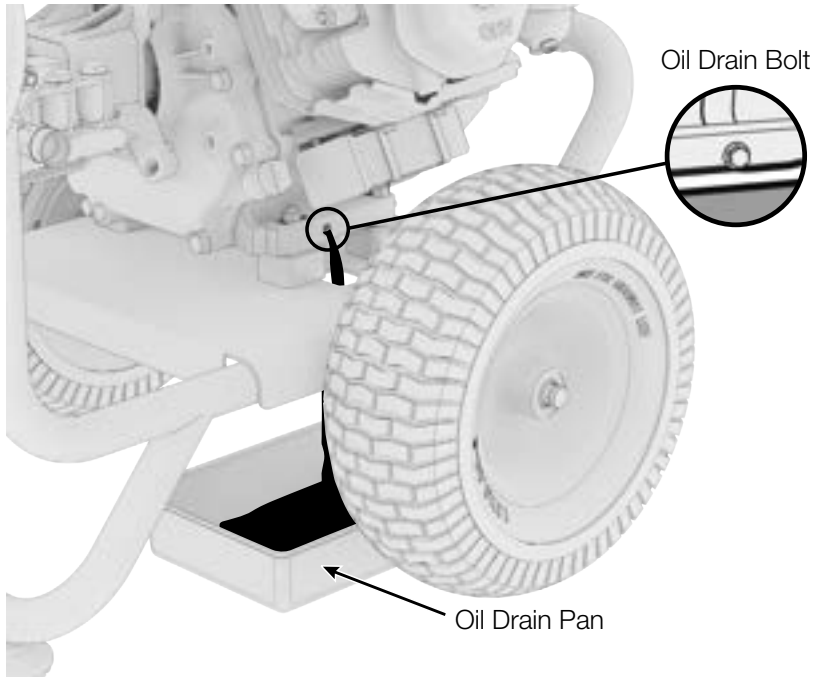

1. Stop the engine and remove oil filler dipstick.
2. Place a pan under the engine to catch the oil.
3. Remove the oil drain bolt and allow the oil to completely drain into the pan by tilting the pressure washer back and to the side to empty the oil from the crankcase.
4. Return the pressure washer to a level position and reinstall drain bolt. Fill the engine with fresh oil (SAE 10W-30 4 Cycle Engine Oil) up to the maximum mark on the dipstick *without* threading it back in. Do not overfill oil reservoir. Use a funnel to prevent spillage.
5. Reinstall the oil filler dipstick and tighten.

NOTE

- Oil max. capacity:
 - BW3500: 600 mL
 - BW3800: 700 mL
 - BW4400: 1.1 L
- SAE10W-30 oil is recommended for general use.
- DO NOT OVERFILL.

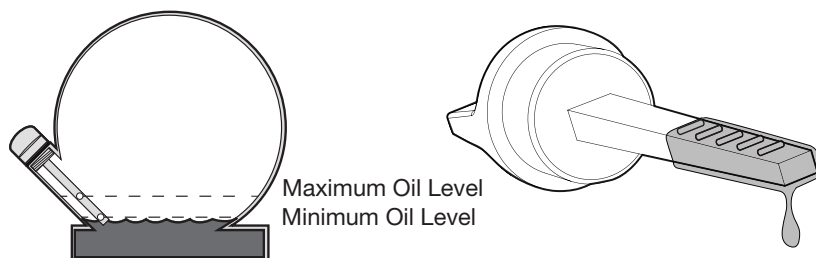
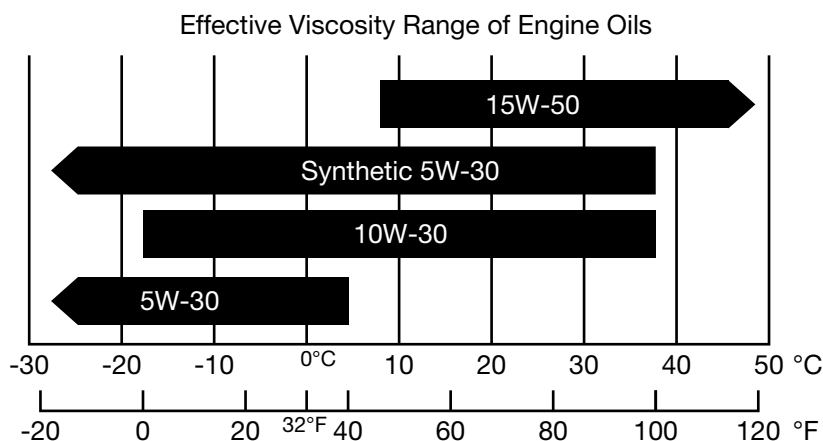

NOTE

- Do not tilt the pressure washer when adding engine oil. This could result in overfilling and damage to the engine.
- Use high quality engine oil with strong detergents. Using non-detergent or 2-stroke oil could shorten the engine's working life.
- Handle and store engine oil with care, avoid getting dirt or dust into the oil.
- Do not mix different engine oils.
- Before the engine oil falls below a safe level, the low oil alert system will automatically shut off the engine. The low oil light will turn on.
- To avoid the inconvenience of unexpected engine shutoff, check the engine oil level as often as possible.

- Use 4-stroke engine oil, certified to meet or exceed API standard SG, SF, SAE ratings.

7.3 CHANGING THE PUMP OIL

The triplex pump comes pre-filled with pump oil. Refill with an SAE 15W-40 oil, or if that is not readily available use pressure washer specific pump oil such as Annovi AR64516.

NOTE

- Pump oil capacity:
 - BW3500: 90 mL
 - BW3800: 300 mL
 - BW4400: 350 mL

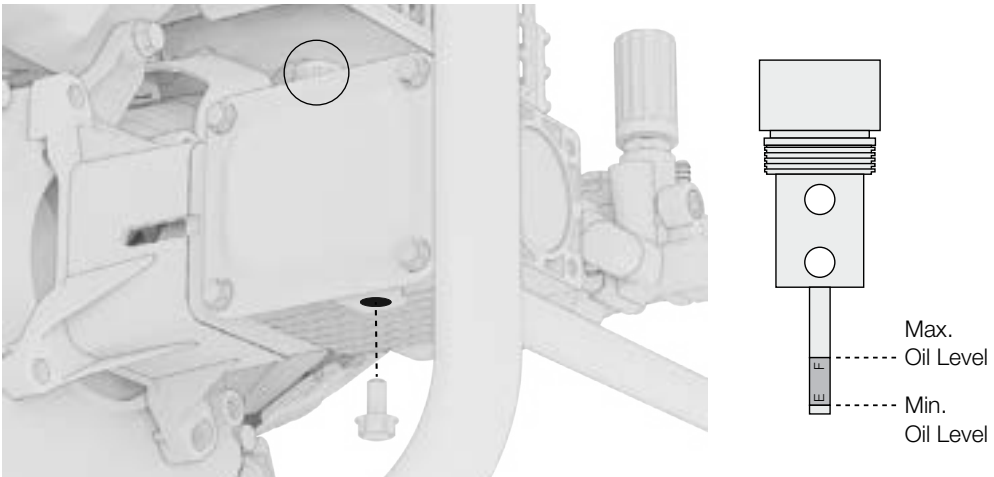

1. Loosen the pump oil dipstick located on top of the pump.
2. Place a container under the oil drain plug.
3. Remove the oil drain plug.
4. Wait for oil to drain out, replace pump oil drain plug and tighten.
5. Refill pump with oil to the max line on the dipstick, a funnel is recommended. To accurately read the oil level insert the dipstick into the hole *without* threading it in.
6. Replace pump oil dipstick and tighten.

7.4 CLEANING THE AIR-FILTER

⚠ WARNING!

Using gasoline or other flammable solvents can cause fire or explosion. Do not operate this product without an air filter.

A dirty air filter will restrict air flow into the carburetor. Clean and maintain the air filter regularly, especially in dusty areas.

NOTE

- Never run the pressure washer without an air filter, doing so will quickly degrade the engine.

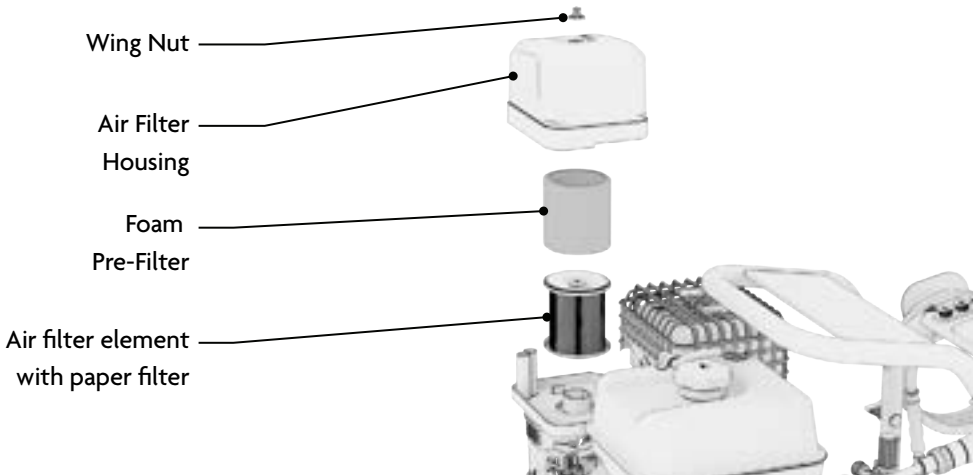

1. Loosen top nut and remove the air filter cover. Remove the air filter element.
2. Separate the *foam* pre-filter from the air filter element.
3. Inspect the *paper* filter inside the air filter element, shake filter or blow with air to remove any dust and debris. Replace either filter if damaged.
4. Clean the *foam* pre-filter with soap and water or solvent and let dry completely.
5. Wearing gloves, add new engine oil to the *foam* pre-filter. Work oil into *foam* filter until saturated.
6. Squeeze and repeatedly use a towel to pat out excess oil. The result should be a very lightly oiled pre-filter, if excess oil remains in the *foam* filter it can seep through to the *paper* filter and damage it.
7. Add *foam* pre-filter back to air filter element and reinstall onto engine.

7.5 NOZZLE CLEANING

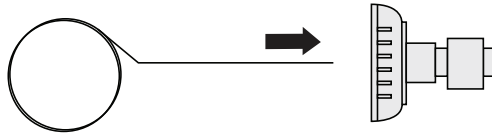

Detach the quick connect nozzle from the wand. Use a small wire such as a paper clip to gently loosen up any stuck particles in the nozzle. Flush with water.

7.6 CLEANING WATER INLET FILTER

Check the water inlet filter periodically and clean if necessary.

7.7 SPARK PLUG SERVICE

NOTE

- Do not rinse spark plug in water. Follow guidelines and be careful not to overtighten the spark plug.

Recommended spark plug: **F7TC**

Check the spark plug gap and clean the carbon deposits at the bottom of the spark plug.

Tighten 1/2 turn when installing a new spark plug.

Tighten 1/8 TO 1/4 turn when re-installing an old spark plug.

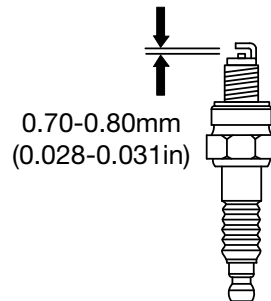
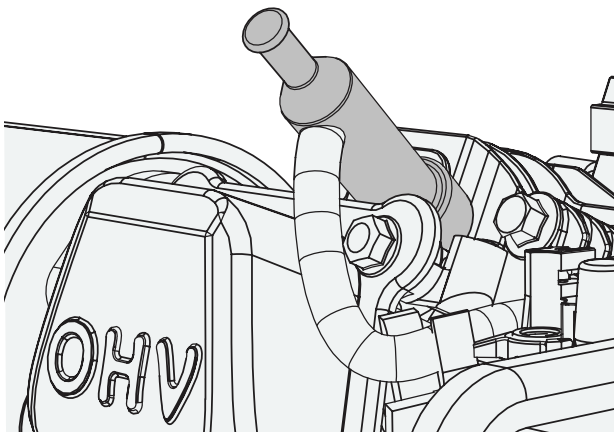

1. Remove the spark plug cap.
2. Remove the spark plug with the spark plug wrench.
3. Visually inspect the spark plug. Replace with a new plug if the insulation is cracked or chipped. Clean with a wire brush if the spark plug is reused.
4. Measure the spark plug gap with a feeler gauge. The normal value is: 0.7-0.8 mm (0.028- 0.031 in). Adjust the gap by carefully bending the electrode.
5. Carefully reinstall the spark plug by hand, to avoid cross-threading. A new spark plug should be tightened 1/2 turn with a spanner. A used spark plug should be tightened 1/8 to 1/4 turn with spanner.
6. Reinstall the spark plug cap.

NOTE

- The spark plug must be securely tightened or it could cause the spark plug to heat up, enough to damage the engine.
- Never use a spark plug with an improper heat range.

7.8 SPARK ARRESTER MAINTENANCE

1. After the engine has cooled down remove the bolts securing the muffler cover to the muffler.
2. Use a brush to remove carbon deposits from the spark arrester.

7.9 FUEL FILTER MAINTENANCE

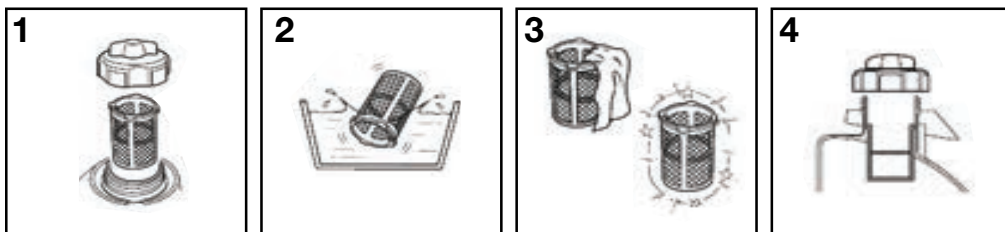

1. Remove the fuel cap and filter.
2. Clean the filter with solvent.
3. Wipe the filter.
4. Reinsert the filter.

7.10 EMISSION CONTROL SYSTEM

Emission Source

Exhaust gas contains carbon monoxide, nitrogen oxides (NOx) and hydrocarbons. It is very important to control the emissions of NOx and hydrocarbons as they are a major contributor to air pollution. Carbon monoxide is a poisonous gas. The emission of fuel vapors is a source of pollution as well. The pressure washer engine utilizes a precise air-fuel ratio and emission control system to reduce the emissions of carbon monoxide, NOx, hydrocarbons and evaporative fuel emissions.

Regulation

Your engine has been designed to meet current Environmental Protection Agency (EPA) clean air standards. The regulations dictate that the manufacturer provides operation and maintenance standards regarding the emission control systems. Tune up specifications are provided in the Specifications section and a description of the emission control system may be found in the appendix to this manual. Adherence to the following instruction will ensure your engine meets the emission control standards.

Modification

Modification of the emission control system may lead to increased emissions. Modification is defined as the following:

- Disassembling or modifying the function or parts of the intake, fuel or exhaust system.
- Modifying or destroying the speed governing function of the pressure washer.

Engine faults that may affect emission

Any of the following faults must be repaired immediately. Consult with your authorized service centre for diagnosis and repair:

- Hard starting or shut down after starting.
- Unstable idle speed.
- Shut down or backfire after applying an electrical load.
- Backfire or after fire.
- Black smoke and/or excessive fuel consumption.

Replacement parts and accessories

The parts making up the emission control system in your product's engine have been specifically approved and certified by the regulatory agencies. You can trust that the replacement parts supplied by customer service have been manufactured to the same production standard as the original parts. The use of replacement parts or accessories which are not designed for your engine – may negatively affect the engine emission performance. Therefore only use replacements parts and accessories from a qualified service centre to guarantee that the replacement products will not adversely affect emission performance.

Replacement parts other than those from an authorized service centre will void the warranty.

8. TRANSPORTATION & STORAGE

8.1 TRANSPORTING THE PRESSURE WASHER

Storage Duration	Preparation Required
Less than 1 Month	<ul style="list-style-type: none">■ No storage preparation required, simply store as is.
1 Month to 1 Year	<ul style="list-style-type: none">■ Drain the old gas and completely fill the tank with fresh gas before storage. Add fuel stabilizer according to the manufacturer's directions. Adding a quality fuel stabilizer can keep gas fresh for up to a year.
1 Year or More	<ul style="list-style-type: none">■ Drain off the gasoline from the fuel tank, and store in a suitable container. This will help prevent deposits from forming in the fuel system.■ Turn the fuel switch to OPEN and loosen the carburetor drain bolt. Take off the spark plug cap and revolve the engine 3 or 4 times, by pulling the recoil handle, to fully discharge the gasoline from the fuel lines.■ Turn the fuel switch to CLOSED and tighten the drain bolt of the carburetor.■ Change oil while engine is still warm from operation.■ Remove the spark plug, and pour a tablespoon of clean engine oil (10~20ml) into the cylinder. Revolve the engine several times by pulling on the recoil start to distribute the oil. Reinstall the spark plug. Pull the starter grip slowly until you feel resistance. At this point, the piston is coming up on its compression stroke and both the intake and exhaust valves are closed. This position helps to protect the engine from internal corrosion.

- Do not overfill the fuel tank (No residual fuel on the neck of tank).
- Avoid exposing the pressure washer to prolonged direct sunlight while in an enclosed vehicle. The high temperature inside the vehicle could cause fuel to vaporize resulting in a possible explosion.

- Drain the pressure washer of fuel and oil before being transported on rough roads.

8.2 DRAINING THE FUEL TANK

1. Turn OFF the engine. Remove the fuel cap and the debris screen underneath the fuel cap.
2. Empty the fuel tank using a siphon and an approved gasoline container.

8.3 DRAINING THE CARBURETOR

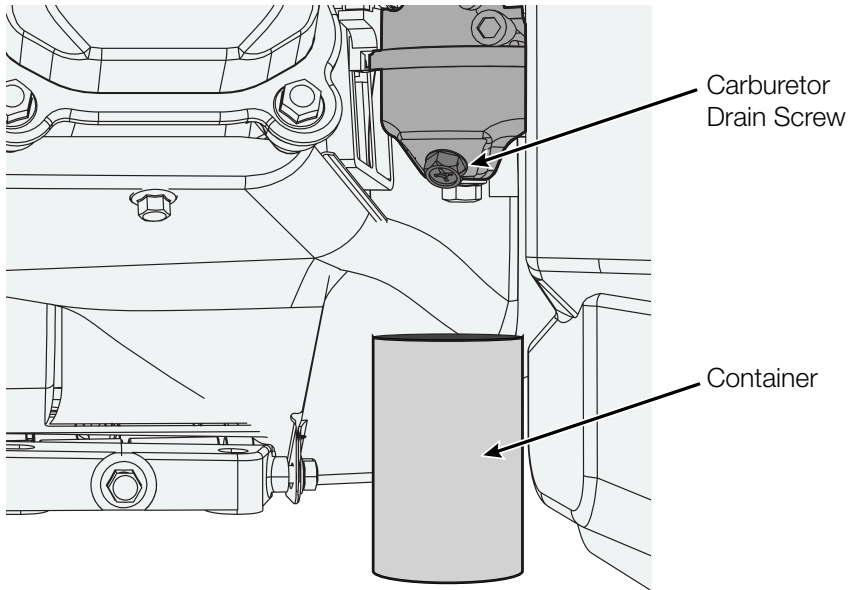

1. Turn OFF the engine and allow it to cool. Turn the fuel valve to OPEN.
2. Position a container under the carburetor drain screw. Loosen the drain screw.
3. Allow fuel to completely drain and re-tighten the drain screw.
4. Turn the fuel valve to CLOSED.

8.4 LONG TERM STORAGE - ENGINE

Before storing the pressure washer set for an extended period:

- Ensure that the storage area is free of excess humidity and dust.
- Drain the fuel tank and the carburetor.

8.5 LONG TERM STORAGE - PUMP

When storing your unit for more than 30 days, using a pressure washer pump guard (pump saver or pump winterizer) is recommended to keep seals lubricated, protect from rust, and prevent the pump from freezing damage.

NOTE

- DO NOT let water freeze inside the pump or hoses. The components may be permanently damaged.
 - Pump guard application may require two people.
1. Turn off pressure washer and disconnect all hoses.
 2. Connect the pump saver to the garden hose water supply inlet.
 3. Depress the button on top of the pump saver.
 4. With the ignition OFF, pull the starter rope and squeeze the bottle. Repeat until pump guard fluid exits the high pressure hose outlet.
 5. Remove the hose from the water supply inlet.

8.6 LONG TERM STORAGE - HOSES

1. Drain all water from the high pressure hose and wrap onto the holder.
2. Drain all water from the spray gun by holding it vertically with the nozzle down and squeezing the trigger until the water stops flowing.
3. Ensure the detergent siphon hose is drained and wrapped securely.

9. TROUBLESHOOTING

Problem	Possible Cause	Solution
Engine will not start	<ul style="list-style-type: none"> ■ No gasoline ■ Engine oil low ■ Choke is in the incorrect position ■ Water pressure built up after two recoil pulls ■ Spark plug cap disconnected ■ Fouled spark plug 	<ul style="list-style-type: none"> ■ Add fuel ■ Add engine oil ■ Move choke to the Start position ■ Squeeze the trigger after each failed recoil start to release the pressure ■ Connect spark plug cap ■ Replace spark plug
Engine hard to start	<ul style="list-style-type: none"> ■ Stale fuel or water in fuel 	<ul style="list-style-type: none"> ■ Drain fuel and refill with fresh gas
Engine lacks power and vibrates excessively	<ul style="list-style-type: none"> ■ Choke in the Start position ■ Dirty air filter 	<ul style="list-style-type: none"> ■ Move choke to the Run position ■ Clean air filter
Engine loses power when load is added	<ul style="list-style-type: none"> ■ Engine speed too low 	<ul style="list-style-type: none"> ■ Move throttle to full power (rabbit icon)
Not reaching high pressure	<ul style="list-style-type: none"> ■ Low pressure black detergent nozzle is attached ■ Low water supply ■ Water supply is restricted ■ Water inlet filter is clogged ■ Nozzle obstructed ■ High pressure hose is too long 	<ul style="list-style-type: none"> ■ Remove and attach a high pressure nozzle ■ Water supply must be from a 3/4" diameter hose minimum ■ Check hose for leaks, kinks, or blockages. Ensure the water supply tap is all the way open. ■ Remove filter and rinse in warm water. Reinstall. ■ See nozzle cleaning instructions ■ Max high pressure hose of 100 feet (30m)

<p>Detergent does not mix with water</p>	<ul style="list-style-type: none"> ■ Spray wand not in low pressure ■ Chemical screen not in cleaning solution ■ Chemical too thick 	<ul style="list-style-type: none"> ■ Remove and attach the black low pressure nozzle. Detergents will only be drawn at low pressure ■ Ensure end of detergent siphone hose is fully submerged into cleaning solution ■ Dilute chemical. It should look like the same consistency as water
<p>Inconsistent or low pressure during use</p>	<ul style="list-style-type: none"> ■ Water supply is restricted ■ Water supply not turned on full power ■ Nozzle is clogged ■ Spray gun leaks ■ Air in line ■ Inlet hose screen is clogged ■ Water supply temperature is over 100F ■ Pump is faulty 	<ul style="list-style-type: none"> ■ Inspect garden hose for kinks, leaks, or blockages. Use min. of 3/4" garden hose ■ Open water supply tap all the way ■ Clean nozzle ■ Check all connections. Use sealant tape if necessary ■ Squeeze trigger handle to remove air in line ■ Clean inlet filter in warm water ■ Use cool water supply ■ Contact technical support
<p>Water leaking at spray wand connection or pump</p>	<ul style="list-style-type: none"> ■ Loose connections ■ Worn spray wand o-ring ■ Piston packings worn ■ Worn pump o-ring ■ Pump head or tubes damaged from freezing 	<ul style="list-style-type: none"> ■ Tighten ■ Replace ■ Contact technical support

10. TECHNICAL SPECIFICATIONS

		BW3500	BW3800	BW4400
Pressure washer	PSI Max.	3500 PSI	3800 PSI	4400 PSI
	GPM Max.	2.8 gpm	3.5 gpm	4.0 gpm
	High Pressure Hose	30 ft. (9.1 m)	50 ft. (15.2 m)	50 ft. (15.2 m)
	Pressure of Inlet Water	30-100 PSI	30-100 PSI	30-100 PSI
	Inlet Water Temperature	Cold tap (38°C/100°F Max.)	Cold tap (38°C/100°F Max.)	Cold tap (38°C/100°F Max.)
	Detergent Consumption Rate	1:25	1:25	1:25
Engine	Type	7.0 HP, Single Cylinder, forced air cooling, 4-stroke, OHV	8.5 HP, Single Cylinder, forced air cooling, 4-stroke, OHV	15.0 HP, Single Cylinder, forced air cooling, 4-stroke, OHV
	Displacement (cm ³)	224cc	274cc	420cc
	RPM	3400-3600	3400-3600	3400-3600
	Fuel tank capacity (Gal)	3.6 L / 1 Gal	5 L / 1.3 Gal	6.5 L / 1.7 Gal
	Oil capacity	600 mL / 20 oz. (10W30)	700mL / 24 oz. (10W30)	1.1 L / 37 oz. (10W30)
	Fuel Type	Unleaded gasoline 87+ Octane	Unleaded gasoline 87+ Octane	Unleaded gasoline 87+ Octane
Unit	L x W x H	34 x 24 x 28	34 x 24 x 28 in	21.5 x 21.5 x 39 in
	Gross Weight	81.4 lbs	101.4 lbs	146 lbs

11. LIMITED WARRANTY

This product is distributed by:

Midland Power Inc.

376 Magnetic Drive, Toronto, ON M3J 2C4, Canada

Warranty

Beginning at the time of retail purchase and for the duration of the warranty period Midland Power Inc. (Midland) warrants that Equipment manufactured by it is warranted to be free from defects in material and workmanship. Midland will, at its sole discretion, replace or repair any part(s) which, upon evaluation and testing by Midland or an authorized service center, show a defect in workmanship or material. Valid proof of purchase must be submitted online for registration with Midland, or presented to Midland at time of claim, for warranty to be valid. This warranty is not transferable from the original owner.

Limited Warranty Period:

Non-commercial use:

- Year 1, 2 and 3 - Parts and Labour
- Year 4 and 5 - Parts

Commercial use:

- First 6 Months - Parts and Labour

Replacement parts sold to a consumer or installed by an authorized service center are warranted for a period of 90 days from date of purchase. Labour must be performed by an authorized service center unless given Midland's prior written approval. Midland will not bear any transportation or shipping fees to or from an authorized service center. Service calls, travel charges, overtime, or weekend rates, are not covered.

This warranty does NOT cover:

- a. Any repairs required as a result of any parts not supplied by Midland, and this part is responsible for the failure or malfunction;
- b. Any Equipment modified, altered, disassembled or remodelled;
- c. Any repairs required as a result of a failure to install, maintain, store, transport, or operate the Equipment in accordance with standard practices set out in the user guide;
- d. Damage that occurred after receipt of equipment, not caused by defects in workmanship or material;
- e. Normal maintenance services, as outlined in the user guide and intended for a consumer to perform;

- f. Replacement of parts made in connection with normal maintenance services including oils, adhesives, additives, fuel, filters, brushes, belts, lubricants, spark plugs, gaskets, seals, fasteners, wires, tubes, pipes, fittings, wheels, batteries, and other expendables susceptible to natural wear;
- g. Any accessory or attachment.

Any battery supplied with this Equipment is considered a consumable item and is excluded from this warranty. Batteries can be damaged by shock, shorting terminals, heat, acid spillage, neglect, and other factors. It is the customer's responsibility to take great care when handling a battery so no spillage of acid occurs which may cause corrosion.

Midland disclaims any responsibility for loss of time or use of the product, transportation, or towing costs or any other indirect, incidental, or consequential damage, inconvenience or commercial loss.

This warranty is the entire and only warranty given by Midland for Midland products or equipment. No agent or employee is authorized to extend or enlarge this warranty on behalf of Midland by any written or verbal statement or advertisement.

California

The California Air Resources Board and Midland Power Inc. are pleased to explain the emission control system warranty on your Midland Power Inc. engine. In California, new spark-ignited small off-road equipment engines must be designed, built, and equipped to meet the State's stringent anti-smog standards.

Other States, U.S. territories, and Canada

In other areas of the United States and in Canada, your engine must be designed, built, and equipped to meet the U.S. EPA and Environment Canada emission standards for spark-ignited engines at or below 19 kilowatts.

All of the United States and Canada

Midland Power Inc. must warrant the emission control system on your power equipment engine for the period of time listed below, provided there has been no abuse, neglect, or improper maintenance of your power equipment engine. Where a warrantable condition exists, Midland Power Inc. will repair your power equipment engine at no cost to you including diagnosis, parts, and labor.

Your emission control system may include such parts as the carburetor or fuel injection system, the ignition system, and catalytic converter. Also included may be hoses, connectors, and other emission-related assemblies.

Emission Control System Warranty Parts:

This list applies to parts supplied by Midland Power Inc. and does not cover parts supplied by the equipment manufacturer. Please see the original equipment manufacturer's emissions warranty for non-Midland Power Inc. parts.

Consumable parts are covered up to a maximum of 30 days.

SYSTEMS COVERED IN WARRANTY	PARTS DESCRIPTION
Fuel Metering	Carburetor assembly (includes starting enrichment system), Engine temperature sensor, Engine control module, Fuel regulator, Intake manifold
Evaporative	Fuel Tank, Fuel Cap, Fuel Hoses, Vapor Hoses, Carbon Canister, Canister Mounting Brackets, Fuel Strainer, Fuel cock, Fuel Pump, Fuel Hose Joint, Canister Purge Hose Joint
Exhaust	Catalyst, Exhaust Manifold
Air Induction	Air filter housing, Air filter element
Ignition	Flywheel magneto, Ignition pulse generator, Crankshaft position sensor, Power coil, Ignition coil assembly, Ignition control module, Spark plug cap, Spark plug
Crankcase Emission Control	Crankcase breather tube, Oil filler cap
Miscellaneous Parts	Tubing, fittings, seals, gaskets, and clamps associated with these listed systems

BENCHMARK[™]

**MIDLAND
POWER** 

Customer Service

Online: www.benchmark.midlandpowerinc.com

E-mail: support@midlandpowerinc.com

Toll Free: 1-877-528-3772

Enjoy!

Be sure to check www.benchmark.midlandpowerinc.com for updates regarding your product.





BENCHMARKTM_{MC}
BW SERIES