

Radley®

RW3200

# Pressure Washer

## User Guide



# Radley

The engine exhaust from this product contains chemicals known to cause cancer, birth defects or other reproductive harm.

©2021 Radley. All Rights Reserved.

RW3200\_UG\_EN\_2021-09-21

**Thanks for choosing the RW Series!**

Let's get started!

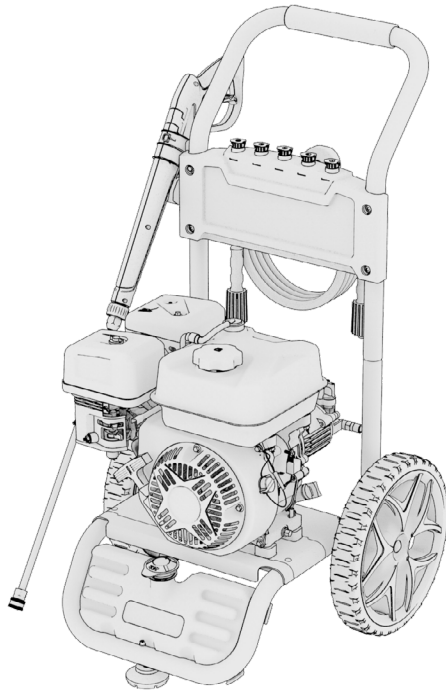

THIS PRODUCT MEETS ALL CERTIFICATION REQUIREMENTS FROM:





## **WE'VE GOT YOU COVERED!**

Do not return product to store.

Email us at [support@midlandpowerinc.com](mailto:support@midlandpowerinc.com) or contact us by phone at **1-877-528-3772** if you have any questions.

## **SAVE THESE INSTRUCTIONS**

This user guide contains important instructions for your product, that should be followed during installation and maintenance of the pressure washer.

This user guide covers the safety, operation and maintenance procedures for the RW3200.

All information in this publication is based on the latest product information available at the time of print.

No part of this publication may be reproduced without written permission.

## **WARRANTY INFORMATION**

Online: **[radley.midlandpowerinc.com](http://radley.midlandpowerinc.com)**

Email: **[support@midlandpowerinc.com](mailto:support@midlandpowerinc.com)**

Phone: **1-877-528-3772**

Warranty support, operation assistance and product support is provided by Midland Power Inc., a licensed manufacturer of Radley Pressure washers. Please contact us directly for any warranty service questions.

See 'Limited Warranty' for more information.



Product registration is required for product support and warranty coverage. You can register online at [radley.midlandpowerinc.com](http://radley.midlandpowerinc.com). Once your registration is complete, your receipt will be on file and any future warranty claims will be easily created.



## TABLE OF CONTENTS

<b>1. Safety</b>	<b>1</b>
<b>2. Learn About Your Pressure washer</b>	<b>5</b>
2.1 Component Identification	5
2.2 Assembly Instructions	6
<b>3. Pre-Operation Check</b>	<b>8</b>
3.1 Prepare the Air Filter	8
3.2 Add Engine Oil	9
3.3 Add Fuel	11
3.4 Check the Cold Water Supply	12
3.5 Assemble the Spray Wand and Hoses	13
<b>4. Starting your Pressure washer</b>	<b>16</b>
4.1 Recoil Engine Start	17
4.2 Stopping the Pressure Washer	19
<b>5. Pressure washer Operation</b>	<b>20</b>
5.1. Using the Spray Wand	20
5.2. Using the Spray Nozzles	21
5.3 Working with Detergents	23
5.4 Detergent Dilution	24
5.5 Carburetor Modification for High Altitude Operation	24
<b>6. Maintenance</b>	<b>25</b>
6.1 Maintenance Schedule	26
6.2 Changing the Engine Oil	27
6.3 Pump Oil	28
6.5 Nozzle Cleaning	30
6.6 Cleaning Water Inlet Filter	30
6.7 Spark Plug Service	30
6.8 Spark Arrester Maintenance	31
6.9 Fuel Filter Maintenance	32
6.10 Emission Control System	32
<b>7. Transportation &amp; Storage</b>	<b>34</b>
<b>8. Troubleshooting</b>	<b>37</b>
<b>9. Technical Specifications</b>	<b>39</b>
<b>10. Limited Warranty</b>	<b>40</b>

# 1. SAFETY

<b>⚠ DANGER</b>	
Using a generator indoors <b>CAN KILL YOU IN MINUTES</b> . Generator exhaust contains carbon monoxide. This is a poison you cannot see or smell.	
	
NEVER use inside a home or garage, <b>EVEN IF</b> doors and windows are open.	Only use <b>OUTSIDE</b> and far away from windows, doors, and vents.
Avoid other generator hazards. <b>READ MANUAL BEFORE USE.</b>	

## **⚠ DANGER! ⚠**

**Using a gas powered pressure washer indoors can kill you in minutes.**

**The engine exhaust from this product contains chemicals known to cause cancer, birth defects or other reproductive harm.**

## 1.1 OPERATOR SAFETY

### **⚠ WARNING!**

- Always perform an oil, fuel and air filter check before starting the engine.
- Properly clean and maintain the equipment.
- Operate the pressure washer according to instructions for safe and dependable service.
- Before operating the pressure washer, read the user guide carefully. Otherwise, personal injuries or equipment damage may result.
- Never run the pressure washer in an enclosed area to avoid harm from exhaust emissions of a poisonous carbon monoxide gas.
- Be careful not to touch the exhaust system during operation due to risk of burns.
- Pay attention to the warning labels. The engine exhaust system will become heated during operation and remain hot immediately after the engine is stopped.
- Gasoline is a highly flammable and explosive liquid. Refuel in a well ventilated area with the engine stopped.
- Use of gasoline with an ethanol content greater than 10% can damage the engine and fuel system and will void the manufacturer's warranty.
- When refueling the pressure washer, keep it away from cigarettes, open

flames, smoke and/or sparks.

- Place the pressure washer at least 3 feet away from buildings or other equipment during operation.
- Run the pressure washer on a level surface. Tilting the pressure washer may result in fuel spills.
- Know how to stop the pressure washer quickly and understand operation of all the controls. Never permit anyone to operate the pressure washer without proper instructions.
- Keep children, pets and machinery with rotating parts away during operation.
- Do not operate the pressure washer in rain or snow.
- Do not touch the spark plug while the engine is operating or shortly after the engine has been shut down.
- Wear ear and eye protection while operating this unit.

## 1.2 USE SAFETY

### **WARNING!**

- NEVER direct the water spray towards electrical wiring, devices, or directly at the pressure washer itself. Fatal electric shock may occur.
- NEVER direct the water flow at people. The high pressure jet can be dangerous if misused and must not be directed at people, animals, electrical devices or the unit itself. **DO NOT TREAT FLUID INJECTION AS A SIMPLE CUT!** Seek medical help immediately.
- NEVER spray flammable liquids, risk of explosion. Operate only where open flame or torch is permitted.
- Always operate on dry, solid level ground.
- DO NOT expose this product to excessive moisture, dust, or dirt.
- DO NOT use in areas where fumes from paint solvents or flammable liquids pose a potential hazard.
- Inspect before each use, ensure all nuts, bolts, screws, hydraulic fittings, hose clamps, wheels, etc. are securely tightened. Always check the oil level before operating. Never operate when the product is in poor mechanical condition.
- Never move this product while spraying.
- DO NOT run the engine when you are not using the product.
- DO NOT use acids, solvents, alkaline, or flammable substances in this product. They may cause injuries to the operator and will permanently damage the machine.

- Only use detergents that are designed to be specifically used with a pressure washer. The user of other cleaning detergents may void the warranty.
- The spray gun will kick, hold with both hands.
- Never run the unit dry, always be sure the water supply is turned on fully before operating the unit.
- Know how to stop the product and bleed pressure quickly. Be thoroughly familiar with the controls.
- DO NOT operate the pressure washer without the water turned on.
- DO NOT overreach or stand on unstable surface. Keep good footing and balance at all times.
- Wear proper eye and ear protection while operating.

### 1.3 MAINTENANCE SAFETY

#### **⚠ WARNING!**

- Turn off the engine before performing any maintenance. Failure to do so can cause severe personal injury or death.
- Before performing maintenance depressurize the unit by turning off the water supply and squeezing the trigger of the spray wand until water stops flowing.
- Use rubber gloves when coming into contact with engine oil.
- After any maintenance is performed, wash immediately using soap and clean water because repeated exposure to lubricant may cause skin irritation.
- Do not clean the filter element with flammable liquids like gasoline because an explosion may occur.
- Allow the pressure washer set to cool down before performing any maintenance.
- Do not spray the pressure washer itself.
- Always stop the pressure washer set before removing the oil filler cap.
- Only qualified maintenance personnel with knowledge of fuels and machinery hazards should perform maintenance procedures.
- DO NOT let water in the pump freeze. See the storage section for further details on how to store properly during the winter.
- See 'Maintenance Schedule' for the recommended maintenance schedule.

## 1.4 OTHER SAFETY TIPS

**⚠ WARNING ⚠**  
**AVERTISSEMENT**

 **TOXIC FUMES HAZARD.** Running engines give off carbon monoxide, an odourless poisonous gas that can cause nausea, fainting, or death. Do not start engine indoors or in an enclosed area, even if the windows and doors are open.

**DANGER TOXIQUE.** Faire fonctionner un moteur dégage de l'oxyde de carbone, un gaz inodore toxique qui peut provoquer la nausée, évanouissement ou la mort. Ne démarrer pas le moteur à l'intérieur ou dans une espace clos, meme si les fenêtres et les portes sont ouvertes.

### **⚠ WARNING!**

- Running engines give off carbon monoxide, an odourless poisonous gas that can cause nausea, fainting, or death. Do not start engine indoors or in an enclosed area even if the windows and doors are open.
- If you start to feel sick, dizzy, or weak after the pressure washer has been running, move to fresh air **RIGHT AWAY**. See a doctor. You could have carbon monoxide poisoning.
- Pressure washers vibrate in normal use. During and after the use of the pressure washer, inspect the pressure washer as well as hoses connected to it for damage resulting from vibration. Have damaged items repaired or replaced as necessary. Do not use hoses that show signs of damage such as broken or cracked insulation or damaged connectors.

## 2. LEARN ABOUT YOUR PRESSURE WASHER

This section will show you how to identify key parts of your pressure washer. Going over the terminology below will make sure we're on the same page.

### 2.1 COMPONENT IDENTIFICATION

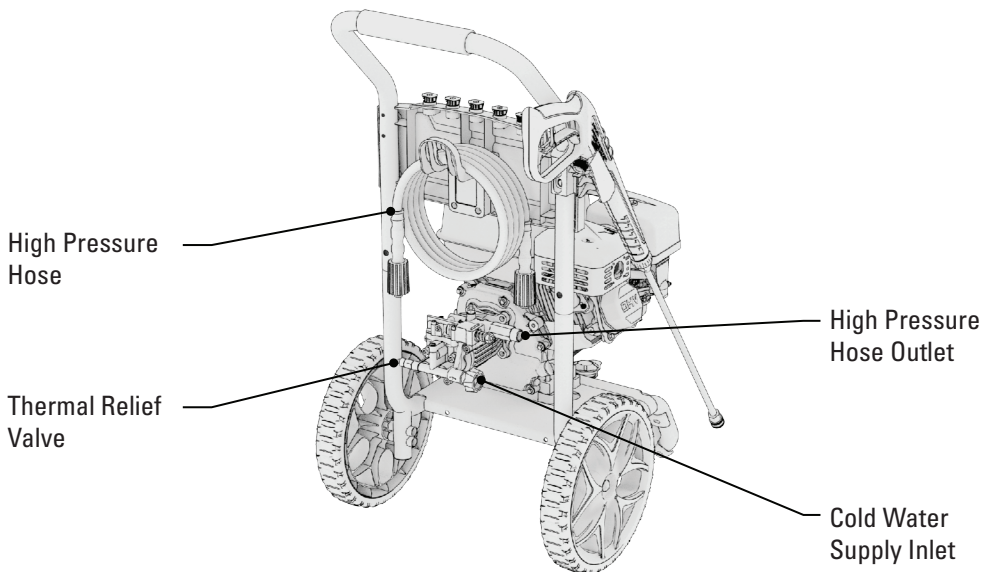
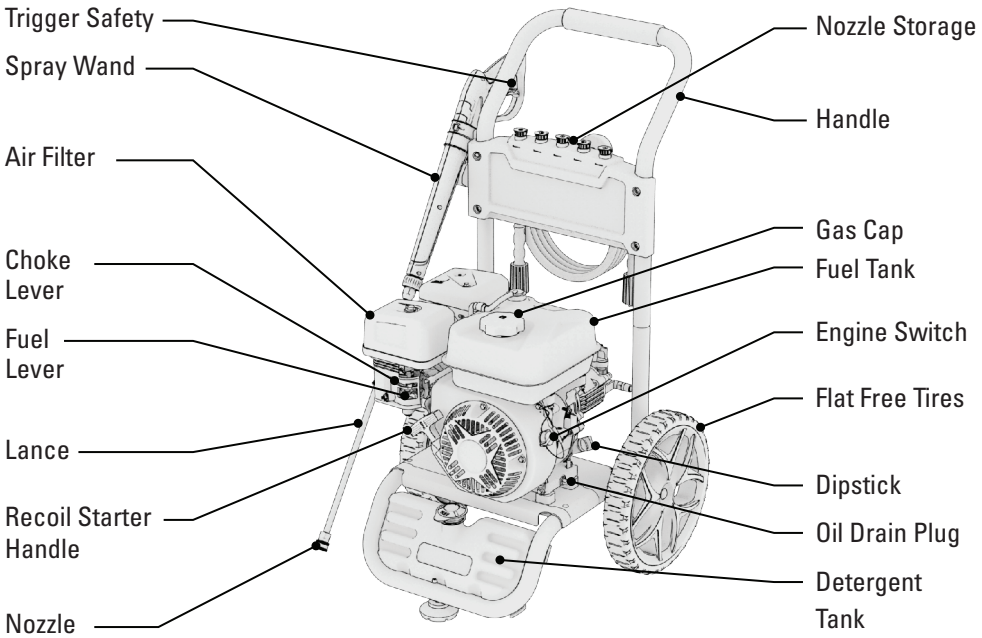



## 2.2 ASSEMBLY INSTRUCTIONS

Setup of your pressure washer is designed to get you up and running as quickly as possible.

### Assembling the Wheels

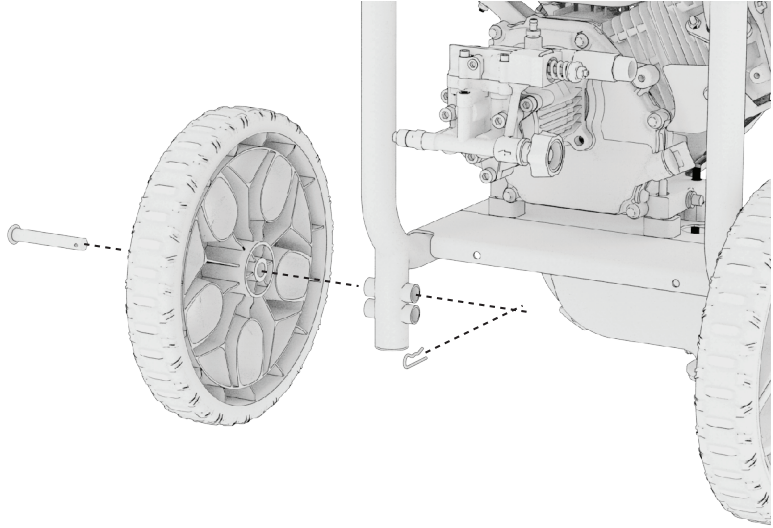

1. Place a piece of cardboard down to protect the frame and tip the pressure washer onto its side.
2. Insert the axle pin through the wheel and the frame.
3. Insert the cotter pin through the axle to lock it in place.
4. Repeat for second wheel.

### Installing the Foot

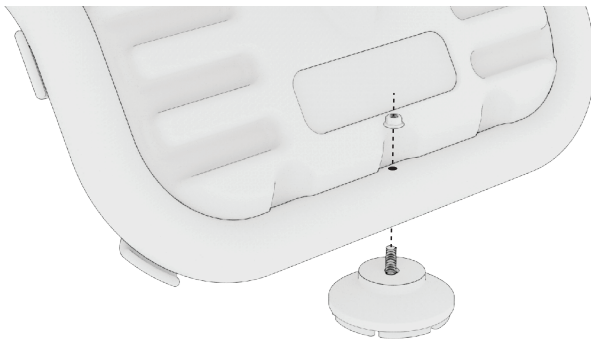

1. Secure the foot onto the frame by tightening the bolt onto the nut.

## Installing the Handle

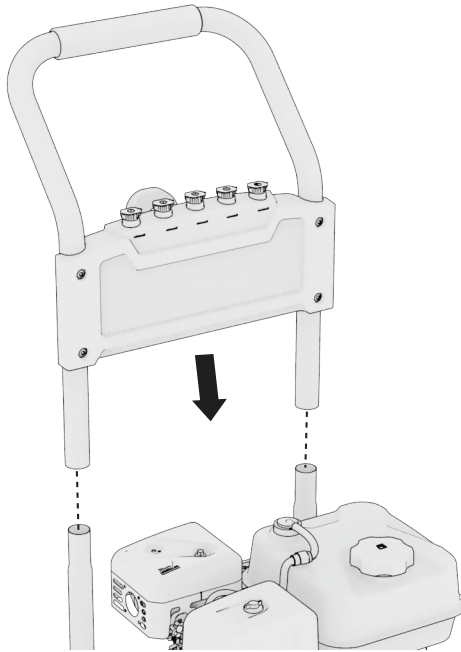

1. Locate the handle in place and let it slide down to the pins.
2. Press the pins in while pressing down on the handle until it snaps into place.

## Spray Gun Holder

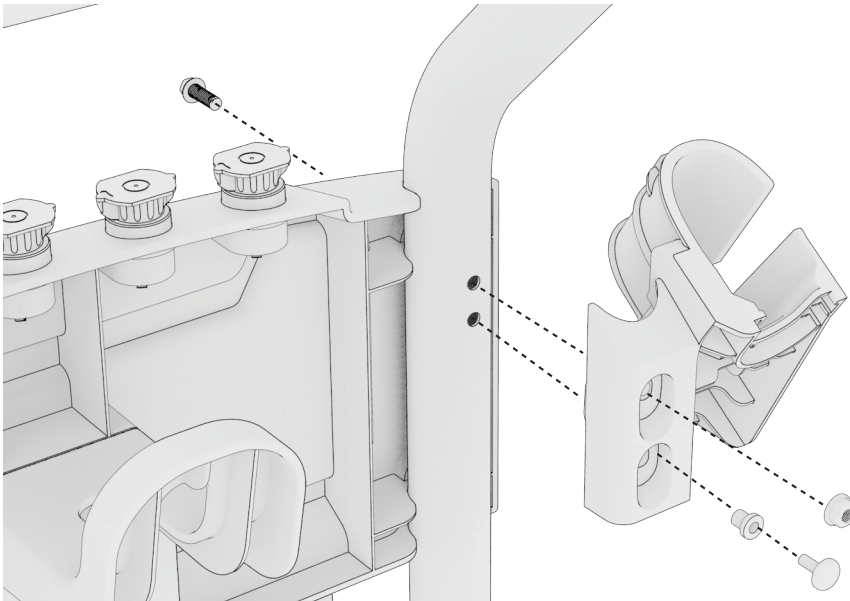

1. Attach spray gun holder to the frame with the fasteners provided.

### 3. PRE-OPERATION CHECK

These quick checks should be done each time the pressure washer is started to ensure you get the most out of your pressure washer.

Set the pressure washer on a level surface and the power switch to OFF.

#### **⚠ WARNING!**

**Exhaust gas contains poisonous carbon monoxide. Never run the pressure washer in an enclosed area. Be sure to provide adequate ventilation. Operate the pressure washer on a level surface. If the pressure washer is tilted, fuel spillage may result. Keep away from rotating parts while the pressure washer is running. The pressure washer is air-cooled and may be damaged if ventilation is inadequate.**

#### 3.1 PREPARE THE AIR FILTER

Check the air filter before your first use. Check the maintenance schedule for a complete cleaning guide.

Loosen the knob and remove the air filter cover. Remove the air filter element and inspect for cleanliness.

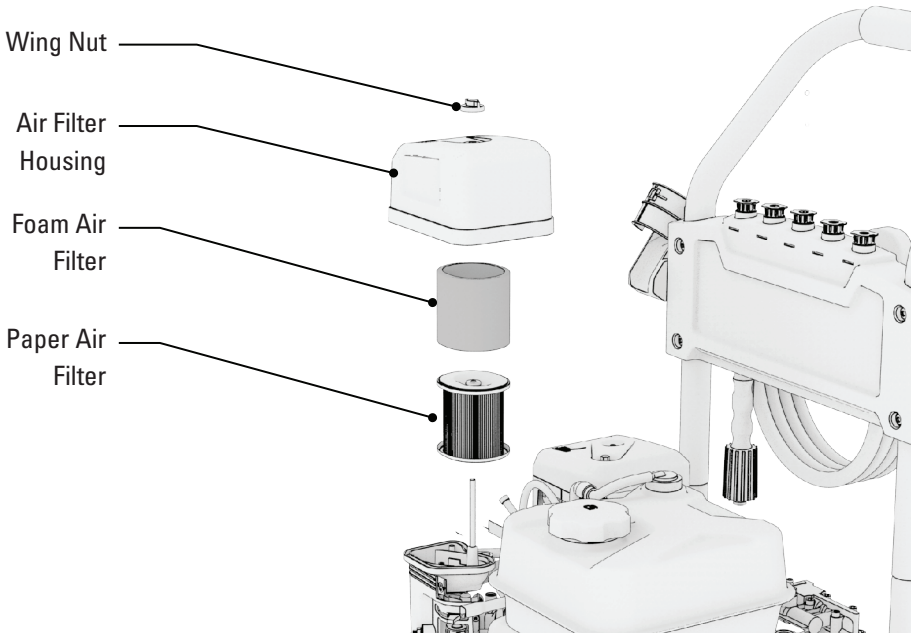

1. Loosen the nut and remove the air filter cover. Remove the air filter housing and elements and inspect for cleanliness.
2. Gently shake the *paper* filter or blow with air to remove the dust and debris.

3. Clean the *foam* air filter with soap and water or solvent and let dry.
4. Soak the *foam* filter in clean engine oil.
5. Gently squeeze and then pat out all excess oil and reinstall. If excess oil remains in the foam filter it can seep through to the paper filter and damage it.
6. Replace either filter if it is damaged.

#### Note

- Running the engine without the air filter will quickly degrade the engine
- Always inspect air filter before using the pressure washer. Check and clean the air filter according to the maintenance schedule.

## 3.2 ADD ENGINE OIL

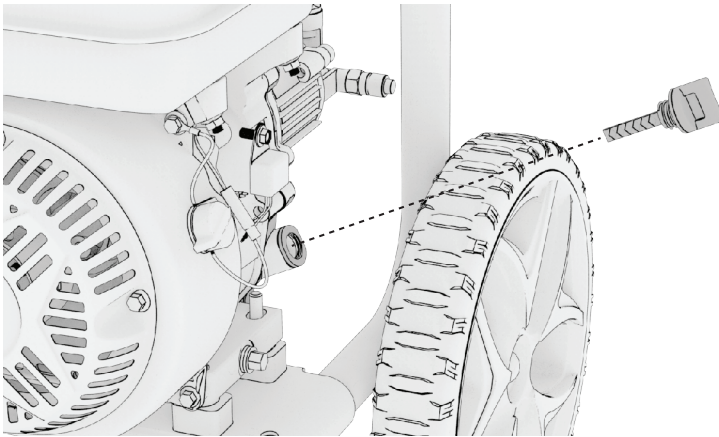

1. Ensure the pressure washer is on a level surface.
2. Unscrew one oil dipstick and clean the dipstick.
3. Check the oil level by reinserting the oil dipstick without screwing it back in. Remove the dipstick and examine the oil level. If the level is at or below the minimum oil level marked on the dipstick, refill to the maximum oil level mark using a funnel.
4. Reinsert the dipstick and tighten securely.

#### Note

- Max. oil capacity: 600mL
- SAE 10W-30 is recommended for general use.
- Do not tilt the pressure washer when adding engine oil. This could result in overfilling and damage to the engine.
- Using non-detergent or 2-stroke oil could shorten the engine's working life.

- Use high quality engine oil with strong detergents.
- Handle and store the engine oil with care, avoid getting dirt or dust into the engine oil.
- Do not mix different engine oils.
- To avoid the inconvenience of unexpected engine shutoff, check the engine oil level as often as possible.
- Use 4-stroke engine oil, certified to meet or exceed API standard SG, SF, SAE ratings

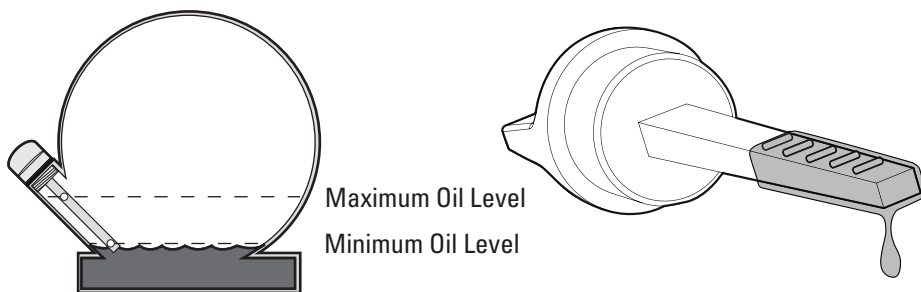
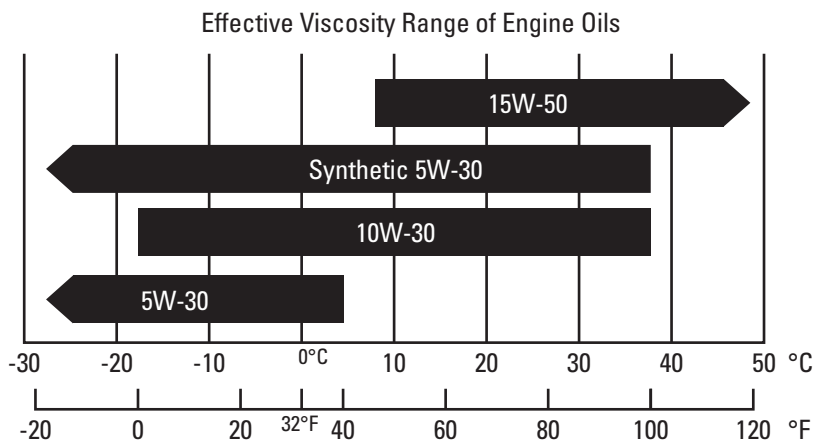

### 3.2.1 PUMP OIL

This unit has a sealed pump which ships filled with oil from the factory. There is no need to add or change the pump oil.

### 3.3 ADD FUEL

#### **⚠ WARNING!**

**Gasoline is highly flammable and explosive under certain conditions. Refuel in a well-ventilated area with the engine stopped. Do not smoke or allow open flames or sparks in the area where the pressure washer is being refueled or where gasoline is stored. Do not overfill the tank. Be careful not to spill fuel when refueling. Wipe up any spilled gasoline and let the area dry before starting the engine.**

**Gasoline substitutes such as gasohol are not recommended. They may be harmful to the fuel system components.**

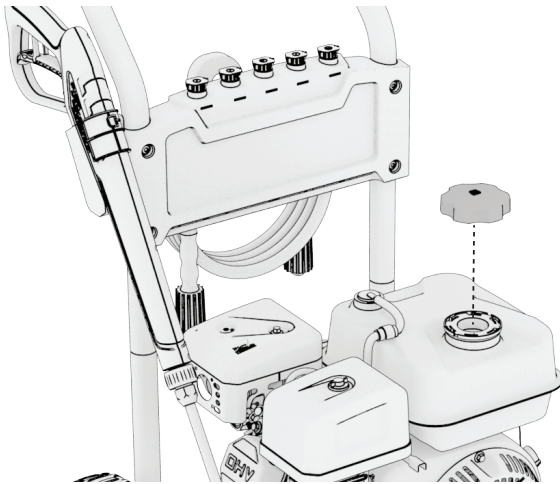

1. Check the fuel level by removing the fuel tank cap to visually check the level.
2. Add fuel until the level reaches 1.5" below the top of the neck. Tighten the fuel cap securely after refilling.

#### **Note**

- Only use unleaded gasoline (Pump Octane 87 or higher).
- Never use stale or contaminated gasoline, or an oil/gasoline mixture.
- Avoid getting dirt or water into the fuel tank.
- Do not use a mixture of gasoline containing methanol. This will cause serious damage to the engine.
- Use of gasoline with an ethanol content greater than 10% can damage the engine and fuel system and will void the manufacturer's warranty.

### **3.4 CHECK THE COLD WATER SUPPLY**

- Check local regulations of your municipal water company to check if a backflow prevention device is required when hooking up to drinking water. This ensures no feedback of chemicals will return to the water supply. Use a water filter to avoid potential damage from dirt in the water supply.
- Garden hose must be at least 1/2" interior diameter.
- Flow rate of water must not fall below 5.0 GPM. Flow rate can be determined by running hose into an empty 5 gallon pail for 1 minute.
- The water supply temperature must not exceed 40°C/104°F.
- Never use the pressure washer to draw in water contaminated with solvents eg. paint thinners, gasoline, oil etc.
- Always prevent debris from being drawn into the unit by using a clean water source and additional water filter.
- DO NOT operate pressure washer without the water supply turned on.

### 3.5 ASSEMBLE THE SPRAY WAND AND HOSES

#### Spray Wand Assembly



1. Rotate the coupler on the trigger handle assembly clockwise to tighten the spray wand. Tighten by hand.

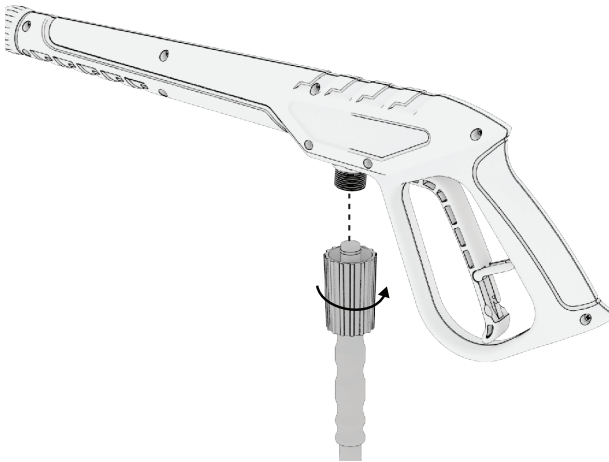

2. Rotate the coupler on the high pressure hose clockwise until secured onto the spray gun. Tighten by hand.



## Hook Up the High Pressure Hose

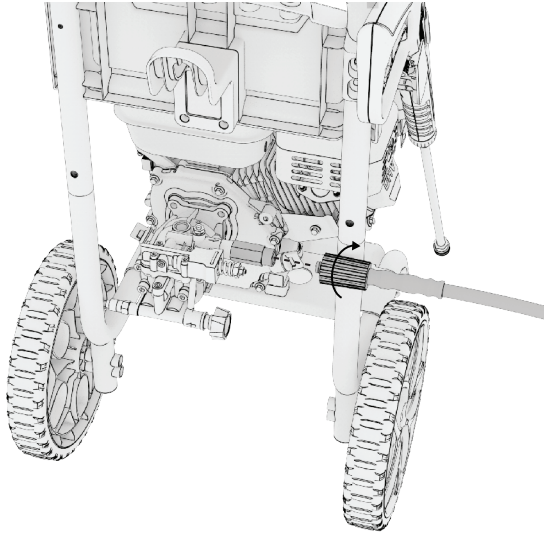

1. Attach the end of the high pressure hose to the high pressure outlet on the pump by tightening clockwise.

### **Note**

- Double check the high pressure hoses are securely tightened on both ends. The pressure may cause bodily harm if the fittings separate.

## Hook Up the Water Supply Hose

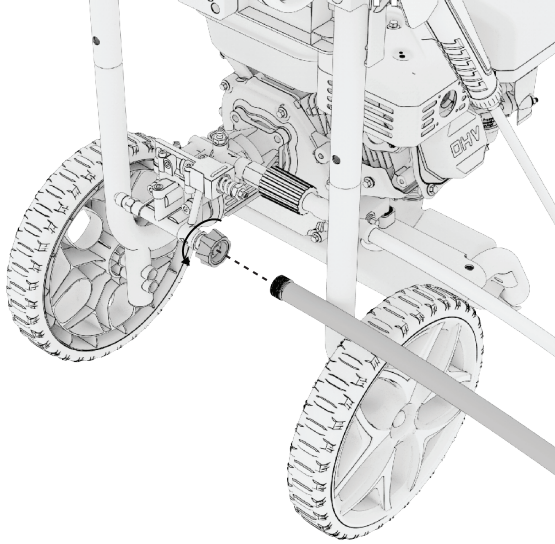



1. Run water through the garden hose to clear out any debris.
2. Pull out and inspect the water inlet filter to ensure it is in place and free of debris.
3. Connect the garden hose by threading it onto the pump. Connect the other side to the outdoor tap. Use the shortest hose possible to complete the job, do not use a hose longer than 50 feet (15.2m).
4. Hand tighten the fitting onto the hose.
5. Turn the water on and inspect for leaks.
6. Squeeze the trigger on the gun and allow any air to bleed out of the system before starting the engine.

### Note

- Do not operate the pressure washer with missing or damaged water inlet filter.
- Do not start the engine without the water supply connected and turned on. Water supply must deliver at least 5.0GPM at 30psi. Do not draw from standing water supply. Water temperature must not exceed 104°F (40°C).

## 4. STARTING YOUR PRESSURE WASHER

**⚠ DANGER! ⚠**

<b>⚠ DANGER</b>	
Using a generator indoors <b>CAN KILL YOU IN MINUTES</b> . Generator exhaust contains carbon monoxide. This is a poison you cannot see or smell.	
 	
<b>NEVER</b> use inside a home or garage, <b>EVEN IF</b> doors and windows are open.	Only use <b>OUTSIDE</b> and far away from windows, doors, and vents.
Avoid other generator hazards. <b>READ MANUAL BEFORE USE.</b>	

**Using a pressure washer indoors WILL KILL YOU IN MINUTES.**

**Pressure washer exhaust contains high levels of carbon monoxide (CO), a poisonous gas you cannot see or smell. If you can smell the pressure washer exhaust you are breathing CO. Even if you cannot smell the exhaust, you could be breathing CO.**

**NEVER** use a pressure washer inside a home, garage, crawlspace, or other partly enclosed area, deadly levels of carbon monoxide can build up in these areas. Using a fan or opening windows and doors will **NOT** supply enough fresh air.

**ONLY** use a pressure washer outdoors and far away from open windows, doors, and vents. These openings can pull in pressure washer exhaust. Even when you use a pressure washer correctly, **CO** may leak into the home. **ALWAYS** use a **CO** alarm in your home.

**If you start to feel sick, dizzy, or weak after the pressure washer has been running, move to fresh air RIGHT AWAY and seek medical attention. You could have carbon monoxide poisoning. Never run the pressure washer in an enclosed or even partially enclosed area where people may be present.**

**⚠ WARNING!**

**Do not run the pump without connecting to the water supply and turning the water on. Failure to do so could damage the pressure washer. Failure to follow these instructions will void product warranty.**

**Water that passes through this unit is not drinking water safe.**

**⚠ DANGER! ⚠**

**NEVER direct the water flow at people. The high pressure jet can be dangerous if misused and must not be directed at people, animals, electrical devices or the unit itself. DO NOT TREAT FLUID INJECTION AS A SIMPLE CUT! Seek medical help immediately.**

**Note**

- Do not push the choke knob to the START/CLOSED position when the engine is hot or ambient air temperature is high.
- If recoil starting, return the starter grip slowly by hand, do not let it snap back.

### 4.1 RECOIL ENGINE START

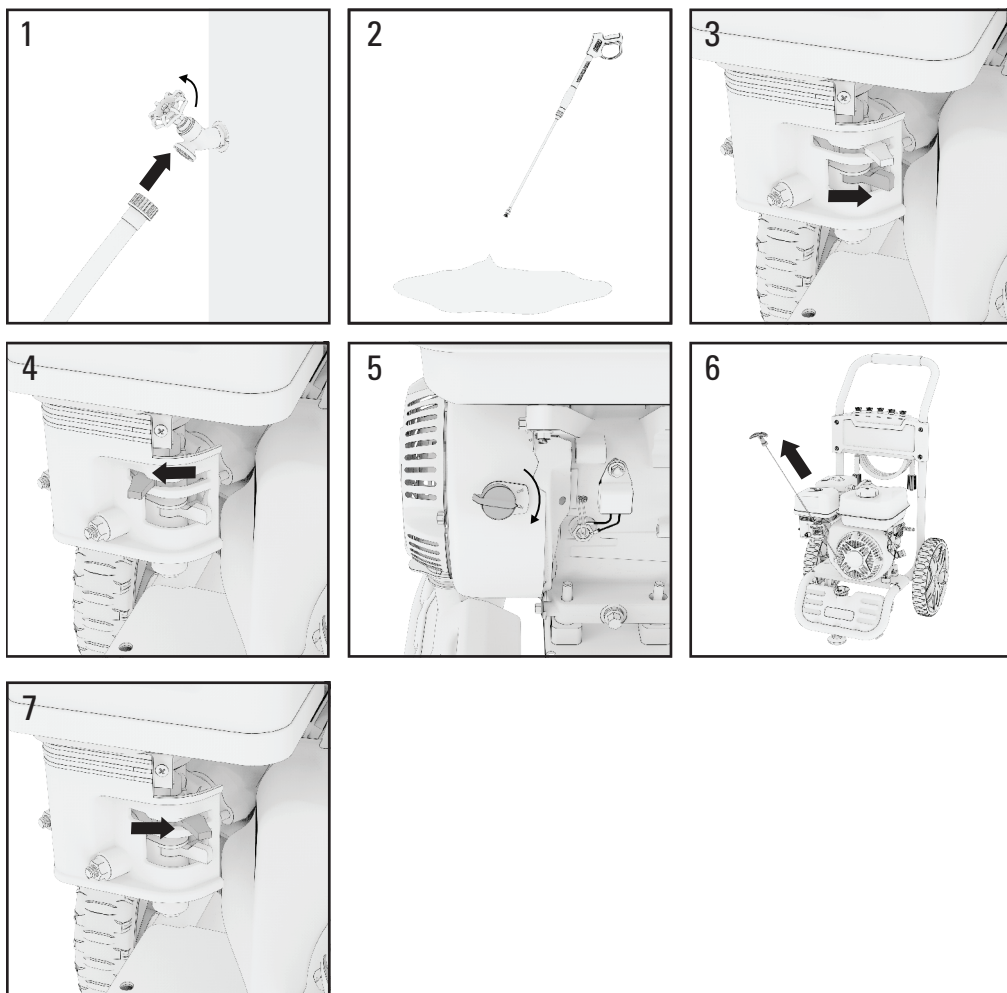

1. Turn on water supply to full.
2. Purge the air from the pump by releasing the safety and squeezing the trigger of the spray gun until there is a steady stream of water and no air coming through.
3. Turn the fuel lever to the OPEN position.
4. Turn the choke lever to the START position.
5. Turn the engine power switch to the ON position.
6. Pull the recoil starter slowly until resistance is felt, then pull rapidly. Squeeze the gun trigger and release the pressure after every failed recoil attempt to start the pressure washer.
7. Let engine run for several seconds and then slowly turn the choke lever towards the RUN position as the engine warms up until the choke is fully in the RUN position.

**Note**

- DO NOT allow the unit to run for more than 2 minutes without the gun trigger being pulled. This could cause overheating and damage to the pump. When the temperature inside the pump gets too high the thermal relief valve will temporarily open and release a spray of water from the pump to lower the internal temperature.

## 4.2 STOPPING THE PRESSURE WASHER

### Normal Operation

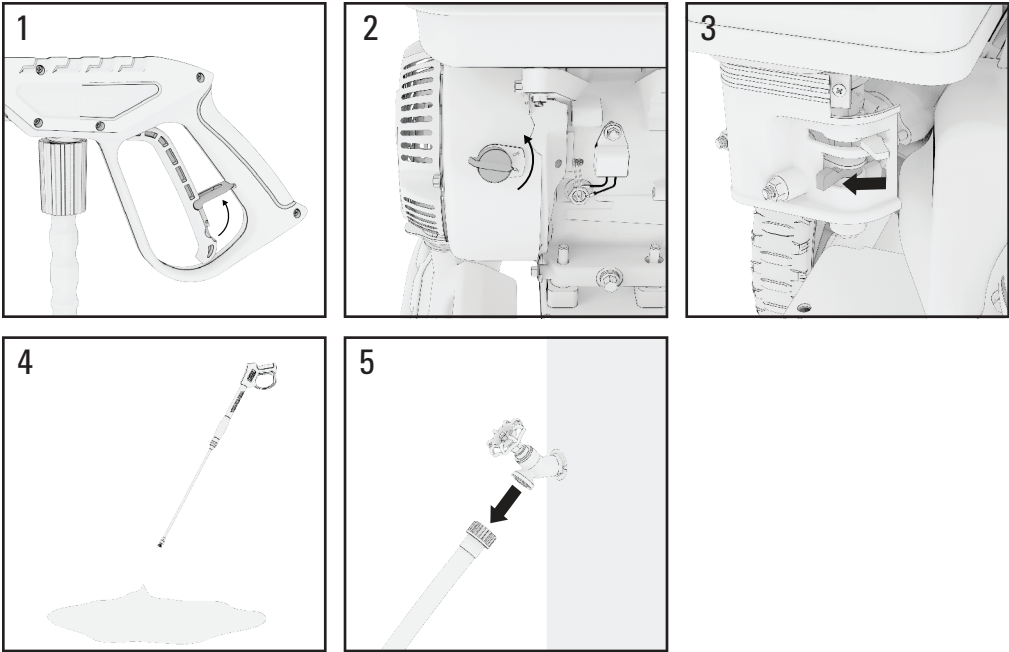

1. Engage the safety on the spray wand trigger.
2. Turn the engine power switch to the OFF position.
3. Turn the fuel lever to the CLOSED position.
4. Turn off the water supply. Unlock the safety of the spray trigger and depressurize the system by squeezing the trigger until the water stops flowing. Then flip the safety lock back to the locked position.
5. Unplug all hoses.

### Emergency Stop (All Models)

1. To stop the engine in an emergency, turn the power switch OFF immediately.

#### **Note**

- Make sure the fuel valve and engine switch are in the OFF position when stopping, transporting, and storing the pressure washer.

## 5. PRESSURE WASHER OPERATION

### **⚠ DANGER! ⚠**

**NEVER direct the water flow at people. The high pressure jet can be dangerous if misused and must not be directed at people, animals, electrical devices or the unit itself. DO NOT TREAT FLUID INJECTION AS A SIMPLE CUT! Seek medical help immediately.**

### **⚠ WARNING!**

**Do not run the pump without connecting to the water supply and turning the water on. Failure to do so could damage the pressure washer. Failure to follow these instructions will void product warranty. This unit is not drinking water safe.**

### 5.1. USING THE SPRAY WAND

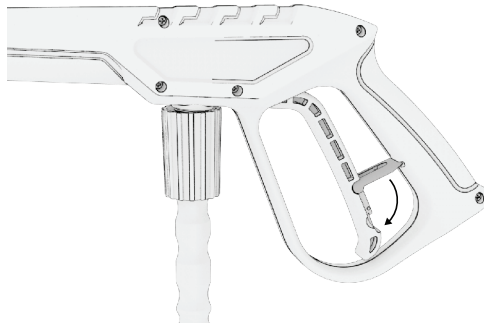

1. Flip the safety down until it clicks to remove the safety.
2. Pull back on the trigger to begin operating pressure washer.
3. To stop water flow, release the trigger.

#### **Note**

- DO NOT allow the unit to run for more than 2 minutes without the gun trigger being pulled. This could cause overheating and damage to the pump. When the temperature inside the pump gets too high the thermal relief valve will temporarily open and release a spray of water from the pump to lower the internal temperature.

## 5.2. USING THE SPRAY NOZZLES

### **⚠ WARNING!**



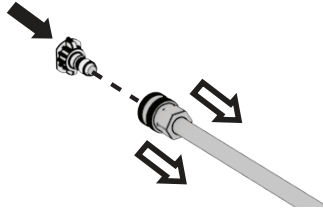

**The trigger safety lock MUST be engaged when replacing nozzles while the engine is running.**

**High pressure in nozzle area. Risk of injury caused by improperly locked nozzle.**



1. To connect or disconnect a nozzle pull back on the quick connect collar. Insert or remove the nozzle then release the collar. Tug on the nozzle to ensure it is secured. The nozzles are color coded and stored on the panel.

### Nozzle Selection Guide

	 0°	 15°	 25°	 40°	 65°
Paint Stripping	✓	✓			
Concrete	✓	✓	✓		
Siding			✓	✓	✓
Deck			✓	✓	✓
Gutters			✓	✓	✓
Vehicles				✓	✓
Windows				✓	✓
Furniture				✓	✓
Detergent					✓



**Note**

- 0° RED nozzle – maximum pressure: outputs a very concentrated stream of water. This nozzle should be used for removing tough stains and debris from concrete and metal. **THIS NOZZLE WILL DAMAGE SOFT SURFACES. DO NOT** use on wood, siding, decks, painted surfaces, windows, or vehicles.
- 15° YELLOW nozzle: used to prepare surfaces for painting. Can be used for surface preparation such as removing dirt, mildew, or paint from hard surfaces. **DO NOT** use on painted surfaces, windows, or vehicles.
- 25° GREEN nozzle: gentle lifting and cleaning for most surfaces. This nozzle is safe to use on most surfaces, attempt cleaning with this nozzle before using the YELLOW or RED nozzles. **DO NOT** use on windows or vehicles.
- 40° WHITE nozzle: safe to use on all surfaces, including windows, blinds, and vehicles. This nozzle can be used for rinsing after using the soaping nozzle.
- 65° BLACK soaping nozzle: low pressure detergent nozzle. Use when applying detergents for your cleaning projects. Detergents will only be drawn from the detergent source when this nozzle is equipped.

**Rinsing with the Pressure Washer**

1. Test a small area first to avoid surface damage.
2. Rinse from top to bottom using long, overlapping strokes.

## 5.3 WORKING WITH DETERGENTS

### Note

- Detergents are automatically applied with the low pressure black nozzle.
- Detergent will not be applied with the high pressure nozzles.
- DO NOT use bleach.
- Dilution ratio of this pressure washer is 1:30

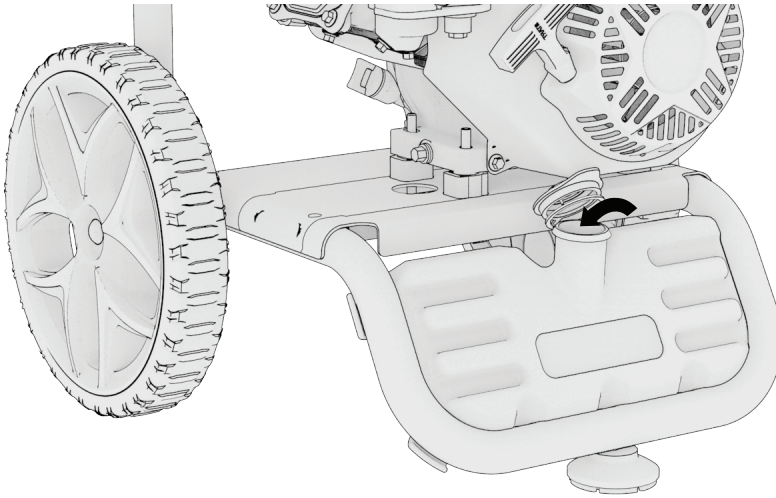

1. Attach the black soap nozzle to the spray wand.
2. Prepare detergent as required by job, follow directions as supplied from manufacturer.
3. Remove cap from detergent compartment and fill. Replace when filled.
4. Spray detergent mixture on surface with long, even and overlapping strokes. Allow detergent to set for about 3 minutes before rinsing (do not allow detergent to dry on surface or it may cause streaking or cause damage to the surface).
5. Rinse surface with clean water by switching to a high pressure nozzle (0, 15, 25, or 40 degree nozzles)
6. To clean equipment after use, fill the detergent tank with clean water. Spray clean water through the black low pressure soap nozzle until tank is empty then shut off the engine.

**Note**

- Only use mild, environmentally friendly detergents intended for use with pressure washers. Never use aggressive chemicals (like bleach), abrasive detergents, or similar to avoid damage to your health, the product, and the environment.
- Remaining chemicals that dry in the system may cause damage. Damage caused by chemical residue will not be covered under warranty.

## 5.4 DETERGENT DILUTION

**Note**

- Dilution ratio of this pressure washer is 1:30

The washer will draw 1 part detergent solution for every 30 parts water used. Use this to calculate the proper dilution ratio when combining your detergent and water in your detergent container. For example, if your detergent requires a dilution of 1:120, you should only dilute it with 4 parts water to 1 part detergent in the detergent container, before allowing the pressure washer to further dilute it to 1:120.

## 5.5 CARBURETOR MODIFICATION FOR HIGH ALTITUDE OPERATION

- At high altitudes, the standard carburetor air-fuel mixture will be too rich. Fuel consumption will increase and performance will decrease. A very rich mixture will also foul the spark plug and cause hard starting.
- If using the pressure washer at high altitudes, change the main carburetor jet or adjust the idling-screw of the carburetor. If always operating the pressure washer at altitudes above 1,000 meters, contact an authorized service center to have the carburetor modified.
- Conversely, if the carburetor has been modified for high altitude operation, the air-fuel mixture will be too lean for low altitude use. Operation at low altitude may cause the engine to overheat and result in serious engine damage. In this case the carburetor needs to be returned to its original specifications.

## 6. MAINTENANCE

Proper maintenance keeps your pressure washer in the best operating condition by ensuring safe, economical and trouble-free operation. Only use genuine parts and recommended fluids to replace the worn components. Improper maintenance may cause the pressure washer to malfunction and can lead to serious injury. Contact customer support if you have any maintenance questions.

### General Inspection Tips

- Look for fuel leaks around the fuel tank, fuel hose, and fuel valve. Close the fuel valve and repair leaks immediately.
- Look and listen for exhaust leaks while the engine is running. Have all the leaks repaired before continuing operation.
- Check for dirt and debris and clean as necessary .
- Check the engine oil level and add oil as necessary.

## 6.1 MAINTENANCE SCHEDULE

Regular maintenance will improve performance and extend the service life of the pressure washer. Maintain the pressure washer according to the maintenance schedule below.

### Note

- Service more frequently when used in dusty areas.
- These items should be serviced by an authorized service center, unless you have the proper tools and are mechanically proficient. Refer to user guide for service procedures.

<b>Before Each Use</b>
Check engine oil level Inspect air filter
<b>First 20 Hours or First Month</b>
Change engine oil
<b>Every 50 Hours or 6 Months</b>
Check and clean air filter <sup>1</sup> Check and clean sediment cup
<b>Every 100 Hours or 12 Months</b>
Change engine oil <sup>2</sup> Inspect/clean spark plug Clean fuel line
<b>Every 300 Hours</b>
Replace spark plug Replace air filter Clean combustion chamber <sup>3</sup> Inspect/adjust valve clearance <sup>3</sup> Clean fuel tank and strainer

<sup>1</sup> Every 100 hours or every year, whichever comes first <sup>1</sup> Replace air filter if it cannot be adequately cleaned.

<sup>2</sup> Change oil after every 100 hours or yearly, whichever comes first. Service more frequently when operating under heavy load or in high temperatures.

<sup>3</sup> Recommend service to be performed by authorized service dealer.

## 6.2 CHANGING THE ENGINE OIL

### **⚠ WARNING!**

**Used motor oil can cause skin irritations if left in long-term contact with skin. Thoroughly wash off used oil as soon as possible with soap and water.**

**Do not dispose of used oil in drains or on soil. Local service shops provide environmentally-friendly disposal methods.**

Drain the oil rapidly and completely on a level surface while the engine is still warm.

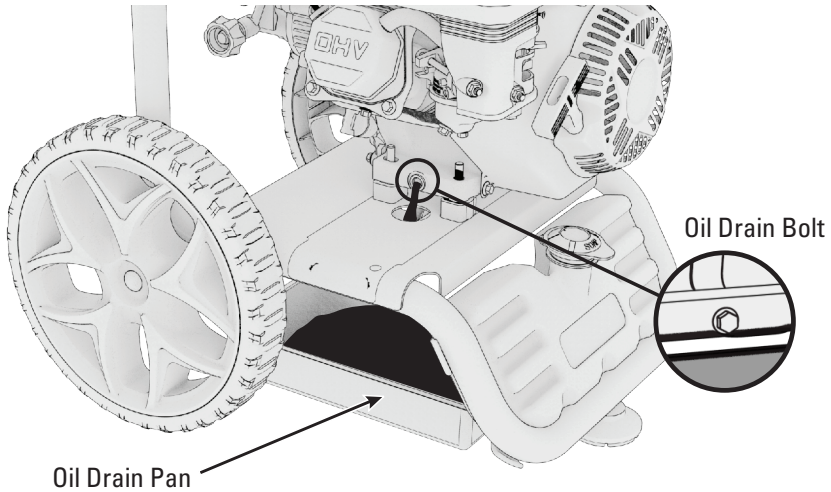

1. Stop the engine and remove oil dipstick.
2. Place a pan under the engine to catch the oil.
3. Remove the oil drain bolt and allow the oil to completely drain into the pan by tilting the pressure washer to the side to empty the oil from the crankcase.
4. Return the pressure washer to a level position and reinstall drain bolt. Fill the engine with fresh oil (SAE 10W-30 4 Cycle Engine Oil) up to the maximum mark on the dipstick *without* threading it back in. Do not overfill oil reservoir. Use a funnel to prevent spillage.
5. Reinstall the oil dipstick and tightly fasten.

### **Note**

- Max. oil capacity (600mL)
- SAE 10W-30 oil is recommended for general use.
- DO NOT OVERFILL.

Effective Viscosity Range of Engine Oils

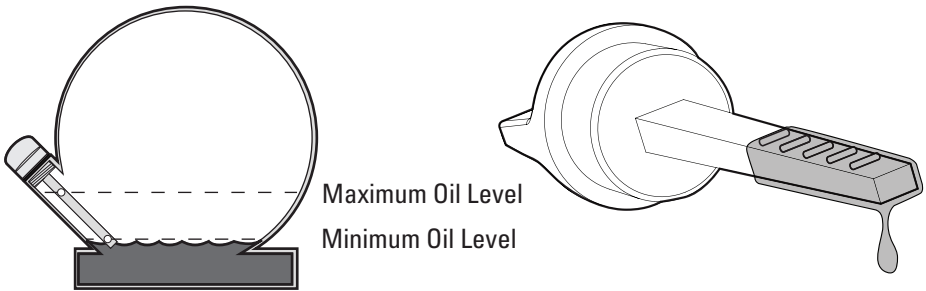
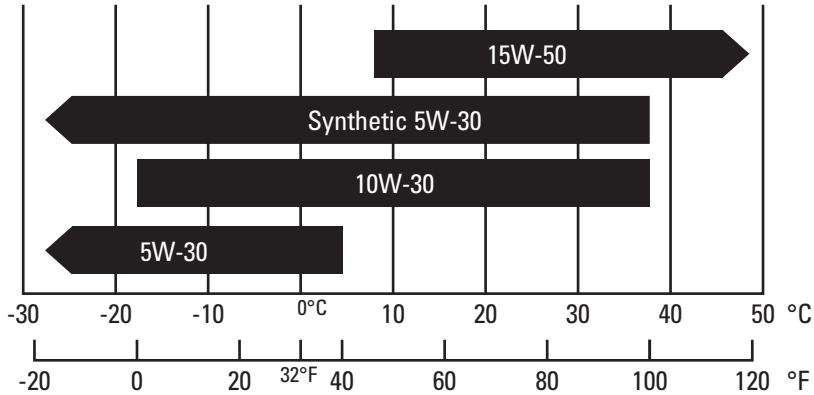

**Note**

- Do not tilt the pressure washer when adding engine oil. This could result in overfilling and damage to the engine.
- Use high quality engine oil with strong detergents. Using non-detergent or 2-stroke oil could shorten the engine's working life.
- Handle and store engine oil with care, avoid getting dirt or dust into the oil.
- Do not mix different engine oils.
- To avoid the inconvenience of unexpected engine shutoff, check the engine oil level as often as possible.
- Use 4-stroke engine oil, certified to meet or exceed API standard SG, SF, SAE ratings.

### 6.3 PUMP OIL

This unit has a sealed pump which ships filled with oil from the factory. There is no need to add or change the pump oil.

## 6.4 CLEANING THE AIR-FILTER

### **⚠ WARNING!**

**Using gasoline or other flammable solvents can cause a fire or explosion. Do not operate this product without an air filter.**

A dirty air filter will restrict air flow into the carburetor. Clean and maintain the air filter regularly, especially in dusty areas.

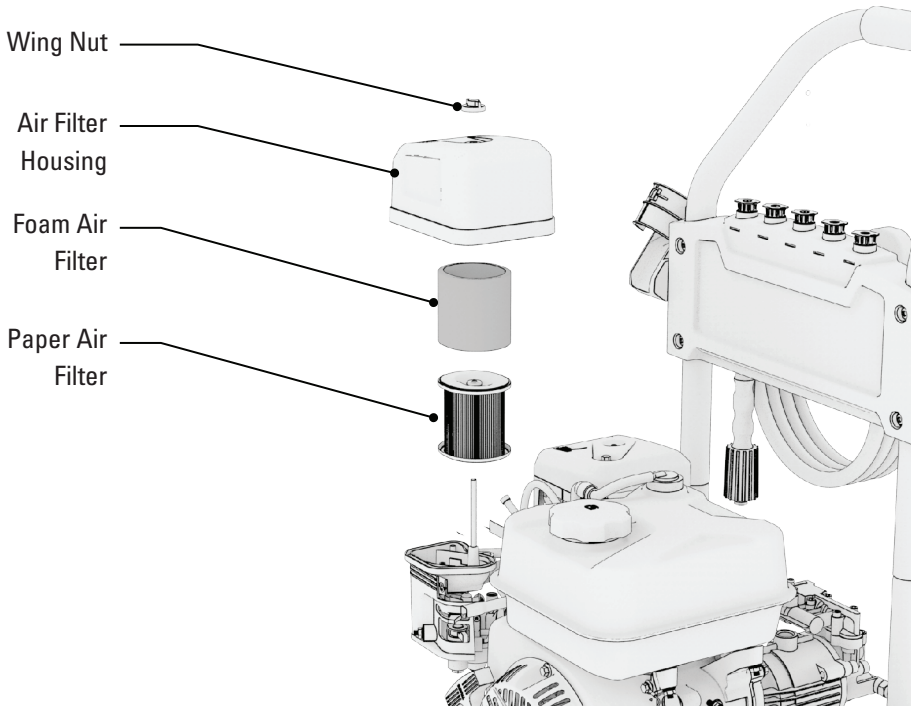

1. Loosen the nut and remove the air filter cover. Remove the air filter housing and elements and inspect for cleanliness.
2. Gently shake the *paper* filter or blow with air to remove the dust and debris.
3. Clean the *foam* air filter with soap and water or solvent and let dry.
4. Soak the *foam* filter in clean engine oil.
5. Gently squeeze and then pat out all excess oil and reinstall. If excess oil remains in the foam filter it can seep through to the paper filter and damage it.
6. Replace either filter if it is damaged.

### **Note**

- Never run the pressure washer without an air filter, doing so will quickly degrade the engine.



## 6.5 NOZZLE CLEANING

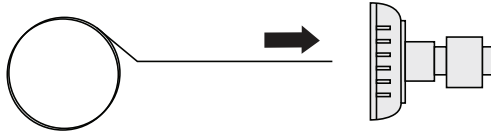

1. Detach the quick connect nozzle from the wand. Use the included nozzle cleaning tool or a paper clip to loosen up any stuck particles in the nozzle. Flush with water.

## 6.6 CLEANING WATER INLET FILTER

Check the water inlet filter periodically and clean if necessary.

## 6.7 SPARK PLUG SERVICE

### Note

- Do not rinse spark plug in water. Follow guidelines and be careful not to overtighten the spark plug.

Recommended spark plug: **F7TC**

Check the spark plug gap and clean the carbon deposits at the bottom of the spark plug.

**Tighten 1/2 turn when installing a new spark plug.**

**Tighten 1/8 TO 1/4 turn when re-installing an old spark plug.**

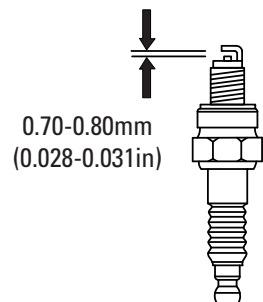
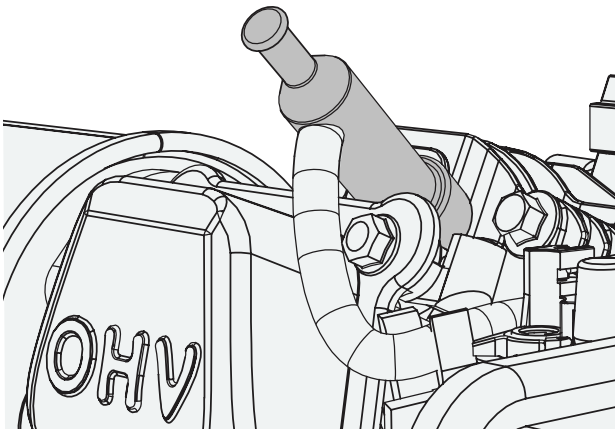

1. Remove the spark plug cap.
2. Remove the spark plug with the spark plug wrench.
3. Visually inspect the spark plug. Replace with a new plug if the insulation is cracked or chipped. Clean with a wire brush if the spark plug is reused.
4. Measure the spark plug gap with a feeler gauge. The normal value is: 0.7-0.8mm (0.028- 0.031in). Adjust the gap by carefully bending the electrode.
5. Carefully reinstall the spark plug by hand, to avoid cross-threading. A new spark plug should be tightened 1/2 turn with a spanner. A used spark plug should be tightened 1/8 to 1/4 turn with spanner.
6. Reinstall the spark plug cap.

**Note**

- The spark plug must be securely tightened or it could cause the spark plug to heat up, enough to damage the engine.
- Never use a spark plug with an improper heat range.

## 6.8 SPARK ARRESTER MAINTENANCE

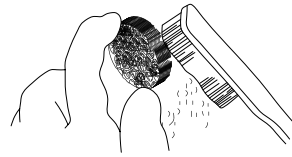
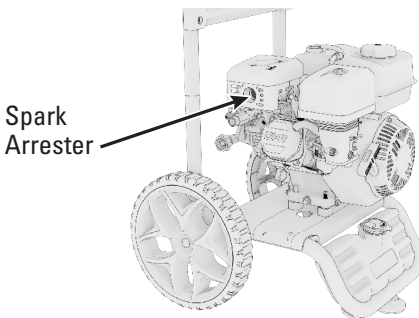

1. After the engine has cooled down remove the spark arrester from the muffler.
2. Use a brush to remove carbon deposits from the spark arrester. If the spark arrester is worn down, replace it.
3. Reinstall the spark arrester.

## 6.9 FUEL FILTER MAINTENANCE

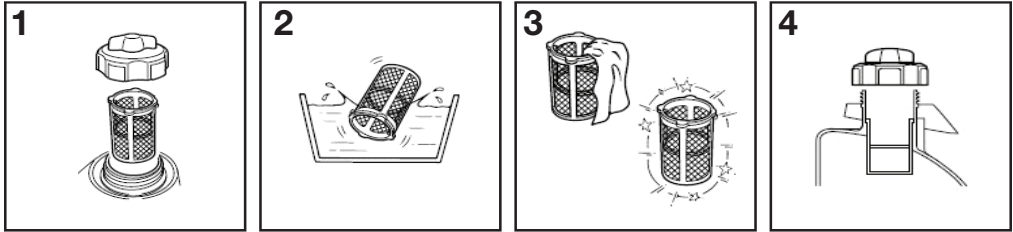

1. Remove the fuel cap and filter.
2. Clean the filter with solvent.
3. Wipe the filter.
4. Reinsert the filter.

## 6.10 EMISSION CONTROL SYSTEM

### Emission Source

Exhaust gas contains carbon monoxide, nitrogen oxides (NO<sub>x</sub>) and hydrocarbons. It is very important to control the emissions of NO<sub>x</sub> and hydrocarbons as they are a major contributor to air pollution. Carbon monoxide is a poisonous gas. The emission of fuel vapors is a source of pollution as well. The pressure washer engine utilizes a precise air-fuel ratio and emission control system to reduce the emissions of carbon monoxide, NO<sub>x</sub>, hydrocarbons and evaporative fuel emissions.

### Regulation

Your engine has been designed to meet current Environmental Protection Agency (EPA) clean air standards. The regulations dictate that the manufacturer provides operation and maintenance standards regarding the emission control systems. Tune up specifications are provided in the Specifications section and a description of the emission control system may be found in the appendix to this manual. Adherence to the following instruction will ensure your engine meets the emission control standards.

### Modification

Modification of the emission control system may lead to increased emissions. Modification is defined as the following:

- Disassembling or modifying the function or parts of the intake, fuel or exhaust system.
- Modifying or destroying the speed governing function of the pressure washer.

## **Engine faults that may affect emission**

Any of the following faults must be repaired immediately. Consult with your authorized service centre for diagnosis and repair:

- Hard starting or shut down after starting.
- Unstable idle speed.
- Shut down or backfire after applying an electrical load.
- Backfire or after fire.
- Black smoke and/or excessive fuel consumption.

## **Replacement parts and accessories**

The parts making up the emission control system in your product's engine have been specifically approved and certified by the regulatory agencies. You can trust that the replacement parts supplied by customer service have been manufactured to the same production standard as the original parts. The use of replacement parts or accessories which are not designed for your engine – may negatively affect the engine emission performance. Therefore only use replacements parts and accessories from a qualified service centre to guarantee that the replacement products will not adversely affect emission performance.

Replacement parts other than those from an authorized service centre will void the warranty.

# 7. TRANSPORTATION & STORAGE

## 7.1 TRANSPORTING THE PRESSURE WASHER

- Do not overfill the fuel tank (No residual fuel on the neck of tank).
- Avoid exposing the pressure washer to prolonged direct sunlight while

Storage Duration	Preparation Required
Less than 1 Month	<ul style="list-style-type: none"> <li>■ No storage preparation required, simply store as is.</li> </ul>
1 Month to 1 Year	<ul style="list-style-type: none"> <li>■ Drain the old gas and completely fill the tank with fresh gas before storage. Add fuel stabilizer according to the manufacturer's directions. Run the engine outdoors for 5-10 minutes to ensure the stabilized gas has replaced the untreated gas in the carburetor. Adding a quality fuel stabilizer can keep gas fresh for up to a year.</li> </ul>
1 Year or More	<ul style="list-style-type: none"> <li>■ Drain off the gasoline from the fuel tank, and store in a suitable container. This will help prevent deposits from forming in the fuel system.</li> <li>■ Turn the fuel switch to OPEN and loosen the carburetor drain bolt. Take off the spark plug cap and revolve the engine 3 or 4 times, by pulling the recoil handle, to fully discharge the gasoline from the fuel lines.</li> <li>■ Turn the fuel switch to CLOSED and tighten the drain bolt of the carburetor.</li> <li>■ Change oil while engine is still warm from operation.</li> <li>■ Remove the spark plug, and pour a tablespoon of clean engine oil (10-20ml) into the cylinder. Revolve the engine several times by pulling on the recoil start to distribute the oil. Reinstall the spark plug. Pull the starter grip slowly until you feel resistance. At this point, the piston is coming up on its compression stroke and both the intake and exhaust valves are closed. This position helps to protect the engine from internal corrosion.</li> </ul>

in an enclosed vehicle. The high temperature inside the vehicle could cause fuel to vaporize resulting in a possible explosion.

- Drain the pressure washer of fuel and oil before being transported on rough roads.

## 7.2 DRAINING THE FUEL TANK

1. Turn OFF the engine. Remove the fuel cap and the debris screen underneath the fuel cap.
2. Empty the fuel tank using a siphon and an approved gasoline container.

## 7.3 DRAINING THE CARBURETOR

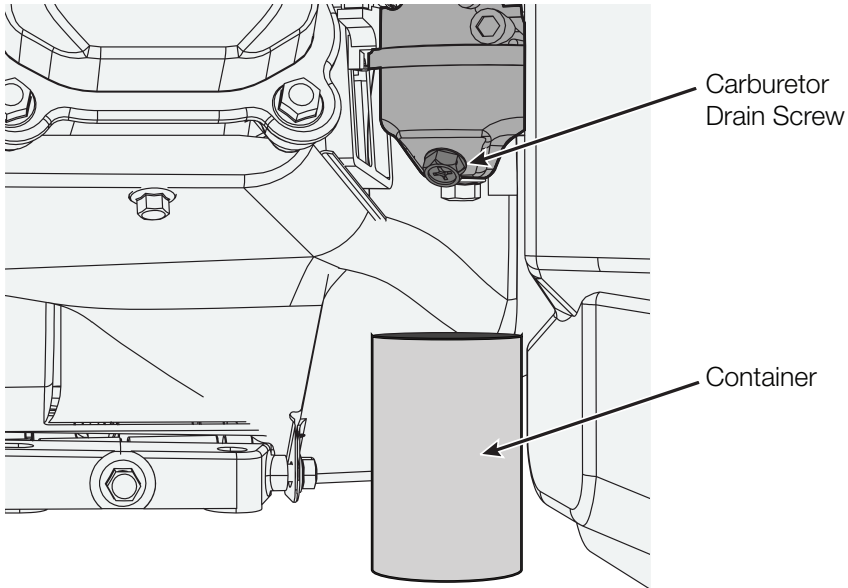

1. Turn OFF the engine and allow it to cool. Turn the fuel valve to OPEN.
2. Position a container under the carburetor drain screw. Loosen the drain screw.
3. Allow fuel to completely drain and re-tighten the drain screw.
4. Turn the fuel valve to CLOSED.

## 7.4 LONG TERM STORAGE - ENGINE

Before storing the pressure washer set for an extended period:

- Ensure that the storage area is free of excess humidity and dust.
- Drain the fuel tank and the carburetor.

## 7.5 LONG TERM STORAGE - PUMP

When storing your unit for more than 30 days pressure washer pump guard (pump saver or pump winterizer) is recommended to keep seals lubricated, protect from rust, and prevent the pump from freezing damage.

### Note

- DO NOT let water in the pump freeze. It will cause irreversible damage to the pump.
  - Pump guard application may require two people.
1. Turn off pressure washer and disconnect all hoses.
  2. Connect the pump saver to the water supply inlet.
  3. Depress the button on top of the pump saver container.
  4. With the ignition off, pull the starter rope and squeeze the bottle. Repeat until pump guard fluid exits the high pressure hose outlet. This may require two people.
  5. Remove the hose from the water supply inlet.

## 7.6 LONG TERM STORAGE - HOSES

1. Drain all water from the high pressure hose and wrap it onto the holder.
2. Drain all water from the spray gun by holding it vertically with the nozzle down and squeezing the trigger until the water stops flowing.
3. Ensure the detergent siphon hose is drained and wrap it up securely.

## 8. TROUBLESHOOTING

Problem	Possible Cause	Solution
Engine will not start	<ul style="list-style-type: none"> <li>■ No gasoline</li> <li>■ Engine oil low</li> <li>■ Choke is in the incorrect position</li> <li>■ Water pressure built up after two recoil pulls</li> <li>■ Spark plug cap disconnected</li> <li>■ Fouled spark plug</li> </ul>	<ul style="list-style-type: none"> <li>■ Add fuel</li> <li>■ Add engine oil</li> <li>■ Move choke to the Start position</li> <li>■ Squeeze the trigger after each failed recoil start to release the pressure</li> <li>■ Connect spark plug cap</li> <li>■ Replace spark plug</li> </ul>
Engine hard to start	<ul style="list-style-type: none"> <li>■ Stale fuel or water in fuel</li> </ul>	<ul style="list-style-type: none"> <li>■ Drain fuel and refill with fresh gas</li> </ul>
Engine lacks power and vibrates excessively	<ul style="list-style-type: none"> <li>■ Choke in the Start position</li> <li>■ Dirty air filter</li> </ul>	<ul style="list-style-type: none"> <li>■ Move choke to the Run position</li> <li>■ Clean air filter</li> </ul>
Not reaching high pressure	<ul style="list-style-type: none"> <li>■ Low pressure black detergent nozzle is attached</li> <li>■ Low water supply</li> <li>■ Water supply is restricted</li> <li>■ Water inlet filter is clogged</li> <li>■ Nozzle obstructed</li> <li>■ High pressure hose is too long</li> </ul>	<ul style="list-style-type: none"> <li>■ Remove and attach a high pressure nozzle</li> <li>■ Water supply must be at least 5.0GPM @ 30 PSi from a 1/2" diameter hose minimum</li> <li>■ Check hose for leaks, kinks, or blockages. Ensure the tap is all the way open.</li> <li>■ Remove filter and rinse in warm water. Reinstall.</li> <li>■ See nozzle cleaning instructions</li> <li>■ Max high pressure hose of 100 feet (30m)</li> </ul>



<p>Detergent does not mix with water</p>	<ul style="list-style-type: none"> <li>■ Spray wand not in low pressure</li> <li>■ Chemical screen not in cleaning solution</li> <li>■ Chemical too thick</li> </ul>	<ul style="list-style-type: none"> <li>■ Remove and attach the black low pressure nozzle. Detergents will only be drawn at low pressure</li> <li>■ Ensure end of detergent siphone hose is fully submerged into cleaning solution</li> <li>■ Dilute chemical. It should be the same consistency as water</li> </ul>
<p>Inconsistent or low pressure during use</p>	<ul style="list-style-type: none"> <li>■ Water supply is restricted</li> <li>■ Water supply not turned on full power</li> <li>■ Nozzle is clogged</li> <li>■ Spray gun leaks</li> <li>■ Air in line</li> <li>■ Inlet hose screen is clogged</li> <li>■ Water supply temperature is over 104°F</li> <li>■ Pump is faulty</li> </ul>	<ul style="list-style-type: none"> <li>■ Inspect garden hose for kinks, leaks, or blockages. Use min. of 1/2" garden hose</li> <li>■ Open water supply tap all the way</li> <li>■ Clean nozzle</li> <li>■ Check all connections. Use sealant tape if necessary</li> <li>■ Squeeze trigger handle to remove air in line</li> <li>■ Clean inlet filter in warm water</li> <li>■ Use cool water supply</li> <li>■ Contact technical support</li> </ul>
<p>Water leaking at spray wand connection or pump</p>	<ul style="list-style-type: none"> <li>■ Loose connections</li> <li>■ Worn spray wand o-ring</li> <li>■ Piston packings worn</li> <li>■ Worn pump o-ring</li> <li>■ Pump head or tubes damaged from freezing</li> </ul>	<ul style="list-style-type: none"> <li>■ Tighten</li> <li>■ Replace</li> <li>■ Contact technical support</li> <li>■ Contact technical support</li> <li>■ Contact technical support</li> </ul>

## 9. TECHNICAL SPECIFICATIONS

		<b>RW3200</b>
<b>Pressure washer</b>	PSI Max.	3200 PSI
	GPM Max.	2.8 gpm
	High Pressure Hose	30 ft. (9.1m)
	Pressure of Inlet Water	30-100 PSI
	Inlet Water Temperature	Cold tap (40°C/104°F Max.)
	Soap Tank Capacity	1.6L / 0.42Gal
	Soap Consumption Rate	1:30
<b>ENGINE</b>	Type	6.5 HP, Single Cylinder, forced air cooling, 4-stroke, OHV
	Displacement (cm <sup>3</sup> )	212cc
	Rpm	3400-3600
	Fuel tank capacity (Gal)	3.6L / 0.92 Gal
	Oil capacity	600mL / 20 oz. (10W30)
	Fuel Type	Unleaded gasoline 87+ Octane
<b>UNIT</b>	L x W x H	24.2 x 19.3 x 38.2"
	Gross Weight	59.5 lbs

## 10. LIMITED WARRANTY

Online: [radley.midlandpowerinc.com](http://radley.midlandpowerinc.com)  
Email: [support@midlandpowerinc.com](mailto:support@midlandpowerinc.com)  
Toll Free: 1-877-528-3772

### **Radley products are distributed and supported by:**

Midland Power Inc.  
376 Magnetic Drive, Toronto, ON M3J 2C4, Canada

This product is warranted to be free of defects in material and workmanship for three (3) years from date of purchase. This warranty guarantees that any defective parts will be repaired or replaced at no cost, including diagnosis and replacement parts.

### **Limited Warranty Periods**

Recreational and Residential use: Three (3) Years Limited

- 1st Year: Parts and Labor
- 2nd to 3rd Year: Parts only

Commercial use: Six months limited, parts and labor

This limited warranty begins at the initial time of retail purchase and covers manufacturer's defects caused by a defect in components or workmanship during the warranty period. The warranty coverage is continual from the initial date of purchase and does not restart at anytime under any circumstances. This limited warranty is valid for residential or recreational applications only and only when the pressure washer receives all necessary preventative maintenance as described in the User Guide.

The repair or replacement of a pressure washer will take place within a reasonable period of time during normal business hours. All repair and replacement parts shall be warranted for (90) days after the initial date of installation or purchase.

### **Limitation of Remedies and Disclaimers**

Midland Power Inc. disclaims any responsibility for loss of time, transportation, commercial loss, or any other incidental or consequential damage. Any implied warranties are limited to the duration of this written warranty.

**THE FOREGOING LIMITED WARRANTY IS EXCLUSIVE OF AND IN LIEU OF ALL OTHER WARRANTIES OF MERCHANTABILITY, FITNESS FOR A PARTICULAR PURPOSE AND OF ANY OTHER WARRANTY WHETHER EXPRESS OR IMPLIED.**

Consumable parts, such as oil or fuel filters, fuel cut off valve, brushes, fuel injection nozzle valve, lubricant, ignition plug, hoses, o-rings, seals, spray wand, feet, tires, or nozzles are not covered under this warranty. All expenses incurred in maintaining and replacing these parts for pressure washer shall fall on the purchaser. This warranty coverage does not include parts affected by accident and/or collision, corrosion or rust, normal wear, incorrect fuel type or fuel contamination, use in an application for which the product was not intended, unauthorized service, or any other misuse, neglect, incorporation or use of unsuitable attachments or parts. Under this Warranty, we do not have the obligation to bear any transportation fees of any product to/from an authorized service center. Unauthorized alteration, installation or any cause other than defects in material or workmanship of the product will not be covered under the warranty.

**Exclusions Not Covered by this Limited Warranty**

- Normal engine wear;
- Damage caused by lack of maintenance as described in the User Guides, or negligence by using improper or impure motor oil, coolant, or fuel;
- Damage caused by accidents, improper installation or storage;
- Damage caused by water ingestion, submersion, or external water damage;
- Damage caused by freezing
- Damage due to improper chemical use or improper cleaning
- Damage caused by operation with improper fuel, or at speeds, loads, conditions, or modifications contrary to published specifications;
- Items not supplied including, but not limited to, starting batteries, battery cables, external wiring, fuel lines, filters, etc; (refer to exclusions)
- Repairs made during the warranty period, without first obtaining a case number

## **Batteries**

Batteries supplied with any pressure washer product should be considered a bonus item and not covered by warranty. Batteries can be damaged by shock, shorting terminals, heat, acid spillage, neglect, and a number of other factors that cannot be controlled after they have left our facility. It is the customer's responsibility to take great care when handling a battery so no spillage of acid will occur and cause corrosion; damage caused by battery acid is not covered under this warranty.

## **Our Warranty Rights and Obligations**

### **California**

The California Air Resources Board and Midland Power Inc. are pleased to explain the emission control system warranty on your Midland Power Inc. engine. In California, new spark-ignited small off-road equipment engines must be designed, built, and equipped to meet the State's stringent anti-smog standards.

### **Other States, U.S. territories, and Canada**

In other areas of the United States and in Canada, your engine must be designed, built, and equipped to meet the U.S. EPA and Environment Canada emission standards for spark-ignited engines at or below 19 kilowatts.

### **All of the United States and Canada**

Midland Power Inc. must warrant the emission control system on your power equipment engine for the period of time listed below, provided there has been no abuse, neglect, or improper maintenance of your power equipment engine. Where a warrantable condition exists, Midland Power Inc. will repair your power equipment engine at no cost to you including diagnosis, parts, and labor.

Your emission control system may include such parts as the carburetor or fuel injection system, the ignition system, and catalytic converter. Also included may be hoses, connectors, and other emission-related assemblies.

## Emission Control System Warranty Parts:

This list applies to parts supplied by Midland Power Inc. and does not cover parts supplied by the equipment manufacturer. Please see the original equipment manufacturer's emissions warranty for non-Midland Power Inc. parts.

Consumable parts are covered up to a maximum of 30 days.

<b>SYSTEMS COVERED IN WARRANTY</b>	<b>PARTS DESCRIPTION</b>
Fuel Metering	Carburetor assembly (includes starting enrichment system), Engine temperature sensor, Engine control module, Fuel regulator, Intake manifold
Evaporative	Fuel Tank, Fuel Cap, Fuel Hoses, Vapor Hoses, Carbon Canister, Canister Mounting Brackets, Fuel Strainer, Fuel cock, Fuel Pump, Fuel Hose Joint, Canister Purge Hose Joint
Exhaust	Catalyst, Exhaust Manifold
Air Induction	Air filter housing, Air filter element
Ignition	Flywheel magneto, Ignition pulse pressure washer, Crankshaft position sensor, Power coil, Ignition coil assembly, Ignition control module, Spark plug cap, Spark plug
Crankcase Emission Control	Crankcase breather tube, Oil filler cap
Miscellaneous Parts	Tubing, fittings, seals, gaskets, and clamps associated with these listed systems

## **Warranty Claim Procedure**

Warranty service must be performed by one of our authorized service dealers. Do not return your product where purchased. If you feel your pressure washer is malfunctioning due to a defect or misuse, simply contact our customer support center for technical advice, a warranty claim or general information. Warranty service, operation assistance and product support is provided by Midland Power Inc., contact us at the numbers below.

## **Product Registration Instructions**

Product registration is required for product support and warranty coverage. You can register online at [radley.midlandpowerinc.com](http://radley.midlandpowerinc.com). Once your registration is complete, your receipt will be on file and any future warranty claims will be easily created. If you wish, you can confirm your registration by e-mail at [support@midlandpowerinc.com](mailto:support@midlandpowerinc.com)

Proof of purchase is required for warranty claims. Keep a copy of the original receipt, UPC code and serial number with this user guide.

## **Customer Service**

Online: [radley.midlandpowerinc.com](http://radley.midlandpowerinc.com)

Email: [support@midlandpowerinc.com](mailto:support@midlandpowerinc.com)

Phone: 1-877-528-3772

*Radley*