

BENCHMARK™

5049-726, 5049-727, 5049-728

HH0413, HH0414, HH0415



MANUAL



This product is supported by **Midland Power**. Contact us directly for assistance and warranty help. Do not return this product to store.

You must register online for your warranty to be valid. It only takes a minute, do it now while you still have your purchase receipt.

Register Your Product Online

[www.benchmark.midlandpowerinc.com/
register-warranty](http://www.benchmark.midlandpowerinc.com/register-warranty)



Support for your product is available online, including parts, service center locations, and live expert advice.

Visit us online at

www.benchmark.midlandpowerinc.com



Or call us anytime at **1-877-528-3772**.

Thanks for choosing Benchmark!

You're excited to get started, we'll keep this brief.

READ THIS ENTIRE GUIDE BEFORE USING THIS PRODUCT AND SAVE FOR LATER USE.

This user guide contains important instructions including safety, setup, operation, and maintenance that must be followed. All information in this guide is based on information available at the time of print. This guide or revised editions can be found on our website for download. No part of this publication may be reproduced without written permission.

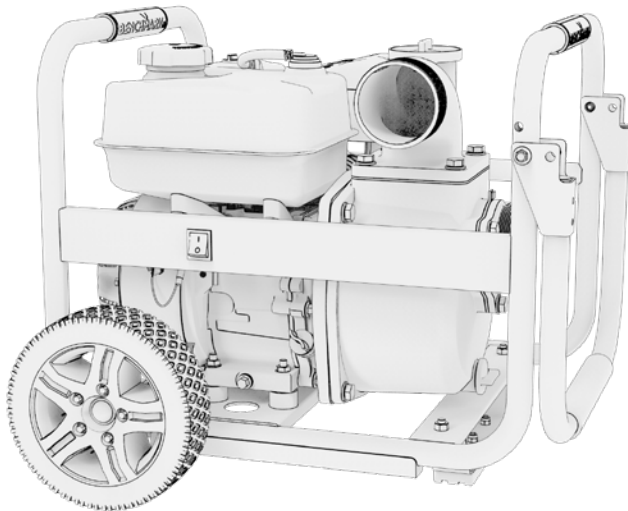

THIS PRODUCT MEETS ALL CERTIFICATION REQUIREMENTS FROM:



The engine exhaust from this product contains chemicals known to cause cancer, birth defects or other reproductive harm.



©2023 Benchmark. All Rights Reserved.

HH0413 HH0414 HH0415_Manual_EN_2023-12-14

TABLE OF CONTENTS

1. Safety	1
1.1 Safety While Operating Your Engine	1
1.2 Safety while Operating Your Water Pump	2
1.3 Maintenance Safety	3
1.4 Other Safety Tips	4
2. Learn About Your Water Pump	5
2.1 Component Identification	5
2.2 Control Functions	7
2.3 Make Sure You Have Everything	9
3. Pre-Operation Check	10
3.1 Check the Oil Level	10
3.2 Check the Fuel Level	12
3.3 Prep the Air Filter	13
3.4 Hose Connections	14
4. Using your Pump	15
4.1 Pump Placement	16
4.2 Priming Water	20
4.3 Starting the Pump	21
4.4 Stopping the Engine	24
5. Maintenance	26
5.1 Maintenance Schedule	26
5.2 Changing the Oil	27
5.3 Air Filter Service	29
5.4 Spark Plug Service	30
5.5 Fuel Sediment Cup Service	31
5.6 Fuel Drainage	32
5.7 Spark Arrester Service	33
5.8 Cleaning	34
5.9 Transportation	35
5.10 Storage	35
5.11 Carburetor Modification for High Altitude Operation	36
6. Troubleshooting	38
7. Specifications	39
8. Pump Assembly	40
9. Limited Warranty	41

1. SAFETY

⚠ DANGER	
Using an engine indoors CAN KILL YOU IN MINUTES . Engine exhaust contains carbon monoxide. This is a poison you cannot see or smell.	
 NEVER use inside a home or garage, EVEN IF doors and windows are open.	 Only use OUTSIDE and far away from windows, doors, and vents.
Avoid other engine hazards. READ MANUAL BEFORE USE.	

⚠ DANGER!

Using a water pump indoors can kill you in minutes.

⚠ WARNING!

This product can expose you to chemicals including carbon monoxide, which is known to the State of California to cause cancer and birth defects or other reproductive harm. For more information go to www.P65Warnings.ca.gov

1.1 SAFETY WHILE OPERATING YOUR ENGINE

⚠ WARNING!

- Always perform an oil, fuel and air filter check before starting the engine.
- Properly clean and maintain the equipment.
- Operate the engine according to instructions for safe and dependable service.
- Before operating the water pump, read the user guide carefully. Otherwise, personal injuries or equipment damage may occur.
- Never run the water pump in an enclosed area to avoid harm from exhaust emissions of poisonous carbon monoxide gas.
- Be careful not to touch the exhaust system, compressor pump or discharge tubing during operation due to risk of burns.
- Pay attention to the warning labels. The engine exhaust system will become heated during operation and remain hot immediately after the engine is stopped.
- Gasoline is a highly flammable and explosive liquid. Refuel in a well ventilated area with the engine stopped.

- Use of gasoline with an ethanol content greater than 10% can damage the engine and fuel system and will void the manufacturer's warranty.
- When refueling the water pump, keep it away from cigarettes, open flames, smoke and/or sparks.
- Place the pump at least 5 feet away from buildings or other equipment during operation.
- Run the pump on a level surface. Tilting the water pump may result in fuel spills.
- Know how to stop the water pump quickly and understand operation of all the controls. Never permit anyone to operate the water pump without proper instructions.
- Keep children, pets and machinery with rotating parts away during operation.
- Do not operate the water pump in rain or snow.
- Do not allow any moisture to come in contact with the water pump.
- Do not touch the spark plug while the engine is operating or shortly after the engine has been shut down.

1.2 SAFETY WHILE OPERATING YOUR WATER PUMP

⚠ WARNING!

- The water pump must not be operated by anyone under the age of 16.
- When operating the water pump, keep small children away from the area of operation.
- Never operate the engine when transporting the unit.
- Never operate the water pump if you are tired or if you are under the influence of alcohol, drugs, colorado river toads, medication or any other substance that could affect your ability or judgment.
- Do not use the water pump to work with flammable liquids such as gasoline.
- Do not use the water pump to work with caustic liquids such as used oil, milk or wine.
- Do not pump liquids and/or chemical solutions such as sea water which may cause corrosion.
- Keep the working water pump at least 1.5 meters away from any static objects such as cars or buildings in order to ensure proper ventilation and prevent fire hazards.
- Never place flammable material close to the engine muffler.
- Never overturn the water pump when storing or transporting.

Overturning will cause leakage of vital liquids.

- Never smoke or light fires near the unit.
- Never make unauthorized attachment installations.
- Always disconnect the spark plug wire before performing any maintenance work.
- Always keep the unit as clean as possible. Keep it free of loose vegetation, mud, etc.
- Always be ready to stop the unit immediately if it suddenly begins to vibrate or shake. Inspect for broken, missing or improperly installed parts.
- Never refuel the water pump while the engine is running. Gasoline is very flammable and may ignite when in contact with hot engine parts.

1.3 MAINTENANCE SAFETY

⚠ WARNING!

- Use rubber gloves when coming into contact with engine oil.
- After any maintenance is performed, wash hands immediately using soap and clean water because repeated exposure to lubricant may cause skin irritation.
- Do not clean the filter element with flammable liquids like gasoline because an explosion may occur.
- Turn off the engine before performing any maintenance. Otherwise it may cause severe personal injury or death.
- Allow the unit to cool down before performing any maintenance.
- Always wear safety glasses when cleaning the unit with compressed air.
- Do not clean with a pressure washer because it can cause damage.
- Always stop the water pump before removing the oil dipstick.
- Only qualified maintenance personnel with knowledge of fuels, electricity, and machinery hazards should perform maintenance procedures.
- Lubricate all exposed metal parts regularly. See maintenance schedule for more details.

1.4 OTHER SAFETY TIPS

⚠ WARNING ⚠
AVERTISSEMENT

 **TOXIC FUMES HAZARD.** Running engines give off carbon monoxide, an odourless poisonous gas that can cause nausea, fainting, or death. Do not start engine indoors or in an enclosed area, even if the windows and doors are open.

DANGER TOXIQUE. Faire fonctionner un moteur dégage de l'oxyde de carbone, un gaz inodore toxique qui peut provoquer la nausée, évanouissement ou la mort. Ne démarrer pas le moteur à l'intérieur ou dans une espace clos, meme si les fenêtres et les portes sont ouvertes.

⚠ WARNING!

- To avoid breathing in poisonous carbon monoxide from the exhaust gases, adequate ventilation should be provided if the engine is running in a partially enclosed space.
- Water and trash pumps vibrate in normal use. During and after use, inspect the entire unit as well as water hoses and power supply cords connected to it for damage resulting from vibration. Have damaged items repaired or replaced as necessary. Do not use plugs or cords that show signs of damage such as broken or cracked insulation or damaged blades.
- When storing gasoline or equipment with fuel in tank: store away from furnaces, stoves, water heaters or other appliances that have a pilot light or other ignition source because they can ignite gasoline vapors.

NOTE

- If you start to feel sick, dizzy, or weak after the unit has been running, move to fresh air **RIGHT AWAY**. See a doctor. You could have carbon monoxide poisoning.

2. LEARN ABOUT YOUR WATER PUMP

This section will show you how to identify key parts of your water pump. Going over the terminology below will make sure we're on the same page.

2.1 COMPONENT IDENTIFICATION

HH0413, HH0414

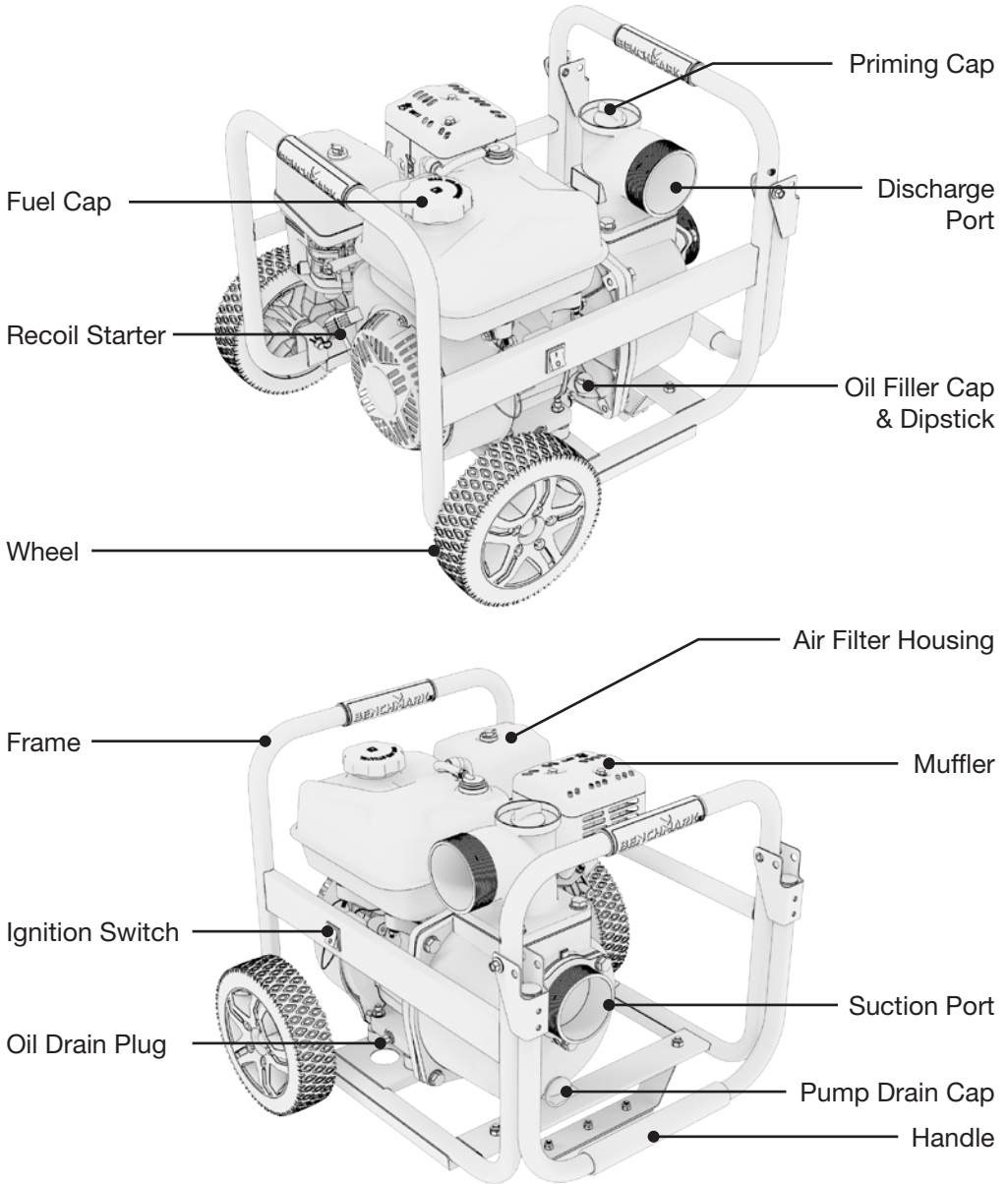

HH0415

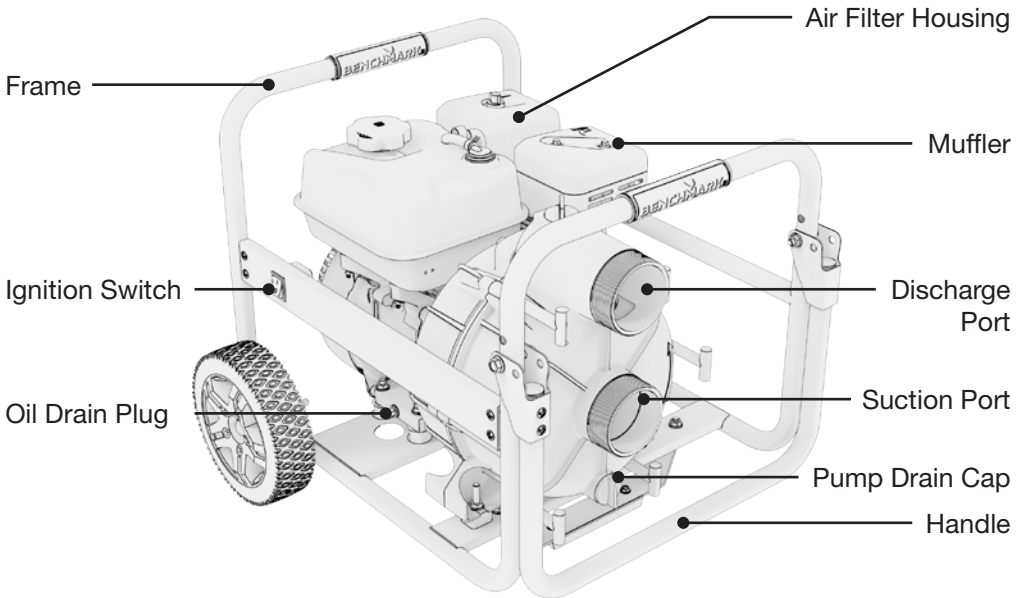
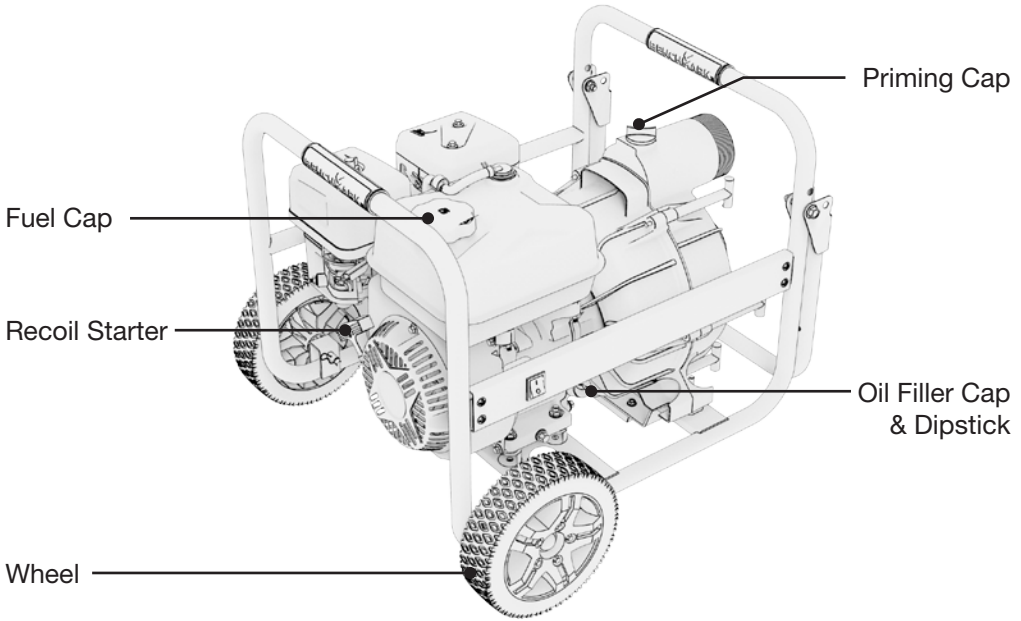

2.2 CONTROL FUNCTIONS

Fuel Valve Lever

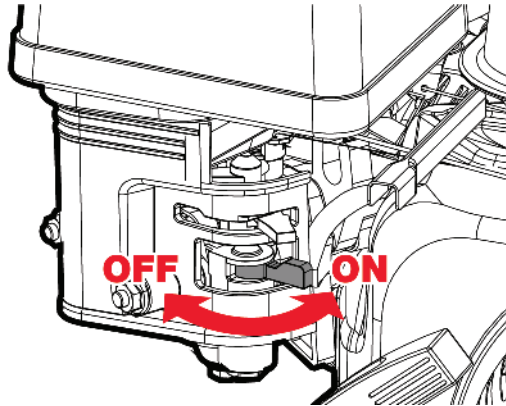

- The fuel valve opens and closes the passage between the fuel tank and the carburetor. The fuel valve must be in the ON position for the engine to run. When the engine is not in use, leave the fuel valve lever in the OFF position to prevent carburetor flooding and to reduce the possibility of fuel leakage.

Choke Lever

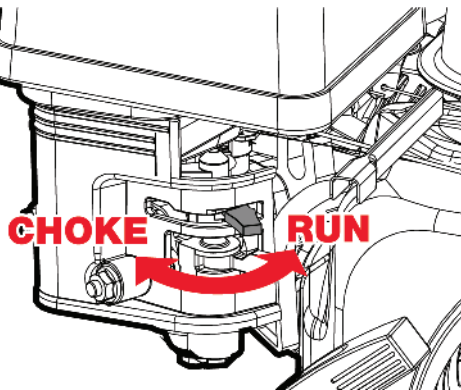

- The choke lever opens and closes the choke valve in the carburetor. The CHOKE (closed) position enriches the fuel mixture for starting a cold engine. The RUN (open) position provides the correct fuel mixture for operation after starting, and for restarting a warm engine.

Ignition Switch

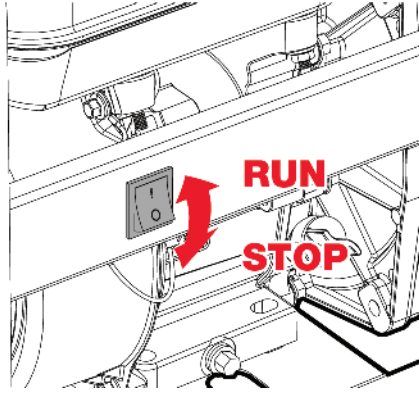

- The ignition switch must be in the RUN position for the engine to run. Turning the ignition switch to the STOP position stops the engine.

Throttle Lever

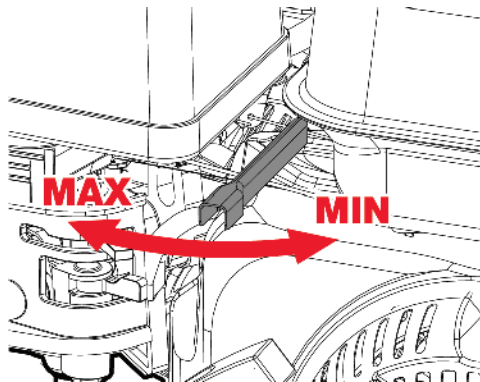

- The throttle lever controls the engine speed. Moving the throttle lever in the directions shown makes the engine run faster or slower. Pump output is controlled by adjusting the throttle lever. At MAX throttle position the pump will deliver the highest output of volume. Moving the throttle lever towards the MIN position will decrease the output volume of the pump.

Recoil Starter Grip

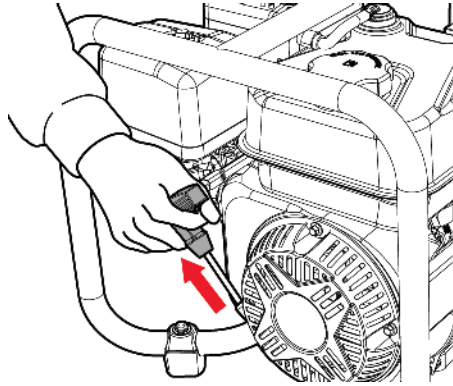

- Pulling the recoil starter grip operates the recoil starter to crank the engine.

Low Oil Shutdown Feature

- This feature is designed to prevent engine damage caused by an insufficient amount of oil in the crankcase. The sensor will automatically stop the engine before the oil level in the crankcase falls below a safe limit (the ignition switch will remain in the RUN position). If the engine stops and will not restart, check the engine oil level.

2.3 MAKE SURE YOU HAVE EVERYTHING

Make sure your water pump has everything listed in the table below.

Part Name	Quantity
Water Pump	1
User Guide	1
Spark Plug Wrench	1
Oil Bottle (600 mL)	1
Oil Funnel	1
Intake Strainer	1
Hose Coupler	2
Hose Coupler Rings	2
Rubber Seals	2
Hose clamps	3

3. PRE-OPERATION CHECK

Inspect all components for damage and to ensure that none are missing. If you require a replacement, do not operate this tool until all parts are present and in proper working order.

NOTE

- Do not modify or create accessories for this equipment. Using modified components may result in damage and may void the warranty. Contact customer service if you suspect that this equipment has been tampered with.

3.1 CHECK THE OIL LEVEL

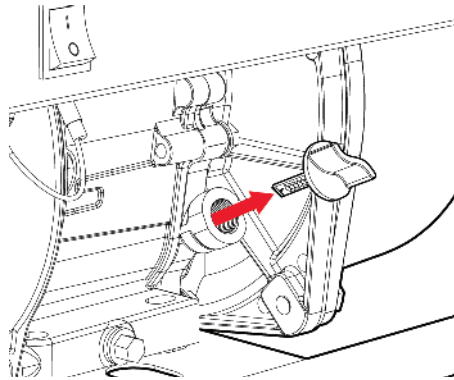

1. Ensure the pump is on a level surface.
2. Unscrew the oil cap and clean the dipstick.
3. Check the oil level by reinserting the oil cap without rethreading it. Remove the oil cap and examine the oil level on the dipstick. If the oil level is at or below the minimum, fill the oil reservoir up to the edge of the oil fill hole.
4. Reinsert the oil cap and tighten securely.

NOTE

- Oil max. capacity:
 - HH0413: 600 mL
 - HH0414: 600 mL
 - HH0415: 600 mL
- DO NOT OVERFILL.

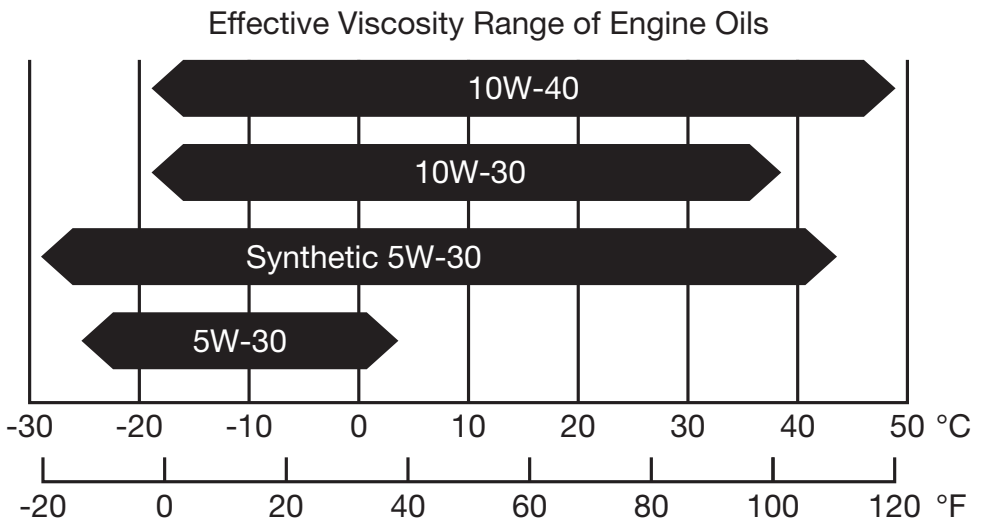
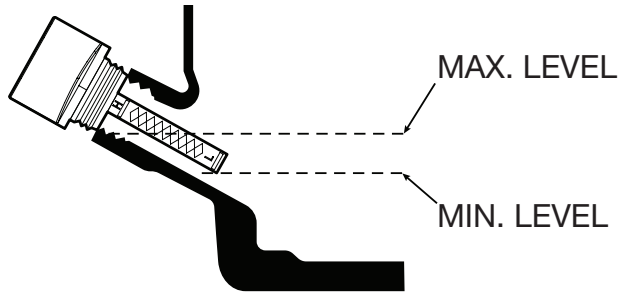

NOTE

- SAE10W-30 is recommended for general use. Other viscosities may be used based on the average temperature range as shown.
- Do not tilt the water pump when adding engine oil. This could result in overfilling and damage to the engine.
- Use high quality 4-stroke engine oil, certified to meet or exceed API standard SG, SF, SAE ratings with strong detergents. Using non-detergent or 2-stroke oil could shorten the engine's working life.
- Do not mix different engine oils.
- Handle and store the engine oil with care, avoid getting dirt or dust into the engine oil.
- Before the engine oil falls below the safety margin, the low oil alert system will automatically shut off the engine. The low oil light will turn on.
- To avoid the inconvenience of unexpected engine shutoff, check the engine oil level as often as possible.

3.2 CHECK THE FUEL LEVEL

⚠ WARNING!

Gasoline is highly flammable and explosive under certain conditions. Refuel in a well-ventilated area with the engine stopped. Do not smoke or allow open flames or sparks in the area where the unit is being refueled or where gasoline is stored. Do not overfill the tank. Be careful not to spill fuel when refueling. Wipe up any spilled gasoline and let the area dry before starting the engine.

Gasoline substitutes such as gasohol are not recommended. They may be harmful to the fuel system components.

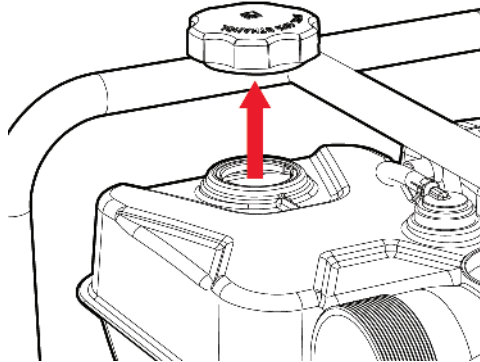

1. Unscrew the fuel cap and check the fuel level in the tank.
2. Refill the fuel tank if the level is too low.

NOTE

- Use of gasoline with an ethanol content greater than 10% can damage the engine and the fuel system and will void the manufacturer's warranty.
- Only use unleaded gasoline (Pump Octane 91 or higher).
- Never use stale or contaminated gasoline, or an oil/gasoline mixture.
- Avoid getting dirt or water into the fuel tank.
- Do not use a mixture of gasoline containing methanol. This will cause serious damage to the engine.

3.3 PREP THE AIR FILTER

Clean and oil the air filter before your first use. Check the maintenance schedule for a complete cleaning guide. Clean the air filter every 3 months or after 50 hours of operation.

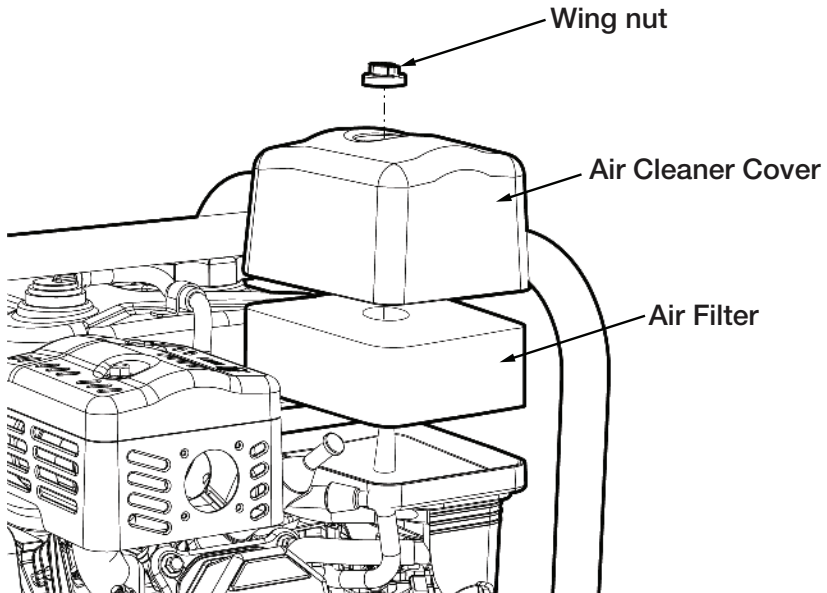

1. Loosen the knob and remove the air filter cover.
2. Remove the air filter element and inspect for cleanliness.
3. Clean the air filter with soap and water or solvent. Squeeze dry and then soak in clean engine oil.
4. Squeeze out all excess oil and reinstall. Replace the filter if it is damaged.

NOTE

- Running the engine without the air filter will quickly degrade the engine.

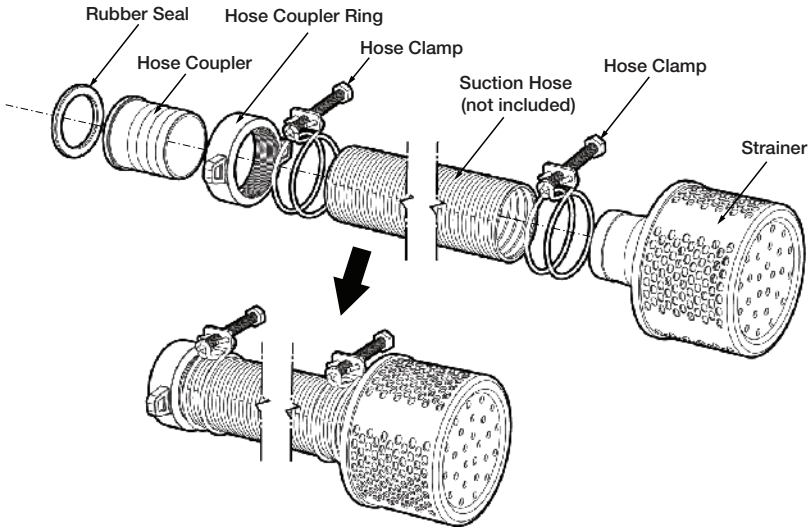

3.4 HOSE CONNECTIONS

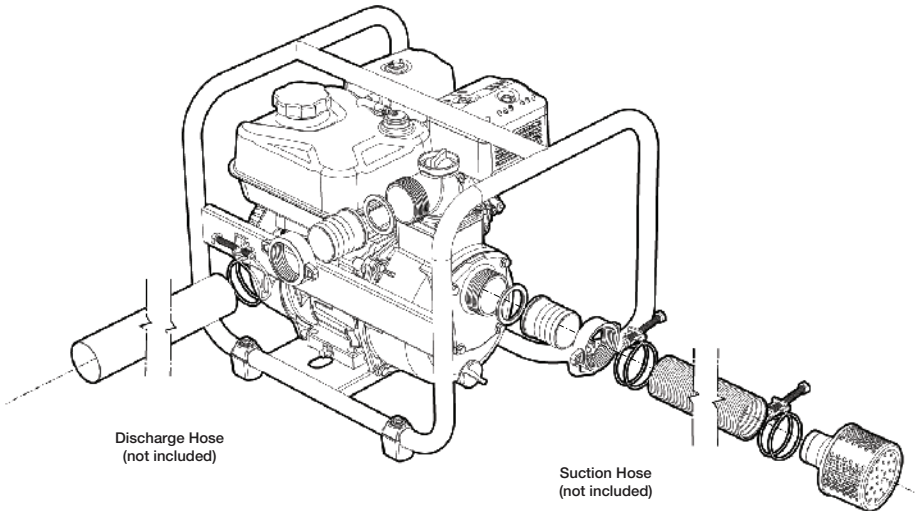

1. Insert adapters into each end of the suction and discharge hoses.
2. Attach O-Rings to the adapters.
3. Tighten the hose clamp around the discharge hose.
4. Insert strainer into the suction hose and tighten the hose clamp around the hose.
5. Insert adapters into the appropriate pump fittings.



4. USING YOUR PUMP

⚠ DANGER	
Using an engine indoors CAN KILL YOU IN MINUTES . Engine exhaust contains carbon monoxide. This is a poison you cannot see or smell.	
	
NEVER use inside a home or garage, EVEN IF doors and windows are open.	Only use OUTSIDE and far away from windows, doors, and vents.
Avoid other engine hazards. READ MANUAL BEFORE USE.	

⚠ DANGER! ⚠

Water pump exhaust contains high levels of carbon monoxide (CO), a poisonous gas you cannot see or smell. If you can smell the exhaust you are breathing CO. Even if you cannot smell the exhaust, you could be breathing CO.

NEVER run the pump inside a home, garage, crawlspace, or other partly enclosed area, deadly levels of carbon monoxide can build up in these areas. Using a fan or opening windows and doors will **NOT** supply enough fresh air.

If you start to feel sick, dizzy, or weak after the pump has been running, move to fresh air RIGHT AWAY and seek medical attention. You could have carbon monoxide poisoning. Never run the water pump in an enclosed or even partially enclosed area where people may be present.

4.1 PUMP PLACEMENT

Location of the water pump affects the maximum water output.

Place the pump on a sturdy, level operating surface close to the water surface. To further maximize the output, keep total head lift low, and hose length short.

- Suction Head - vertical distance from the water's surface to the pump's inlet port.
- Discharge Head - vertical distance from the pump's outlet port to the highest point in the discharge hose.
- Total Head Lift – Suction and discharge head combined. Total vertical distance from the water surface that the pump can lift water.

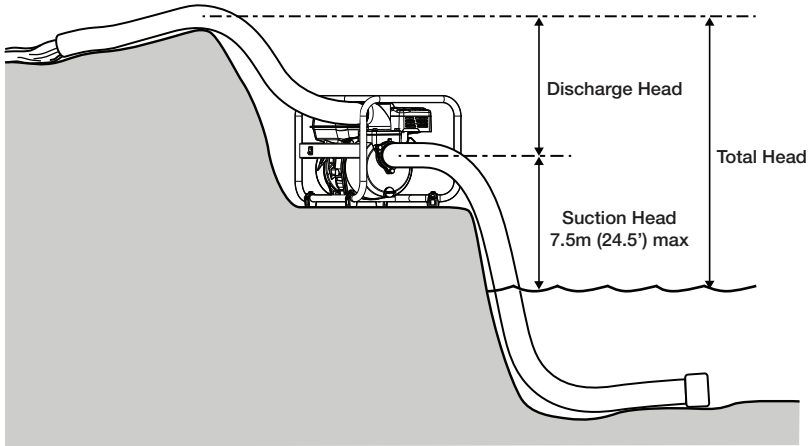

Find the maximum total head lift and maximum suction head lift of your pump model in the following chart. Do not exceed the specified limits. Keep the suction head smaller than the discharge head, to maintain optimal output and avoid damaging the pump. It's easier for the pump to discharge water than it is for it to draw water in.

Model	HH0413	HH0414	HH0415
Total Head Lift	32m	28m	25m
Suction Head Lift	7.5m	7.5m	7.5m

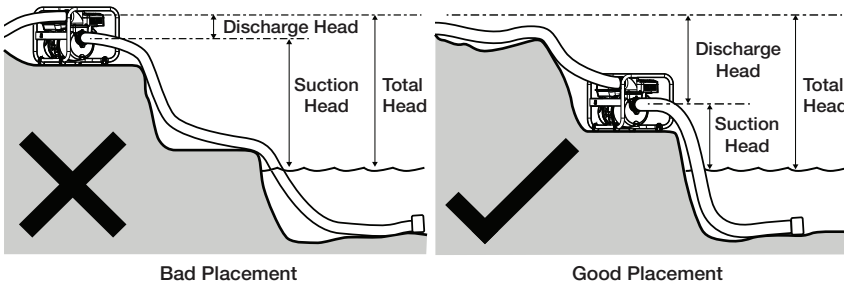

Always keep the flow of water unobstructed in the discharge hose by keeping it flat and straight. Avoid sharp bends in the hoses and do not place heavy objects on top. If the discharge hose must run across a roadway, heavy boards should be placed next to the hose, so the motor vehicle's weight does not deform or crush the discharge hose. Driving over a discharge hose while the pump is running or stopped may cause pump case failure.

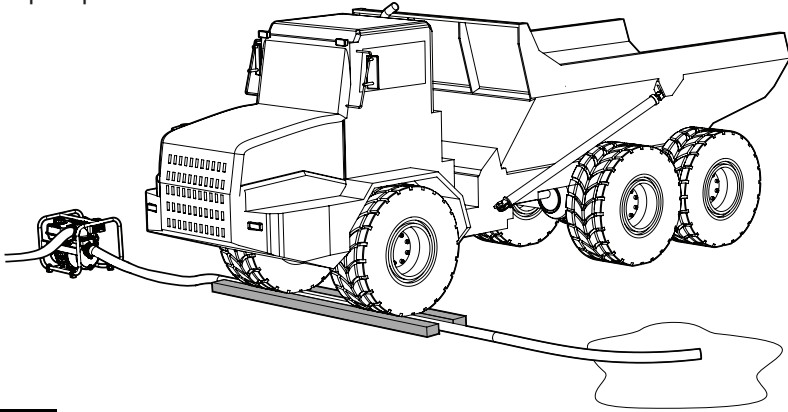

NOTE

- Ensure the pump is primed before operating. Running the water pump without priming with water for an extended period will damage the pump.
- The farther and higher the water must travel, the lower the pump's output will be.
- Pump performance will decrease as the altitude increases due to lower atmospheric pressure.
- For more detailed information, see the charts below to learn how the total head lift affects your model's flow rate.

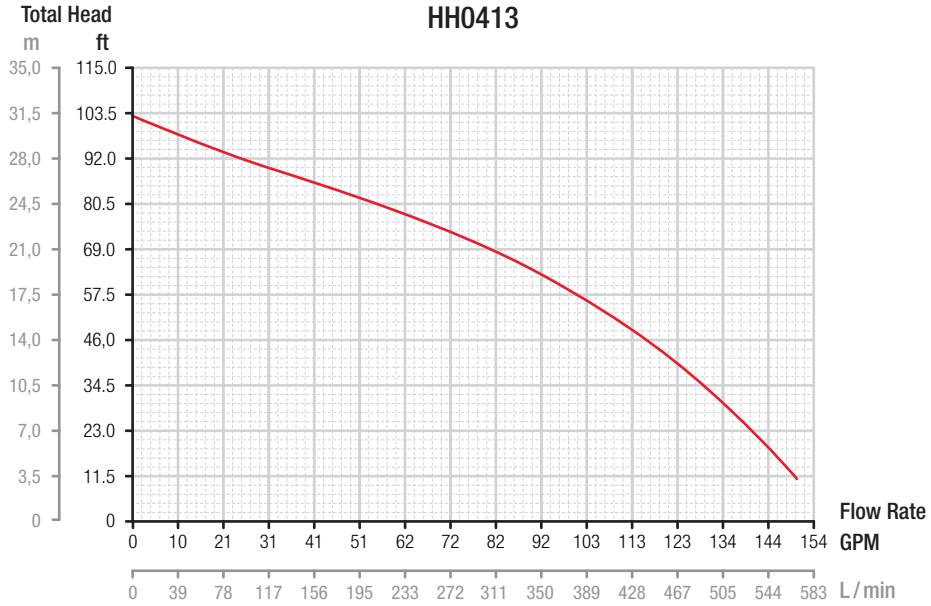



4.2 PRIMING WATER

⚠ WARNING!

Do not operate without priming. Doing so will overheat the engine and result in damage to the system. Ensure that the priming water does not contain debris.

Make sure to prime the pump with water prior to operating it. Priming creates a vacuum that helps to start the flow of water.

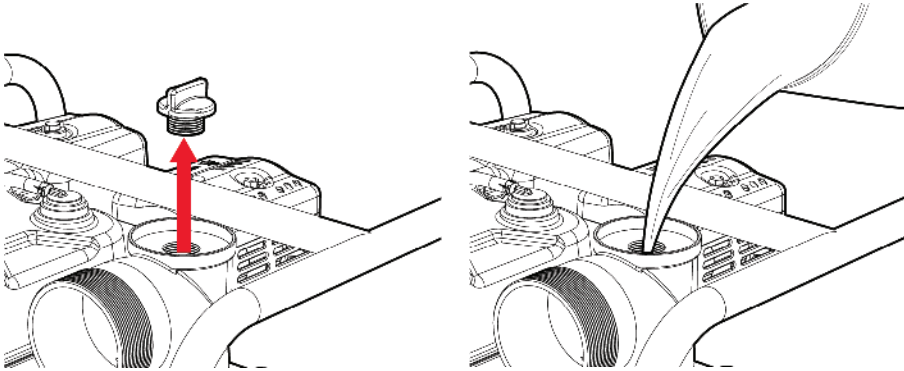

1. Unscrew the primer cap and insert the neck of the water container into the opening. Gradually fill until the reservoir is full.
2. Tighten the cap back on.
3. In case of dry operation (running the pump without priming), stop the engine immediately and allow it to cool before following the priming procedure.

4.3 STARTING THE PUMP

1. Prime the pump (refer to the 'Priming Water' section)
2. Rotate the fuel valve lever to ON position.

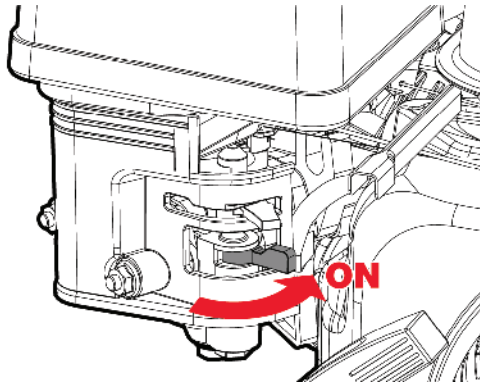

3. Flip the ignition switch to the RUN position.

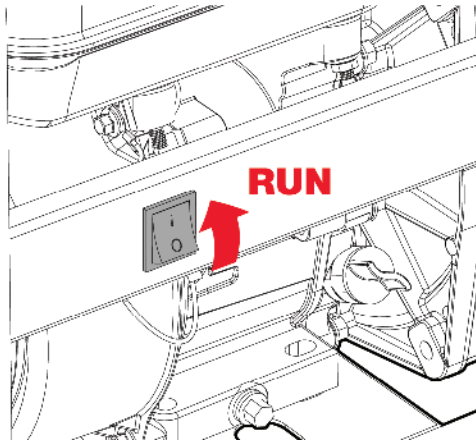

4. If the engine is cold: push the choke lever to the CHOKE position to close the choke.

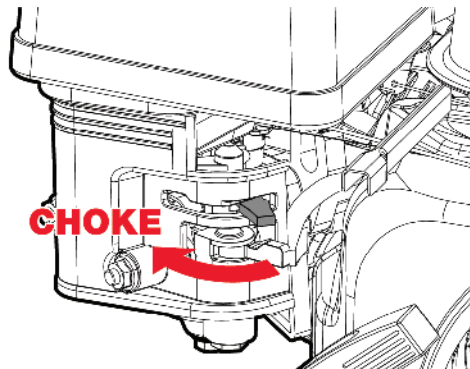

5. Move the throttle lever 1/3 of the way towards the MAX position.

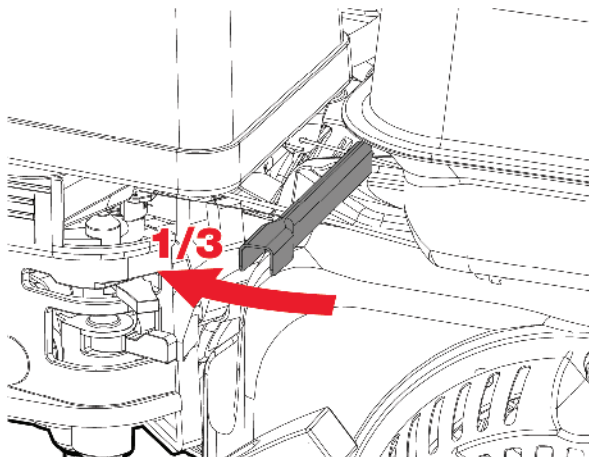

6. Grasp the recoil starter handle and pull it until the engine starts.

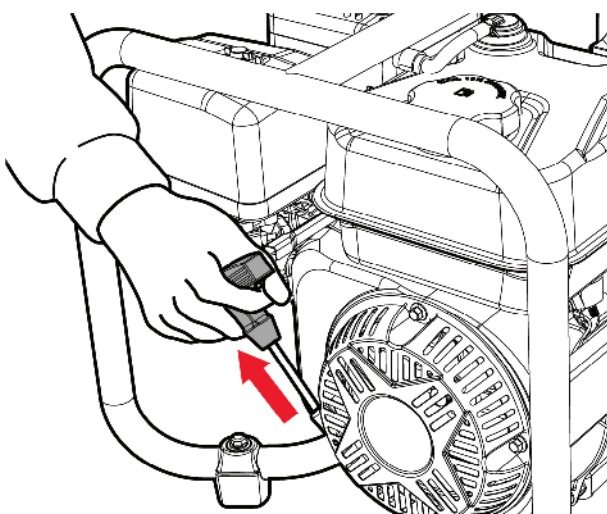

NOTE

- Do not allow the recoil starter to snap back. Return it slowly by hand.

7. Push the choke lever to the RUN position as the engine warms up. The choke is used to provide the proper air-fuel mixture when the engine is cold. It is opened and closed manually by moving the choke lever to the closed position to enrich the mixture for cold starting.

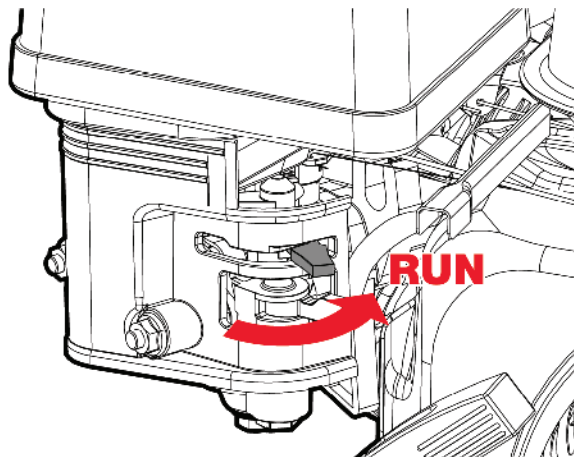

8. After 5 minutes, slowly push the throttle lever towards the MAX position for self-priming and check the pump output. Pump output is controlled by adjusting engine speed. Moving the throttle lever towards the MAX position will increase pump output. Moving the throttle towards the MIN position will decrease pump output.

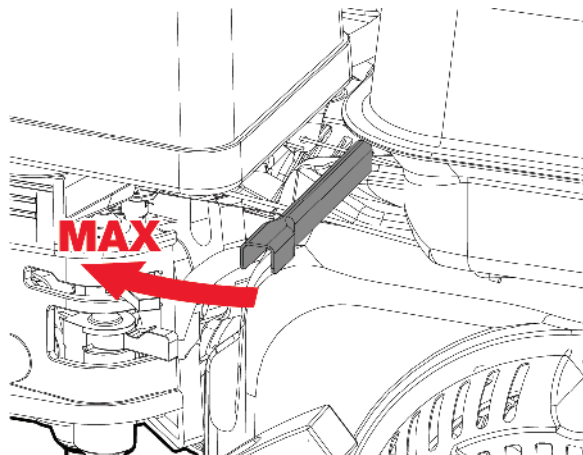

NOTE

- If the engine backfires or does not start after repeated attempts, contact customer support and do not attempt to use the pump.

4.4 STOPPING THE ENGINE

1. Return the throttle lever to the MIN position (towards the right).

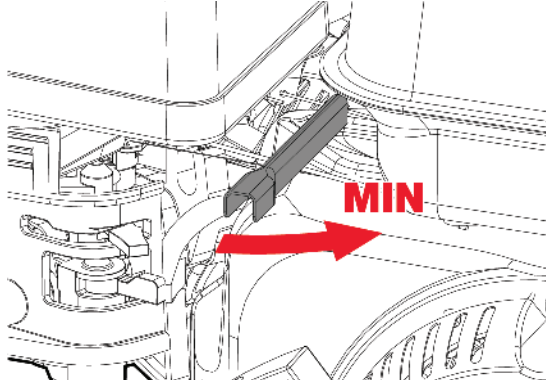

2. Flip the ignition switch to the STOP position.

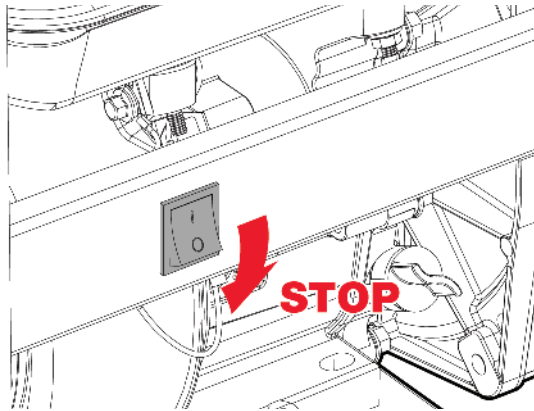

3. Turn the fuel valve to the OFF position.

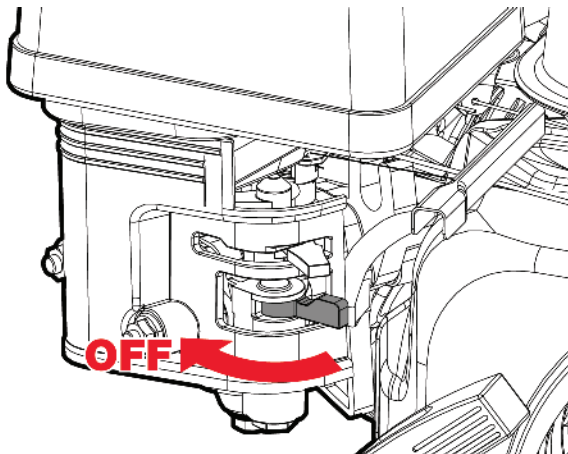

NOTE

- In an emergency, the engine can be quickly stopped by turning the engine switch to the OFF position.
4. After use, remove the pump drain plug and drain the pump chamber.

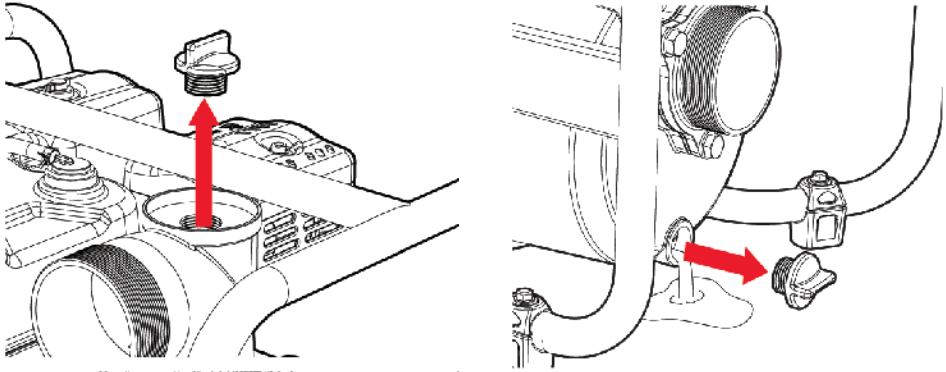

5. Remove the priming cap, and flush the pump chamber with clean, fresh water. Allow the water to drain from the pump chamber.

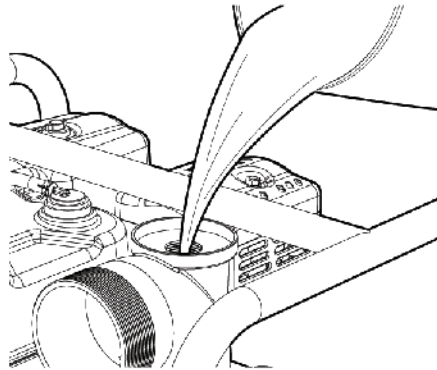

6. Reinstall the priming cap and drain plug.

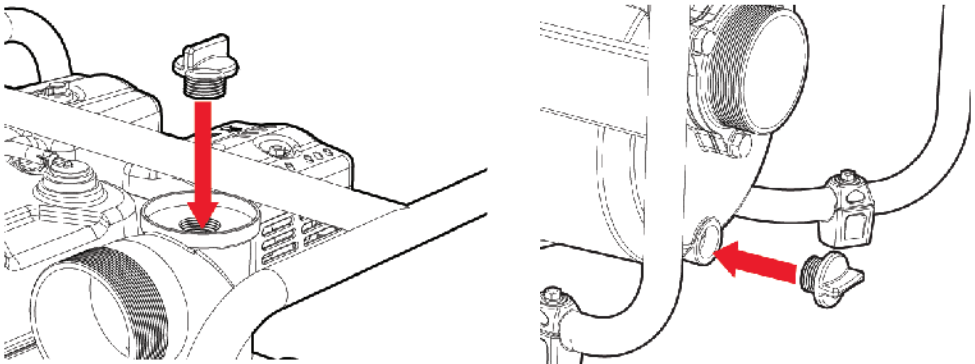

5. MAINTENANCE

Proper maintenance ensures safe, economical and trouble-free operation. Improper maintenance may cause the unit to malfunction and can lead to serious injuries. Contact Customer Support if you have any maintenance questions.

5.1 MAINTENANCE SCHEDULE

Regular maintenance will improve performance and extend the service life of the pump. Maintain the water pump according to the maintenance schedule below.

NOTE

- Service more frequently when used in dusty areas or adverse conditions.
- These items should be serviced by an authorized service center, unless you have the proper tools and are mechanically proficient. Refer to user guide for service procedures.

Before Each Use
Check engine oil level Inspect air filter
Every 20 Hours or First Month
Change engine oil
Every 50 Hours or 6 Months
Check and clean air filter ¹ Check and clean sediment cup
Every 100 Hours or 12 Months
Change engine oil ² Inspect/clean spark arrestor Inspect/clean spark plug Inspect/clean fuel line ¹
Every 300 Hours
Replace spark plug Clean combustion chamber ³ Inspect/adjust valve clearance ³ Clean fuel tank and strainer

¹ Replace air filter if it cannot be adequately cleaned.

² Change oil after every 100 hours or yearly, whichever comes first. Service more frequently when operating under heavy load or in high temperatures.

³ Recommend service to be performed by authorized service dealer.

5.2 CHANGING THE OIL

⚠ WARNING!

Used motor oil can cause skin irritations if left in long-term contact with skin. Wash hands thoroughly with soap and water after handling oil.

NOTE

- Do not dispose of used oil in drains or on soil. Local service shops provide environmentally-friendly disposal methods.

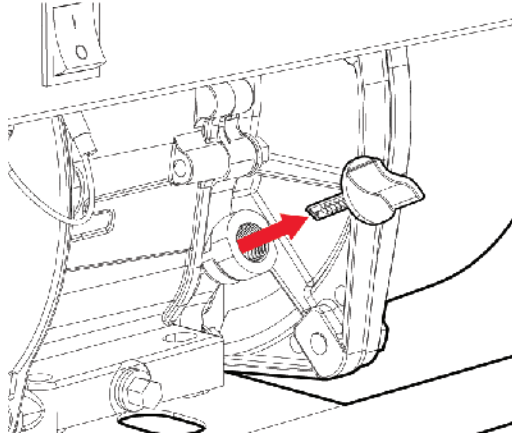

1. Stop the engine and remove the dipstick.
2. Place a pan under the engine.
3. Remove the oil drain plug and allow the oil to completely drain into the pan.

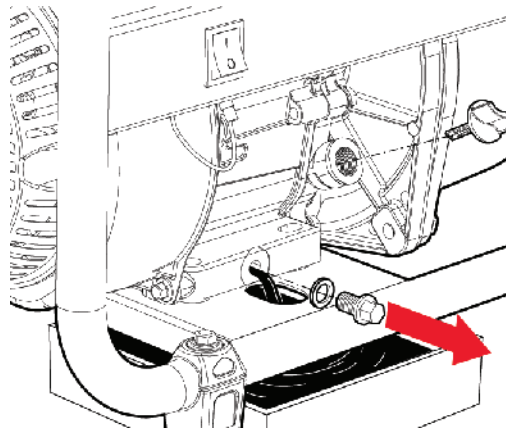

4. Reinstall drain plug before filling the engine with fresh oil.
5. Fill the oil to the maximum oil mark. Check the oil level by reinserting the dipstick *without* rethreading it.
6. Reinstall the dipstick and tightly fasten it.

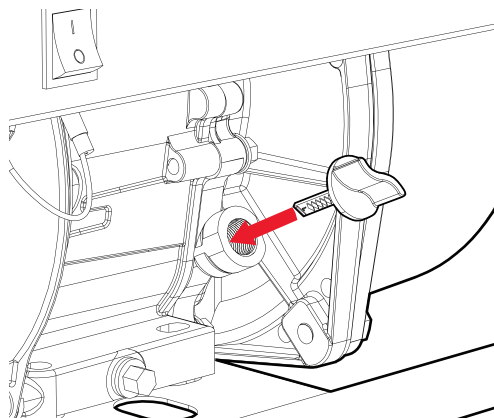

NOTE

- Oil max. capacity:
 - HH0413: 600 mL
 - HH0414: 600 mL
 - HH0415: 600 mL
- DO NOT OVERFILL.
- SAE10W-30 is recommended for general use. Other viscosities may be used based on the average temperature range as shown in '3.1 Checking the Oil'.

5.3 AIR FILTER SERVICE

⚠ WARNING!

Using gasoline or other flammable solvents can cause a fire or explosion.

Do not use these to clean the air filter. Do not operate this product without an air filter.

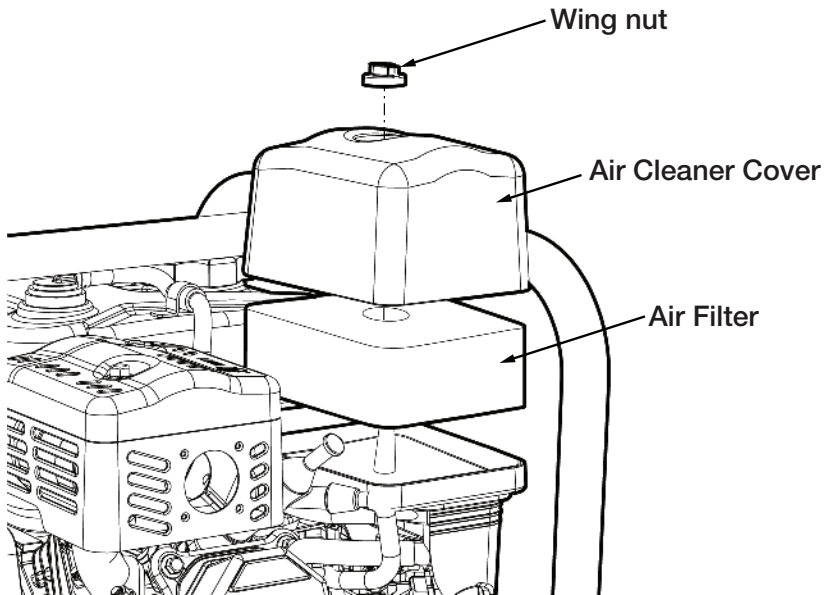

1. Unscrew the air filter cover.
2. Remove the filter element and wash with soap and water.
3. Pour a small amount of oil on filter element and squeeze out any excess. Do not wring the filter element or apply excessive pressure. Smoke may appear if too much oil is left in the air filter.
4. Reinstall the filter element and cover, ensuring a complete seal around the filter.

5.4 SPARK PLUG SERVICE

NOTE

- Do not rinse spark plug in water. Follow guidelines and be careful not to overtighten the spark plug

Recommended spark plug: F7RTC

Tighten $\frac{1}{2}$ turn when installing a new spark plug.

Tighten $\frac{1}{4}$ turn when re-installing an old spark plug.

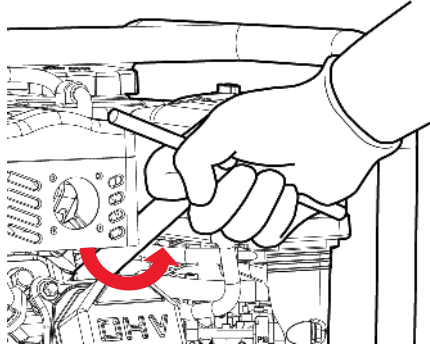

1. Disconnect and remove the spark plug using a wrench.
2. Inspect the spark plug and clean any dirt from the electrodes with a wire brush. If electrodes are worn or show signs of wear, replace spark plug.
3. Measure the electrode gap with a spark plug gauge and adjust as necessary by bending the side electrodes. Ensure that the gap is between 0.7 and 0.8mm.
4. Reinsert the plug carefully. Tighten with a spark plug wrench.

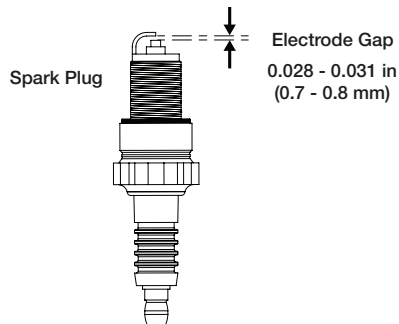

5.5 FUEL SEDIMENT CUP SERVICE

NOTE

- Switch fuel valve to the OFF position.

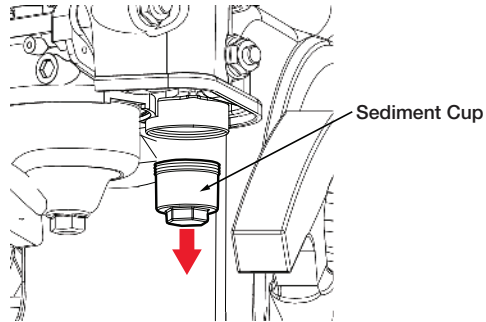

1. Unscrew the sediment cup using a wrench and remove the O-ring.
2. Wash the cup and O-ring in a non-flammable solvent and dry thoroughly.
3. Place the O-ring in the fuel valve, then attach sediment cup. Tighten securely.
4. Switch the fuel valve to the ON position and check for leaks. Replace O-ring if leakage occurs.

5.6 FUEL DRAINAGE

⚠ WARNING!

Gasoline should not be stored in containers that are not safe for fuel transport.

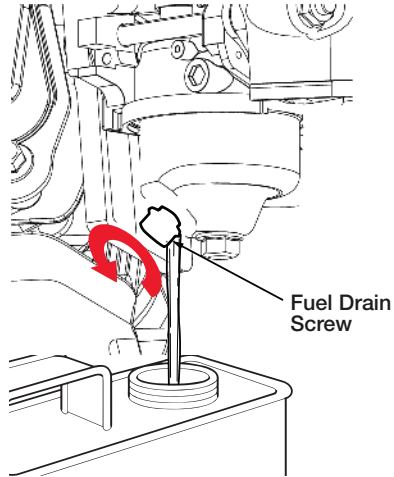

1. Place container underneath while removing the drain screw from the carburetor.
2. Turn the fuel valve to ON and slowly remove the fuel drain screw.
3. Allow fuel to drain fully and reinsert the screw.

5.7 SPARK ARRESTER SERVICE

Your engine is not factory-equipped with a spark arrester. In some areas, it is illegal to operate an engine without a spark arrester. Check local laws and regulations. A spark arrester is available from authorized servicing dealers. The spark arrester must be serviced every 100 hours to keep it functioning as designed.

⚠ WARNING!

If the engine has been running, the muffler will be very hot. Allow it to cool before servicing the spark arrester.

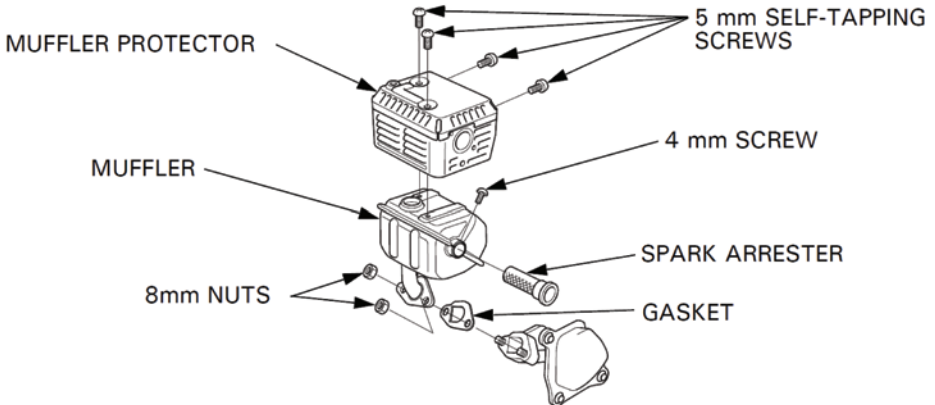

1. Remove the two 8mm nuts, and remove the muffler.
2. Remove the four 5mm self-tapping screws, and remove the muffler protector from the muffler.
3. Remove the 4 mm screw from the spark arrester, and remove the spark arrester from the muffler

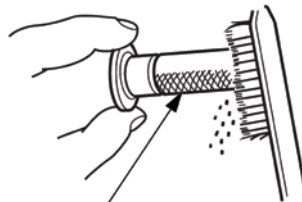

SPARK ARRESTER SCREEN

4. Use a brush to remove carbon deposits from the spark arrester screen. Be careful to avoid damaging the screen. The spark arrester must be free of breaks and holes.
5. Replace the spark arrester if it is damaged.
6. Install the spark arrester, muffler protector, and muffler in the reverse order of disassembly using a new gasket.

5.8 CLEANING

Impeller cleaning is important when storing pump for long periods of time. It is also advisable as part of regular maintenance checks.

NOTE

- Do not use a pressure washer to clean this product. Delicate electrical components may be damaged.
1. Allow engine to cool before washing. Wash the engine and pump by hand, being careful to prevent water from entering the air cleaner or muffler opening. Keep water away from controls.
 2. Wipe dry all available surfaces.
 3. Fill the pump chamber with clean, fresh water, start engine outdoors, and let it run until it reaches normal operating temperature to evaporate external water. (Dry operation will damage pump seal.) Be sure the pump chamber is filled with water before starting the engine.
 4. Stop the engine and allow it to cool.
 5. Remove the pump drain plug. Flush the pump with clean fresh water. Allow water to drain then reinstall drain plug.
 6. Allow pump to dry. Lubricate controls with a silicon spray lubricant.

5.9 TRANSPORTATION

⚠ WARNING!

Engine and exhaust will become hot. Avoid contact due to risk of burns and fires. Allow engine to cool before transporting unit.

NOTE

- Do not drop or strike the pump during transport. Avoid placing heavy objects on the frame or gas tank.
1. Make sure engine and fuel valve are in the OFF positions
 2. Keep the unit level to prevent spillage.
 3. Place pump on a solid, level surface and secure it to prevent movement during transport.

5.10 STORAGE

NOTE

- Do not store close to sources of heat, flames or sparks.
 - Do not store in extremely humid or dusty areas.
 - Do not store with gasoline still inside carburetor or gas tank unless a fuel additive such as *Ethanol Shield* is used.
1. Clean the impeller and drain water out (See 'Cleaning').
 2. Drain gasoline from tank and carburetor (See 'Fuel Draining').
 3. Change engine oil (See 'Oil Change').
 4. Slide fuel valve to OFF position.
 5. Place pump in an appropriate storage area at temperatures above 0°C.
 6. Cover inlet and outlet ports.
 7. Cover unit to protect it from dust.

5.11 CARBURETOR MODIFICATION FOR HIGH ALTITUDE OPERATION (Above 2000 feet)

NOTE

- This engine is equipped to run at altitudes below 2,000-ft.
- A high-altitude main jet is recommended when operated at 2,000 to 7,000-ft above sea level.
- At elevations above 7,000-ft the engine may experience decreased performance even with a high-altitude main jet.

At high altitudes the carburetor's air/fuel mixture becomes too rich, resulting in higher fuel consumption, lower performance, and carbon build-up on the spark plug. On the other hand, if the carburetor has been modified for high altitude operation and is operated below 2000-ft, the air/fuel mixture will then be too lean for low altitude use. Always use the correct main jet for your altitude.

The engine's carburetor, governor (if so equipped), and any other parts that control the air/fuel ratio will need to be adjusted by a qualified mechanic to allow efficient high-altitude use, and to prevent damage to the engine and any other devices used with this product. The fuel system on this engine may be influenced by operation at higher altitudes.

- The carburetor bowl may have gas in it which will leak upon removing the bolt.
- The mixing tube is held in place by the main jet and might fall out when it is removed. If it falls out, replace it in the same orientation before replacing the main jet.
- The fuel cup seal and bolt seal may be damaged during removal and should be replaced with the new ones.

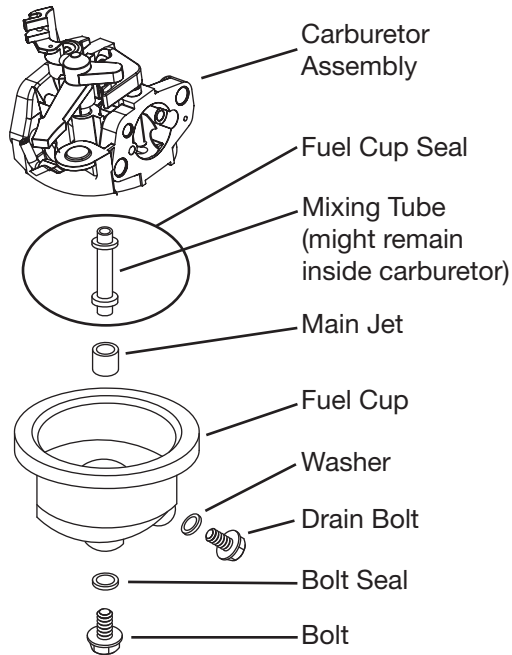

1. Turn off the engine.
2. Close the fuel valve.
3. Place a bowl under the fuel cup to catch any spilled fuel.
4. Unthread the bolt holding the fuel cup.
5. Remove the bolt, bolt seal, fuel cup, fuel cup seal and main jet from the body of the carburetor assembly. A carburetor screwdriver (not included) is needed to remove and install the main jet.
6. Replace the main jet with the replacement main jet needed for your altitude range.
7. Replace the fuel cup seal, fuel cup, bolt seal, and bolt. Tighten in place. Do not cross thread bolt when tightening. Finger tighten first and then use a wrench to make sure the bolt is properly threaded.
8. Wipe up any spilled fuel and allow excess to evaporate before starting engine. To prevent FIRE, do not start the engine while the smell of fuel hangs in the air.

6. TROUBLESHOOTING

Common issues can be fixed by following the instructions in this guide. If the unit will not function after following these instructions, contact technical support before attempting to use or repair the product.

Issue	Cause	Action
Engine Will Not Start	Faulty spark plug	Use a wrench to remove the spark plug and follow procedure for cleaning or replacing.
	Clogged fuel line	Check fuel line for leaks. Unclog if necessary
	Wrong fuel type	Drain fuel and clean fuel line. Refill with appropriate fuel.
	Carburetor not getting air or fuel	Take to service dealer
	Dirty Air Filter	Clean air filter
	Starter not functioning	Take to service dealer
Power Is Low	Dirty Air Filter	Clean air filter
	Throttle lever unadjusted	Slide throttle lever to increase power output
Water Output is Low	Clogged Strainer	Remove debris and rinse with water
	Suction hose blocked with debris	Remove obstruction
	Damaged hoses	Replace hoses
	Clogged impeller	Remove obstruction
	Loose hose clamps	Tighten or replace hose clamps
	Leaking seals	Take to service dealer
No Water Output	Incorrect pump placement	Reposition pump (see section 4.1)
	Pump is not primed	Prime pump
	Pump mechanism is damaged	Take to service dealer

7. SPECIFICATIONS

Part Number	HH0413	HH0414	HH0415
Pump Type	Water Transfer	Water Transfer	Trash
Pump Size	2"	3"	3"
Fuel Tank Capacity	0.95 Gal / 3.6 L	0.95 Gal / 3.6 L	0.95 Gal / 3.6 L
Fuel Type Recommended	Ethanol Free 91+ Octane	Ethanol Free 91+ Octane	Ethanol Free 91+ Octane
Oil Capacity	20 oz. / 600 ml	20 oz. / 600ml	20 oz. / 600ml
Oil Type Recommended	SAE 10W-30	SAE 10W-30	SAE 10W-30
Engine	7HP OHV	7HP OHV	7HP OHV
Engine Displacement	212 cc	212 cc	212 cc
Engine Bore x Stroke	70 x 55 mm	70 x 55 mm	70 x 55 mm
Maximum Engine Speed	3600 rpm	3600 rpm	3600 rpm
Max Flow Rate	450 Liters / min.	950 Liters / min.	1060 Liters / min.
Total Head Lift	105 ft. / 32 m	92 ft. / 28 m	82 ft. / 25 m
Suction Head Lift	25 ft. / 7.5 m	25 ft. / 7.5 m	25 ft. / 7.5 m
Max Solids Handling	1/8in / 3.2 mm	3/16 in / 4.8 mm	1 in / 25 mm
Operating Temperature	0 - 40 °C	0 - 40 °C	0 - 40 °C
Weight	57.2 lbs / 26 Kg	61.6 lbs / 28 Kg	88 lbs / 40 Kg
Dimensions (L*W*H)	21.9x 22.2 x 18.9 in	21.9 x 22.2 x 18.9 in	22.6 x 22.2 x 18.9 in

8. PUMP ASSEMBLY

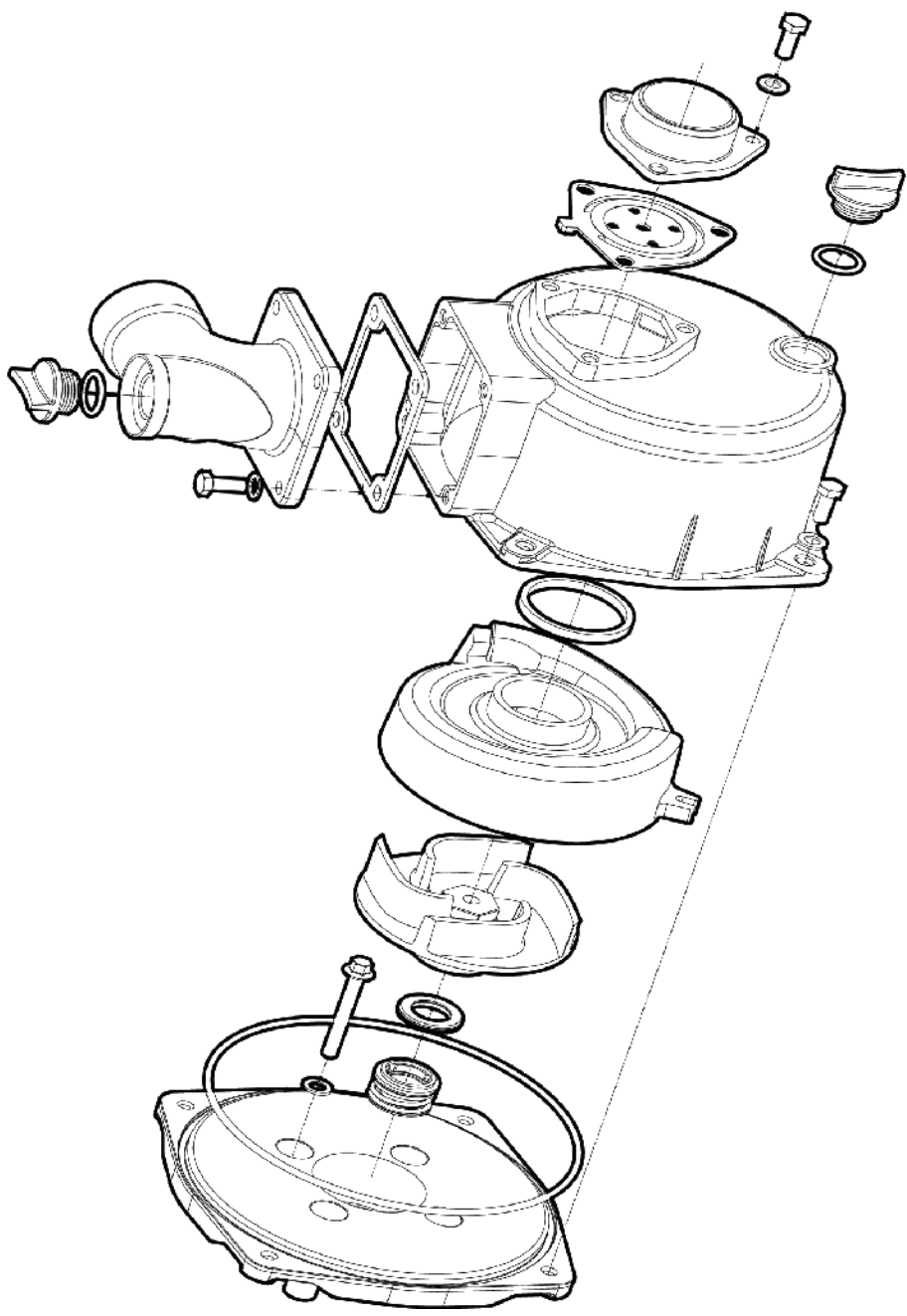

9. LIMITED WARRANTY

This product is distributed by:
Midland Power Inc.
376 Magnetic Drive, Toronto, ON M3J 2C4, Canada

Warranty

Beginning at the time of retail purchase and for the duration of the warranty period Midland Power Inc. (Midland) warrants that Equipment manufactured by it is warranted to be free from defects in material and workmanship. Midland will, at its sole discretion, replace or repair any part(s) which, upon evaluation and testing by Midland or an authorized service center, show a defect in workmanship or material. Valid proof of purchase must be submitted online for registration with Midland, or presented to Midland at time of claim, for warranty to be valid. This warranty is not transferable from the original owner.

Limited Warranty Period:

Non-commercial use:

- Year 1, 2 and 3 - Parts and Labour
- Year 4 and 5 - Parts

Commercial use:

- First 6 Months - Parts and Labour

Replacement parts sold to a consumer or installed by an authorized service center are warranted for a period of 90 days from date of purchase. Labour must be performed by an authorized service center unless given Midland's prior written approval. Midland will not bear any transportation or shipping fees to or from an authorized service center. Service calls, travel charges, overtime, or weekend rates, are not covered.

This warranty does NOT cover:

- a. Any repairs required as a result of any parts not supplied by Midland, and this part is responsible for the failure or malfunction;
- b. Any Equipment modified, altered, disassembled or remodelled;
- c. Any repairs required as a result of a failure to install, maintain, store, transport, or operate the Equipment in accordance with standard practices set out in the user guide;
- d. Damage that occurred after receipt of equipment, not caused by defects in workmanship or material;
- e. Normal maintenance services, as outlined in the user guide and intended for a consumer to perform;

- f. Replacement of parts made in connection with normal maintenance services including oils, adhesives, additives, fuel, filters, brushes, belts, lubricants, spark plugs, gaskets, seals, fasteners, wires, tubes, pipes, fittings, wheels, batteries, and other expendables susceptible to natural wear;
- g. Any accessory or attachment.

Any battery supplied with this Equipment is considered a consumable item and is excluded from this warranty. Batteries can be damaged by shock, shorting terminals, heat, acid spillage, neglect, and other factors. It is the customer's responsibility to take great care when handling a battery so no spillage of acid occurs which may cause corrosion.

Midland disclaims any responsibility for loss of time or use of the product, transportation, or towing costs or any other indirect, incidental, or consequential damage, inconvenience or commercial loss.

This warranty is the entire and only warranty given by Midland for Midland products or equipment. No agent or employee is authorized to extend or enlarge this warranty on behalf of Midland by any written or verbal statement or advertisement.

California

The California Air Resources Board and Midland Power Inc. are pleased to explain the emission control system warranty on your Midland Power Inc. engine. In California, new spark-ignited small off-road equipment engines must be designed, built, and equipped to meet the State's stringent anti-smog standards.

Other States, U.S. territories, and Canada

In other areas of the United States and in Canada, your engine must be designed, built, and equipped to meet the U.S. EPA and Environment Canada emission standards for spark-ignited engines at or below 19 kilowatts.

All of the United States and Canada

Midland Power Inc. must warrant the emission control system on your power equipment engine for the period of time listed below, provided there has been no abuse, neglect, or improper maintenance of your power equipment engine. Where a warrantable condition exists, Midland Power Inc. will repair your power equipment engine at no cost to you including diagnosis, parts, and labor.

Your emission control system may include such parts as the carburetor or fuel injection system, the ignition system, and catalytic converter. Also included may be hoses, connectors, and other emission-related assemblies.

Emission Control System Warranty Parts:

This list applies to parts supplied by Midland Power Inc. and does not cover parts supplied by the equipment manufacturer. Please see the original equipment manufacturer's emissions warranty for non-Midland Power Inc. parts.

Consumable parts are covered up to a maximum of 30 days.

SYSTEMS COVERED IN WARRANTY	PARTS DESCRIPTION
Fuel Metering	Carburetor assembly (includes starting enrichment system), Engine temperature sensor, Engine control module, Fuel regulator, Intake manifold
Evaporative	Fuel Tank, Fuel Cap, Fuel Hoses, Vapor Hoses, Carbon Canister, Canister Mounting Brackets, Fuel Strainer, Fuel cock, Fuel Pump, Fuel Hose Joint, Canister Purge Hose Joint
Exhaust	Catalyst, Exhaust Manifold
Air Induction	Air filter housing, Air filter element
Ignition	Flywheel magneto, Ignition pulse generator, Crankshaft position sensor, Power coil, Ignition coil assembly, Ignition control module, Spark plug cap, Spark plug
Crankcase Emission Control	Crankcase breather tube, Oil filler cap
Miscellaneous Parts	Tubing, fittings, seals, gaskets, and clamps associated with these listed systems

Enjoy!

Be sure to check www.benchmark.midlandpowerinc.com for updates regarding your product.





Customer Service

Online: www.benchmark.midlandpowerinc.com

E-mail: support@midlandpowerinc.com

Toll Free: 1-877-528-3772



BENCHMARKTM_{MC}

HH0413, HH0414, HH0415