

# BENCHMARK™ MC

## 20V MAX<sup>†</sup> BRUSHLESS TILE AND CUT-OFF SAW



ITEM #3646-007



5 Year Limited Warranty on tool



JD5312

**READ ALL INSTRUCTIONS BEFORE FIRST USE.  
KEEP THIS MANUAL FOR FUTURE REFERENCE.  
KEEP AWAY FROM CHILDREN.  
SEE NEXT PAGE FOR CRITICAL TOOL RELATED  
PRECAUTIONS.**

<sup>†</sup> Maximum initial battery voltage (measured without a load)  
is 20 volts. Nominal voltage is 18 volts.



**WEAR CSA APPROVED  
EYE PROTECTION**



**WEAR EAR  
PROTECTION**



**WEAR A  
FACE MASK**

## PRODUCT SPECIFICATIONS

20V MAX BRUSHLESS TILE AND CUT OFF SAW	
Max speed	20000 RPM (no load)
Wheel size	76 mm (3")
Max cutting capacity (with dust cover assembly installed)	22 mm (7/8")
Max cutting capacity (without dust cover assembly installed)	22 mm (7/8")
Arbor size	9.5 mm (3/8")
Tool weight	0.96 kg (2.11 lbs) 

PARTS AVAILABLE AT HOME HARDWARE	
Batteries (sold separately)	HH #5350-023 (2.5Ah) HH #5350-011 (4Ah) HH #5350-012 (5Ah)
Charger (sold separately)	HH #5350-010 (2.4A) HH #5350-022 (6A Fast)

### CRITICAL TOOL RELATED PRECAUTIONS

1. Improper discs (wrong size, material, or RPM rating) can explode under high-speed rotation, causing serious injury.
2. A loose or improperly mounted disc can detach during operation.
3. Using the wrong type of disc (e.g., grinding instead of cutting) can lead to tool damage or dangerous kickback.
4. Batteries must be fully charged before first use and must be charged/stored indoors in a cool dry environment. Exposure to temperature extremes will reduce battery performance and lifespan.

**READ ALL SAFETY, WARNING, PRECAUTIONS AND MAINTENANCE INFORMATION PROVIDED IN THIS MANUAL.**

### NEED ASSISTANCE?

- Technical questions
- Replacement parts
- Parts missing from package

Scan here for support



Email us at: [customerservice@powertoolsplus.ca](mailto:customerservice@powertoolsplus.ca)  
Call us on our toll-free customer support line:  
1-866-349-8665 (9-5pm Monday-Friday EST)





**TABLE OF CONTENTS**

Product specifications ..... 1  
Table of contents ..... 2  
General safety warnings ..... 3-6  
Service ..... 6  
Specific safety rules for 20V max brushless tile and cut off saw ..... 6-8  
Symbols ..... 9  
Know you 20v max brushless tile and cut off saw ..... 10  
Assembly and operation ..... 11-16  
Maintenance ..... 17  
Exploded view ..... 18  
Parts list ..... 19-20  
Warranty ..... 21

## GENERAL SAFETY WARNINGS

**⚠️ WARNING:** Before using this tool or any of its accessories, read this manual and follow all Safety Rules and Operating Instructions. The important precautions, safeguards and instructions appearing in this manual are not meant to cover all possible situations. It must be understood that common sense and caution are factors which cannot be built into the product.

## EYE, EAR & LUNG PROTECTION

SYMBOL	MEANING
<p><b>⚠️ DANGER</b></p> 	<p><b>ALWAYS WEAR EYE PROTECTION THAT CONFORMS WITH CSA Z94.3 or ANSI SAFETY STANDARD Z87.1</b></p> <p>FLYING DEBRIS can cause permanent eye damage. Prescription eyeglasses ARE NOT a replacement for proper eye protection. The usage of a safety standard compliant face shield placed over proper safety glasses or goggles can reduce the risk of facial injury.</p> <p><b>Non-compliant eyewear can cause serious injury if broken during the operation of a power tool.</b></p>
<p><b>⚠️ WARNING</b></p> 	<p>Use hearing protection, particularly during extended periods of operation of the tool, or if the operation is noisy.</p>
<p><b>⚠️ WARNING</b></p> 	<p><b>WEAR A DUST MASK THAT IS DESIGNED TO BE USED WHEN OPERATING A POWER TOOL IN A DUSTY ENVIRONMENT.</b></p> <p>Dust that is created by power sanding, sawing, grinding, drilling, and other construction activities may contain chemicals that are known to cause cancer, birth defects, or other genetic abnormalities. These chemicals include:</p> <ul style="list-style-type: none"> <li>• Lead from lead-based paints</li> <li>• Crystalline silica from bricks, cement, and other masonry products</li> <li>• Arsenic and chromium from chemically treated lumber</li> </ul> <p>The level of risk from exposure to these chemicals varies, according to how often this type of work is performed. In order to reduce exposure to these chemicals, work in a well-ventilated area, and use approved safety equipment, such as a dust mask that is specifically designed to filter out microscopic particles.</p>
<p><b>⚠️ WARNING</b></p> 	<p><b>TO AVOID ELECTRICAL HAZARDS, FIRE HAZARDS OR DAMAGE TO THE TOOL, USE PROPER CIRCUIT PROTECTION.</b></p> <p>The battery charger is wired at the factory for 120 V AC operations. It must be connected to a 120 V AC, 15 A circuit that is protected by a time-delayed fuse or circuit breaker. To avoid shock or fire, replace power cord immediately if it is worn, cut or damaged in any way.</p>
<p><b>⚠️ WARNING</b></p> 	<p>Ventilation openings in batteries and chargers must always be open to allow cooling air to circulate freely. Air vents that are blocked, restricted, or covered may result in the battery or charger overheating. Overheating may lead to damage to the tool or cause a fire, resulting in possible serious injury.</p>

## General power tool safety warnings

 **WARNING:** Read all safety warnings and all instructions. Failure to follow the warnings and instructions may result in electric shock, fire and/or serious injury.

**Save all warnings and instructions for future reference.**

The term “power tool” in the warnings refers to your mains-operated (corded) power tool or battery-operated (cordless) power tool.

### 1) Work area safety

- a) **Keep work area clean and well lit.** Cluttered or dark areas invite accidents.
- b) **Do not operate power tools in explosive atmospheres, such as in the presence of flammable liquids, gases or dust.** Power tools create sparks which may ignite the dust or fumes.
- c) **Keep children and bystanders away while operating a power tool.** Distractions can cause you to lose control.

### 2) Electrical safety

- a) **Power tool plugs must match the outlet. Never modify the plug in any way. Do not use any adapter plugs with earthed (grounded) power tools.** Unmodified plugs and matching outlets will reduce risk of electric shock.
- b) **Avoid body contact with earthed or grounded surfaces, such as pipes, radiators, ranges and refrigerators.** There is an increased risk of electric shock if your body is earthed or grounded.
- c) **Do not expose power tools to rain or wet conditions.** Water entering a power tool will increase the risk of electric shock.
- d) **Do not abuse the cord. Never use the cord for carrying, pulling or unplugging the power tool. Keep cord away from heat, oil, sharp edges or moving parts.** Damaged or entangled cords increase the risk of electric shock.
- e) **When operating a power tool outdoors, use an extension cord suitable for outdoor use.** Use of a cord suitable for outdoor use reduces the risk of electric shock.
- f) **If operating a power tool in a damp location is unavoidable, use a RESIDUAL CURRENT DEVICE (RCD) protected supply.** Use of an RCD reduces the risk of electric shock.

### 3) Personal safety

- a) **Stay alert, watch what you are doing and use common sense when operating a power tool. Do not use a power tool while you are tired or under the influence of drugs, alcohol or medication.** A moment of inattention while operating power tools may result in serious personal injury.
- b) **Use personal protective equipment. Always wear eye protection.** Protective equipment such as dust mask, non-skid safety shoes, hard hat or hearing protection used for appropriate conditions will reduce personal injuries.
- c) **Prevent unintentional starting. Ensure the switch is in the off-position before connecting to power source and/or BATTERY pack, picking up or carrying the tool.** Carrying power tools with your finger on the switch or energizing power tools that have the switch on invites accidents.

- d) Remove any adjusting key or wrench before turning the power tool on.** *A wrench or a key left attached to a rotating part of the power tool may result in personal injury.*
- e) Do not overreach. Keep proper footing and balance at all times.** *This enables better control of the power tool in unexpected situations.*
- f) Dress properly. Do not wear loose clothing or jewellery. Keep your hair and clothing away from moving parts.** *Loose clothes, jewellery or long hair can be caught in moving parts.*
- g) If devices are provided for the connection of dust extraction and collection facilities, ensure these are connected and properly used.** *Use of dust collection can reduce dust-related hazards.*
- h) Do not let familiarity gained from frequent use of tools allow you to become complacent and ignore tool safety principles.** *A careless action can cause severe injury within a fraction of a second.*

#### **4) BATTERY tool use and care**

- a) Recharge only with the charger specified by the manufacturer.** *A charger that is suitable for one type of BATTERY pack may create a risk of fire when used with another BATTERY pack.*
- b) Use power tools only with specifically designated BATTERY packs.** *Use of any other BATTERY packs may create a risk of injury and fire.*
- c) When BATTERY pack is not in use, keep it away from other metal objects, like paper clips, coins, keys, nails, screws or other small metal objects, that can make a connection from one terminal to another.** *Shorting the BATTERY terminals together may cause burns or a fire.*
- d) Under abusive conditions, liquid may be ejected from the BATTERY; avoid contact. If contact accidentally occurs, flush with water. If liquid contacts eyes, additionally seek medical help.** *Liquid ejected from the BATTERY may cause irritation or burns.*
- e) Do not use a BATTERY pack or tool that is damaged or modified.** *Damaged or modified batteries may exhibit unpredictable behaviour resulting in fire, EXPLOSION or risk of injury.*
- f) Do not expose a BATTERY pack or tool to fire or excessive temperature.** *Exposure to fire or temperature above 130 °C (265 °F) may cause explosion.*
- g) Follow all charging instructions and do not charge the BATTERY pack or tool outside the temperature range specified in the instructions.** *Charging improperly or at temperatures outside the specified range may damage the BATTERY and increase the risk of fire.*

#### **5) Service**

- a) Have your power tool serviced by a qualified repair person using only identical replacement parts.** *This will ensure that the safety of the power tool is maintained.*
- b) Never service damaged BATTERY packs.** *Service of BATTERY packs should only be performed by the manufacturer or authorized service providers.*

## SPECIFIC SAFETY RULES

**⚠ WARNING: Know your cordless cut off saw. Do not plug in the charger or install the battery in the tool until you have read and understand this Instruction Manual. Learn the tool's applications and limitations, as well as the specific potential hazards related to this tool.** Following this rule will reduce the risk of electric shock, fire, or serious injury.



Always wear eye protection. Any power tool can throw foreign objects into your eyes and cause permanent eye damage. ALWAYS wear safety goggles (not glasses) that comply with ANSI safety standard Z87.1. Everyday glasses have only impact resistant lenses. They ARE NOT safety glasses.

**⚠ WARNING: Glasses or goggles not in compliance with ANSI Z87.1 could cause serious injury when they break.**

- a) **The guard provided with the tool must be securely attached to the power tool and positioned for maximum safety, so the least amount of wheel is exposed towards the operator. Position yourself and bystanders away from the plane of the rotating wheel.** *The guard helps to protect operator from broken wheel fragments and accidental contact with wheel.*
- b) **Use only bonded reinforced or diamond cut-off wheels for your power tool.** *Just because an accessory can be attached to your power tool, it does not assure safe operation.*
- c) **The rated speed of the accessory must be at least equal to the maximum speed marked on the power tool.** *Accessories running faster than their rated speed can break and fly apart.*
- d) **Wheels must be used only for recommended applications. For example: do not grind with the side of cut-off wheel.** *Abrasive cut-off wheels are intended for peripheral grinding, side forces applied to these wheels may cause them to shatter.*
- e) **Always use undamaged wheel flanges that are of correct diameter for your selected wheel.** *Proper disc flanges support the disc thus reducing the possibility of wheel breakage.*
- f) **Do not use worn down reinforced wheels from larger power tools.** *Wheels intended for a larger power tool are not suitable for the higher speed of a smaller tool and may burst.*
- g) **The outside diameter and the thickness of your accessory must be within the capacity rating of your power tool.** *Incorrectly sized accessories cannot be adequately guarded or controlled.*
- h) **The arbour size of wheels and flanges must properly fit the spindle of the power tool.** *Wheels and flanges with arbour holes that do not match the mounting hardware of the power tool will run out of balance, vibrate excessively and may cause loss of control.*
- i) **Do not use damaged wheels. Before each use, inspect the wheels for chips and cracks. If power tool or wheel is dropped, inspect for damage or install an undamaged wheel. After inspecting and installing the wheel, position yourself and bystanders away from the plane of the rotating wheel and run the power tool at maximum no load speed for one minute.** *Damaged wheel will normally break apart during this test time.*

- j) Wear personal protective equipment. Depending on application, use face shield, safety goggles or safety glasses. As appropriate, wear dust mask, hearing protectors, gloves and shop apron capable of stopping small abrasive or workpiece fragments.** *The eye protection must be capable of stopping flying debris generated by various operations. The dust mask or respirator must be capable of filtering particles generated by your operation. Prolonged exposure to high intensity noise may cause hearing loss.*
- k) Keep bystanders a safe distance away from work area. Anyone entering the work area must wear personal protective equipment.** *Fragments of workpiece or of a broken wheel may fly away and cause injury beyond immediate area of operation.*
- l) Hold the power tool by insulated gripping surfaces only, when performing an operation where the cutting accessory may contact hidden wiring.** *Cutting accessory contacting a "live" wire may make exposed metal parts of the power tool "live" and could give the operator an electric shock.*
- m) Position the cord clear of the spinning accessory,** *If you lose control, the cord may be cut or snagged and your hand or arm may be pulled into the spinning wheel.*
- n) Never lay the power tool down until the accessory has come to a complete stop.** *The spinning wheel may grab the surface and pull the power tool out of your control.*
- o) Do not run the power tool while carrying it at your side.** *Accidental contact with the spinning accessory could snag your clothing, pulling the accessory into your body.*
- p) Regularly clean the power tool's air vents.** *The motor's fan can draw the dust inside the housing and excessive accumulation of powdered metal may cause electrical hazards.*
- q) Do not operate the power tool near flammable materials.** *Sparks could ignite these materials.*
- r) Do not use accessories that require liquid coolants.** *Using water or other liquid coolants may result in electrocution or shock.*

## **KICKBACK AND RELATED WARNINGS**

Kickback is a sudden reaction to a pinched or snagged rotating wheel. Pinching or snagging causes rapid stalling of the rotating wheel which in turn causes the uncontrolled power tool to be forced in the direction opposite of the wheel's rotation at the point of the binding.















For example, if an abrasive disc is snagged or pinched by the workpiece, the edge of the wheel that is entering into the pinch point can dig into the surface of the material causing the wheel to climb out or kick out. The wheel may either jump toward or away from the operator, depending on direction of the wheel's movement at the point of pinching. Abrasive wheels may also break under these conditions.

Kickback is the result of power tool misuse and/or incorrect operating procedures or conditions and can be avoided by taking proper precautions as given below.

- a) **Maintain a firm grip on the power tool and position your body and arm to allow you to resist kickback forces. Always use auxiliary handle, if provided, for maximum control over kickback or torque reaction during start-up.** *The operator can control torque reactions or kickback forces, if proper precautions are taken.*
- b) **Never place your hand near the rotating accessory.** *Accessory may kickback over your hand.*
- c) **Do not position your body in line with the rotating wheel.** *Kickback will propel the tool in direction opposite to the wheel's movement at the point of snagging.*
- d) **Use special care when working corners, sharp edges etc. Avoid bouncing and snagging the accessory.** *Corners, sharp edges or bouncing have a tendency to snag the rotating accessory and cause loss of control or kickback.*
- e) **Do not attach a saw chain, woodcarving blade, segmented diamond wheel with a peripheral gap greater than 10 mm (approx. 3/8") or toothed saw blade.** *Such blades create frequent kickback and loss of control.*
- f) **Do not "jam" the cut-off discs or apply excessive pressure. Do not attempt to make an excessive depth of cut.** *Overstressing the wheel increases the loading and susceptibility to twisting or binding of the wheel in the cut and the possibility of kickback or wheel breakage.*
- g) **When wheel is binding or when interrupting a cut for any reason, switch off the power tool and hold the power tool motionless until the wheel comes to a complete stop. Never attempt to remove the wheel from the cut while the wheel is in motion otherwise kickback may occur.** *Investigate and take corrective action to eliminate the cause of wheel binding.*
- h) **Do not restart the cutting operation in the workpiece. Let the disc reach full speed and carefully re-enter the cut.** *The wheel may bind, walk up or kickback if the power tool is restarted in the workpiece.*
- i) **Support panels or any oversized workpiece to minimize the risk of disc pinching and kickback.** *Large workpieces tend to sag under their own weight. Supports must be placed under the workpiece near the line of cut and near the edge of the workpiece on both sides of the wheel.*
- j) **Use extra caution when making a "pocket cut" into existing walls or other blind areas.** *The protruding wheel may cut gas or water pipes, electrical wiring or objects that can cause kickback.*

## SYMBOLS

**⚠ WARNING:** Some of the following symbols may appear on the cut off saw. Study these symbols and learn their meaning. Proper interpretation of these symbols will allow for more efficient and safer operation of this tool.

<b>V</b>	VOLTS		Three-phase alternating current with neutral
<b>A</b>	Amperes		Direct current
<b>Hz</b>	Hertz	<b>n<sub>0</sub></b>	No load speed
<b>W</b>	Watts		Alternating or direct current
<b>kW</b>	Kilowatts		Class II construction
<b>µF</b>	Microfarads		Splash-proof construction
<b>L</b>	Liters		Watertight construction
<b>kg</b>	Kilograms		Protective grounding at grounding terminal, Class I tools
<b>H</b>	Hours	<b>RPM</b>	Revolutions or reciprocations per minute
<b>N/cm<sup>2</sup></b>	Newtons per square centimeter	<b>∅</b>	Diameter
<b>Pa</b>	Pascals	<b>0</b>	Off position
<b>OPM</b>	Oscillations per minute		Arrow
<b>MIN</b>	Minutes		Warning symbol
<b>S</b>	Seconds		Wear your safety glasses
 or ac.	Alternating current		Wear a dust mask
 3	Three-phase alternating current		Wear hearing protection
			Read all documentation



JD5312

This symbol designates that this tool is listed with U.S. requirements by TÜV Rheinland (Shanghai) Co., Ltd. Conforms to UL 60745-1:2007 R10.24, UL 60745-2-22:2012 R5.24 Certified to CAN/CSA-C22.2 NO.60745-1-07+G11-G17, CAN/CSA-C22.2 NO.60745-2-22-12(R2022)

# KNOW YOUR 20V MAX BRUSHLESS TILE AND CUT OFF SAW

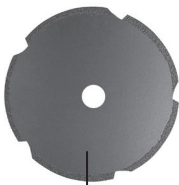
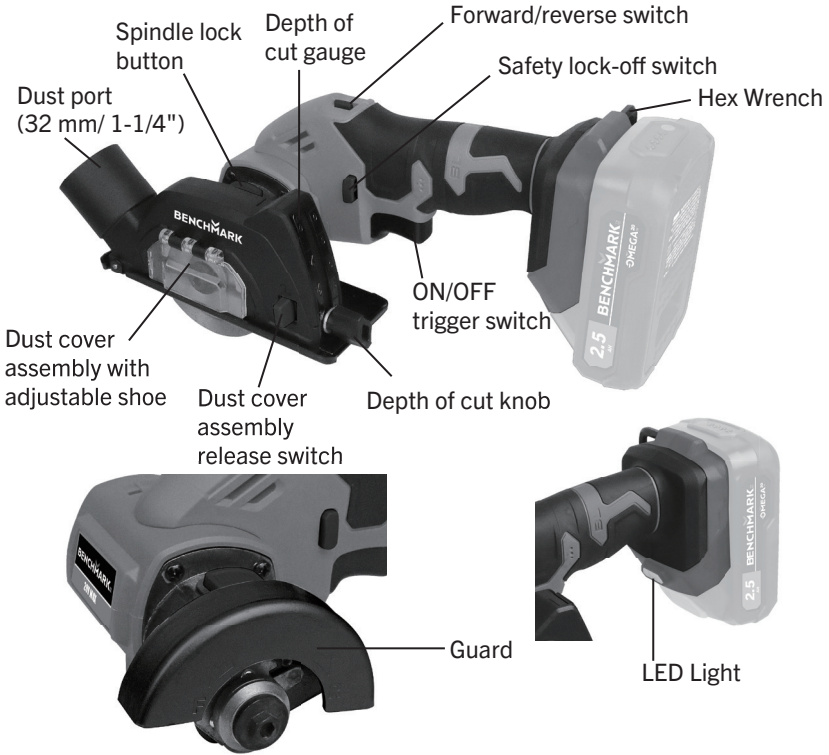

Diamond multi-material cutting disc



Bonded abrasive cutting disc



Diamond tile cutting disc

## ASSEMBLY AND OPERATION

### INSTALLING CUTTING DISCS

**⚠ WARNING:** To minimize the risk of eye injury, always use eye protection. Foreign objects in the workpiece such as wire or nails can cause tips to crack or break. Always mount the disc securely, in the proper direction of rotation, before use, and ensure it is clean and sharp.

**⚠ WARNING:** To reduce the risk of injury, only use discs that are no greater than 76 mm (3") in diameter, have an inner diameter of 10 mm (approx. 3/8"), and without cutting teeth. Thickness of disc not to exceed 2.3 mm (0.09").

A dull disc will cause slow inefficient cutting, overload the motor, could cause excessive splintering, and could increase the possibility of kickback. Please refer to the table below to determine the correct disc for your application.

Disc type	Application
Diamond multi-material cutting disc	Drywall, fiber cement, plastic, steel, non ferrous materials
Bonded abrasive cutting disc	Steel, stainless steel, ferrous materials
Diamond Tile cutting disc	Ceramic tile, porcelain and granite/marble/stone and clay.

1. Remove the battery and dust cover assembly (see installing/removing the Dust Cover Assembly with Adjustable Shoe).
2. Place tool on a firm surface with guard facing up.
3. Insert the hex key (1) into the hex head screw (2) (Fig. 1).
4. Depress the spindle lock button (3), turn the hex screw clockwise to remove both the hex head screw and the flange washer (4) (Fig. 1).
5. Slide the cutting disc (5) into the guard (6) and place it over the spindle shoulder (7) so it rests flat against the large spindle flange (8) (Fig. 1).
6. Reinstall and tighten the flange washer and hex screw.

**NOTE:** Make sure the cutting disc is on the spindle shoulder before tightening the hex head screw.

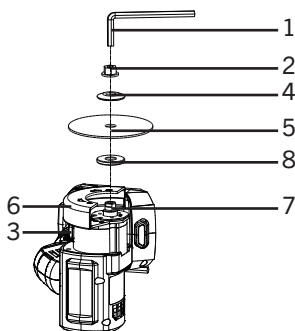

**FIG. 1**

## ADJUSTING THE GUARD

**⚠️ WARNING:** Moving the guard backward increases the exposed area of the disc, which can raise the risk of kickback. Only reposition the guard to allow greater disc exposure when absolutely necessary for the task. The guard angle can be adjusted to suit different cutting applications.

To adjust the guard:

1. Remove the battery to ensure the tool is powered off.
2. Firmly grasp the guard and rotate it to the desired angle.

**NOTE:** The guard can rotate up to 30° forward or backward (see Fig. 2).

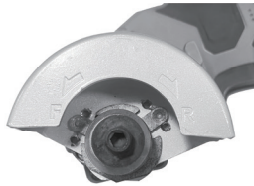

FIG. 2

## INSTALLING THE DUST COVER WITH ADJUSTABLE SHOE ASSEMBLY

**NOTE:** The dust cover is only for tile/concrete and drywall cutting applications to connect to a vacuum for dust collecting. We do not recommend use of the dust cover assembly for metal cutting applications.

1. Remove the battery.
2. With the cutting disc (2) properly installed, rotate the guard (5) all the way forward.
3. Loosen the depth of cut knob (1) and pull the shoe (6) down to its lowest setting (Fig.3).
4. Maneuver the guard and cutting disc (2) into the dust cover assembly (3) and rotate tool to lock in place. The front of the guard will rest against the stop inside the assembly, and the back of the guard will catch the dust cover assembly quick release switch. (4) (Fig. 3).
5. Push the dust cover assembly quick release switch to the "locked" position.

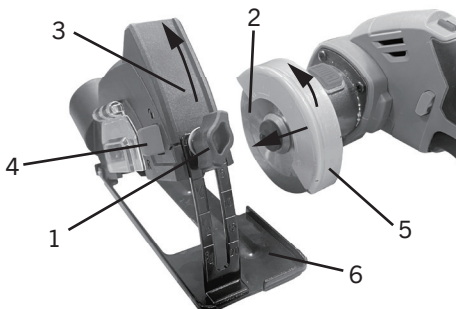

FIG. 3

## REMOVING THE DUST COVER WITH ADJUSTABLE SHOE ASSEMBLY

1. Remove the battery.
2. Loosen the depth of cut knob (1) and pull the shoe (6) down to its lowest setting (Fig.3).
3. Push the dust cover assembly quick release switch to the "unlocked" position and rotate the tool out of the dust cover assembly (3) (Fig. 3).

## ADJUSTING THE DEPTH OF CUT

**NOTE:** The depth of cut cannot be adjusted or set unless the dust cover assembly with adjustable shoe is installed.

Loosen the depth of cut knob (1) and slide the shoe (2) on the dust cover assembly up or down. Use the markings on the depth of cut gauge (3) to help determine proper depth. Adjust the cutting depth to the thickness of the workpiece. Less than 1/4" of the disc should be visible below the workpiece (Fig. 4).



**FIG. 4**

## ON/OFF TRIGGER SWITCH / SAFETY LOCK-OFF

For safety, the tool is equipped with a lock-off switch (1) that helps prevent accidental starting. This safety switch must be pressed before the ON/OFF trigger switch (2) can be activated. The tool will only start/run when both the lock-off switch and trigger switch are properly engaged (FIG.5).



**FIG. 5**

### FORWARD/REVERSE

The cut-off tool is equipped with a forward/reverse. Some applications or accessories may require the tool to be run in forward or reverse. When making a cut, select the direction of cut that allows the tool to be pushed away from your body. When installing a diamond disc, select the rotation that matches the arrow on the disc.

For forward rotation, push the forward/reverse button all the way to the left (1) (Fig. 6).

For reverse rotation, push the forward/reverse button all the way to the right (2) (Fig. 6).

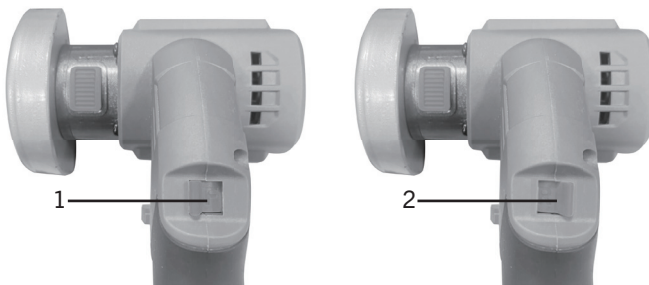

FIG. 6

### LED LIGHT

This tool is equipped with an LED work light located on the foot of the tool. The LED activates automatically when the trigger switch is pulled and remains on for the duration of tool operation, providing improved visibility in low-light conditions. Once the trigger is released and the tool powers down, the LED will remain on for approximately 5 seconds before automatically turning off.

### VACUUM HOSE INSTALLATION

The vacuum hose connects to the dust port located on the removable dust cover assembly. If the dust cover is not already installed on the tool, attach it before connecting the vacuum hose. Using a vacuum system helps minimize dust in the work area during cutting.

1. Ensure the dust cover assembly (4) is properly installed on the tool (refer to the section Installing the dust cover assembly if needed).
2. Push the small vacuum connector (1) on the end of the vacuum hose (2) onto the dust port (3) located on the front-left side of the dust cover assembly (4) (Fig. 7).
3. Twist and push the vacuum connector to lock it securely in place.
4. Connect the other end of the hose to your workshop vacuum.

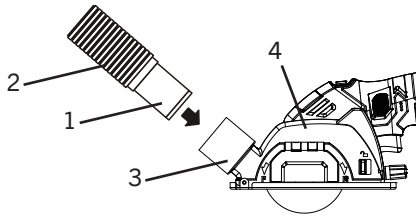

**FIG. 7**

**⚠ WARNING:** Do Not use dust extraction when cutting metal. Metal cutting can produce hot debris and sparks that may melt vacuum hoses or ignite a fire inside the vacuum. Always disconnect the vacuum system when performing metal cutting operations.

## **GENERAL CUTTING**

**⚠ WARNING:** Always wear ANSI-approved eye protection. When cutting tile, masonry, or other dust-producing materials, also wear a NIOSH-approved respirator. Hearing protection and gloves are recommended.

1. Remove the battery pack before making any adjustments or changing accessories.
2. Depth Adjustment:
  - a) With dust cover assembly and adjustable shoe installed: Cutting depth can be adjusted by setting the shoe position. Ensure the assembly is properly installed before adjusting.
  - b) Without dust cover assembly: Depth adjustment is not possible. The saw will operate at its fixed cutting depth. Never attempt to bypass this mechanism.
3. Reinstall the battery pack after adjustments are complete.
4. Cutting Technique:
  - a) With dust cover assembly and shoe installed: Keep the shoe flat against the work surface and maintain a firm grip.
  - b) Without dust cover assembly: Hold the saw securely with both hands and maintain a stable stance. Extra care is needed as the tool lacks the guiding shoe and stability provided by the assembly.
  - c) Do not force the tool through the material — allow the saw to cut at its own pace to avoid kickback.
  - d) When making partial cuts, restarting a cut, or correcting cut direction, allow the cutting disc to stop completely. Center the disc in the kerf, pull the saw back slightly, squeeze the trigger, and re-enter the cut slowly.
5. Stopping the Tool: Release the trigger switch to stop the saw.

**GENERAL CUTTING**

Additional Tips:

- Ensure the material is securely clamped before cutting.
- Avoid cutting wet materials .
- Periodically check the cutting disc for wear or damage — replace if necessary.
- Allow the tool to reach full speed before entering the cut for smoother operation.

## MAINTENANCE

**⚠ WARNING:** To reduce the risk of injury, always unplug the charger and remove the battery pack from the charger or tool before performing any maintenance. Never disassemble the tool, battery pack or charger.

**⚠ WARNING:** When servicing, use only identical replacement parts. The use of any other part may create a hazard or cause product damage.

DO NOT use solvents when cleaning plastic parts. Plastics are susceptible to damage from various types of commercial solvents and may be damaged by their use. Use a clean cloth to remove dirt, dust, oil, grease etc.

**⚠ WARNING:** DO NOT allow brake fluids, gasoline, petroleum-based products, penetrating oils, etc. to come into contact with plastic parts. They contain chemicals that can damage, weaken, or destroy plastic.

DO NOT abuse power tools. Abusive practices can damage the tool and the workpiece.

**⚠ WARNING:** DO NOT attempt to modify tools or create accessories. Any such alteration or modification is misuse and could result in a hazardous condition leading to possible serious injury. It will also void the warranty.

**⚠ WARNING:** Always wear safety goggles or safety glasses with side shields during all cutting operations. It is critical that you also wear safety goggles or safety glasses with side shields and a dust mask while blowing dust out of the tool with an air jet. Failure to take these safety precautions could result in permanent eye or lung damage.

## CLEANING

**⚠ WARNING:** Blow dirt and dust out of the main housing with dry air as often as dirt is seen collecting in and around the air vents. Wear approved eye protection and approved dust mask when performing this procedure.

**⚠ WARNING:** Never use solvents or other harsh chemicals for cleaning the non-metallic parts of the tool. These chemicals may weaken the materials used in these parts. Use a cloth dampened only with water and mild soap. Never let any liquid get inside the tool; never immerse any part of the tool into a liquid.

**EXPLODED VIEW**

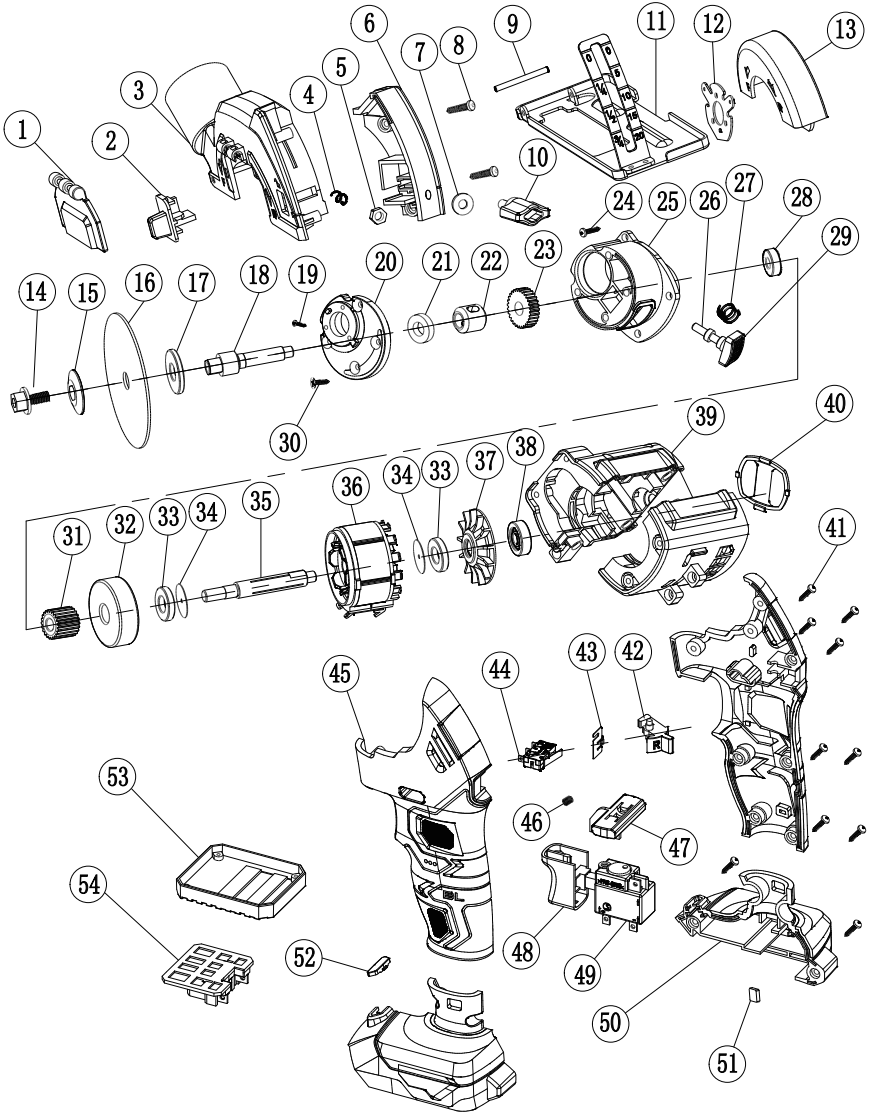

## PARTS LIST

**⚠ WARNING:** When servicing, use only original equipment replacement parts. The use of any other parts may create a safety hazard or cause damage to the tool.

Any attempt to repair or replace electrical parts on this tool may create a safety hazard unless repairs are performed by a qualified technician. For more information, call the Toll-free Helpline, at 1-866-349-8665; Monday - Friday: 9am to 5pm EST.

Always order by part number.

Key #	Part #	Part Name	Quantity
1	3180010023	Dust cover	1
2	3120020177	Quick adjustment knob	1
3	3160040136	Fixed protective cover	1
4	2050060311	Spring	1
5	4060010026	Hex nut	1
6	3160040137	Fixed protective cover upper cover	1
7	2030020443	Shim	1
8	4030010099	Screw ST3 x 14	2
9	2040160241	Plug	1
10	1180050057	Depth of cut knob	1
11	2030040078	Baseplate	1
12	2030160175	Elastic pressure plate	1
13	2030130048	Dust cover	1
14	4020080019	Hex nut	1
15	2010140063	External pressure plate	1
16	6070040131	Cutting disc	1
17	2010140062	Internal pressure plate	1
18	2040050222	Main shaft	1
19	4020010221	Screw 3 x 14	3
20	2020010051	Gearbox cover	1
21	4010010041	Bearing 688-2Z	1
22	2040310088	Shaft sleeve lock	1
23	2040070025	Bull gear	1
24	4030010288	Screw ST4 x 16	4
25	2020010050	Gearbox	1
26	2030250024	Spindle lock rod	1
27	2050060220	Spring	1
28	4010010042	Bearing 696-2Z	1
29	1180050058	Spindle lock rod button	1

Key #	Part #	Part Name	Quantity
30	4020020014	Screw M3 x 14	1
31	2040070026	Motor gear	1
32	4010010106	Bearing 627-2RS	1
33	2010130068	Balance weight	2
34	2050050062	Shim	2
35	2040020015	Rotor shaft	1
36	1030300035	Motor assembly	1
37	3150010150	Wind blade	1
38	4010010031	Bearing 626-2Z	1
39	3150190235	Motor cylinder	1
40	3160010090	Rear cover of motor	1
41	4030010099	Screw ST3 x 14	13
42	3120020178	Forward/reverse rotation knob	1
43	2030100102	Button spring clip	1
44	1062010047	Small switch	1
45	3010070032	Shell	1
46	2050060218	Spring	1
47	3120040086	Switch lock rod	1
48	3120010101	Switch button	1
49	1060190009	Switch	1
50	3010070033	Foot plate	1
51	2010170042	Magnetic block	1
52	3160060120	LED Light cover	1
53	2020090009	Aluminum shell of circuit board	1
54	3150170027	Electrode plate 5095	1

## **WARRANTY**

### **BENCHMARK WARRANTY FOR 20V MAX BRUSHLESS TILE AND CUT OFF SAW**

If this Benchmark tool fails due to a defect in material or workmanship within five years from the date of purchase, return it to any Home Hardware store with the original bill of sale for exchange. This warranty does not include expendable parts including but not limited to blades, brushes, belts, light bulbs.

This warranty covers defects in material or workmanship only. It does not cover normal wear and tear, failure due to abuse/misuse, or defects caused by careless or accidental mishandling. If this Benchmark product is used for commercial or rental purposes, this warranty does not apply.

# 20V MAX<sup>†</sup> BRUSHLESS TILE AND CUT-OFF SAW



**BENCHMARK**<sup>TM</sup>  
MC

**BENCHMARK TOOLS CANADA**  
ST. JACOBS, ONTARIO N0B 2N0  
© 2026 Home Hardware Stores Limited

**CUSTOMER SERVICE/TECH SUPPORT**  
1-866-349-8665

**3646-007**

Made in China



\*This Benchmark<sup>TM</sup> product carries a five (5) year LIMITED warranty against defects in workmanship and materials.



c U.S.

JD5312

**READ ALL INSTRUCTIONS BEFORE FIRST USE.  
KEEP THIS MANUAL FOR FUTURE REFERENCE.  
KEEP AWAY FROM CHILDREN.**



**WEAR CSA APPROVED  
EYE PROTECTION**



**WEAR EAR  
PROTECTION**



**WEAR A  
FACE MASK**