

SPECIFICATIONS:

- Vitreous china
- High efficiency
- 4.8Lpf / 1.28Gpf
- 16½" Plus Height elongated bowl
- Siphon jet flush action
- Concealed skirted trapway
- Chrome side tank lever
- 12" (305mm) rough-in
- 2" fully glazed trapway
- Smooth close plastic toilet seat included
- 100% factory flush tested

OVERALL DIMENSIONS:

16⅞" (W) x 28⅜" (D) x 29⅞" (H)
 430mm (W) x 720mm (D) x 740mm (H)

SHIPPING:

Cube 8.99
GW 122 lbs

COMPLIANCE CERTIFICATIONS:

Meets or exceeds the following specs:

- IAPMO cUPC
- ASME A112.19.2 / CSA B45.1
- US EPA WaterSense Specification
- ADA Guidelines & ANSI A117.1
- CSA B651 and OBC barrier free
- MaP tested 1000g



ITEM TO BE SPECIFIED:

SOFT WHITE:

TL-6289HC-EWL (Lined Tank)

UPC: 721015434825

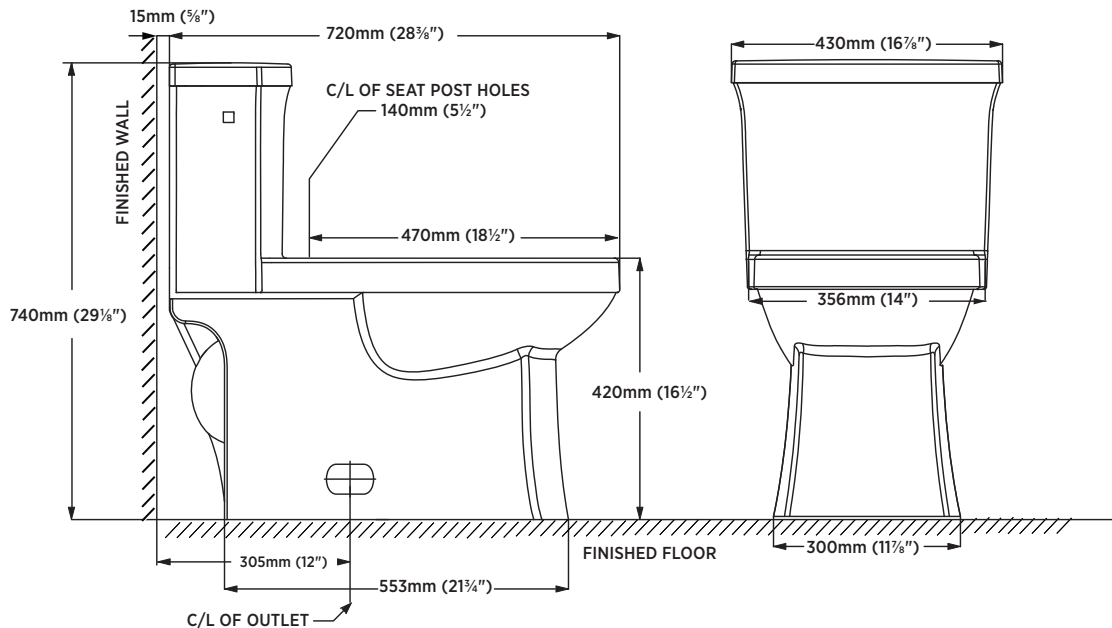

Notes:

Important: Dimensions of product are nominal and may vary within the range of tolerances allowed. These measurements are subject to change or cancellation. No responsibility is assumed for use of superseded or voided pages.