



**MUSTEE**  
Preferred by the "Pros"

# 12 UTILATUB® Floor Mount Laundry/Utility Tubs — Economy — Extra Narrow

**SEE PAGE 2 FOR A LIST OF ACCESSORIES!**



## Design features:

- One piece molded construction, using Mustee's Co-Polypure™ resin
- Extra narrow – just 18" wide – fits where other tubs can't
- 15 Gallon capacity, extra deep 13" tub with smooth surface
- Leakproof, integrally molded-in drain with stopper
- Connects to standard 1½" P or S trap
- Accommodates dual-handle faucet with 4" center
- Includes finished steel legs with adjustable levelers
- Mold and mildew-resistant components
- Easy to assemble and install
- Color-fast white finish

## Specifications

Colors & Models:	Model	Mounting	H x W x D	UPC
White	12	Floor	33" x 18" x 23-1/2"	6 71031 00007 1

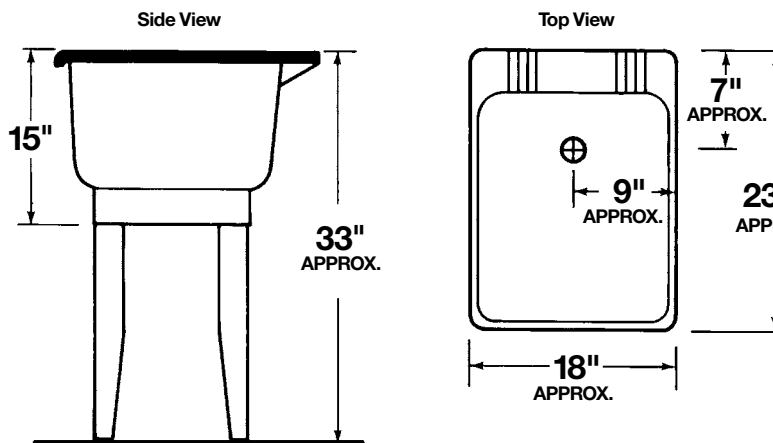

**General:** Furnish and install as shown on plans, UTILATUB® Laundry/Utility Tub model 12, as manufactured by E.L. Mustee & Sons, Inc. Tub shall be one-piece molded construction using Co-Polypure™ resin with matched metal molds under extreme heat and pressure. Tub to be 18" wide and include integrally molded drain assembly for connection to standard 1-1/2" P or S-trap, stopper and finished steel legs with built-in levelers. 15 gallon capacity tub, 13" deep. Shall meet ANSI Z 124-2011. Color: White. Weight: 15 lbs.



**MUSTEE**

E.L. Mustee & Sons, Inc. • 5431 West 164th Street • Brook Park, OH 44142 • Phone: 216.267.3100 • Fax: 216.267.9997  
E-mail: info@mustee.com. • Web: www.mustee.com • Proudly made in the USA

Notice: Our continuous commitment to product improvement may result in changes to product specifications without notice. Patents pending. Made and Printed in U.S.A.