



KINDRED

GRANITE WORKSTATION SINK

DOUBLE BOWL 31" DUALMOUNT

MODEL: 72209310ONKIT (ONYX)

- ✓ Made from high quality quartz and acrylic resin that makes the sink stain and scratch resistant
- ✓ UV Protection ensures that the color does not fade over time and retains its beauty
- ✓ Strong enough to withstand hot pans straight from the oven due to heat and thermal shock resistance
- ✓ Easy to clean Dura- Kleen finish repels stains like wine, coffee and grease. Cleans easily with soapy water.

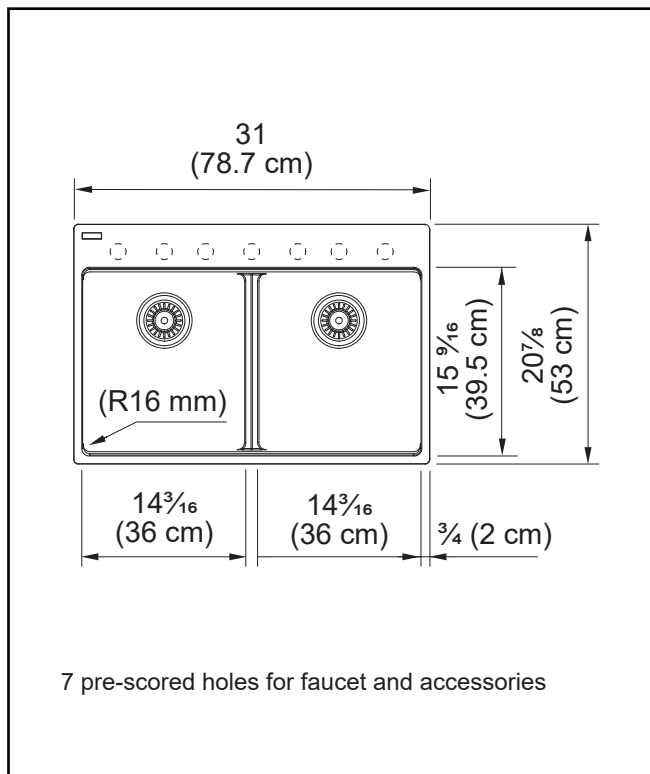

TECHNICAL FEATURES

OVERALL SINK SIZE (OD)	20 7/8" FB x 31" LR
EQUAL BOWL SIZE (ID)	14 3/16" FB x 15 9/16" LR
BOWL DEPTH (ID)	9 1/2" DP
MINIMUM CABINET SIZE	33"
CORNER RADIUS	16 mm
DRAIN HOLE LOCATION	Rear
INSTALLATION TYPE	Dualmount
SOUND DAMPENING	Natural Sound Absorbing
WEIGHT	48 lbs
WARRANTY	Limited Lifetime
COUNTRY OF ORIGIN	Slovakia

INCLUDED ACCESSORIES

STRAINER BASKET	1135 (2)
CUTTING BOARD	112.0737.087
COLANDER	112.0737.088
ROLLER MAT	112.0737.090



KINDRED

ÉVIER POSTE DE TRAVAIL DE CUISINE

ÉVIER À DEUX CUVES SOUS PLAN/EN SURFACE

MODÈLE: 72209310ONKIT (ONYX)

- ✓ La fabrication en quartz et résine acrylique de haute qualité faisant de l'évier un produit incroyablement robuste.
- ✓ La protection UV garantit que ces magnifiques produits conserveront leurs tons naturels durant des années.
- ✓ Suffisamment solide pour supporter des faitouts chauds tout droit sortis du four.
- ✓ Le fini lisse du granite repousse les taches, notamment de vin, de café et de graisse. Se nettoie facilement à l'eau savonneuse.

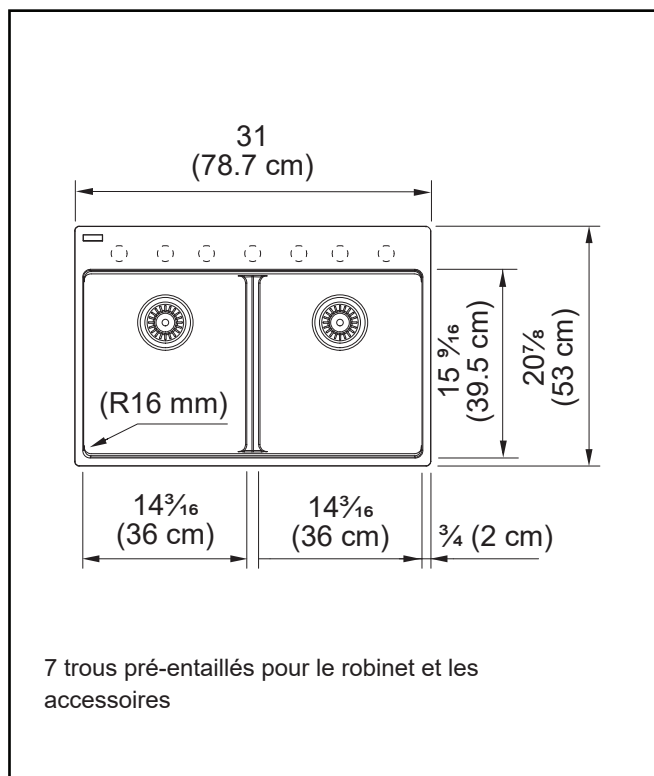

CARACTÉRISTIQUES TECHNIQUES

DIMENSIONS EXTÉRIEURES	20 7/8" AA x 31" GD
DIMENSIONS DES CUVETTES	14 3/16" AA x 15 9/16" GD
PROFONDEUR DES CUVETTE	9 1/2"
DIMENSION MIN. D'ARMOIRE	33"
RAYON DE COIN	16 mm
EMPLACEMENT DE L'ORIFICE D'ÉVACUATION	Arrière
INSTALLATION	Sous plan / en surface
POIDS	48 lbs
GARANTIE	Vie limitée
PAYS D'ORIGINE	Slovakia

ACCESSOIRES COMPRIS

CRÉPINE-PANIER	1135 (2)
PLANCHE À DÉCOUPER	112.0737.087
PASSOIRE	112.0737.088
GRILLE ENROULABLE	112.0737.090