

# BENCHMARK™

## 20 GAL (75.7) L AIR COMPRESSOR



3 Year Limited Warranty



**READ ALL INSTRUCTIONS BEFORE FIRST USE.  
KEEP THIS MANUAL FOR FUTURE REFERENCE.  
KEEP AWAY FROM CHILDREN.**



**WEAR CSA APPROVED  
EYE PROTECTION**



**WEAR EAR  
PROTECTION**



**WEAR A  
FACE MASK**

## PRODUCT SPECIFICATIONS

20 GAL AIR COMPRESSOR	
Model No	1635-712
Pump	Oil free, Direct drive
Motor	1.8 HP†
Voltage/Amps/Hz	120/12/60
Air Tank Capacity	20 Gallon (75.7 L)
Maximum Pressure	150 PSI†
CFM @ 40 PSI	5.5*
CFM @ 90 PSI	4.5*
Power Cord	SJT16AWG x 6 ft

### NEED ASSISTANCE?

Call us on our toll-free customer support line:

1-866-349-8665 (Monday through Friday 9am - 5pm Eastern Standard Time)

- Technical questions
- Replacement parts
- Parts missing from package

\* CFM: Cubic Feet per Minute.

† This compressor is rated in accordance with ISO 1217, displacement compressors acceptance tests.

**TABLE OF CONTENTS**

Product Specifications ..... 1

Table Of Contents ..... 2

General Safety Warnings ..... 3

Safety Symbols ..... 3

Specific Safety Instructions For 20 Gal Air Compressor ..... 3

Safety Instructions ..... 4

Overview .....7

Tool Compatibility Chart ..... 8

Important Information ..... 9

Assembly ..... 10

Operating Instructions ..... 11

Maintenance ..... 14

Troubleshooting ..... 16

Exploded View ..... 19

Parts List ..... 20

Warranty ..... 22





## GENERAL SAFETY WARNINGS

### IMPORTANT SAFETY INSTRUCTIONS

Read and understand all safety and operational instructions. Failure to follow the safety rules listed below and other basic safety precautions may result in serious personal injury. Keep this manual, sales receipts and applicable warranty forms for future reference.

### SAFETY SYMBOLS

The purpose of safety symbols is to alert you of the potential safety RISKS. Recognize and understand them. Follow the instructions provided.

SYMBOL	MEANING
 <b>DANGER</b>	Failure to obey a <b>DANGER</b> safety alert <b>WILL</b> result in serious personal injury or death to you or to others. Always obey all messages following this symbol to reduce the risk of serious personal injury or death.
 <b>WARNING</b>	Failure to obey a <b>WARNING</b> safety alert <b>MAY</b> result in serious personal injury or death to you or to others. Always obey all messages following this symbol to reduce the risk of potential serious personal injury or death.
 <b>CAUTION</b>	Failure to obey a <b>CAUTION</b> safety alert <b>MAY</b> result in personal injury or property damage to you or to others. Always obey all messages following this symbol to reduce the risk of personal injury or property damage.
<b>NOTICE</b>  <b>CAUTION</b>	Failure to obey a <b>NOTICE</b> or a <b>CAUTION</b> (without a safety alert) <b>MAY</b> result in property damage to you or to others. Always obey all messages following this symbol to reduce the risk of property damage.

## SPECIFIC SAFETY INSTRUCTIONS FOR 20GAL AIR COMPRESSOR

### SAVE THIS MANUAL FOR FUTURE REFERENCE

- The purpose of safety symbols is to attract your attention to possible dangers. The safety symbols, and the explanations with them, deserve your careful attention and understanding. The symbol warnings do not by themselves eliminate any danger. The instructions and warnings they give are no substitutes for proper accident prevention measures.
- Be sure to read and understand all safety instructions in this manual, including all safety alert symbols such as “DANGER”, “WARNING” and “CAUTION”, before using this power tool. Failure to follow all instructions listed below may result in electric shock, fire and/or serious personal injury.

## **SAFETY INSTRUCTIONS**

### **WORK AREA SAFETY**

- Keep your work area clean and well lit. Cluttered workbenches and dark areas invite accidents.
- Do not operate power tools in explosive atmospheres, such as in the presence of flammable liquids, gases, or dust. Power tools create sparks which may ignite the dust or fumes.
- Keep bystanders, children and visitors away while operating a power tool. Distractions can cause you to lose control.
- Make your workshop childproof with padlocks and master switches. Lock tools away when not in use.
- Make sure the work area has ample lighting so you can see the work and that there are no obstructions that will interfere with safe operation before using your power tool.

### **PERSONAL SAFETY**

- 1. Know your power tool. Read the operator's manual carefully. Learn the power tools applications and limitations, as well as the specific potential hazards related to this tool.
- Stay alert, watch what you are doing and use common sense when operating a power tool.
- Do not use tool while tired or under the influence of drugs, alcohol or medication. A moment of inattention while operating power tools may result in serious personal injury.
- Dress properly. Do not wear loose clothing or jewelry. Pull back long hair. Keep your hair, clothing, and gloves away from moving parts. Air vents often cover moving parts and should also be avoided. Loose clothing, jewelry or long hair can be caught in moving parts.
- Avoid accidental starting. Be sure switch is in "OFF" position before plugging in. Do not carry tools with your finger on the switch. Carrying tools with your finger on the switch or plugging in tools that have the switch in the "ON" position invites accidents.
- Remove adjusting keys or wrenches before turning the tool "ON". A wrench that is left attached to a rotating part of the tool may result in personal injury.
- Do no overreach. Keep proper footing and balance at all times. Proper footing and balance enables better control of the tool in unexpected situations.
- Always secure your work. Use clamps or a vise to hold work when practical. It is safer than using your hand and frees both hands to operate tool.
- Use safety equipment. Always wear eye protection. Dust mask, non-skid safety shoes, hard hat or hearing protection must be used for appropriate conditions.
- Do not use on a ladder or unstable support. Stable footing on a solid surface enables better control of the tool in unexpected situations.

## TOOL USE AND CARE SAFETY

### WARNING

Be sure to read and understand all instruction before operating this power tool. Failure to follow all instructions listed below may result in electric shock, fire and/or serious Personal injury.

- Always use clamps or other practical ways to secure and support the work piece to a stable platform. Holding the work by hand or against your body is unstable and may lead to loss of control.
- Do not force the tool. Use the correct tool and blade for your application. The correct tool and blade will do the job better and safer at the rate for which it is designed.
- Do not use the tool if switch does not turn it “ON” or “OFF”. Any tool that cannot be controlled with the switch is dangerous and must be repaired
- Disconnect the plug from the power source before making any adjustments, changing accessories or storing the tool. Such preventive safety measures reduce the risk of starting the tool accidentally.
- Never leave the tool running. Always turn it off. Do not leave the tool until it comes to a complete stop.
- Store idle tools out of the reach of children and other untrained persons. Tools are dangerous in the hands of untrained users.
- Maintain tools with care. Keep cutting tools sharp and clean. Properly maintained tools with sharp cutting edges are less likely to bind and are easier to control.
- Check for misalignment or binding of moving parts, breakage of parts, and any other condition that may affect the tool’s operation. If damaged, have the tool serviced before using. Many accidents are caused by poorly maintained tools.
- Use only accessories that are recommended for this tool. Accessories that may be suitable for one tool may become hazardous when used on another tool.

### ELECTRICAL SAFETY

- Avoid body contact with grounded surfaces such as pipes, radiators, ranges, and refrigerators. There is an increased risk of electric shock if your body is grounded.
- Do not expose power tools to rain or wet conditions. Water entering a power tool will increase the risk of electric shock.
- Do not abuse the cord. Never use the cord to carry the tool or pull the plug from an outlet. Keep the cord away from heat, oil, sharp edges, and moving parts.
- Replace damaged cords immediately. Damaged cords increase the risk of electric shock.

**NOTE**

This compressor should be used on a nominal 120V grounded circuit. Use a power cord that is equipped with a grounding plug. Verify that the compressor is plugged into an outlet that has the same configuration as the plug. Do not use an adaptor with this compressor.

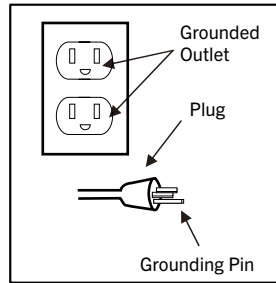

**EXTENSION CORDS**

**⚠️ CAUTION**

Keep the extension cord clear of the working area. Position the cord so that it will not get caught on lumber, tools or other obstructions while you are working with a power tool.

**⚠️ WARNING**

Check extension cords before each use. If damaged replace immediately. Never use tool with a damaged cord since toughing the damaged area could cause electrical shock, resulting in serious injury.

Use a proper extension cord. Only use cords listed by Underwriters Laboratories (UL). Other extension cords can cause a drop in line voltage, resulting in a loss of power and overheating of tool. When operating a power tool outdoors, use an outdoor extension cord marked “W-A” or “W”. These cords are rated for outdoor use and reduce the risk of electric shock.

<b>MINIMUM GAUGE FOR EXTENSION CORDS</b>					
(When using 120 volts only)					
<b>Ampere Rating</b>		<b>Total Length Of Cord</b>			
More Than <	>Less Than	25ft.	50ft.	100ft.	150ft.
0	6	18	16	16	14
6	10	18	16	14	12
10	12	16	16	14	12
12	16	14	12	Not Recommended	

## OVERVIEW

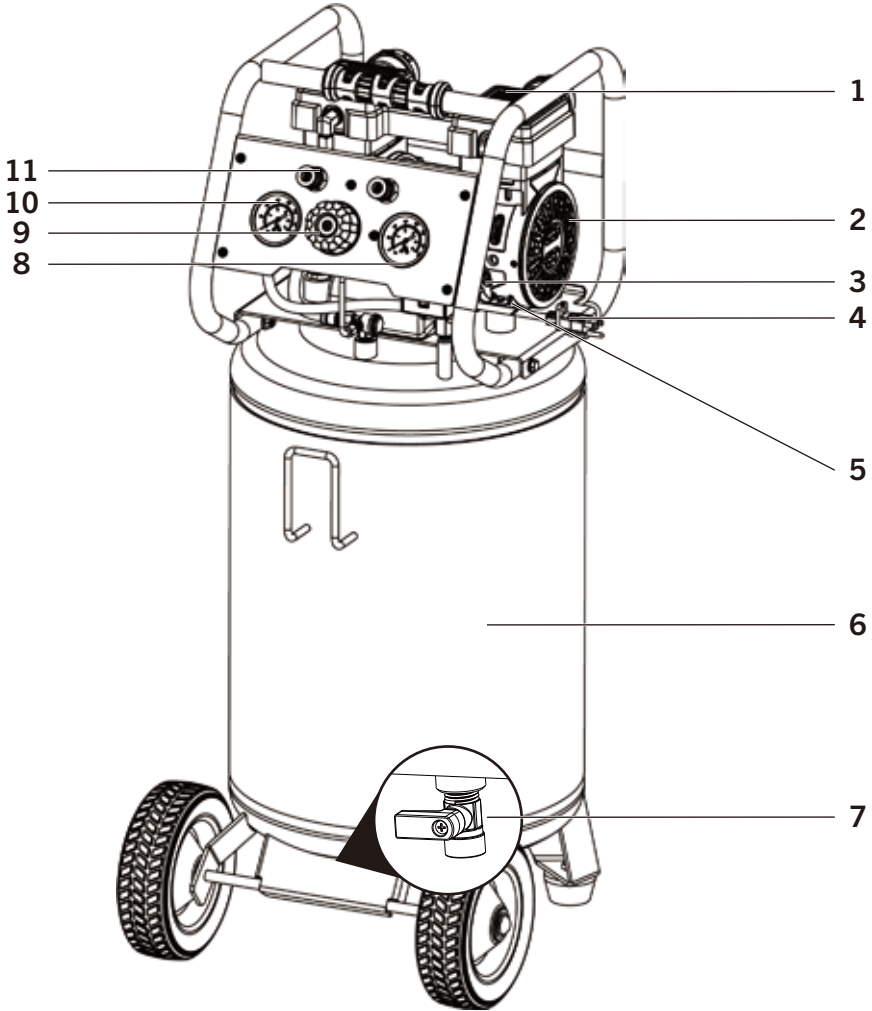

- 1. Air Compressor Pump
- 2. Electrical Motor
- 3. ON/OFF Switch
- 4. Power Cord
- 5. Safety Valve
- 6. Air Tank

- 7. Drain Valve
- 8. Outlet Pressure Gauge
- 9. Air Pressure Regulator
- 10. Tank Pressure Gauge
- 11. Quick Coupler

## TOOL COMPATIBILITY CHART

RECOMMENDED TOOL USAGE			
Inflation/Cleaning	✓	Brad Nailer/Staplers	✓
Finishing Nailer	✓	Roofing Nailer	✓
Framing Nailer	✓	Grease/Caulking Guns	✓
Flooring Nailer	✓	Impact Wrenches	✓
Drills, Hammer/Chisels	✓	Angle Grinder	✓
Cut-off Tool/Herramienta	!	Sander/Lijadora	!
Diy Paint Sprayers	!		

✓ Recommended Use

! Intermittent Use

X Not Recommended

### IMPORTANT INFORMATION

This air compressor is ideal for a wide range of jobsite applications. The 20 gallon design provides optimum pressure. It features a 1.8 HP universal motor and oil-free pump. The procedures described in this manual are solely for this 20 gallon air compressor at a maximum pressure of 150 PSI.

#### Compatible compressor and air tool - proper usage and operation

Always ensure the use of appropriately matched air tools with your Air Compressor. Be sure that the air compressor being used can supply the appropriate volume, pressure and delivery rate of air to the tool(s) without running continuously. Using tools or combinations of tools that, together or separately, require more than the air compressor can deliver will void the air compressor guarantee/warranty.

## PRODUCT FEATURES

### **Electric Motor**

The motor is used to power the pump. It is equipped with a thermal overload protector. If the motor overheats for any reason, the thermal overload protector will shut it down in order to prevent the motor from being damaged.

### **Air Compressor Pump**

The pump compresses the air and discharges it into the tank via the piston that moves up and down in the cylinder.

### **Safety Valve**

This valve is used to prevent the compressor from building too much pressure. If the pressure reaches the preset level of the motor, it will automatically pop open. You can also pull the ring on the valve to open manually.

### **ON/OFF Switch**

This switch turns on the compressor and is operated manually. When in the ON position, it allows the compressor to start up or shut down automatically, without warning, upon air demand. ALWAYS set this switch to OFF when the compressor is not being used and before unplugging the compressor.

### **Air Pressure Regulator**

The regulator is used to adjust the pressure inside the line to the tool that is being used. Turn the knob clockwise to increase the pressure and counter-clockwise to decrease the pressure.

### **Tank Pressure Gauge**

The gauge measures the pressure level of the air that is stored in the tank. It cannot be adjusted by the operator and it does not indicate the pressure inside the line.

### **Quick Coupler**

The gauge measures the regulated outlet pressure.

### **Air Tank Drain Valve**

The drain valve is used to remove moisture from the air tank after the compressor is shut off.

### **Air Tank**

The tank is where the compressed air is stored.



### **Power Cord**

This product is for use on a nominal 120-volt circuit and should be grounded. A cord with a grounding plug as illustrated must be used. Make sure that the product is connected to an outlet that has the same configuration as the plug. No adapter should be used with this product. Check with a licensed electrician if the grounding instructions are not understood or there is doubt as to whether the product is properly grounded. Do not modify the plug provided. If it will not fit the outlet, have the power outlet installed by a licensed electrician.

## ASSEMBLY

- Unpack the air compressor unit. Inspect the unit for damage. If the unit has been damaged, contact the retailer immediately.
- Check the air compressor's identification label to ensure that you have purchased the intended model and that it has the required pressure rating for its intended use.

### PRODUCT FEATURES

DESCRIPTION	QTY	ILLUSTRATION
Air compressor	1	
Owner's manual	1	

### POSITIONING OF THE AIR COMPRESSOR

1. Position the air compressor (1) near an electrical outlet (2)(FIG. A).
2. The compressor must be at least 12"(31cm) from any wall (3) or abstraction, in a clean, well-ventilated area to ensure sufficient air flow and cooling(FIG. A).
3. Place the air compressor on the floor or a hard, level surface.  
The air compressor must be level to ensure proper drainage of the moisture in the tank.
4. Connect the air hose (1) to the compressor's air outlet (universal coupler) (2) with the universal quick plug (3) (FIG. B).

### NOTE

Attach air hose and accessories (not provided). Apply plumber's tape on all the threads to prevent air leakage.

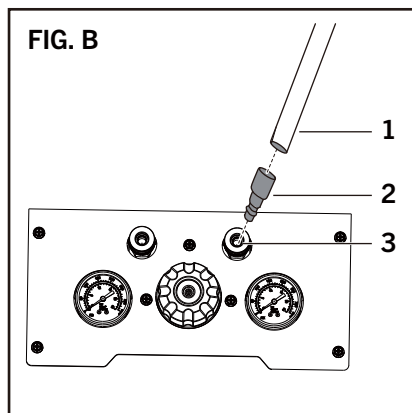
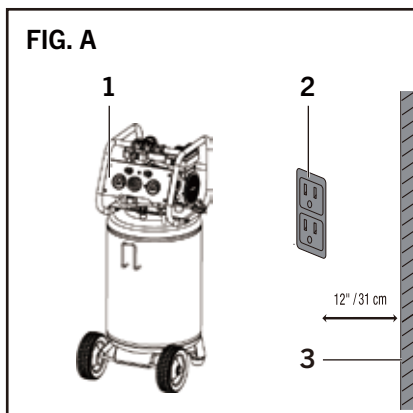

## OPERATING INSTRUCTIONS

### Break In The Pump

1. Set the ON/OFF switch to the OFF position (Fig. C).

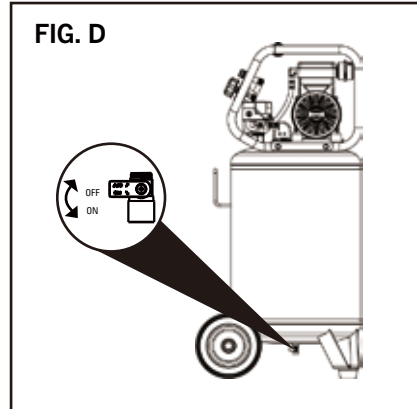
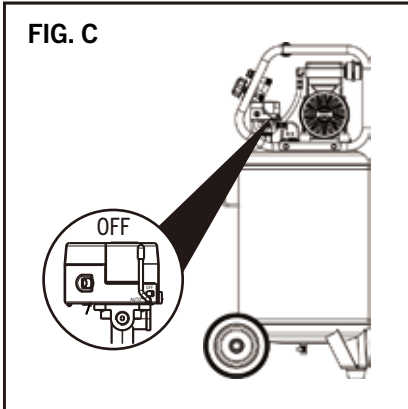

2. Open tank drain valve by turning it counter-clockwise to permit the air to escape and prevent air pressure build-up in the air tank during the break-in period (Fig. 3).
3. Turn the air pressure regulator knob (1) counter-clockwise until it stops (Fig. E).

4. Plug in the power cord

Use a dedicated circuit. The compressor will use the full capacity of a typical 12A household circuit. If any other electrical devices are drawing from the compressor's circuit, the air compressor may fail to start. Low voltage or an overload circuit can result in sluggish starting that causes the motor overload protection system or circuit breaker to trip, especially in cold conditions.

Disconnect the power cord only after break-in process has been completed, otherwise the motor might get damaged.

5. Set the ON/OFF switch to the ON position. The compressor will start. Run the compressor for 30 minutes. Please note that breaking-in the unit is only required prior to first use (Fig. F).

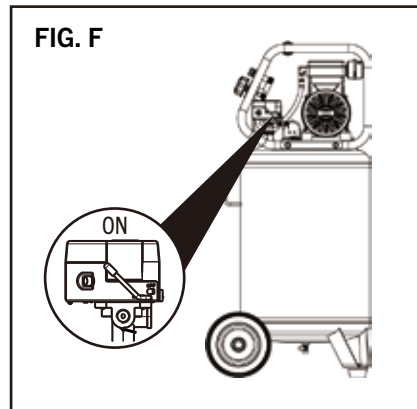
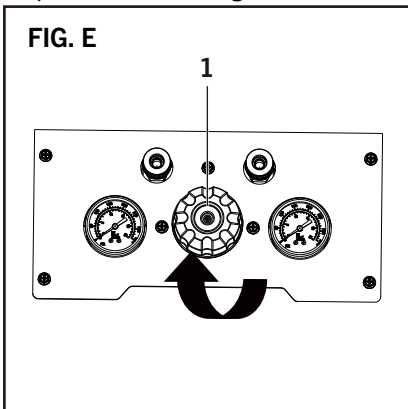

**⚠️ WARNING**

High pressure air could result in death or serious injury. Never operate above maximum operating pressure of the spray gun or tool.

**⚠️ WARNING**

Hot compressor surfaces could result in serious injury. Allow compressor to cool before touching.

**⚠️ CAUTION**

If the pump has been transported or turned upside down (even partially), allow the pump to sit in a normal, upright position (FIG. A) for approximately 10 minutes before starting.

6. After 30 minutes, turn off the ON/OFF switch.
7. Close the tank drain valve (1) by turning it clockwise (Fig. F).
8. Set the ON/OFF switch to the ON position. The air receiver will fill to "cut-out" pressure and then the compressor's motor will stop. The compressor is now ready for use.

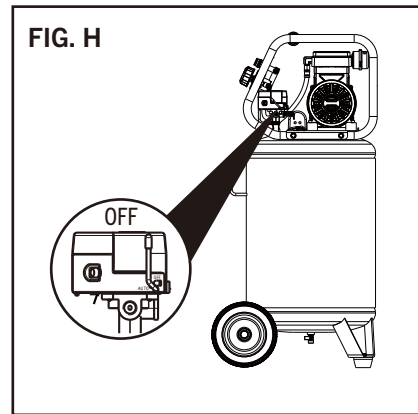
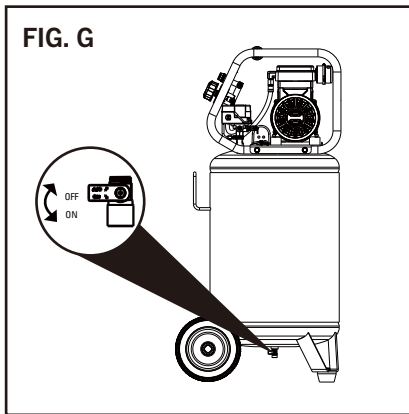
**⚠️ WARNING**

Risk of serious eye injury from moisture and debris. Always wear ANSI Z87.1 safety goggles when opening ball valve.

**⚠️ WARNING**

High pressure air could result in death or serious injury. Shut off unit, unplug and release air pressure prior to servicing.

**⚠️ CAUTION**

High pressure air containing water condensation could result in minor or moderate injury. Do not spray at any person.

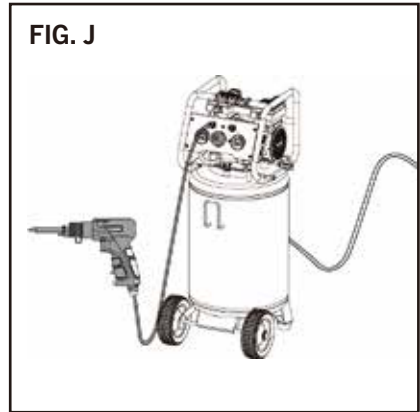
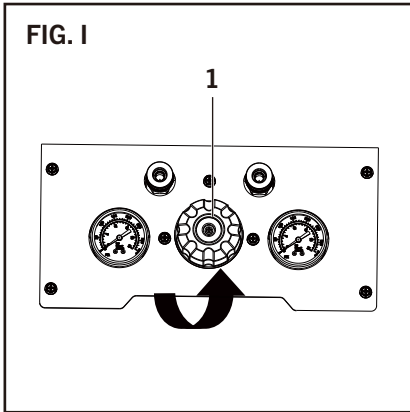

### Before Each Start-up

1. Set the ON/OFF switch (1) to the OFF position (Fig. H).
2. Turn the air pressure regulator knob (1) counter-clockwise until it stops (Fig. I).
3. Attach hose and accessories (Fig. J). (Hose and accessories need to be purchased separately.)

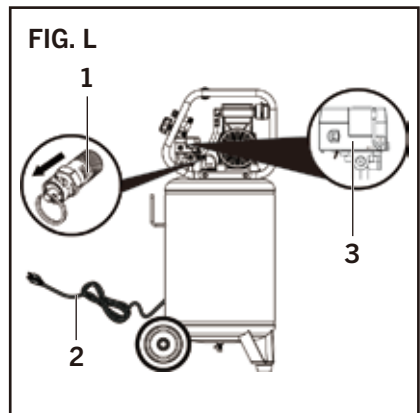
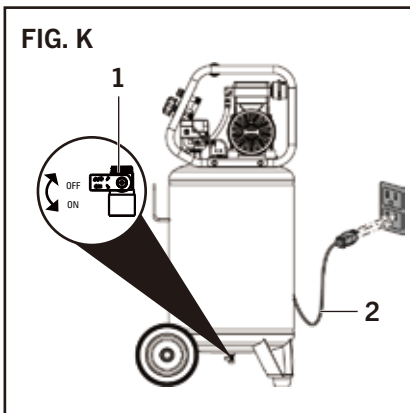

### How To Start

1. Close the tank drain valve (1) (Fig. K).
2. Plug-in the power cord (2) (Fig. H).
3. Set the ON/OFF switch to the ON position and allow the tank pressure to build. Motor will stop when tank pressure reaches cut-out pressure.
4. Turn the air pressure regulator knob clockwise until desired pressure is reached.
5. The compressor is ready for use.

### How To Shut Down

1. Set the ON/OFF switch (1) to the OFF position.
2. Unplug the power cord (2).
3. Reduce the pressure in the tank through the outlet hose. Pulling the safety valve ring (3) and keeping it open will also reduce the pressure in the tank (Fig. L).
4. Set the tank drain valve (1) (fig K) to ON to ensure tank is drained.

## MAINTENANCE

ITEM	DESCRIPTION / REASON	SERVICE INTERVAL
Drain the tank	Through normal operation of your air compressor, condensation water will accumulate in the tank. To prevent corrosion of the tank from the inside, condensation must be drained at the end of every workday. Be sure to wear protective goggles. Relieve the air pressure in the system then open the ball valve on the bottom of the tank to drain. Under cold conditions it is especially important to drain the tank after each use to reduce the chance of problems resulting from the freezing of condensation water. NOTE: Refer to instructions on how to drain tank (page 14).	Daily
Check the valve	Pull/actuate the safety valve daily to ensure that it is operating properly and to clear the valve of any possible obstructions.	Daily
Test for leaks	Check that all connections are tight. Small leaks in the tank, hoses, connections or transfer tubes will substantially reduce the air compressor and tool performance. Spray a small amount of soapy water around the area of suspected leaks with a spray bottle. If bubbles appear, repair: replace or reseal the faulty component. Do not over-tighten any connections.	Monthly
Storage	Before storing the air compressor compressor: <ul style="list-style-type: none"> <li>· Drain tank (page 14).</li> <li>· Use an air blow gun to clean all dust and debris from the pressor.</li> <li>· Disconnect and wind up the power cord.</li> <li>· Clean the ventilation openings on the motor enclosure with a damp cloth.</li> <li>· Drain all moisture from the tank.</li> <li>· Pull the pressure safety valve to release all pressure from the tank.</li> <li>· Cover the entire unit to protect it from moisture and dust.</li> <li>· Store the air compressor in a clean and dry location.</li> <li>· In cold weather, store the compressor in a warm building when it is not in use. This will reduce problems related to starting the motor and the freezing of water condensation.</li> </ul>	Prior to storing

### Check Safety Valve

Before starting compressor, pull the ring on the safety valve to make sure that the safety valve operates freely. If the valve is stuck or does not operate smoothly, contact a trained service technician.

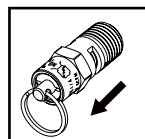

### Drain The Tank

1. Set the power switch to the O (OFF) position.
2. Turn air pressure regulator knob counter-clockwise to set the outlet pressure to zero.
3. Pull and hold ring on safety valve, allowing air to bleed from the tank until air pressure is minimized.
4. Place a suitable container under the unit to catch any water.

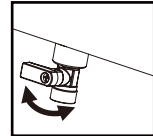

### How to Clean The Air Filter

A dirty filter will reduce the unit's performance and life. To avoid any contamination inside the pump, the filter should be cleaned weekly and replaced on a regular basis. The cartridge filter should be cleaned with blow gun.

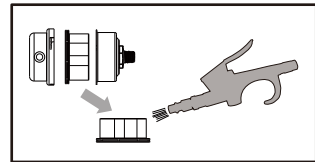

## ASSEMBLY INSTRUCTIONS

PROBLEM	POSSIBLE CAUSE	SOLUTIONS
The motor will not run or start	The power cord is not plugged in.	Plug the power cord into a grounded outlet.
	The power switch is in the O (OFF) position.	Set the power switch to the ON position.
	The extension cord is the wrong wire gauge or is too long.	Check extension cord information (page 6) for the proper wire gauge and cord length.
	The motor's thermal overload protection has tripped.	Turn the air compressor off, unplug the power cord and wait until the motor has cooled down. Plug in the power cord only after the motor has cooled down, and wait for at least 5 minutes to make sure the thermal overload protector has recovered.

The motor will not run or start	A fuse has blown or a circuit breaker has been tripped.	Replace the fuse or reset the circuit breaker.
		Verify that the fuse has the proper amperage.
		Check for low voltage conditions.
		Disconnect any other electrical appliances from the circuit or operate the compressor on a dedicated circuit.
	The air tank pressure exceeds the preset power switch limit.	The motor will start automatically when the tank pressure drops below the cut-in pressure.
The safety valve is stuck open.	Clean or replace the safety valve.	
Electrical connections are loose.	Contact an authorized service center.	
The motor, capacitor, or safety valve is defective.	Contact an authorized service center.	
The motor runs continuously when the power switch is in the ON position.	The power switch does not shut off the motor when the air compressor reaches the cut-out pressure and the safety valve activates.	Set the power switch to the OFF position. If the motor does not shut off, unplug the air compressor. If the power switch is defective, replace it.
	The compressor's capacity is not enough.	Check the air requirements of the accessory that is being used. If it is higher than the CFM (Cubic Feet per Minute) and pressure supplied by the compressor (page 7), a larger capacity air compressor is needed. Most accessories are rated at 25% of actual CFM while running continuously.

The regulator does not regulate the pressure.	The regulator or its internal parts are dirty or damaged.	Replace the regulator.
The pressure is low or there is not enough air.	There is a leak at one of the fittings.	Check the fittings with soapy water. Tighten or reseal leaking fittings (apply plumber's tape on threads). Do not over tighten.
	The tank ball valve is open.	Close the ball valve.
	The air intake is restricted.	Clean or replace the air filter element.
	Prolonged excessive use of air.	Decrease the amount of air used.
	There is a hole in the air hose.	Check the air hose and replace it if necessary.
	The tank leaks.	Replace the tank immediately. Do not attempt to repair it. Replace the tank
	The valve is leaking.	Check for worn parts and replace them if necessary. Check for worn parts and replace them if necessary.
There is moisture in the discharge air.	There is condensation in the air tank caused by a high level of atmospheric humidity or because the air compressor has not been running long enough.	Drain the air tank after each use. Drain the air tank more often in humid weather and use an air-line filter.
The compressor overheats.	The ventilation is inadequate.	Relocate the compressor to an area with
	Cooling surfaces are dirty.	Clean all cooling surfaces on the pump
	The valve is leaking.	Replace worn parts and reassemble using new plumber's tape.

20 GAL(75.7L) AIR COMPRESSOR

**1635-712**

## EXPLODED VIEW

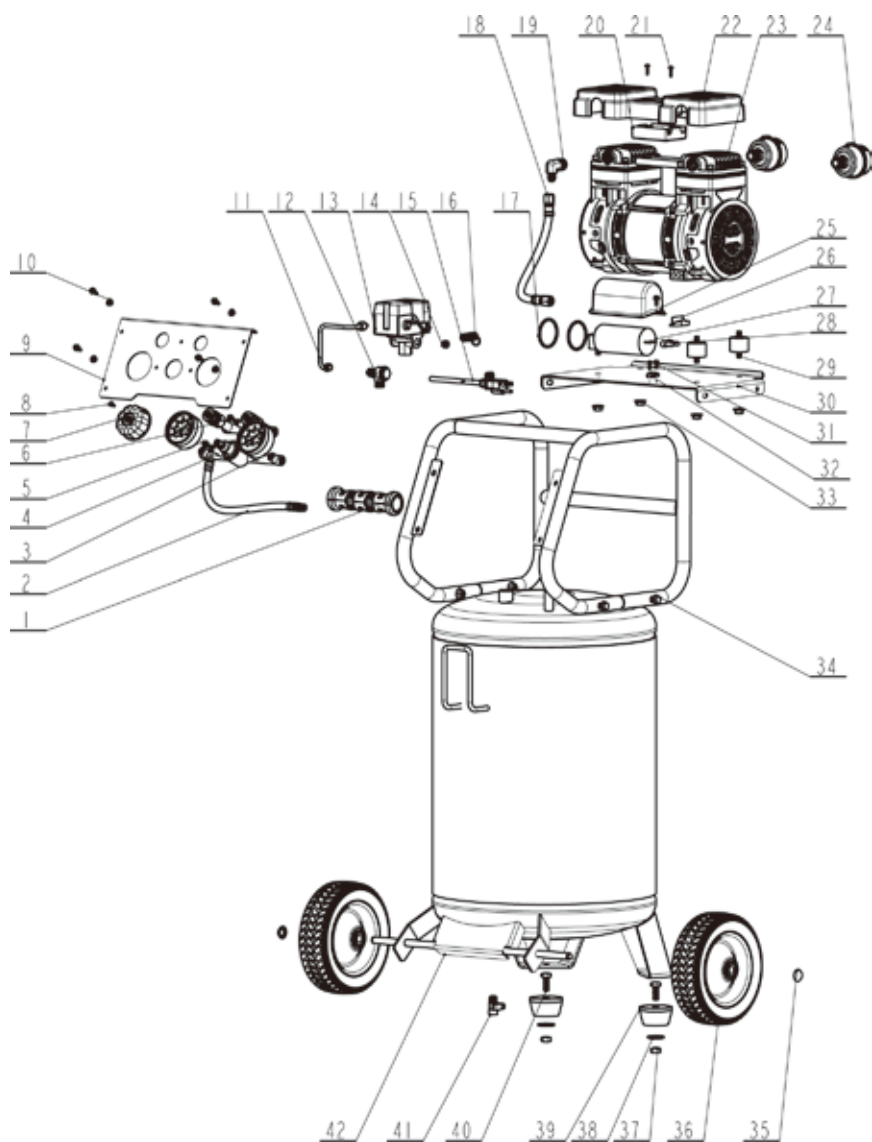

**PARTS LIST**

KEY#	PART NAME	QUANTITY
1	Handgrip	1
2	Rubber Hose	1
3	Pressure Gauge	2
4	Pressure Regulator	1
5	Screw M5x12	9
6	Quick Coupler	2
7	Pressure Regulator Knob	1
8	Screw M4x10	1
9	Control Panel	1
10	Flange Nut M5	7
11	Aluminum Tube	1
12	Check Valve	1
13	Pressure Switch	1
14	End Cap	1
15	Power Cord	1
16	Safety Valve	1
17	O-Ring	2
18	Metal Tube	1
19	Elbow Fitting	1
20	Retainer	1
21	Self-Tapping Screw ST3.9x16F	2
22	Pump Cover	1
23	Motor Pump Assembly	1
24	Air Filter	2
25	Capacitor Shroud	1
26	Capacitance Plug	1
27	Capacitor	1
28	Crimp Cap	2
29	Cushion Pad	4
30	Mount Plate	1
31	Screw M4x12	2

32	Cord Clamp	1
33	Flange Nut M8	8
34	Screw M8x40	4
35	Bonnet	2
36	Wheel	2
37	Flange Nut M10	2
38	Washer Ø10	2
39	Rubber Foot	2
40	Bolt M10x25	2
41	Drain Valve	1
42	Tank	1

## **WARRANTY**

### **BENCHMARK WARRANTY**

If this Benchmark tool fails due to a defect in material or workmanship within three years from the date of purchase, return it to any Home Hardware store with the original bill of sale for further analysis.

This warranty does not include expendable parts including but not limited to blades, brushes, belts, light bulbs.

This warranty covers defects in material or workmanship only. It does not cover normal wear and tear, failure due to abuse/misuse, or defects caused by careless or accidental mishandling. If this Benchmark product is used for commercial or rental purposes, this warranty does not apply.

# 20 GAL(75.7L) AIR COMPRESSOR



3 year limited warranty

**BENCHMARK**<sup>TM</sup>  
MC

**BENCHMARK TOOLS CANADA**

ST. JACOBS, ONTARIO N0B 2N0

© 2021 Home Hardware Stores Limited

**CUSTOMER SERVICE/TECH SUPPORT**

1-866-349-8665

**1635-712**

Made in China



\*This Benchmark<sup>TM</sup> product carries a three (3) year LIMITED warranty against defects in workmanship and materials. See Owner's Manual for full details.



**READ ALL INSTRUCTIONS BEFORE FIRST USE.  
KEEP THIS MANUAL FOR FUTURE REFERENCE.  
KEEP AWAY FROM CHILDREN.**



**WEAR CSA APPROVED  
EYE PROTECTION**



**WEAR EAR  
PROTECTION**



**WEAR A  
FACE MASK**