

# BENCHMARK™ MC

## 12" SLIDING COMPOUND MITRE SAW 1347-006



5 Year Limited Warranty



**READ ALL INSTRUCTIONS BEFORE FIRST USE.  
KEEP THIS MANUAL FOR FUTURE REFERENCE.  
KEEP AWAY FROM CHILDREN.**



**WEAR CSA APPROVED  
EYE PROTECTION**



**WEAR EAR  
PROTECTION**



**WEAR A FACE  
MASK**

## PRODUCT SPECIFICATIONS

<b>12" SLIDING COMPOUND MITRE SAW</b>	
Motor:	120V AC, 60Hz
Amperes:	15 AMP
Speed:	3,800 RPM (no load)
Blade:	12" 48 tooth general purpose carbide-tipped
Arbor size:	1"
Laser:	Class II
Laser wavelength:	650nm
Laser output power:	<1mW
Mitre range:	0–45° left & right
Bevel range:	0–45° left & right
Cutting capacity:	90° cross cut 3 ½" (9cm) x 13 ⅜" (34cm) 45° mitre cut 3 ½" (9cm) x 9 7/16" (24 cm) 45° bevel cut 2 ⅛" (5.5 cm) x 13 ⅜" (34 cm) 45° mitre/bevel cut 2 ⅛" (5.5 cm) x 9 7/16" (24 cm)
Replacement Blade	1221-033
Weight:	58.4 lb. (26.5 kg)

### NEED ASSISTANCE?

Call us on our toll- free customer support line:

1-866-349-8665 (Monday through Friday 9am – 5pm

Eastern Standard Time)

- Technical questions
- Replacement parts
- Parts missing from package

**TABLE OF CONTENTS**



Product Specifications.....1  
Table of Contents.....2  
General Safety Warnings.....3-4  
Specific Safety Rules.....5-6  
Symbols.....7  
Extension Cord Safety.....8-9  
Know Your 12" Sliding Compound Mitre Saw.....10  
Assembly and Operation.....11-22  
Maintenance.....23-25  
Explosion Drawing.....26  
Parts List.....27-31  
Warranty.....32

## GENERAL SAFETY WARNINGS



### WARNING:

Before using this tool or any of its accessories, read this manual and follow all Safety Rules and Operating Instructions. The important precautions, safeguards and instructions appearing in this manual are not meant to cover all possible situations. It must be understood that common sense and caution are factors which cannot be built into the product.

SYMBOL	MEANING
	<p><b>ALWAYS WEAR EYE PROTECTION THAT CONFORMS WITH CSA Z94.3 or ANSI SAFETY STANDARD Z87.1</b></p> <p>FLYING DEBRIS can cause permanent eye damage. Prescription eyeglasses ARE NOT a replacement for proper eye protection.</p> <p><b>Non-compliant eyewear can cause serious injury if broken during the operation of a power tool.</b></p>
	<p>Use hearing protection, particularly during extended periods of operation of the tool, or if the operation is noisy.</p>
	<p><b>WEAR A DUST MASK THAT IS DESIGNED TO BE USED WHEN OPERATING A POWER TOOL IN A DUSTY ENVIRONMENT.</b></p> <p>Dust that is created by power sanding, sawing, grinding, drilling, and other construction activities may contain chemicals that are known to cause cancer, birth defects, or other genetic abnormalities.</p> <p>These chemicals include:</p> <ul style="list-style-type: none"> <li>• Lead from lead-based paints</li> <li>• Crystalline silica from bricks, cement, and other masonry products</li> <li>• Arsenic and chromium from chemically treated lumber</li> </ul> <p>the level of risk from exposure to these chemicals varies, according to how often this type of work is performed. In order to reduce exposure to these chemicals, work in a well-ventilated area, and use approved safety equipment, such as a dust mask that is specifically designed to filter out microscopic particles.</p>

## READ ALL INSTRUCTIONS

 **WARNING!** Read and understand all instructions before using this tool. The operator must follow basic precautions to reduce the risk of personal injury and/or damage to the equipment.

### WORK AREA SAFETY

- Keep guards in place and in working order.
- Remove adjusting keys and wrenches. Form habit of checking to see that keys and adjusting wrenches are removed from tool before turning it on.
- Keep work area clean. Cluttered areas and benches invite injuries.
- Don't use in dangerous environments. Don't use power tools in damp or wet locations, or expose them to rain or snow. Keep work area well lighted.
- Keep children away. All visitors should be kept at a safe distance from work area.
- Make workshop childproof with padlocks, master switches, or by removing starter keys.
- Don't force the tool. It will do the job better and safer at the rate for which it was designed.
- Use the right tool. Don't force tool or attachment to do a job for which it was not designed.
- Wear proper apparel. Do not wear loose clothing, gloves, neckties, rings, bracelets, or other jewellery which may get caught in moving parts. Non-slip footwear is recommended. Wear protective hair covering to contain long hair.
- Always use safety glasses. Also use face or dust mask if cutting operation is dusty. Everyday eyeglasses only have impact-resistant lenses, they are not safety glasses.
- Secure work. Use clamps or vise to hold work when practical. It's safer than using your hand and it frees both hands to operate tool.
- Don't overreach. Keep proper footing and balance at all times.
- Maintain tools with care. Keep tools sharp and clean for best and safest performance. Follow instructions for lubricating and changing accessories.
- Disconnect tools before servicing; when changing accessories, such as blades, clamps, extensions, and the like.
- Reduce the risk of unintentional starting. Make sure the switch is in the OFF position before plugging in.
- Use recommended accessories. Consult the owner's manual for recommended accessories. The use of improper accessories may cause risk of injury to persons.
- Never stand on tool. Serious injury could occur if something unintentionally comes into contact with the cutting tool.
- Check damaged parts. Before further use of the tool, a guard or other part that is damaged should be carefully checked to determine whether it will operate properly and perform its intended function - check for alignment of moving parts, binding of moving parts, breakage of parts, mounting, and any other conditions that may affect its operation. A guard or other part that is damaged should be properly repaired or replaced.
- Direction of feed. Feed work into a blade or cutter against the direction of rotation of the blade or cutter only.
- Never leave tool running unattended. Turn power off. Don't leave tool until it comes to a complete stop.

### ELECTRICAL SAFETY

This compound mitre saw is a double-insulated tool. To reduce the risk of electric shock, double-insulated tools are equipped with a polarized plug (one blade is wider than the other). This plug will fit into a polarized outlet only one way. If the plug does not fit into the outlet properly, reverse the plug. If it still does not fit, contact a qualified electrician to install a polarized outlet. Do not change the plug in any way.

Double insulation eliminates the need for the three-wire grounded power cord and grounded power supply system.

Before plugging in the tool, BE SURE that the outlet voltage supplied is within the voltage marked on the tool's data plate. DO NOT use "AC only" rated tools with a DC power supply. Avoid body contact with grounded surfaces such as pipes, radiators, ranges and refrigerators. There is an increased risk of electric shock if your body is grounded.

DO NOT expose power tools to rain or wet conditions and do not use power tools in wet or damp locations. Water entering a power tool will increase the risk of electric shock. This tool is intended for indoor use only.

If operating a power tool in damp locations is unavoidable, ALWAYS USE a power supply for your tool that is protected by a Ground Fault Circuit Interrupter. ALWAYS WEAR electrician's rubber gloves and footwear in damp conditions.

Inspect tool cords for damage. Have damaged tool cords repaired by a qualified person. BE SURE to stay constantly aware of the cord location, and keep it well away from the moving blade.



Do not abuse the cord. Never use the cord for carrying, pulling or unplugging the power tool. Keep cord away from heat, oil, sharp edges and moving parts. Replace damaged cords immediately. Damaged cords increase the risk of electric shock.

Use proper extension cord. Make sure your extension cord is in good condition. When using an extension cord, be sure to use one heavy enough to carry the current your product will draw. An undersized cord will cause a drop in line voltage resulting in loss of power and overheating. See extension cord chart.

Do not disconnect the power cord in place of using the power switch. This will prevent an accidental start-up when the power cord is plugged into the power supply.

In the event of a power failure, turn off or unplug the tool as soon as the power is interrupted. The possibility of accidental injury could occur if the power returns and the unit is not switched off.

Make certain the power source conforms to requirements of your equipment.

Do not use any adapter plugs.

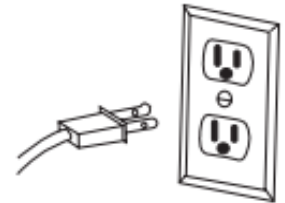

## SERVICE

Have your power tool serviced by a qualified repair person using only identical replacement parts. This will ensure that the safety of the power tool is maintained.

## SPECIFIC SAFETY RULES



**WARNING!** DO NOT let comfort or familiarity with product (gained from repeated use) replace strict adherence to the tool safety rules. If you use this tool unsafely or incorrectly, you can suffer serious personal injury.

**DANGER!** When the tool is in operation, keep hands away from the saw blade and the area it is being applied to.

Failure to follow this warning will result in amputation, serious personal injury or death

**WARNING!** Some surfaces contain materials which can be toxic. When working on materials that may contain lead, asbestos, copper chromium arsenate or other toxic materials, extra care should be taken to avoid inhalation and minimize skin contact.

1. Always wear eye protection.
2. Do not operate the saw without guards in place.
3. Be sure to turn the tool off and wait for the saw blade to stop before moving the workpiece or changing settings.
4. Be sure that the power is disconnected before changing the blade or servicing the saw.
5. Do not expose to rain or use in a damp location.
6. When servicing, use only identical replacement parts.
7. Never reach around the saw blade.
8. Do not perform any operation freehand. Always place the workpiece to be cut on the mitre saw table and position it firmly against the fence as a backstop. Always use the fence.
9. Always keep hands out of the path of the saw blade. Do not reach under the material being cut or into the blade's cutting path with your fingers or hand for any reason.
10. To reduce the risk of injury, return the cutting head to the full rear position after each crosscut operation.
11. Always make sure that the mitre table and head assembly (bevel function) are locked in position before operating your saw. Lock the mitre table by securely tightening the mitre locking handle. Lock the head assembly (bevel function) by securely tightening the bevel locking knob.
12. Be sure the blade path is free of nails. Always carefully inspect lumber and remove all nails BEFORE cutting.
13. Always be sure the blade clears the workpiece. Never start the saw with the blade touching the workpiece. Always allow the motor to come up to full speed before starting a cut.
14. Support long workpieces when cutting to minimize the risk of blade pinching or kickback. The saw may slip, walk or slide while cutting long or heavy boards.
15. Never use a length-stop on the free end of a clamped workpiece. Never hold onto or bind the free end of the workpiece in any operation. If a clamp and length-stop are used together, they must both be installed on the same side of the saw table to prevent the saw from catching the loose end and kicking up.
16. Never cut more than one piece at a time. Do not stack more than one workpiece on the worktable at a time.

17. Avoid awkward operations and hand positions where a sudden slip could cause your hand to hit the blade. Always make sure you have good balance. Never operate your saw on the floor or in a crouched position.
18. Use the correct tool for the job. This tool was designed for a specific function. Do not modify or alter this tool or use it for an unintended purpose.
19. Do not use the tool if any parts are damage broken or misplaced. Repair or replace the parts.
20. Only use a blade that is specifically designed for use with the mitre saw. Ensure the blade is tightly installed.
21. Do not use a blade that is dull or damaged. When a blade is dull, it requires more force to use the tool, possibly causing the blade to break. This may cause an injury and will damage the workpiece. A dull or improperly set saw blade produces a narrow kerf that can cause excessive friction on the saw blade, resulting in binding or a kickback. Keep the saw blade's edge sharp and clean.
22. Only use a blade that exceeds the Speed Rating
23. Use the correct mounting hardware. The mounting hardware is designed to hold the blade on the tool to allow optimum performance and safety of operation. Mismatched mounting hardware may result in a tool malfunction and cause an injury.
24. Always use a blade that is correctly sized and shaped for the tool. Accessories that do not match the tool's mounting hardware will run erratically, causing loss of control.
25. Check the blade for damage before each use. A damaged blade can break during use and cause serious injury.
26. Always handle the blade with care when mounting or removing it.
27. Remove adjusting keys and wrenches before using the tool. The tool may eject an attached wrench or a key and cause an injury to you or a bystander.
28. Never lift this tool by gripping the switch handle or by the mitre fence. This may cause misalignment. Always lock the head assembly in the "Down" position and carry the saw by holding the base or lift it using the carrying handle/support bracket.

## **POWER TOOL PRECAUTIONS**

1. Do not use any power tool with a malfunctioning power switch or control. A power tool that fails to respond to the controls is dangerous and can cause an injury. A qualified technician must repair and verify the power tool is operating correctly, before it can be used.
2. Shut the power off and disconnect the mitre saw from the power supply before making any adjustments, changing accessories, cleaning, servicing or when storing. Such preventive safety measures reduce the risk of starting the tool accidentally.
3. Never force the mitre saw. Excessive pressure could break the tool, resulting in damage to your workpiece or serious personal injury. Excessive pressure is the cause if your tool runs smoothly under no load, but roughly under load.
4. Check if the mitre saw's moving parts are misaligned or binding before each use. Correct the issue before using the mitre saw to avoid an injury or damage to the tool.
5. Always be aware of the position of your hands relative to the mitre saw. Avoid awkward hand positions where a sudden slip could cause a hand to move into the circular saw disc. Never reach behind or beneath the mitre saw.
8. Before using the mitre saw on a workpiece, test the mitre saw by running it at the highest speed rating for at least 30 seconds in a safe position. Stop immediately if there is any abnormal vibration or wobbling. Check the tool to determine the cause.
9. Never touch the circular saw blade or workpiece during or immediately after use. They may be hot and could inflict a burn injury.
10. The material and the motor housing can get very hot during operation. Stop work until the mitre saw and the blade both cool down to a safe temperature.
11. Do not cover the air vents. Proper cooling of the motor is necessary to ensure normal life of the tool.
12. Never use a tool with a blade that is cracked or worn. Change the blade before using it.
13. Avoid unintentional starts. Make sure the power switch is set to OFF before connecting the mitre saw to a power supply.
14. Make sure any adjustment mechanisms are secure before using the tool.

## **KICKBACK PRECAUTIONS**





Kickback is a sudden reaction to a pinched or snagged cutting accessory caught on the material. The material can be rejected and inflict a serious injury on the user or a bystander. Kickback can also damage the tool or workpiece. Kickback can be avoided by taking proper precautions:









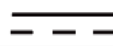

1. Maintain a firm grip on the material and position your body and arms to allow you to resist a kickback. Kickback can propel the material in the direction of the mitre saw's rotation.
  - a. Use a clamp to hold the material if the tool includes a clamping system.
2. Use special care when working on corners, sharp edges or flexible material. These workpieces have a tendency to snag the blade.
3. Only use a blade designed for the tool.
4. Always make sure the work surface is free from nails and other foreign objects. Cutting into a nail can cause the tool to jump and damage blade.

## SAFETY SYMBOLS



**WARNING:** Some of the following symbols may appear on your tool. Study these symbols and learn their meaning. Proper interpretation of these symbols will allow for more efficient and safer operation of this tool.

V	Volts
A	Amperes
Hz	Hertz
W	Watts
kW	Kilowatts
μF	Microfarads
L	Litres
kg	Kilograms
H	Hours
N/cm <sup>2</sup>	Newtons per square centimetre
Pa	Pascals
OPM	Oscillations per minute
Min	Minutes
S	Seconds
 or a.c.	Alternating current
	Three-phase alternating current
	Three-phase alternating current with neutral
	Read all safety warnings and instructions

	Direct current
$n_0$	No load speed
	Alternating or direct current
	Class II construction
	Splash-proof construction
	Watertight construction
	Protective grounding at grounding terminal, Class I tools
tr/min	Revolutions or reciprocations per minute
∅	Diameter
0	Off position
	Directional Arrow
	Warning symbol
	Wear your safety glasses
	Wear hearing protection



This symbol designates that this tool is listed with CSA requirements by CSA Testing Laboratories. Conforms to CSA CAN/CSA-C 22.2 NO. 71.2-10 and ANSI/UL Std. No. 987-7.

## EXTENSION CORD SAFETY

Use proper extension cord . Make sure your extension cord is in good condition . When using an extension cord , be sure to use one heavy enough to carry the current your product will draw . An undersized cord will cause a drop in line voltage resulting in loss of power and overheating . The following table shows the correct size to use depending on cord length and nameplate ampere rating . If in doubt , use the next heavier gauge . The smaller the gauge number , the heavier the cord.

MINIMUM GAUGE(AWG)EXTENSION CORDS (120V) USE ONLY					
Amperage rating		Total length			
More than	Not more than	25' (7.5 m)	50' (15 m)	100' (30 m)	150' (45 m)
	6	18	16	16	14
6	10	18	16	14	12
10	12	16	16	14	12
12	16	14	12	Not Applicable	

## SAFETY RULES FOR LASER LIGHTS

**THE WER LIGHT/WER RADIATION USED IN THE SYSTEM IS CWS 2 WITH MAXIMUM 1MWAND 650NM WAVELENGTHS. THESE LASERS DO NOT NORMALLY PRESENT AN OPTICAL HAZARD, ALTHOUGH STARING AT THE BEAM MAY CAUSE FLASH BLINDNESS.**

 **WARNING:** Do not stare directly at the laser beam

A hazard may exist if you deliberately stare into the beam, please observe all safety rules as follows;

- The laser shall be used and maintained in accordance with the manufacturer's instructions.
- Never aim the beam at any person or an object other than the workpiece.
- The laser beam shall not be deliberately aimed at personnel and shall be prevented from being directed towards the eye of a person for longer than 14 seconds.
- Always ensure the laser beam is aimed at a sturdy workpiece without reflective surfaces ie. Wood or rough coated surfaces are acceptable. Bright shiny reflective sheet steel or the like is not suitable for laser use as the reflective surface could direct the beam back at the operator.
- Do not change the laser light assembly with a different type. Repairs must be carried out by an authorised agent.



<b>Attention! - laser radiation</b> <b>Do not stare into beam!</b>	<b>Attention! - rayonnement laser</b> <b>Ne pas fixer le faisceau!</b>
class 2 laser product laser specification according to	produit laser de classe 2 spécification laser selon
$\lambda = 650 \text{ nm}$ $P_0 < 1 \text{ mW}$	$\lambda = 650 \text{ nm}$ $P_0 < 1 \text{ mW}$

**CAUTION:** Use of controls or adjustments or performance of procedures other than those specified herein may result in hazardous radiation exposure.



**WARNINGS.**

- Do not stare directly at the laser beam. Never aim the beam at any person or an object other than the workpiece.
- Do not deliberately aim the beam at personnel and ensure that it is not directed towards the eye of a person for longer than 14 seconds.
- Always ensure the laser beam is aimed at a sturdy workpiece without reflective surfaces. Wood or rough coated surfaces are acceptable. Bright shiny reflective surfaces are not suitable for laser use as the reflective surface could direct the beam back at the operator.
- Always remember to switch off the laser on / off switch after finishing a job. Only turn the laser beam on when the workpiece is on the mitre saw table. Mark the line of the cut on the workpiece.

## KNOW YOUR 12" COMPOUND SLIDING MITRE SAW

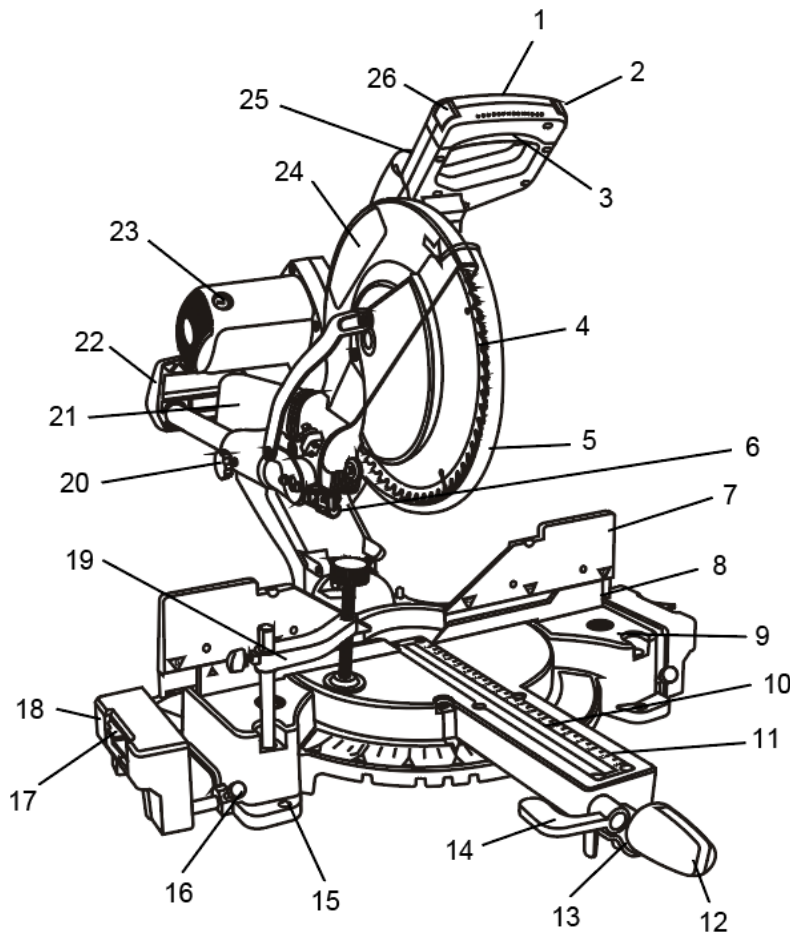

- |                                 |  |
|---------------------------------|--|
| 1. Front handle                 | 16. Base extension locking knob                |
| 2. Lock-off switch              | 17. Cut-off stop                               |
| 3. Trigger switch               | 18. Base extension                             |
| 4. Blade                        | 19. Hold-down clamp                            |
| 5. Lower blade guard            | 20. Slider friction knob                       |
| 6. LED worklight & laser module | 21. Dust bag                                   |
| 7. Fence extensions             | 22. Rear handle                                |
| 8. Fence                        | 23. Motor brushes                              |
| 9. Base                         | 24. Upper blade guard                          |
| 10. Kerf slot                   | 25. LED worklight & laser module ON/OFF switch |
| 11. Table insert                | 26. Lock-off switch                            |
| 12. Miter locking knob          |  |
| 13. Miter primary detent lock   |  |
| 14. Bevel locking lever         |  |
| 15. Mounting bolt holes         |  |

## ASSEMBLY AND OPERATION

### CUTTING HEAD LOCK-DOWN

This mitre saw is shipped with the cutting head locked in the DOWN position. The lock-down system must be used when moving, transporting or lifting the mitre saw to prevent the cutting head from shifting. It also makes lifting the mitre saw easier and safer.

**⚠ WARNING:** Never turn the mitre saw ON when the cutting head is locked in the DOWN position. Always unlock the lock-down pin and allow the cutting head to rise to its maximum height before turning the mitre saw ON.

To unlock the lock-down pin:

1. Use your left hand to slightly push downward on the main handle .
2. While holding the main handle down, use your right hand to pull the lock-down knob (1) outward, rotate it 1/4 turn and release the knob.
3. Lift your left hand and allow the cutting head to rise to its maximum height.

To lock the cutting head in the DOWN position, pull outward on the lock-down knob, rotate it another 1/4 turn and pull the main handle downward until the spring loaded locking pin engages and locks the cutting head DOWN.

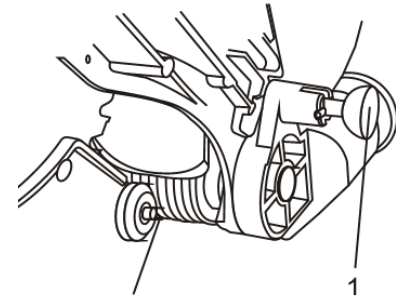

Fig. 1

### INSTALLING THE REAR BALANCE SUPPORT

1. Lock the cutting head in the down position and carefully roll the mitre saw approx. 150° counter clockwise on a clean sheet of corrugated to expose the under side of the base (Fig. 2).
  2. Use a #2  $\oplus$  screwdriver and turn the balance support locking screw (1) counter clockwise until the leg of the balance support (2) can be inserted into the hole in the base casting (3).
  3. Insert both legs (2 & 4) of the balance support into the matching holes (3 & 5) in the base casting.
- NOTE:** Make sure the turned-down portion of the balance support (6) is facing the bottom of the base casting.
4. Slide the balance support rods into the mounting holes until they protrude at least 1/2" past the casting.
  5. Tighten the balance support locking screw to lock the balance support into the base casting.
  6. Carefully turn the mitre saw upright.

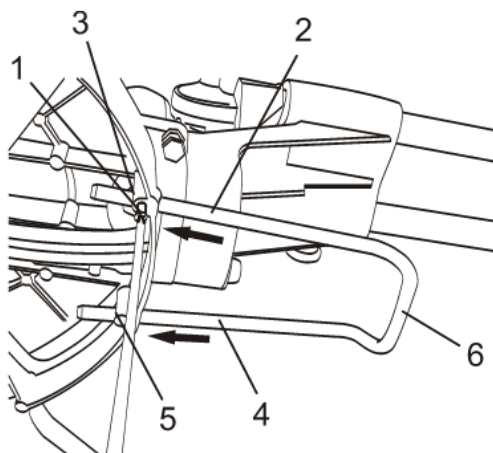

Fig. 2

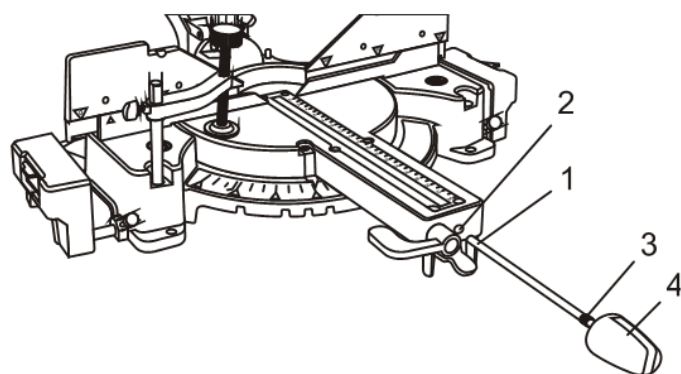

Fig. 3

## INSTALLING THE MITRE LOCKING KNOB

The mitre locking knob is used to lock the cutting head at the correct mitre angle. It is also used to change the mitre angle.

1. Insert the unthreaded end of the locking rod (1) into the threaded hole in the mitre handle (2) (Fig. 3).
2. Slide the locking rod into the mitre handle until the threaded portion of the rod (3) can be threaded into the mitre handle.  
**NOTE:** When sliding the locking rod into the mitre handle, make sure the rod slides under the retainer inside the mitre handle.
3. Turn the locking knob (4) clockwise until the end of the unthreaded portion of the rod makes firm contact with the base casting and locks the cutting head at the correct mitre angle.
4. To change the mitre angle, turn the locking knob counter clockwise until the mitre handle can be freely moved to change the mitre angle.

## INSTALLING THE BASE EXTENSION SUPPORTS

The base extension supports are designed to provide a wider surface upon which the workpiece will rest. There are two base extension supports, one for each side of the base casting. Using the base extension supports will help in producing more accurate cuts. They will also provide a "positive stop" for cutting multiple workpieces to the same length.

1. Turn the base extension support locking screw (1) counter clockwise until it does not protrude into the hole in the base casting (3) (Fig. 4).
2. Insert the two base extension support rods (2) into the matching holes in the base casting (3).

**NOTE:** Push the rods through the holes until they extend 1/2" beyond the casting.

3. Turn the locking screw clockwise to lock the base extension support in place.
4. Install the second base extension support on the opposite side of the base casting in exactly the same manner.

**NOTE:** The base extension supports can be slid fully into the base casting when they are not required for extra workpiece support.

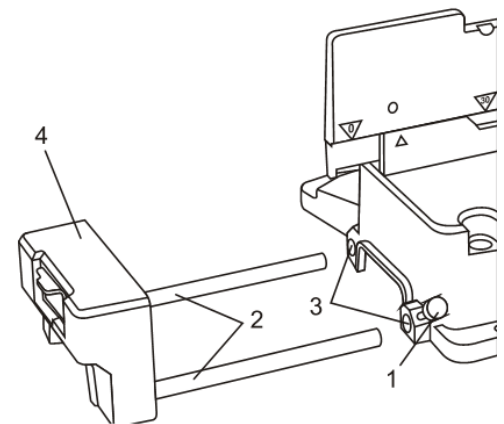

Fig. 4

## INSTALLING HOLD-DOWN CLAMP

The hold-down clamp is used to hold the long section of the workpiece firmly in place while making a cut.

1. Insert the hold-down clamp rod (1) into the clamp rod hole (2) located in the front left corner of the base (Fig. 5).

### NOTES:

- a) There is also a clamp rod hole in the left rear corner of the base that may be more convenient for holding some workpieces that are odd shapes.
- b) The left hand location of the hold-down clamp is best for right handed operators. For left handed operators, there are two matching clamp holes in the right hand side of the base.

2. Loosen the cross bar adjusting knob (3) and slide the cross bar up or down until it is approximately 3" above the base.

3. Tighten the cross bar adjusting knob.

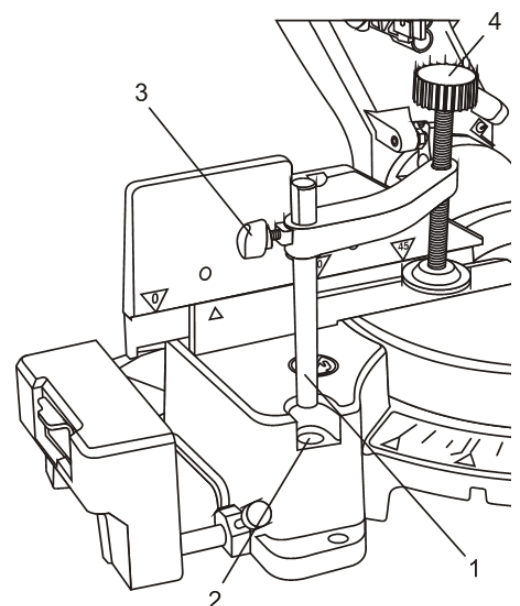

Fig. 5

## FASTENING THE MITRE SAW ONTO A STABLE WORK SURFACE

**WARNING:** It is important to securely anchor the mitre saw to a stable work surface to prevent it from shifting during use and possibly causing serious injury to the operator. It will also make the saw easier to use and promote more accurate cuts.

**NOTE:** Bolts and hardware for anchoring the mitre saw are not included. These items must be purchased separately.

It is strongly recommended to anchor the mitre saw using either 5/16" lag bolts and flat washers or appropriate 5/16" bolts through the four base casting mounting holes (1) (Fig. 6). There are two mounting holes in the front of the base casting and two in the rear of the base casting.

**NOTE:** Do not over tighten the bolts. You may break the base casting.

**WARNING:** If the mitre saw is not bolted to a stable work surface, it must be firmly clamped in place. Failure to adequately secure the mitre saw may result in serious injury.

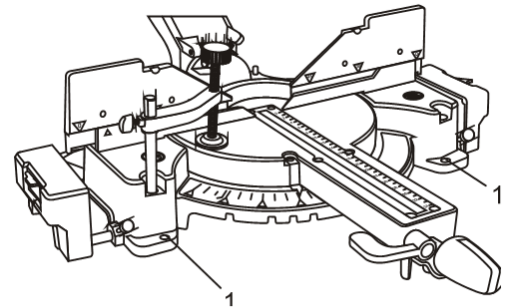

Fig. 6

## ADJUSTING THE MITRE SAW

Before making any cuts, it is important to check all adjustments to make sure the saw will function properly and cut at the proper angles. The following adjustments must be checked and appropriate adjustments made before using the mitre saw.

**WARNING:** Remove the plug from the power source before checking or making any adjustments. Failure to remove the plug could result in serious personal injury as a result of the mitre saw starting unexpectedly.

### ADJUSTING THE 0° MITRE ANGLE

The 0° mitre angle is preset at the factory. However, should it become necessary to reset, Follow these procedures:

1. Turn the mitre locking knob (1) counter clockwise 2 turns (Fig. 7).
2. Squeeze the mitre detent locking lever (2) and move the mitre arm (3) left or right until the 0° pointer (4) lines up with the 0° line on the scale.
3. Release the mitre detent locking lever and once again move the mitre arm back and forth until the detent lock drops into the matching notch (5) in the bottom of the base.
4. If the 0° pointer is not aligned directly with the 0° line on the scale, use a #2  $\oplus$  screwdriver (not provided) to loosen the pointer screw (6).

Then align the pointer with the 0° line on the scale and tighten the screw to hold the pointer firmly in place.

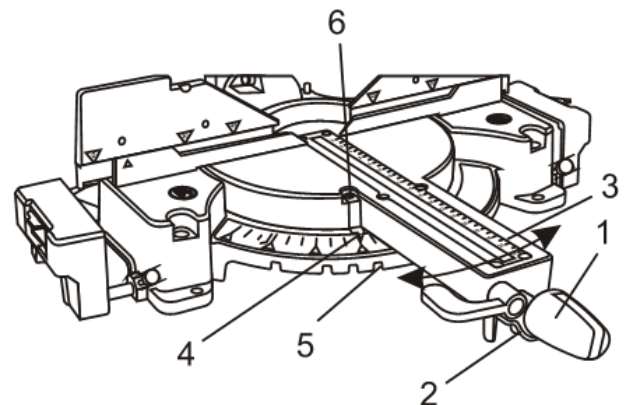
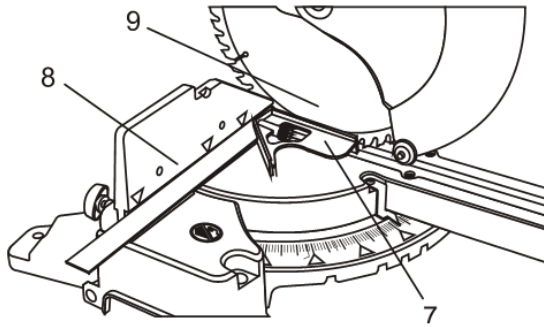

Fig. 7

Once steps #1 through #5 have been completed, it is important to verify that the 0° settings are accurate and that the blade is perpendicular to the fence as follows:

5. Lock the handle in the down position. Hold a combination square (not provided) (7) against the fence (8) and beside the saw blade (9) (Fig. 8).

**NOTE:** Make sure the square rests against the body of the blade without touching the carbide tips or teeth. When properly positioned, the full length of the combination square should contact both the saw blade and the fence. If the saw blade does not contact the full length of the combination square, adjust the fence as follows:



**Fig. 8**

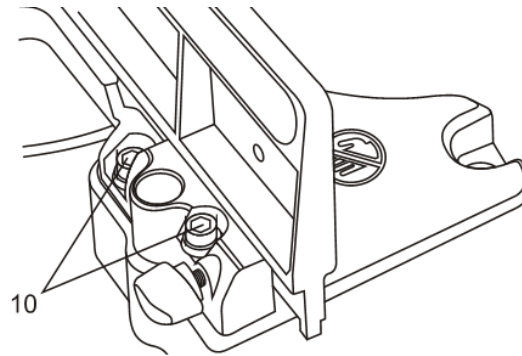
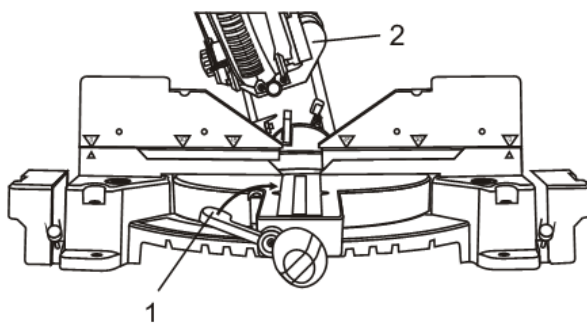

**Fig. 9**

6. Loosen the four fence adjustment screws (10) using the 6 mm hex key (provided) (Fig. 9).
7. Hold the combination square against the saw blade. Gently tap the lower edge the fence with a plastic mallet (not provided) until it contacts the full length of the combination square.
8. Tighten the fence adjustment screws and re-check the fence alignment.

## ADJUSTING THE 0° BEVEL ANGLE

1. Lift the bevel angle locking lever (1) upward and rotate it clockwise to allow the cutting head (2) to rotate (Fig. 10).



**Fig. 10**

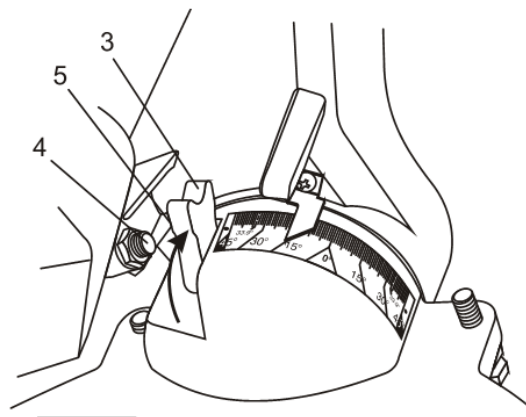

**Fig. 11**

2. Lift the 0° bevel stop (3) to the vertical position (Fig. 11).
3. Rotate the cutting head clockwise until the 0° adjustment screw (4) contacts the left hand side of the 0° bevel stop (5).
4. Rotate the bevel angle locking lever counter clockwise to lock the cutting head in the 0° position.
5. Lock the handle in the down position. Hold a combination square (not provided) (6) against the base (7) and beside the saw blade (8) (Fig. 12).

**NOTE:** Make sure the square rests against the body of the blade without touching the carbide tips or teeth. When properly positioned, the full length of the combination square should contact both the saw blade and the base. If the saw blade does not contact the full length of the combination square, adjust the bevel angle as follows:

6. Lift the cutting head to its maximum height.
7. Make sure the cutting head 0° adjustment screw is contacting the left hand side of the 0° bevel stop.
8. Insert a 4 mm hex key (provided) in the 0° bevel stop set screw (9) (Fig. 13). While holding the hex key, loosen the 0° bevel stop lock nut (10) using a 13 mm wrench (provided).
9. Use the hex key to turn the set screw in or out as required until the blade contacts the full length of the combination square.
10. While using the hex key to prevent the set screw from turning, tighten the lock nut.

**NOTE:** Re-check the alignment after tightening the lock nut.

11. If the 0° bevel pointer is not aligned directly with the 0° line on the scale, use a #2  $\oplus$  screwdriver (not included) to loosen the pointer screw (11). Then align the pointer (12) with the 0° line (13) on the scale and tighten the screw to hold the pointer firmly in place.

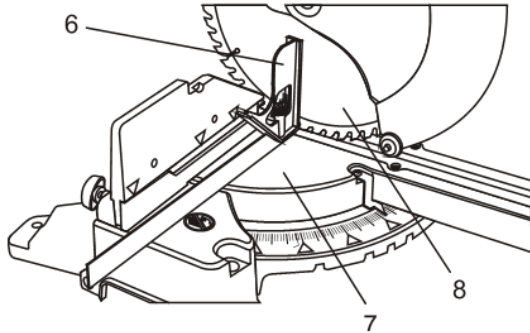

**Fig. 12**

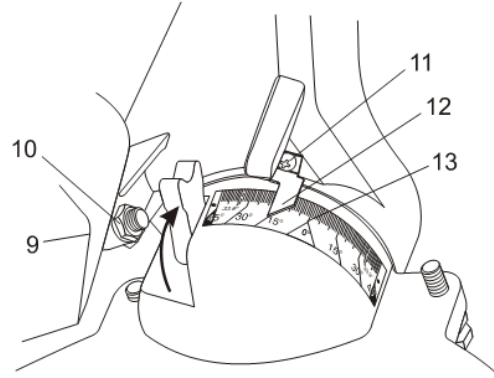
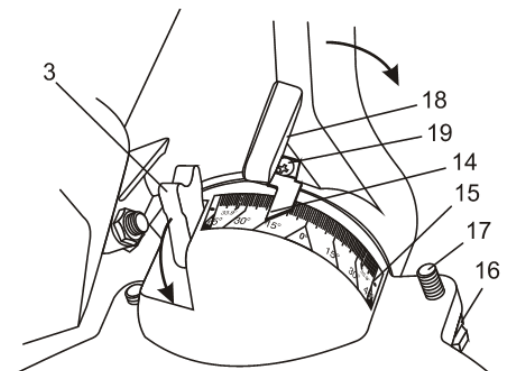

**Fig. 13**

## ADJUSTING THE LEFT & RIGHT 45° BEVEL ANGLE STOPS

The left & right 45° bevel angle stops must be adjusted to ensure accurate cuts at these most common angles. Adjust the right hand 45° bevel angle as follows:

1. Rotate the 0° bevel stop (3) toward you so it nests into the casting (Fig. 14).
2. Lift the bevel release to the vertical position.
3. Rotate the cutting head clockwise until the bevel indicator (14) is pointing directly to the 45° mark (15) on the bevel scale.
4. Check the blade angle to the base using a 45° protractor. If it is not at the correct angle, loosen the bevel release and re-adjust the angle to 45°.
5. Adjust the right hand 45° bevel stop by loosening the lock nut (16) and moving the cap screw (17) in or out as required then tighten the lock nut while holding the cap screw with a 13 mm wrench.



**Fig. 14**

### NOTES:

- a) You will require two 13 mm wrenches (not included) to adjust the lock nut and set screw.
  - b) Adjust the set screw so the bevel angle stop (18) contacts the set screw when the blade is at exactly 45° to the base.
6. If the 45° bevel pointer is not aligned directly with the 45° line on the scale, use a #2  $\oplus$  screwdriver (not included) to loosen the pointer screw (19). Then align the pointer with the 45° line on the scale and tighten the screw to hold the pointer firmly in place.
7. Adjust the left hand 45° bevel angle stop in exactly the same way as described for the right hand 45° bevel angle above.

## ADJUSTING DEPTH STOPS

The depth stops are designed to control the depth at which the blade will stop. The depth stop system is designed to easily switch between 0° and 45° bevel cut depths.

**⚠ WARNING:** When setting the depth stops, make sure the blade does not touch either the sides of the kerf slot or the bottom of the kerf slot. Failure to set the depth stops correctly could result in serious injury and damage to the mitre saw.

## Setting the 0° depth stop

1. Set the bevel angle at 0°.
2. Push the 45° pivoting stop (3) toward the cutting head so the slot (4) aligns with the hole in the casting (Fig. 15).
3. Loosen the 0° depth stop lock nut (1). Use a 10 mm wrench (not included) to turn the lock nut counter clockwise.
4. Back out the 0° depth stop screw (2) until it no longer extends below the threaded casting. Use a 5 mm hex key (not included).
5. Carefully lower the cutting head as far as it will go without forcing it.
6. While holding the cutting head down, turn the 0° depth stop screw clockwise until it lifts the blade 1/8".
7. Raise the cutting head and tighten the lock nut while holding the depth stop screw with the 5 mm hex key.

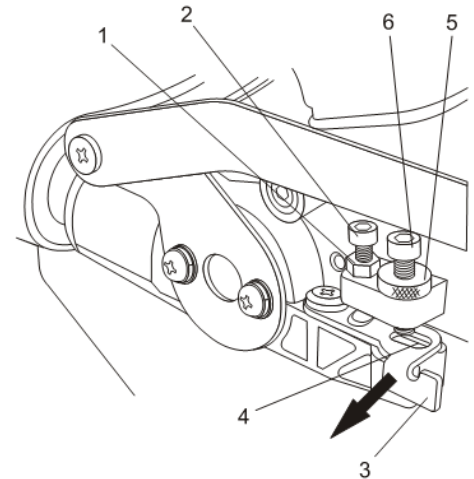

Fig. 15

## Setting the 45° depth stop

1. Set the bevel angle at 45°.
2. Pull the 45° pivoting stop (3) outward so the slot (4) aligns with the hole in the casting.
3. Loosen the 45° depth stop lock nut (5). Use pliers to turn it counter clockwise if it is too tight to be turned by hand.
4. Back out the 45° depth stop screw (6) until it no longer extends below the threaded casting. Use a 5 mm hex key (provided).
5. Carefully lower the cutting head as far as it will go without forcing it.

**NOTE:** Make sure the blade does not touch either the kerf slot or the bottom of the kerf while it is being lowered toward the base.

6. While holding the cutting head down, turn the 45° depth stop screw clockwise until it lifts the blade 1/8".
7. Raise the cutting head and tighten the lock nut while holding the depth stop screw with the 5 mm hex key.

## ADJUSTING SLIDER FRICTION KNOB

The slider friction knob has two functions. The first function is to prevent the cutting head from sliding in and out during transportation of the tool. The second function is to offer minor resistance when the cutting head is being moved in and out during the cutting process.

1. To lock the slider, turn the slider locking knob (1) clockwise until the cutting head is locked into the rear most position (Fig. 16).
2. To set the slider knob for operating the tool, turn the slider knob counter clockwise until the slider moves freely in and out but with enough friction to prevent sudden movements of the cutting head.

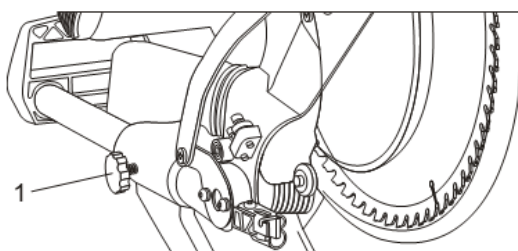

Fig. 16

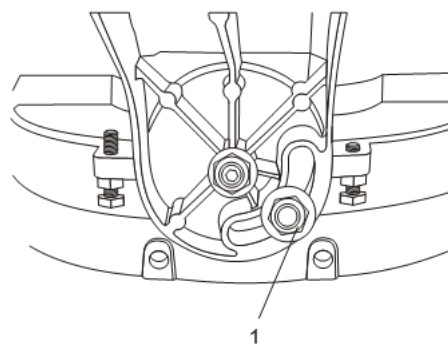

Fig. 17

## ADJUSTING BEVEL FRICTION

The bevel friction can be adjusted to make the cutting head easier or harder to move from side to side. To reduce the friction, turn the friction lock nut (1) counter clockwise (Fig. 17). To increase the friction, turn the friction lock nut clockwise.

**NOTE:** Use a 17 mm wrench (not included) to turn the friction lock nut.

## ADJUSTING THE BEVEL ANGLE FENCE EXTENDERS

**⚠ WARNING:** The bevel angle fence extenders **MUST** be adjusted to suit the BEVEL angle. If they are not adjusted properly, the fence will not function well and the cutting head could be damaged.

1. Loosen the fence extender locking knob (1) on the side to which the cutting head is tilted (Fig. 18).

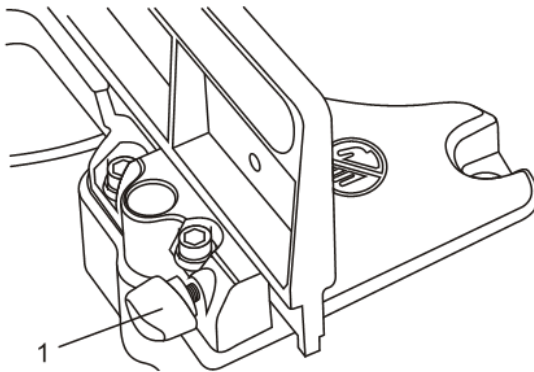

Fig. 18

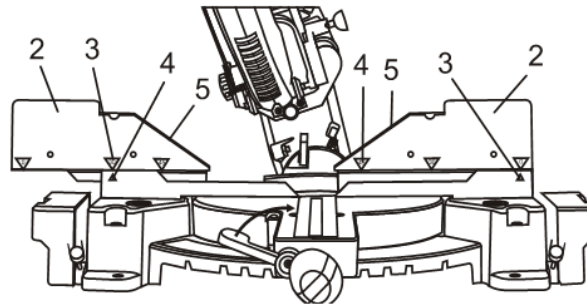

Fig. 19

2. Slide the fence extender (2) outward until the bevel appropriate angle (3) is aligned with the indexing mark (4) on the fence (Fig. 19).

### NOTES:

- a) Make sure the fence extender is slid **AT LEAST** to the bevel angle selected.
- b) There is a fence extender on each end of the fence. Make sure to adjust the left extender when the cutting head is tilted toward the left, etc.

3. Retighten the fence extender locking knob when the fence extender is set in the correct position.

## ADJUSTING THE LASER

It is important to ensure the laser beam is properly aligned with the saw blade. The procedure for aligning the laser is shown on the following page in the "OPERATING THE MITRE SAW" section of this manual.

## OPERATING THE MITRE SAW

### SWITCHES & POWER INDICATOR LIGHT

The switches and power indicator light are all contained within the main handle (1) of the mitre saw (Fig. 20). The description of how each element functions is described in the following paragraphs.

#### POWER INDICATOR LIGHT

The power indicator (2) will turn ON as soon as the plug is connected to a "live" power source. If the light does not turn ON, the power source is not "live".

#### LASER & WORKLIGHT ON/OFF SWITCH

The laser and worklight are turned ON and OFF with the same switch (3). To turn the switch ON, press the front edge of the switch. To turn the switch OFF, press the rear edge of the switch.

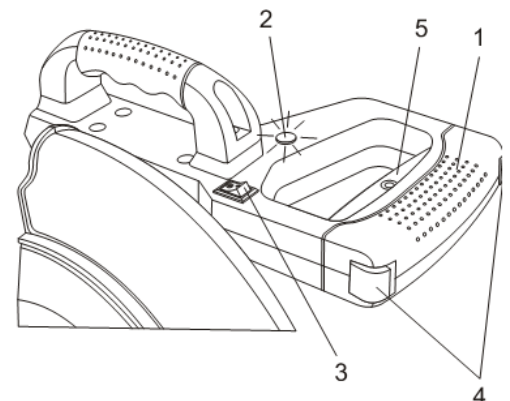

Fig. 20

**!** **WARNING:** Never stare directly at the laser beam. It can severely damage your eyes.

## LOCK-OFF SWITCHES

This tool is equipped with two lock-off switches (4) to prevent unintentional starting. Two lock-off switches are supplied to accommodate both right and left hand operation of the tool. ONE of these lock-off switches must be pressed and held before the tool will start.

## TRIGGER SWITCH

To turn the tool ON, press and hold one of the lock-off switches, then squeeze the trigger switch (5). Once the tool starts, you can release the lock-off switch while continuing to squeeze the trigger switch. To turn the tool OFF, release the trigger switch.

**NOTE:** Once the trigger switch has been released, the tool cannot be restarted without pressing and holding a lock-off switch before squeezing the trigger switch.

## BODY & HAND POSITION DURING CUTTING

**!** **WARNING:** Never cut small workpieces that are too small to be safely held by hand. Always secure small workpieces to the base using the hold-down clamp supplied with the tool (Fig. 7). Never cross your arms. Always place your hands AT LEAST 4" from the blade.

- Proper positioning of your body and hands will make cutting easier and safer. Keep your face and body to one side of the blade, out of line with a possible debris throwback (Fig. 21).
- Do not overreach; keep good footing and balance. Place your hands at least 4" from the blade. Hold the workpiece firmly against the fence and keep your hands in position until the trigger has been released and the blade has completely stopped.
- Before making a cut, either make a "dry run" with the power off to determine the path of the blade or turn on the laser and check the path of the blade against the laser.

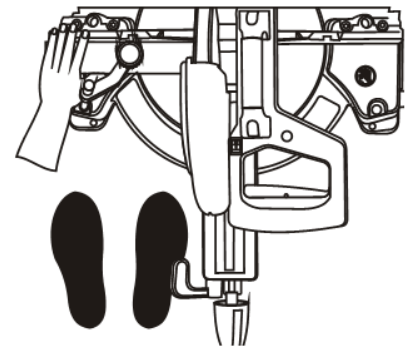

Fig. 21

## USING THE WORKPIECE SUPPORT

When cutting longer workpieces, always use the base extension supports (1) for more accurate cutting and to help prevent the long workpiece from sagging (Fig. 22).

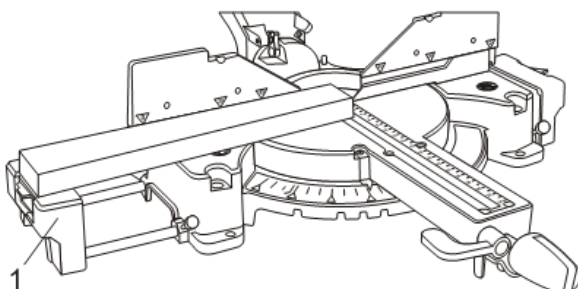

Fig. 22

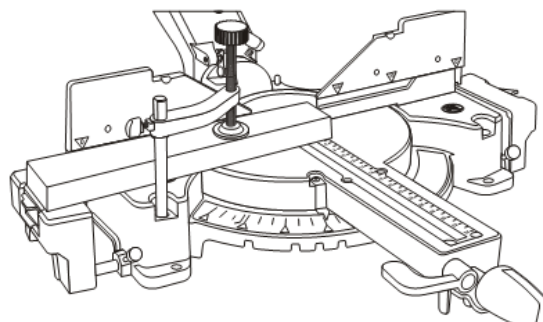

Fig. 23

## USING THE HOLD-DOWN CLAMP

The hold-down clamp should be used whenever possible to firmly anchor the workpiece to the base (Fig. 23). Use the clamp to hold the longer portion of the workpiece. Using the hold-down clamp will promote more accurate cuts.

**WARNING:**  
For safety reasons, the operator must read the sections of this Owner's Manual entitled "GENERAL SAFETY WARNINGS", "POWER TOOL SAFETY", "SPECIFIC SAFETY RULES", "EXTENSION CORD SAFETY" and "SYMBOLS" before using this mitre saw.

Verify the following every time the mitre saw is used:

1. The blade is properly installed.
2. The blade is sharp and in good condition.
3. The mitre angle lock and bevel angle lock are tight and properly holding the cutting head in the desired position.
4. The workpiece is properly secured.
5. Safety glasses and hearing protection are being worn.

Failure to observe these safety rules will significantly increase the risk of injury.

## MAKING A TEST CUT

It is important to make a test cut on a scrap workpiece each time one or more settings on the saw have been changed. It is particularly important to make a test cut at 0° mitre and 0° bevel settings to verify that the saw will accurately cut at right angles and that the laser is properly set.

1. Clamp a scrap workpiece such as a 2x4 (1) onto the base, leaving approximately 2" to be cut off (Fig. 24).
2. Grasp the main handle and lift the cutting head to its highest point.
3. Turn the laser/worklight switch ON.

**NOTE:** The laser cutting line (2) will show on the 2x4.

4. Grasp the main handle and turn the saw ON.
5. Pull the main handle toward you as far as it will go, then pull the handle downward, and finally push it away from you while cutting the 2x4.

### NOTES:

- a) Follow the cutting head movement pattern (3).
- b) Only cut part way through the workpiece Fig. 25. You will need the saw cut for adjusting the laser.

6. When the partial cut is complete, release the trigger switch and do NOT move the cutting head until the blade comes to a complete stop.
7. Lift the main handle up to its maximum height.

**NOTE:** Do not move the clamped workpiece at this point, as it must remain in position to adjust the laser.

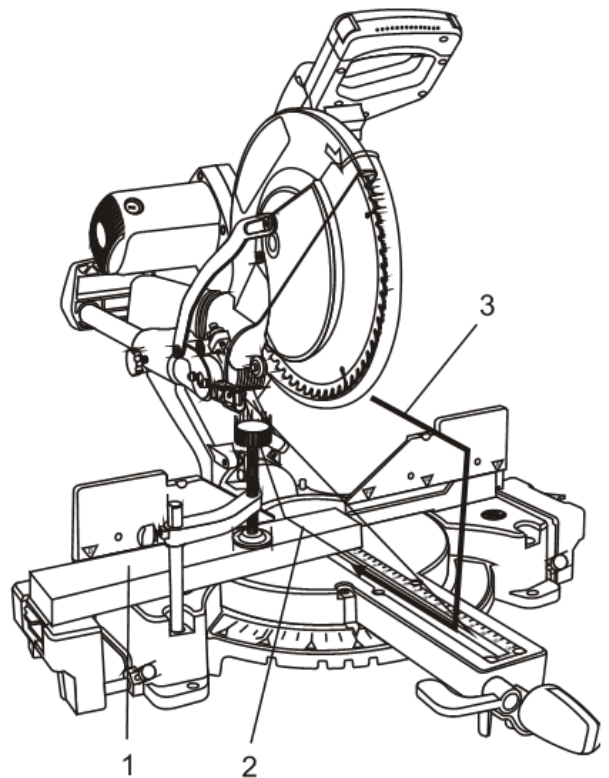
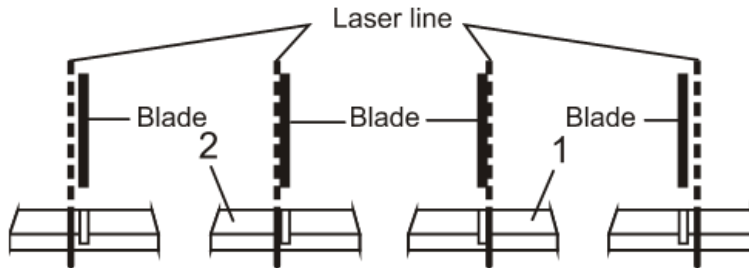

Fig. 24

## LASER LINE ADJUSTMENT

Now that you have made a test cut, the laser will have to be aligned so it is immediately beside the cutting line (Fig. 25). Adjustment will vary depending upon whether the "good piece" is to the left or right hand side of the blade. For purposes of illustration, the "good piece" is to the right hand side of the workpiece (1) as is usually the case for right handed operators. Left handed operators will normally leave the "good piece" to the left hand side of the workpiece (2).

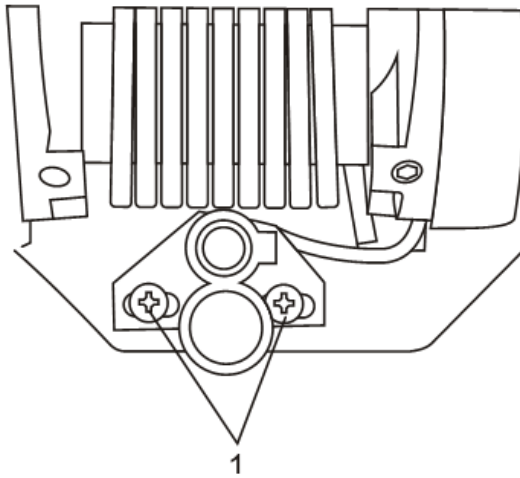

**Fig. 25**



**WARNING: Never stare directly at the laser beam. It can severely damage your eyes.**

To adjust the laser line, use a #2  $\oplus$  screwdriver (not included) to loosen the two laser mounting screws (1) (Fig. 26). Slide the laser bracket to the left or right until the laser beam just clears the right hand side of the blade and is completely on the "good piece". This will align the blade so it will cut the workpiece on the left hand side of the laser beam. Tighten the two laser mounting screws and make another test cut to verify the laser alignment.



**Fig. 26**

To make a mitre cut at another angle, loosen the mitre locking knob, rotate the base to the correct mitre angle and lock the mitre adjusting knob.

## USING THE REPETITIVE CUT STOP

The base extensions (1) have built-in stops for use when making repetitive cuts of the same length (Fig. 27). To use the stop, simply rotate the stop (2) 90° so it provides a positive stop for the workpiece.

**NOTE:** To adjust the length of the piece to be cut, simply loosen the base extension locking screw and slide the base extension in or out until the cut stop is the correct distance from the blade. The cut stop can be used for repetitive cut lengths between 6" & 12".

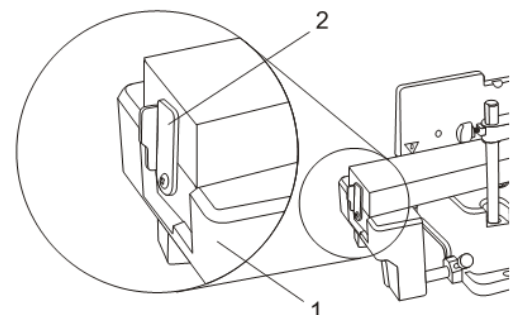

**Fig. 27**

## CLEANING THE DUST BAG

The dust collection bag located behind the motor assembly must be cleaned regularly to maintain its efficiency.

1. To remove the dust bag, squeeze the two wire clamp wings (1) together and slide the dust bag off the dust chute (Fig. 28).
2. Hold the open end of the dust bag over a trash can and shake all the sawdust from the bag.
3. Reinstall the dust bag on the dust chute by reversing the removal instructions in paragraph #1 above.

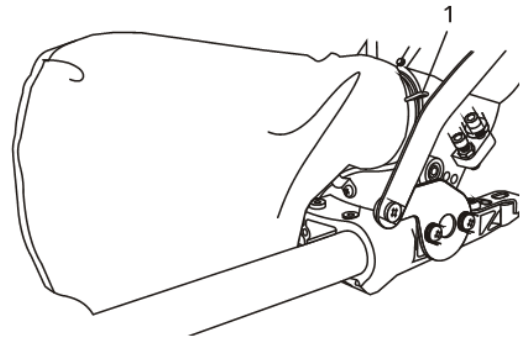

Fig. 28

## CUTTING A WARPED WORKPIECE

**WARNING:** Cutting a warped workpiece as illustrated below may result in the blade to bind. This could cause the workpiece to jump unexpectedly and cause serious injury.

Always place the convex side of the warped workpiece against the fence (Fig. 29).

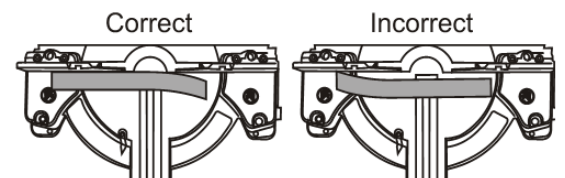

Fig. 29

## BEVEL CUTTING

1. Adjust the fence extender (1) as outlined in Fig. 18 & 19)
2. Loosen the bevel locking lever (2) (Fig. 30).
3. Rotate the cutting head (3) to the desirable bevel angle.
4. Tighten the bevel locking lever.
5. Hold the workpiece firmly against the left hand side of the fence, stand to the left side of the mitre saw and make the cut.

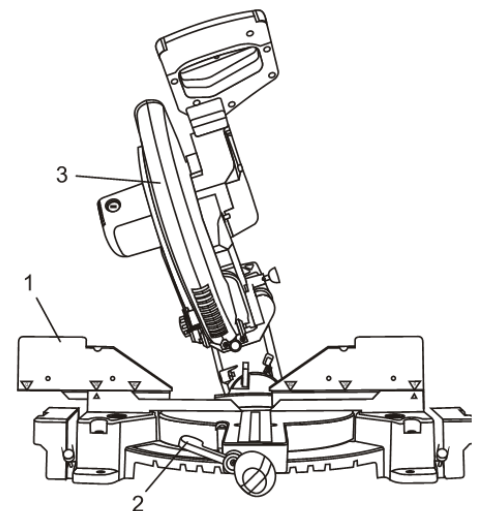

Fig. 30

## COMPOUND CUTTING

Compound cutting is simply making a mitre cut and a bevel cut at the same time.

To perform a compound cut:

1. Adjust the fence extender to the appropriate angle
2. Loosen the bevel locking lever, move the cutting head to the appropriate angle and lock the bevel locking lever.
3. Loosen the mitre locking knob, position the base at the appropriate angle and lock the mitre locking knob.
4. While firmly holding the workpiece against the base and the fence, turn the saw ON and make the cut.

**NOTE:** When making a compound cut, you should move your feet and body to keep yourself in line with the handle as you make the cut.

## CUTTING BASE MOLDING

Base moldings and trims can be cut on a compound mitre saw. The method depends upon the type of molding, its characteristics and its applications (Fig. 31).

1. Use vise clamps, hold-down or C-clamps whenever possible. Place tape on the area being clamped to avoid marking the finish surface of the moulding.
2. Tape the area being cut to avoid splintering, and mark the cut line on the tape.
3. Perform practice cuts on scrap pieces before cutting the final molding.

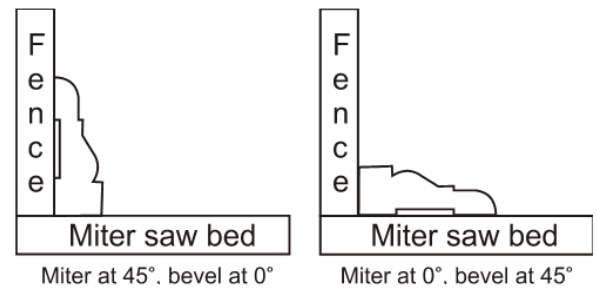

**Fig. 31**

**NOTE:** Splintering may be caused due to the thinness of the moulding or use of the wrong type of saw blade.

## CUTTING CROWN MOLDING

Crown molding must be compound mitred with extreme accuracy. The two surfaces on the crown molding must fit the wall or ceiling, and each other. The two cut surfaces of the mitred molding must add to a 90° angle. Most crown moulding has a top angle of 52° that fits flat on the ceiling, and a bottom rear angle of 38° that fits flat against the wall.

Crown molding is thin and splinters very easily. Crown moulding with widths less than 4½" should be with the edges resting on both the fence and the base. Crown mouldings with widths between 4½" and 10¼" should be cut with the back of the moulding lying flat on the base.

**NOTE:** Refer to the chart below that explains the correct angles for cutting the various elements of the crown moulding corners.

### CROWN MOLDING CUTS

MAX. SIZE 10¼"

52° CEILING  
38° WALL

ANGLES OF U.S. ST'D MOLDING

INSIDE CORNER (A, B)  
OUTSIDE CORNER (C, D)

### CROWN MOLDING CUTS

MAX. SIZE 4¼"

52° BOTTOM EDGE

TYPE OF CUT	MITER (TABLE) SETTING	BEVEL (TILT) SETTING	
<b>INSIDE CORNER</b>			
LEFT SIDE <b>A</b>	RIGHT 31.6°	33.9°	PLACE TOP EDGE OF MOLDING AGAINST FENCE - SAVE LEFT END OF CUT
RIGHT SIDE <b>B</b>	LEFT 31.6°	33.9°	PLACE BOTTOM EDGE OF MOLDING AGAINST FENCE - SAVE LEFT END OF CUT
<b>OUTSIDE CORNER</b>			
LEFT SIDE <b>C</b>	LEFT 31.6°	33.9°	PLACE BOTTOM EDGE OF MOLDING AGAINST FENCE - SAVE RIGHT END OF CUT
RIGHT SIDE <b>D</b>	RIGHT 31.6°	33.9°	PLACE TOP EDGE OF MOLDING AGAINST FENCE - SAVE RIGHT END OF CUT

ALL CUTS - PLACE BOTTOM EDGE AGAINST FENCE			
TYPE OF CUT	MITER (TABLE) SETTING	BEVEL (TILT) SETTING	
<b>INSIDE CORNER</b>			
LEFT SIDE <b>A</b>	RIGHT 45°	0°	SAVE RIGHT END OF CUT
RIGHT SIDE <b>B</b>	LEFT 45°	0°	SAVE LEFT END OF CUT
<b>OUTSIDE CORNER</b>			
LEFT SIDE <b>C</b>	LEFT 45°	0°	SAVE RIGHT END OF CUT
RIGHT SIDE <b>D</b>	RIGHT 45°	0°	SAVE LEFT END OF CUT

## MAINTENANCE

### GENERAL

**⚠ WARNING:** When servicing the mitre saw, always check to make sure the switch is **OFF** and the plug is removed from the power source. Accidental starting could cause serious injury to the operator.

### CHANGING THE BLADE

**⚠ WARNING:** Remove the plug from the power source and exercise extreme caution when working around or handling the blade.

1. Lift the cutting head up to its maximum height (Fig. 32).
2. Use a #2  $\oplus$  (not included) screwdriver and loosen the screw (1) in the secondary blade guard (2).
3. Slide the secondary blade guard upward to expose the blade screw (3).

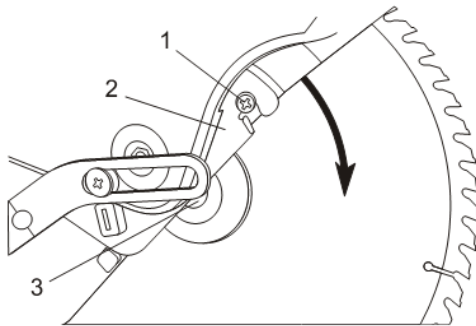

Fig. 32

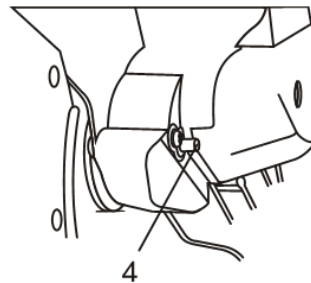

Fig. 33

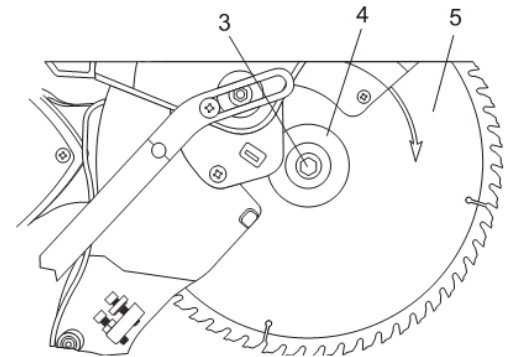

Fig. 34

4. Press the spindle lock (4) and carefully rotate the blade until the spindle lock engages with the blade and stops the blade from turning (Fig. 33).

**NOTE:** The spindle lock is located on the opposite side of the blade guard.

5. While holding the spindle lock inward to prevent the blade rotating, place the special blade screw wrench on the blade screw (3) and turn the screw **CLOCKWISE** to remove it from the arbor (Fig. 34).

#### NOTES:

- a) Be sure to turn the blade screw **CLOCKWISE**. It is a left hand thread.
- b) Place an old towel or other soft material under the blade to protect the sharp teeth when the blade comes off the arbor.

6. When the screw is removed from the arbor, remove the large flange washer (4) from the arbor and then remove the blade (5).

#### NOTES:

- a) Be careful when handling the blade. It will still be sharp and will cut you.
- b) Do not lose the small bushing that is inside the hole in the blade.

### REPLACING THE BLADE

To replace the blade, reverse the above procedure.

**⚠ WARNING:** Never use blades recommended for operation at less than 3800rpm.

1. Place the blade screw bushing (6) on the arbor (Fig. 35).
2. Place the blade (5) on the arbor.

### NOTES:

- a) Make sure the teeth on the bottom of the blade are pointing toward the rear of the saw.
- b) Make sure the blade hole fits over the blade screw bushing.

3. Place the large flange washer (4) on the arbor.

**NOTE:** Make sure the flat side of the large flange washer is facing the blade.

4. Thread the flanged blade screw (3) into the arbor.

### NOTES:

- a) Turn the blade screw counter clockwise to thread it into the arbor. The screw is a left hand thread.
- b) Make sure the large flange washer is properly installed on the arbor.

5. Lock the blade using the spindle lock and tighten the blade screw using the special blade screw wrench provided.

**NOTE:** Turn the blade by hand after the blade screw is tightened to make sure the blade does not wobble. If the blade wobbles, check to see if the large flange washer is properly fitted to the arbor and that the blade is not damaged.

6. Pull the secondary blade guard (2) down so the slot fits behind the head of the screw (1) (Fig. 32).
7. Tighten the secondary blade guard screw.

## REPLACING THE CARBON MOTOR BRUSHES

The carbon motor brushes will wear down and require replacing. The time intervals between replacements will vary depending upon the torques being achieved and the hours of use. It is recommended that the brushes be checked after each 10 hours of use. When the length of the carbon brush reaches 1/4", the brushes should be replaced.

**WARNING:** Unplug the tool from the power source.

1. Use a 1/4" slot screwdriver (not included) and remove one brush cap (1) (Fig. 36). Turn the brush cap counter clockwise to remove it from the motor housing.
2. Pull the spring & brush assembly (2) from the brush holder (3) in the motor housing (4).
3. Insert the new spring & brush assembly into the motor housing.
4. Compress the spring into the brush holder and thread the brush cap back into the motor housing.

**NOTE:** Make sure the brush cap threads are not cross-threaded.  
Do NOT over tighten.

Repeat steps 1 to 4 and replace the second carbon brush located on the opposite side of the motor housing.

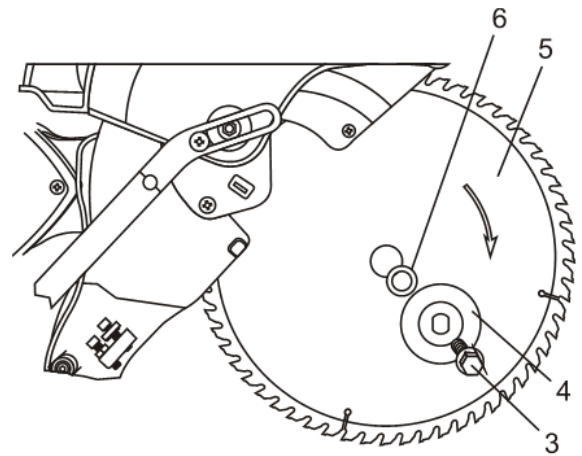

Fig. 35

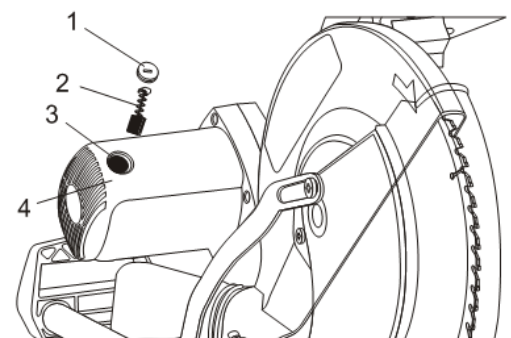

Fig. 36

## CLEANING THE MITRE SAW



**WARNING: Always wear safety goggles or safety glasses with side shields during all cutting operations. It is critical that you wear safety goggles or safety glasses with side shields and a dust mask while blowing dust out of the mitre saw with an air jet. Failure to take these safety precautions could result in permanent eye or lung damage.**

Empty the dust bag at regular intervals. If the dust bag gets too full, it will not be effective at collecting sawdust from the blade.

Periodically use an air jet or vacuum to remove the accumulated sawdust from around and under the mitre saw. Pay particular attention to removing the sawdust around and under the lower blade guard. Accumulated sawdust may interfere with proper operation of the automatic lower blade guard.

When cleaning the mitre saw, carefully remove sawdust from around the laser and worklight module with a soft dry brush or cloth. Be careful not to change the alignment of the laser module as this will cause incorrect cuts and require realignment of the laser module.

DO NOT use solvents when cleaning plastic parts. Plastics are susceptible to damage from various types of commercial solvents and may be damaged by their use. Use a clean cloth to remove dirt, dust, oil, grease etc.



**WARNING: Do not allow brake fluids, gasoline, petroleum-based products, penetrating oils, etc. to come into contact with plastic parts. They contain chemicals that can damage, weaken or destroy plastic.**

## GENERAL MAINTENANCE

Check the lower blade guard each time the mitre saw is used. The guard must be free of sawdust and functioning properly before the saw is turned ON.

DO NOT abuse the mitre saw. Abusive practices can damage the tool and the workpiece and cause possible serious injury to the operator.



**WARNING: DO NOT attempt to modify the mitre saw or create accessories. Any such alteration or modification is misuse and could result in a hazardous condition leading to possible serious injury. It will also void the warranty.**



**WARNING: When servicing this mitre saw, use only identical replacement parts. The use of any other parts may create a hazard or cause product damage.**

## LUBRICATION

All of the bearings in this tool are lubricated with a sufficient amount of high-grade lubricant for the life of the unit under normal conditions. Therefore, no further lubrication is required.

## EXPLODED VIEW

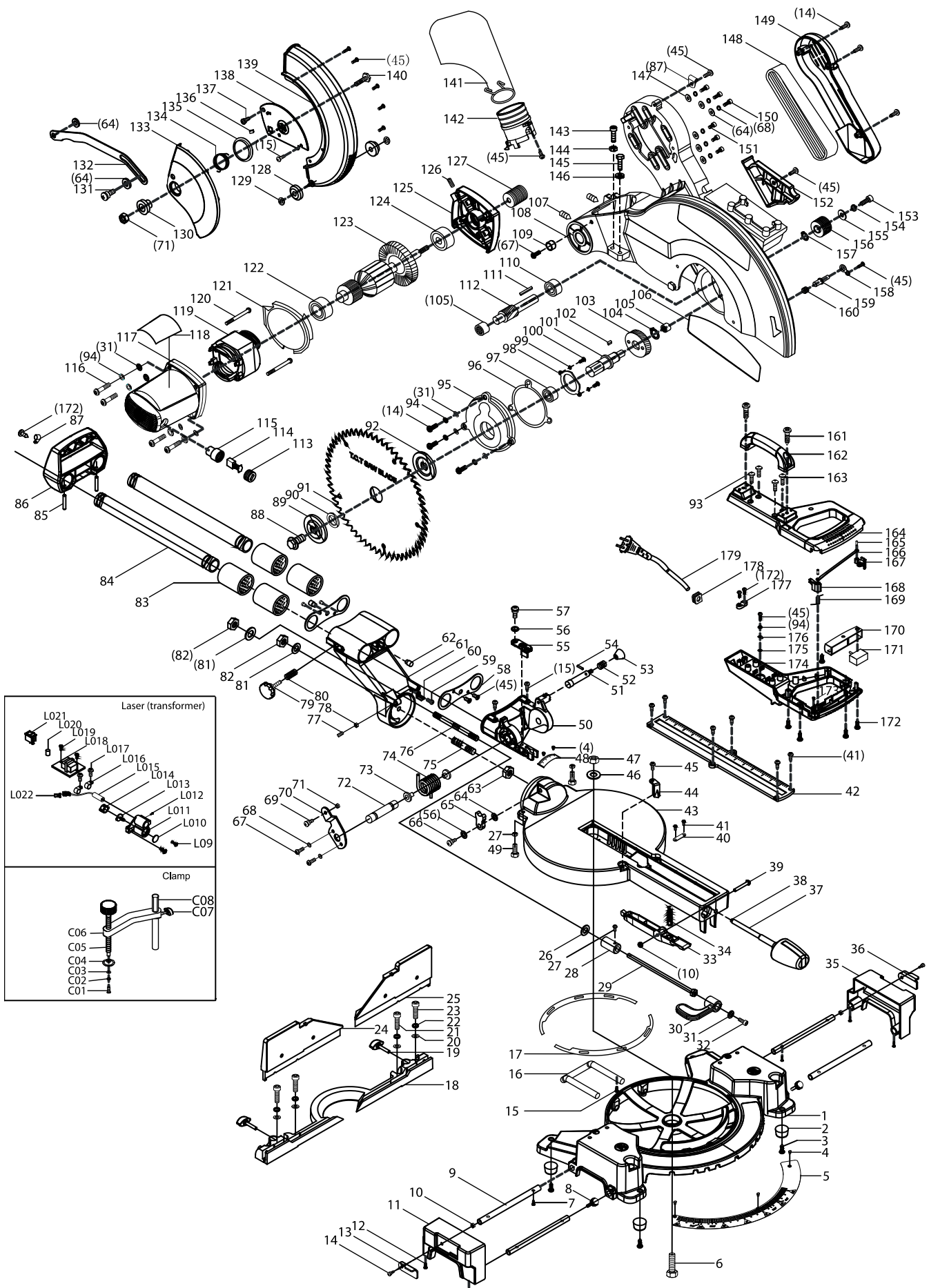

## PARTS LIST

**WARNING!** When servicing, use only original equipment replacement parts. The use of any other parts may create a safety hazard or cause damage to the tool. Any attempt to repair or replace electrical parts on this tool may create a safety hazard unless repairs are performed by a qualified technician. For more information, call the Toll-free Helpline, at 1-866-349-8665.

Key#	Part #	Part Name	Qty
1	1347-006-001	Base	1
2	1347-006-002	Foot pad	4
3	1347-006-003	ST3.9×8 Cross pan head tapping screw	4
4	1347-006-004	Ø2×4 Rivet	5
5	1347-006-005	Scale indicator	1
6	1347-006-006	M8×55 Hexagon bolt	1
7	1347-006-007	M5×6 Cross pan head screw	2
8	1347-006-008	M5×25 Bed extension locking screw	2
9	1347-006-009	Extension bar	4
10	1347-006-010	M5 Lock nut	3
11	1347-006-011	Bed extension block (left)	1
12	1347-006-012	M5×8 Cross pan head screw	4
13	1347-006-013	Repetitive cutting stop (left)	1
14	1347-006-014	M5×20 screw	9
15	1347-006-015	M6×10 screw	4
16	1347-006-016	Rear stabilizer bar	1
17	1347-006-017	Steel sheet	2
18	1347-006-018	Fence	1
19	1347-006-019	M6×32 Thumb screw	2
20	1347-006-020	Ø8 Flat washer	4
21	1347-006-021	M8×25 Screw	2
22	1347-006-022	Ø8 Spring washer	4
23	1347-006-023	M8×35 Screw	2
24	1347-006-024	Movable fence (left)	1
25	1347-006-025	Movable fence (right)	1
26	1347-006-026	Ø12 Flat washer	1
27	1347-006-027	M8 Nut	2
28	1347-006-028	Locknut	1
29	1347-006-029	Bevel locking bar	1
30	1347-006-030	Bevel locking handle	1
31	1347-006-031	Ø5 flat washer	8
32	1347-006-032	M5×10 screw	1
33	1347-006-033	Mitre positioning handle	1
34	1347-006-034	Pressure spring	1
35	1347-006-035	Bed extension block (right)	1
36	1347-006-036	Repetitive cutting stop (right)	1
37	1347-006-037	Mitre adjusting knob assembly	1
38	1347-006-038	Cushion	1
39	1347-006-039	M5×35 Screw	1
40	1347-006-040	Mitre adjusting rod retainer	1

Key#	Part #	Part Name	Qty
41	1347-006-041	M4×8 Cross pan head screw	8
42	1347-006-042	Table insert	1
43	1347-006-043	Rotary table	1
44	1347-006-044	Indicator needle	1
45	1347-006-045	M5×10 Screw	15
46	1347-006-046	Ø8 Flat washer	1
47	1347-006-047	M8 Locknut	2
48	1347-006-048	Scale indicator for bevel sawing	1
49	1347-006-049	M8×20 Screw	2
50	1347-006-050	Bracket	1
51	1347-006-051	Lock pin	1
52	1347-006-052	Lock spring	1
53	1347-006-053	Lock cap	1
54	1347-006-054	Ø3×16 cross pin	1
55	1347-006-055	Height limitre	1
56	1347-006-056	Ø8 Wave washer	2
57	1347-006-057	Round head screw with shoulder	1
58	1347-006-058	Bearing pressure board	2
59	1347-006-059	M4×10 Cross pan head screw	1
60	1347-006-060	Bevel sawing pin	1
61	1347-006-061	Bracket	1
62	1347-006-062	Positioning pin	2
63	1347-006-063	M10 Hex nut	1
64	1347-006-064	Ø6 Flat washer	8
65	1347-006-065	Angle adjusting block	1
66	1347-006-066	M6×16 Screw	1
67	1347-006-067	M6×14 Cross pan head screw	3
68	1347-006-068	Ø6 Spring washer	8
69	1347-006-069	M6×10 Screw	1
70	1347-006-070	Connecting rod supporter	1
71	1347-006-071	M6 Locknut	2
72	1347-006-072	Pin	1
73	1347-006-073	Spring bushing	2
74	1347-006-074	Large torque spring	1
75	1347-006-075	M10×86 Double head bolt	1
76	1347-006-076	Screw rod	1
77	1347-006-077	M8×25 Bolt	1
78	1347-006-078	M8 Nut	1
79	1347-006-079	M6×25 Slider tension knob	1
80	1347-006-080	Small spring	1
81	1347-006-081	Ø10 Flat washer	2
82	1347-006-082	M10 Locknut	2
83	1347-006-083	Ø45×Ø30×50 slide bearing	4
84	1347-006-084	Extension bar	2
85	1347-006-085	Ø5×44 Flexible column pin	2

Key#	Part #	Part Name	Qty
86	1347-006-086	Rear pull rod cover	1
87	1347-006-087	Clip	2
88	1347-006-088	M8×18 Hexagon head bolt	1
89	1347-006-089	Outside flange	1
90	1347-006-090	Blade position ring	1
91	1347-006-091	Saw blade (12")	1
92	1347-006-092	Inner flange	1
93	1347-006-093	M5×40 Cross pan head screw	2
94	1347-006-094	Ø5 Spring washer	8
95	1347-006-095	Front cover	1
96	1347-006-096	Paper gasket (oil seal)	1
97	1347-006-097	6003 Bearing	1
98	1347-006-098	Bearing retainer	1
99	1347-006-099	Ø4 Spring washer	2
100	1347-006-100	M4×12 Cross pan head screw	2
101	1347-006-101	Output shaft	1
102	1347-006-102	Parallel key 4×4×8	1
103	1347-006-103	Big gear	1
104	1347-006-104	Ø15 Circlip for shaft	1
105	1347-006-105	Needle bearing HK1010	2
106	1347-006-106	Label	1
107	1347-006-107	M6×10 Allen set screw	2
108	1347-006-108	Fixed blade guard	1
109	1347-006-109	Fixed blade guard positioning pin	1
110	1347-006-110	6001 Bearing	1
111	1347-006-111	Key 4×4×20	1
112	1347-006-112	Gear shaft	1
113	1347-006-113	Brush cover	2
114	1347-006-114	carbon brush	2
115	1347-006-115	Brush holder	2
116	1347-006-116	M5×35 Cross pan head screw	4
117	1347-006-117	Housing	1
118	1347-006-118	Label	1
119	1347-006-119	Stator	1
120	1347-006-120	ST4.8×65 Cross pan head tapping screw	2
121	1347-006-121	Air deflector	1
122	1347-006-122	6000 Bearing	1
123	1347-006-123	Rotor	1
124	1347-006-124	6002 Bearing	1
125	1347-006-125	Middle cover	1
126	1347-006-126	M8×25 Hexagon socket screw	1
127	1347-006-127	Drive pully	1
128	1347-006-128	Transparent guard wheel	2
129	1347-006-129	Ø5 Circlip for shaft	2

Key#	Part #	Part Name	Qty
130	1347-006-130	Transparent guard washer (small)	1
131	1347-006-131	Screw	1
132	1347-006-132	Connecting rod	1
133	1347-006-133	Transparent guard reinforcing plate	1
134	1347-006-134	Transparent guard coil spring	1
135	1347-006-135	Transparent guard (big)	1
136	1347-006-136	Rubber stop	1
137	1347-006-137	M6×7 Flat head screw	1
138	1347-006-138	Spring board of transparent guard	1
139	1347-006-139	Transparent guard	1
140	1347-006-140	M6×14 Hexagon head bolt	1
141	1347-006-141	Dust collection bag	1
142	1347-006-142	Dust outlet tube	1
143	1347-006-143	M6×25 Screw	2
144	1347-006-144	M6 Nut	2
145	1347-006-145	M6×35 Hexagon screw	1
146	1347-006-146	Depth adjustment nut	1
147	1347-006-147	Ø6 Flat washer	1
148	1347-006-148	Belt (10PJ560)	1
149	1347-006-149	Belt cover	1
150	1347-006-150	M6×20 Hexagon socket screw	3
151	1347-006-151	M6×16 Hexagon socket screw	3
152	1347-006-152	Cover board	1
153	1347-006-153	M6×16 Hexagon socket screw	1
154	1347-006-154	Ø6 Spring washer	1
155	1347-006-155	Ø6 Flat washer	1
156	1347-006-156	Driven pulley	1
157	1347-006-157	Ø28 Circlip for hole	1
158	1347-006-158	Cover board of lock pin	1
159	1347-006-159	Lock pin	1
160	1347-006-160	Taper spring	1
161	1347-006-161	ST6×18 Cross pan head tapping screw	2
162	1347-006-162	Handle	1
163	1347-006-163	M5×50 Cross pan head screw	2
164	1347-006-164	Handle cover	1
165	1347-006-165	Fixed pin	2
166	1347-006-166	Connection sheet	1
167	1347-006-167	Lock-off button (right)	1
168	1347-006-168	Lock-off button (left)	1
169	1347-006-169	Torque spring	1
170	1347-006-170	Trigger	1
171	1347-006-171	Switch (FA2-10/1W)	1
172	1347-006-172	ST3.9×14 Cross pan head tapping screw	8

Key#	Part #	Part Name	Qty
173	1347-006-173	ST3.9×10 Cross pan head tapping screw	1
174	1347-006-174	Handle	1
175	1347-006-175	Ø5 Wave washer	1
176	1347-006-176	Connection button	1
177	1347-006-177	Cord pressure board	1
178	1347-006-178	Cord guard	1
179	1347-006-179	Power cord & plug	1
C01	1347-006-C01	M5×12 Cross pan head bolt	1
C02	1347-006- C02	Ø5 Spring washer	1
C03	1347-006- C03	Ø6 Flat washer	1
C04	1347-006- C04	Clamp platen	1
C05	1347-006- C05	Clamp screw	1
C06	1347-006- C06	Horizontal connection rod	1
C07	1347-006- C07	M6×20 Thumb screw	1
C08	1347-006- C08	Positioning rod	1
L009	1347-006- L009	M4×8 Cross pan head screw	2
L010	1347-006- L010	LED Front cover	1
L011	1347-006- L011	Laser base	1
L012	1347-006- L012	M4×4 Hexagon socket bolt	1
L013	1347-006- L013	LED	1
L014	1347-006- L014	LED Lamp rear cover	1
L015	1347-006- L015	Laser	1
L016	1347-006- L016	Cord clamp	2
L017	1347-006- L017	M4×6 Cross pan head screw	2
L018	1347-006- L018	Transformer(110V)	1
L019	1347-006- L019	ST2.9×6 Cross pan head tapping screw	2
L020	1347-006- L020	Indicator light	1
L021	1347-006- L021	Switch	1
L022	1347-006- L020	Terminal	1

## **WARRANTY**

### **BENCHMARK 12" COMPOUND SLIDING MITRE SAW**

If this Benchmark tool fails due to a defect in material or workmanship within five years from the date of purchase, return it to any Home Hardware store with the original bill of sale for exchange. 3-year warranty for the battery and charger. This warranty does not include expendable parts including but not limited to blades, brushes, belts, light bulbs. This warranty covers defects in material or workmanship only. It does not cover normal wear and tear, failure due to abuse/misuse, or defects caused by careless or accidental mishandling. If this Benchmark product is used for commercial or rental purposes, this warranty does not apply.

# 12" SLIDING COMPOUND MITRE SAW



**BENCHMARK™**

**BENCHMARK TOOLS CANADA**

ST. JACOBS, ONTARIO N0B 2N0

© 2022 Home Hardware Stores Limited

**CUSTOMER SERVICE/TECH SUPPORT**

1-866-349-8665

**1347-006**

Made in China



\* This Benchmark™ product carries a five (5) year LIMITED warranty against defects in workmanship and materials. The charger and batteries carry a three (3) year LIMITED warranty. See Owner's Manual for full details.



**READ ALL INSTRUCTIONS BEFORE FIRST USE. KEEP THIS MANUAL FOR FUTURE REFERENCE. KEEP AWAY FROM CHILDREN.**



**WEAR CSA APPROVED  
EYE PROTECTION**



**WEAR EAR  
PROTECTION**



**WEAR A  
FACE MASK**