

Radley®

9.5A, 7 1/4"
Sliding Compound

Miter Saw



3 Year
limited
warranty

Owner's
Manual



READ ALL INSTRUCTIONS BEFORE FIRST USE.
KEEP THIS MANUAL FOR FUTURE REFERENCE.
KEEP AWAY FROM CHILDREN.

PRODUCT SPECIFICATIONS

7 1/4" SLIDING COMPOUND MITRE SAW	
Motor	120V AC, 60 Hz, 9.5A
Speed	5000 RPM (no load)
Blade	7 1/4" /18.4 cm 24-tooth carbide-tipped
Arbor Size	5/8" /15.9 mm
Cutting Capacity	2 x 8 3/4" /5.1 x 21 cm crosscut at 0° mitre, 0° bevel 2 x 6" /5.1 x 15.2 cm mitre cut at 45° mitre, 0° bevel 1 1/2 x 6" /3.8 x 15.2 cm) compound cut at 45° mitre, 45° bevel 1 1/2 x 8 3/4" /3.8 x 21 cm cross cut at 45° bevel, left
Weight	22.7lbs/10.3kgs

Need Assistance?

Call us on our toll free customer support line:

1-866-349-8665 (Monday through Friday, 9am – 5pm Eastern Standard Time)

- Technical questions
- Replacement parts
- Parts missing from package

TABLE OF CONTENTS

Specifications	1
Table of contents	2
Safety guidelines	3-9
Double insulated tools/Electrical safety	4-5
Minimum gauge for cord sets	5
Safety rules for laser lights	6
Specific safety rules for mitre saws	7-9
Glossary of woodworking terms	9
Symbols	10
Know your Sliding Compound Mitre Saw	11
Assembly and operating	12-26
Removing and installing the blade	12-13
Installing the dust bag/Mitre scale/How to adjust mitre angles	14
Mitre angle pointer adjustment	15
Adjusting fence squareness	15
Bevel stop adjustment	15
90°/0° Bevel adjustment	15-16
90° Bevel pointer adjustment	16
45° Bevel adjustment	16
Maximum cutting depth	16-17
Unlocking and locking the cutting head	18
Unlocking the slide carriage	18
Bench mounting	19
Installing the work clamp	19
On/off trigger switch	19
On/off laser	19
Dry run	19
Mitre cut/Bevel cut/Compound cut	20
Sliding carriage system	21
Slide cutting wide boards	21
Setting cutting depth/Cutting grooves	22
Cutting warped material/Auxiliary wood fence/Cutting base moulding	23
Cutting crown moulding/ Bevel/Mitre settings	24
Sawdust/Lower blade guard/Replacing carbon brushes	25
Lubrication	26
Troubleshooting	27
Exploded view	28
Parts list	29-32
Warranty	33

SAFETY GUIDELINES

- **Keep guards in place and in working order.**
- **Remove adjusting keys and wrenches.** Form habit of checking to see that keys and adjusting wrenches are removed from tool before turning it on.
- **Keep work area clean.** Cluttered areas and benches invite injuries.
- **Don't use in dangerous environment.** Don't use power tools in damp or wet locations, or expose them to rain or snow. Keep work area well lighted.
- **Keep children away.** All visitors should be kept at a safe distance from work area.
- **Make workshop childproof** with padlocks, master switches, or by removing starter keys.
- **Don't force the tool.** It will do the job better and safer at the rate for which it was designed.
- **Use the right tool.** Don't force tool or attachment to do a job for which it was not designed.
- **Wear proper apparel.** Do not wear loose clothing, gloves, neckties, rings, bracelets, or other jewellery which may get caught in moving parts. Non-slip footwear is recommended. Wear protective hair covering to contain long hair.
- **Always use safety glasses.** Also use face or dust mask if cutting operation is dusty. Everyday eyeglasses only have impact-resistant lenses, they are not safety glasses.
- **Secure work.** Use clamps or vise to hold work when practical. It's safer than using your hand and it frees both hands to operate tool.
- **Don't overreach.** Keep proper footing and balance at all times.
- **Maintain tools with care.** Keep tools sharp and clean for best and safest performance. Follow instructions for lubricating and changing accessories.
- **Disconnect tools before servicing;** when changing accessories, such as blades, clamps, extensions, and the like.
- **Reduce the risk of unintentional starting.** Make sure the switch is in the OFF position before plugging in.
- **Use recommended accessories.** Consult the owner's manual for recommended accessories. The use of improper accessories may cause risk of injury to persons.

**WARNING!**

To reduce the risk of injury, read the instruction manual.

**WARNING!**

Read and understand all instructions. Failure to follow the warnings and instructions listed below may result in electrical shock, fire and/or serious injury.

READ ALL INSTRUCTIONS BEFORE USING THIS MITRE SAW

- **Never stand on tool.** Serious injury could occur if the tool is tipped or if something unintentionally comes into contact with the cutting tool.
- **Check damaged parts.** Before further use of the tool, a guard or other part that is damaged should be carefully checked to determine whether it will operate properly and perform its intended function - check for alignment of moving parts, binding of moving parts, breakage of parts, mounting, and any other conditions that may affect its operation. A guard or other part that is damaged should be properly repaired or replaced.
- **Direction of feed.** Feed work into a blade or cutter against the direction of rotation of the blade or cutter only.
- **Never leave tool running unattended.** Turn power off. Don't leave tool until it comes to a complete stop.

DOUBLE-INSULATED TOOLS

- **When servicing, use only identical replacement parts.**
- **Polarized Plugs:** To reduce the risk of electric shock, this equipment has a polarized plug (one blade is wider than the other). This plug will fit in a polarized outlet only one way. If the plug does not fit fully into the outlet, reverse the plug. If it still does not fit, contact a qualified electrician to install the proper outlet. Do not change the plug in any way.

ELECTRICAL SAFETY

- **To reduce the risk of electric shock, double-insulated tools are equipped with a polarized plug (one blade is wider than the other).** This plug will fit into a polarized outlet only one way. If the plug does not fit into the outlet properly, reverse the plug. If it still does not fit, contact a qualified electrician to install a polarized outlet. Do not change the plug in any way.
- **Double insulation eliminates the need for the three-wire grounded power cord and grounded power supply system.** This sliding mitre saw is a double-insulated tool.
- **Before plugging in the tool, BE SURE that the outlet voltage supplied is within the voltage marked on the tool's data plate. DO NOT use "AC only" rated tools with a DC power supply.**

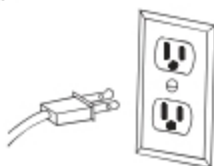

WARNING!

Do not permit fingers to touch the terminal or plug when installing or removing the plug from an outlet.



WARNING!

Double insulation DOES NOT take the place of normal safety precautions when operating this tool.

SAVE THESE INSTRUCTIONS FOR REFERENCE

- There is an increased risk of electric shock if your body is grounded.

- Water entering a power tool will increase the risk of electric shock. This tool is intended for indoor use only.

- **ALWAYS WEAR** electrician's rubber gloves and footwear in damp conditions.

- **BE SURE** to stay constantly aware of the cord location, and keep it well away from the moving blade.

- Keep cord away from heat, oil, sharp edges and moving parts. Replace damaged cords immediately. Damaged cords increase the risk of electric shock.

- Make sure your extension cord is in good condition. When using an extension cord, be sure to use one heavy enough to carry the current your product will draw. An undersized cord will cause a drop in line voltage resulting in loss of power and overheating. The following table shows the correct size to use depending on cord length and nameplate ampere rating. If in doubt, use the next heavier gauge. The smaller the gauge number, the heavier the cord.

AMPERE RATING OF TOOL (120 V CIRCUIT ONLY)		EXTENSION CORD LENGTH			
		25' / 7.6 m	50' / 15.2m	100' / 30.5	150' / 45.7m
More than	Less than	Minimum gauge for the extension cord (AWG)			
0	6	18	16	16	14
6	10	18	16	14	12
10	12	16	16	14	12
12	16	14	12	Not recommended	

**WARNING!**

For your own safety, read the Instruction Manual before operating the mitre saw.

READ ALL INSTRUCTIONS BEFORE USING THIS MITRE SAW

SAFETY RULES FOR LASER LIGHTS

THE LASER LIGHT/LASER RADIATION USED IN THE SYSTEM IS CLASS 2 WITH MAXIMUM 1MW AND 650NM WAVELENGTHS. THESE LASERS DO NOT NORMALLY PRESENT AN OPTICAL HAZARD, ALTHOUGH STARING AT THE BEAM MAY CAUSE FLASH BLINDNESS.

WARNING: Do not stare directly at the laser beam.

A hazard may exist if you deliberately stare into the beam, please observe all safety rules as follows;

- The laser shall be used and maintained in accordance with the manufacturer's instructions.
- Never aim the beam at any person or an object other than the workpiece.
- The laser beam shall not be deliberately aimed at personnel and shall be prevented from being directed towards the eye of a person for longer than ¼ second.
- Always ensure the laser beam is aimed at a sturdy workpiece without reflective surfaces ie. wood or rough coated surfaces are acceptable. Bright shiny reflective sheet steel or the like is not suitable for laser use as the reflective surface could direct the beam back at the operator.
- Do not change the laser light assembly with a different type. Repairs must be carried out by an authorised agent.



CAUTION: Use of controls or adjustments or performance of procedures other than those specified herein may result in hazardous radiation exposure.

WARNINGS.

- Do not stare directly at the laser beam. Never aim the beam at any person or an object other than the workpiece.
- Do not deliberately aim the beam at personnel and ensure that it is not directed towards the eye of a person for longer than ¼ second.
- Always ensure the laser beam is aimed at a sturdy workpiece without reflective surfaces. Wood or rough coated surfaces are acceptable. Bright shiny reflective surfaces are not suitable for laser use as the reflective surface could direct the beam back at the operator.
- Always remember to switch off the laser on/off switch (B) after finishing a job. Only turn the laser beam on when the workpiece is on the mitre saw table.
Mark the line of the cut on the workpiece.

SAVE THESE INSTRUCTIONS FOR REFERENCE

SPECIFIC SAFETY RULES FOR MITRE SAWS

- **Always wear eye protection.**
- **Do not operate the saw without guards in place.**
- **Be sure to turn the tool off and wait for the saw blade to stop** before moving the workpiece or changing settings.
- **Be sure that the power is disconnected** before changing the blade or servicing the saw.
- **Do not expose to rain or use in a damp location.**
- **When servicing, use only identical replacement parts.**
- **Never reach around the saw blade.**
- **Do not perform any operation freehand.** Always place the workpiece to be cut on the mitre saw table and position it firmly against the fence as a backstop. Always use the fence.
- **Always keep hands out of the path of the saw blade.** Do not reach under the material being cut or into the blade's cutting path with your fingers or hand for any reason.
- **To reduce the risk of injury,** return the cutting head to the full rear position after each crosscut operation.
- **Always make sure that the mitre table and head assembly (bevel function) are locked in position before operating your saw.** Lock the mitre table by securely tightening the mitre locking handle. Lock the head assembly (bevel function) by securely tightening the bevel locking knob.
- **Be sure the blade path is free of nails.** Always carefully inspect lumber and remove all nails BEFORE cutting.
- **Always be sure the blade clears the workpiece.** Never start the saw with the blade touching the workpiece. Always allow the motor to come up to full speed before starting a cut.
- **Support long workpieces when cutting to minimize the risk of blade pinching or kickback.** The saw may slip, walk or slide while cutting long or heavy boards.
- **Never use a length-stop on the free end of a clamped workpiece.** Never hold onto or bind the free end of the workpiece in any operation. If a clamp and length-stop are used together, they must both be installed on the same side of the saw table to prevent the saw from catching the loose end and kicking up.
- **Never cut more than one piece at a time.** Do not stack more than one workpiece on the worktable at a time.
- **Avoid awkward operations and hand positions where a sudden slip could cause your hand to hit the blade.** Always make sure you have good balance. Never operate your saw on the floor or in a crouched position.
- **Only use the correct blades.** Use the correct blade size, style and cutting speed for the material and the type of cut. Do not use blades with incorrect size holes. NEVER use blade washers or blade bolts that are defective or incorrect. The maximum blade capacity for this saw is 7 1/4" (18.4 cm).

READ ALL INSTRUCTIONS BEFORE USING THIS MITRE SAW

- **Always keep blades clean, sharp and properly set.** Sharp blades minimize stalling and kickback.
- **Do not use dull or damaged blades.** Bent blades can break easily or cause kickback.
- **Never hold a workpiece by hand if it is too small to be clamped.** Always keep your hands clear of the “no hands” zone.
- **Never apply lubricants to the blade when it is running.**
- **Never use solvents to clean plastic parts.** Solvents could dissolve or otherwise damage the material.
- **Do not turn the motor switch on and off rapidly.** This could cause the blade to loosen, which could create a hazard. Should this ever occur, stand clear and allow the saw blade to come to a complete stop. Disconnect the saw from the power source and tighten the blade bolt securely.
- **Never leave the saw unattended while it is connected to a power supply.**
- **Keep the motor air slots clean and free of chips or dust.** To avoid motor damage, the motor should be blown out or vacuumed frequently. This keeps sawdust from interfering with the motor ventilation.
- **Never lift this tool by gripping the switch handle or by the mitre fence.** This may cause misalignment. Always lock the head assembly in the “Down” position and carry the saw by holding the base or lift it using the carrying handle/support bracket.

ADDITIONAL RULES FOR SAFE OPERATION

- **Know your power tool.** Read the instruction manual carefully. Learn the applications and limitations, as well as the specific potential hazards related to this tool. Following these rules will reduce the risk of electric shock, fire or serious injury.
- **Always wear safety glasses or eye shields when using this saw.** Everyday eyeglasses have only impact-resistant lenses; they are NOT safety glasses. All users and bystanders MUST wear eye protection that conforms to ANSI Z87.1.
- **Protect your lungs.** Wear a face mask or a dust mask if the operation is dusty.
- **Protect your hearing.** Wear appropriate personal hearing protection during use. Under some conditions and duration of use, noise from this product may contribute to hearing loss.
- **All visitors and bystanders must wear the same safety equipment that the operator of the saw wears.**
- **Inspect the tool cords periodically and,** if damaged, have them repaired by a qualified person.
- **Always check the tool for damaged parts.** Before further use of the tool, a guard or other part that is damaged should be carefully checked to determine whether it will operate properly and perform its intended function. Check for misalignment or binding of moving parts, broken parts and any other condition that may affect the tool's operation. A guard or other part that is damaged should be properly repaired or replaced by a qualified person.

WARNING!



The use of this tool can generate and/or disperse dust, which may cause serious and permanent respiratory or other injury. Always use NIOSH/OSHA approved respiratory protection appropriate for dust exposure. Direct particles away from the face and body.

SAVE THESE INSTRUCTIONS FOR REFERENCE

- **Save these instructions. Refer to them frequently and use them to instruct others who may use this tool.** If someone borrows this tool, make sure he or she has these instructions.





GLOSSARY OF WOODWORKING TERMS

- **Spindle:** The revolving shaft on which a blade or cutting tool is mounted.
- **Spindle Lock:** Allows the user to stop the blade from rotating while tightening or loosening the blade screw during blade replacement or removal.
- **Bevel Cut:** A cutting operation made with the blade at any angle other than 90° to the mitre table.
- **Chamfer Cut:** A cut removing a wedge from a block of wood so the end (or part of the end) is angled other than at 90°.
- **Compound Mitre Cut:** A cut made using both a mitre angle and a bevel angle at the same time.
- **Crosscut:** A cutting operation made across the grain of the workpiece.
- **Freehand Cut:** Performing a cut without using a fence, mitre gauge, fixture, work clamp, or other proper device to keep the workpiece from twisting or moving during the cut. Do not perform any operation freehand. Use a clamp or vice wherever possible.
- **Kerf:** The material removed by the blade in a through cut or the slot produced by the blade in a non-through or partial cut.
- **Kickback:** A hazard that can occur when the blade binds or stalls, throwing the workpiece back toward the operator.
- **Mitre Cut:** A cutting operation made with the blade at any angle other than 90° to the fence.
- **No-Hands Zone:** The area between the marked lines on the left and right side of the mitre table base. This zone is identified by No-Hands Zone symbols inside the lines marked on the mitre table base.
- **Non-through Cut:** Any cutting operation where the blade does not extend completely through the thickness of the workpiece.
- **Revolutions Per Minute (RPM):** The number of turns completed by a spinning object in one minute.
- **Saw Blade Path:** The area over, under, behind or in front of the blade, as it applies to the workpiece; the area that will be or has been cut by the blade.
- **Set:** The distance that the saw blade tooth is bent (or set) outward from the face of the blade.
- **Throat plate:** A plate inserted in the mitre saw's table that allows for blade clearance.
- **Through Sawing:** Any cutting operation where the blade extends completely through the thickness of the workpiece.
- **Workpiece or Material:** The item on which the cutting operation is being done. The surfaces of a workpiece are commonly referred to as faces, ends and edges.

READ ALL INSTRUCTIONS BEFORE USING THIS MITRE SAW

SYMBOLS

WARNING: Some of the following symbols may appear on the sliding mitre saw. Study these symbols and learn their meaning. Proper interpretation of these symbols will allow for more efficient and safer operation of this tool.

V	Volts
A	Amperes
Hz	Hertz
W	Watts
kW	Kilowatts
μ F	Microfarads
L	Litres
kg	Kilograms
H	Hours
N/cm ²	Newtons per square centimetre
Pa	Pascals
OPM	Oscillations per minute
Min	Minutes
S	Seconds
 or a.c.	Alternating current
	Three-phase alternating current
	Three-phase alternating current with neutral
	Read all safety warnings and instructions

	Direct current
n_0	No load speed
	Alternating or direct current
	Class II construction
	Splash-proof construction
	Watertight construction
	Protective grounding at grounding terminal, Class I tools
tr/min	Revolutions or reciprocations per minute
\emptyset	Diameter
0	Off position
	Directional Arrow
	Warning symbol
	Wear your safety glasses
	Wear hearing protection



This symbol designates that this tool is listed with Canadian and U.S. requirements by ETL Testing Laboratories, Inc.

Conforms to UL Std. 62841-1:2015 and 62841-3-9:2016

Certified to CAN/CSA Std.C22.2 No. 62841-1:2015 and 62841-3-9:2016

KNOW YOUR SLIDING COMPOUND MITRE SAW

PARTS LIST

- | | |
|------------------------------|--------------------------------------|
| 1. Saw arm | 16. Table insert |
| 2. Release knob | 17. Switch trigger |
| 3. Operating handle | 18. Switch lock on |
| 4. Upper fixed blade guard | 19. Mitre lock knob |
| 5. Clamp | 20. Mitre latch |
| 6. Rotating blade guard | 21. Spindle lock |
| 7. Guard retraction arm | 22. Slide bars |
| 8. Laser light on/off switch | 23. Slide lock |
| 9. Dust bag | 24. Trenching depth adjustment screw |
| 10. Bevel lock | 25. Trenching stop |
| 11. Bevel scale | 26. Trenching depth lock nut |
| 12. Fence | 27. 45° Bevel adjustment screw |
| 13. 6mm Hex key | 28. 0° Bevel adjustment screw |
| 14. Mitre table | 29. Side supports x 2 |
| 15. Mitre scale | 30. Laser light |

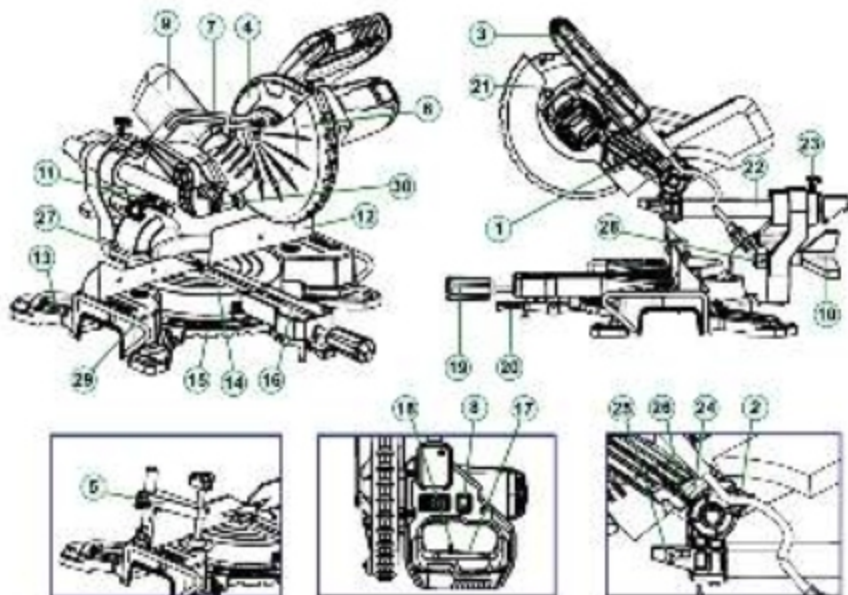

ASSEMBLY AND OPERATING

REMOVING AND INSTALLING THE BLADE

REMOVING BLADE (FIG. 1 TO 4)

- Unplug the tool from the power source.
- Adjust the lock-down pin to raise the cutting head.
- Loosen the cover plate screw (1) about 4 turns with a star-head screwdriver. Do not remove this screw from the tool.
- Lift and hold up the lower blade guard (2) to expose the threaded blade bolt (3).
- Press and hold the spindle-lock button (4) and rotate the blade at the same time, until it is locked in position.
- Continue to hold the spindle lock button to keep it engaged, while using the wrench to turn the threaded blade bolt clockwise and remove the threaded blade bolt.
- Remove the outer flange (5) and the blade (6). Wipe the flanges and spindle to remove any dust and debris.

INSTALLING BLADE (FIG. 1 TO 4)

Unplug the mitre saw before changing/installing the blade.

- Install a 7 1/4" (18.4 cm) blade with 5/8" (15.9 mm) arbor onto the arbor shaft (7). Match the arrow on the blade with the arrow on the upper blade guard. Make sure that the blade teeth are pointing downward.

NOTE:

Pay attention to the pieces being removed, noting their position and the direction they face. Wipe the blade collar clean of any sawdust before installing a new blade.



WARNING!

Always be sure that the tool is switched off and unplugged before adjusting or checking function on the tool. Failure to switch off and unplug the tool may result in serious personal injury from accidental start-up.



WARNING!

Only use a 7 1/4" (18.4 cm) diameter blade. To avoid injury from an accidental start, make sure the switch is in the OFF position and the plug is not connected to the power source outlet.

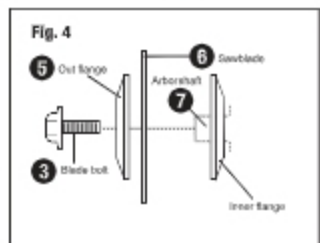
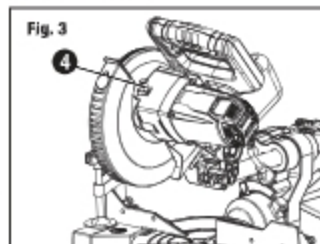
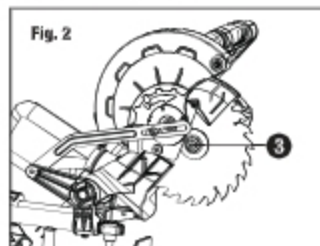
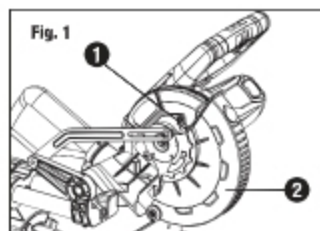

- Place the out flange against the blade and on the arbor. Thread the blade bolt onto the arbor in a counterclockwise direction.
- Place the blade hex wrench into the blade bolt.
- Press the spindle lock button, holding it in firmly while turning the blade counterclockwise. When spindle lock engages, continue to press it in while tightening the blade bolt securely.
- Rotate the lower blade guard back to its original position until the slot in the cover plate engages with the cover plate screw. While holding the lower blade guard, tighten the screw with a Phillips screwdriver.
- Verify that the operation of the guard does not bind or stick.
- Be sure the spindle lock is released so the blade turns freely before operating the saw.

IMPORTANT:

Make sure the flats of the out flange are engaged with the flats on the arbor shaft. Also, the flat side of the out flange collar must be placed against the blade.

NOTE:

The lower blade guard must be in the right position to access the cover plate screw.



WARNING!

- To avoid injury, never use the saw without the cover plate securely in place. It keeps the blade bolt from falling out if it accidentally loosens and helps prevent the spinning blade from coming off the saw.
- Make sure the flanges are clean and properly arranged. Lower the blade into the lower table and check for any contact with the metal base or the mitre table.
- To avoid injury from an accidental start, make sure the switch is in the OFF position and the plug is not connected to the power source outlet.
- Never cut metals or masonry products with this tool. This mitre saw is designed for use on wood and wood-like products only.

INSTALLING THE DUST BAG (Fig. 5)

- Squeeze the metal collar wings on the dust bag.
- Place the dust bag neck opening around the exhaust port on the mitre saw and release the metal collar wings.

MITRE SCALE (Fig. 6)

The sliding compound mitre saw scale can be easily read, showing mitre angles from 0° to 45° to the left, and 0° to 45° to the right. The mitre saw table has nine of the most common angle settings with positive stops at 0°, 15°, 22.5°, 31.6° and 45°. These positive stops position the blade at the desired angle quickly and accurately. Follow the process below for quickest and most accurate adjustments.

This tool is carefully adjusted and aligned at the factory, but rough handling may have affected the alignment. If your tool is not aligned properly, perform the following as needed.

TO ADJUST MITRE ANGLES:

- Unlock the table by turning the mitre handle (1) counterclockwise.
- Move the table while lifting up on the positive stop locking lever (2) to align the indicator (3) to the desired degree measurement.
- If the desired angle is one of the nine positive stops, release the positive stop locking lever, making sure the lever snaps into position, and then secure by tightening the mitre handle.
- If the mitre angle desired is not one of the nine positive stops, simply lock the table into desired angle position by turning the mitre handle in the clockwise direction.

IMPORTANT:

Check bag frequently and empty it before it gets full.

NOTE:

To empty the dust bag, remove it from exhaust port. Open zipper on underside of bag and empty into waste container.

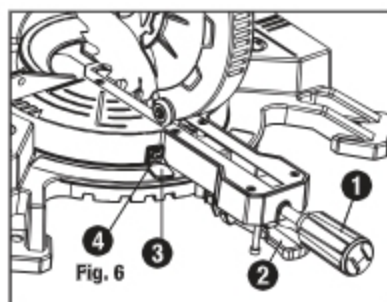
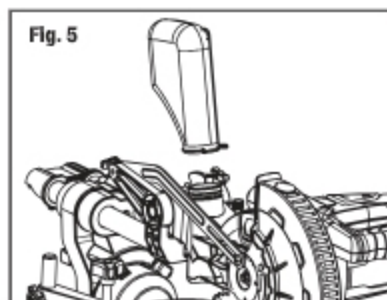
**WARNING!**

Do not use this saw to cut and/or sand metals. The hot chips or sparks may ignite sawdust from the bag material.

MITRE ANGLE POINTER ADJUSTMENT (FIG. 6)

- Move the table to the 0° positive stop.
- Loosen the screw (4) that holds the indicator with a Phillips screwdriver.
- Adjust the indicator (3) to the 0° mark and retighten the screw.

ADJUSTING FENCE SQUARENESS (Fig. 7)

- Lower the cutting head and lock in position.
- Using a square (1), lay the heel of the square against the blade and the ruler against the fence (2) as shown.
- Loosen the two fence locking bolts (3) with a 6 mm hex wrench.
- Adjust the fence 90° to the blade and tighten the two fence locking bolts.
- After fence has been aligned, make a cut at 90° using a scrap piece of wood and check squareness on the piece. Readjust if necessary.

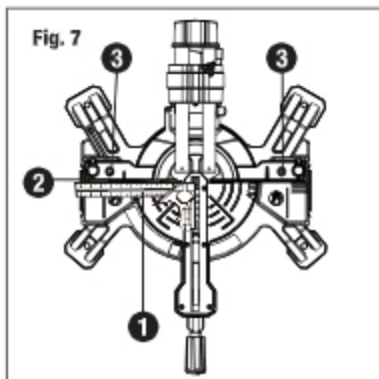
**BEVEL STOP ADJUSTMENT**

This tool is carefully adjusted and aligned at the factory, but rough handling may have affected the alignment. If your tool is not aligned properly, perform the following as needed.

90° (0°) BEVEL ADJUSTMENT (FIG. 8)

- Loosen bevel lock knob (1) and tilt the pivot arm completely to the right. Tighten the bevel lock knob.
- Place a combination square (2) on the mitre table with the ruler against the table and the heel of the square against the saw blade.

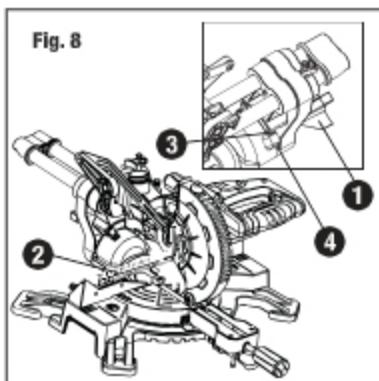
**WARNING!**

To avoid injury from an accidental start, make sure the switch is in the OFF position and the plug is not connected to the power source outlet.

**WARNING!**

To reduce the risk of injury, wear safety goggles or glasses with side shields.

- If the blade is not 90° square with the table, loosen the bevel lock knob, tilt the cutting head to the left, loosen the locknut (3) and turn the bevel angle adjustment bolt (4) in or out with a 3 mm hex wrench until the blade is square with the table.
- Tilt the pivot arm back to the right at 90° (0°) bevel and recheck for alignment.
- Repeat steps if further adjustment is needed.
- Tighten bevel lock knob and locknut (3) when alignment is achieved.

90° Bevel Pointer Adjustment (FIG. 9)

When the blade is exactly 90° to the table, loosen the bevel indicator screw (1) using a star-head screwdriver.

- Adjust bevel indicator (2) to the "0" mark on the bevel scale and retighten the screw.



45° Bevel Adjustment (FIG. 10)

- Loosen the bevel lock knob (1) and tilt the cutting head completely to the left.
- Using a combination square, check to see if the blade is at a 45° angle to the table.
- If the blade is not at 45° to the mitre table, tilt the pivot arm to the right, loosen the locknut (2) on the bevel angle adjustment bolt (3) wrench to the adjust bolt depth in or out to increase or decrease the bevel angle.
- Tilt the cutting arm to the left to 45° bevel and recheck for alignment.
- Repeat steps until the blade is at 45° to the mitre table.
- Tighten bevel lock knob and locknut when alignment is achieved.

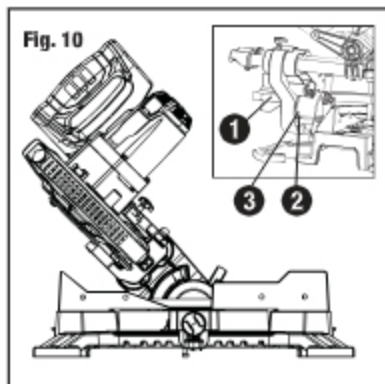

MAXIMUM CUTTING DEPTH (FIG. 11)

The maximum depth travel of the cutting head was set at the factory. Check to see that the blade does not extend more than 5/16" / 0.8 cm below the table insert, and does not touch the control arm throat or any part of the base or table. If the maximum depth needs readjusting:

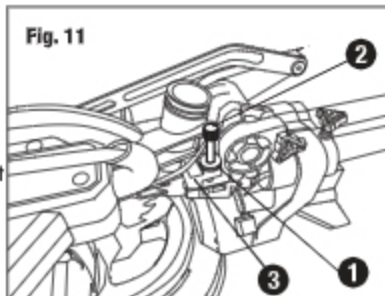

- Loosen the locknut (1) to free the depth screw (2).
- Move the cutting head down until the blade extends just $\frac{5}{16}$ " / 0.8 cm below the table insert.
- Adjust the depth screw to touch the stop plate (3), then tighten the locknut to secured the depth screw.
- Recheck the blade depth by moving the cutting head front to back through the full motion of a cut along the control arm. If the blade touches the inside of the control arm, readjust the setting.
- When it is properly set, tighten the locknut to lock the depth screw.

UNLOCKING AND LOCKING THE CUTTING HEAD (Fig. 12)

To unlock: Press and lightly hold down the cutting head. Pull out the lock-down pin (1) to release the cutting head. The cutting head should freely move up.

To lock: Place the cutting head at the lowest position. Secure the position and push the stop lock pin into the locking position. Please note, if there is any cutting depth setting, the lock in may not work. Release the cutting depth limitation, and then lock the cutting head in.

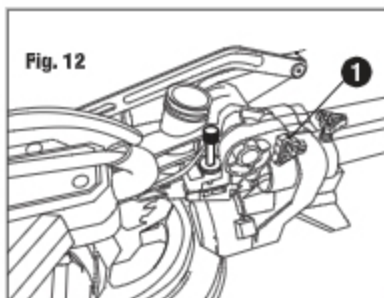

Fig. 12

UNLOCKING THE SLIDE CARRIAGE (Fig. 13)

After removing the saw from the carton, loosen the slide carriage lock knob (1). When transporting or storing the mitre saw, the slide carriage should always be locked in position. The slide carriage lock knob is located on the upper side of the slide carriage.

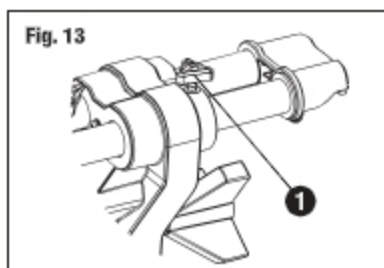

Fig. 13

IMPORTANT:

To avoid damage, never carry the mitre saw by the switch handle, the cutting arm or the mitre table handle. ALWAYS use the handholds for transportation.



CAUTION!

To avoid injury and damage to the saw, transport and store the mitre saw with the cutting head locked in the down position. Never use the stop pin to hold the cutting head in a down position for cutting operations.



CAUTION!

Always make sure that the spindle lock button is released so the blade can rotate freely. MAKE SURE that the locking pin is loose and the cutting head moves freely up and down. ENSURE that all clamps and locks are tightly in place, and that there is no excessive play in any parts.



WARNING!

Before each use, verify that the blade is free of cracks, loose teeth, missing teeth, or any other damage. Do not use if damage is observed or suspected.

Always wait for the blade to stop completely, and unplug the tool before changing accessories or making adjustments.

BENCH MOUNTING (Fig. 14)

This tool should be bolted with four bolts to a level and stable surface using the bolt holes (1) provided in the tool's base. This will help prevent tipping and possible injury.

INSTALLING THE WORK CLAMP (Fig. 15)

There are two mounting holes for the work clamp. These are located just behind the fence on the left and right side of the base.

- Loosen the locking screw with a Phillips screwdriver.
- Place the work clamp in the desired mounting hole.
- Tighten the screw to hold the work clamp.

ON/OFF TRIGGER SWITCH (Fig. 16)

This tool is equipped with lock-off switches (1) to prevent unintentional starting. To turn the saw on, push the lock-off switch (1), then depress the switch trigger (2). To turn the tool off, release the switch trigger.

When the trigger switch is released, the blade will be stopped within 10 seconds.

ON/OFF laser (Fig.17)

The laser is turned ON and OFF with the same switch (1). To turn the switch ON, press the front edge of the switch. To turn the switch OFF, press the rear edge of the switch.

DRY RUN

For safe operation, it's necessary to know where the blade will contact the workpiece during the cutting process. Always perform the simulated cutting process with the switch off to check and understand the projected path of the saw blade. Adjust the work clamps and fences to avoid any contact with the lower guard and cutting action.

Fig. 14

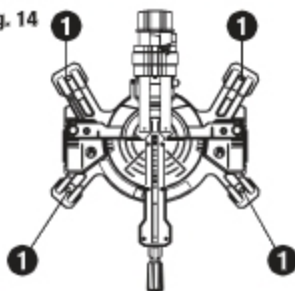

Fig. 15

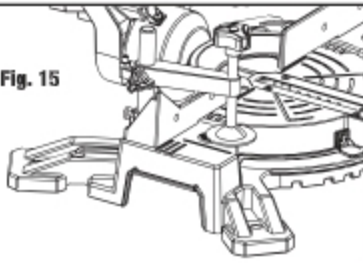

Fig. 16

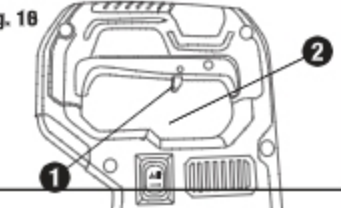

Fig. 17

**WARNING!**

Ensure that the tool will not move on the supporting surface. Movement of the mitre saw on the supporting surface while cutting may result in loss of control and serious personal injury.

**WARNING!**

- To avoid injury, after completing a cut and releasing the trigger switch, wait and confirm that the blade has stopped before raising the cutting head.
- To avoid injury, check and tighten the blade bolt periodically.

MITRE CUT (Fig. 18)

- When a mitre cut is required, unlock the table by turning the mitre handle (1) counterclockwise.
- While holding the mitre handle, lift up on the positive stop locking lever (2).
- Rotate the table to the right or left with the mitre handle.
- When the table is in the desired position, as shown on the mitre scale (3), release the positive stop locking lever and tighten the mitre handle. The table is now locked at the desired angle. Positive stops are provided at 0°, 15°, 22.5°, 31.6° and 45°.

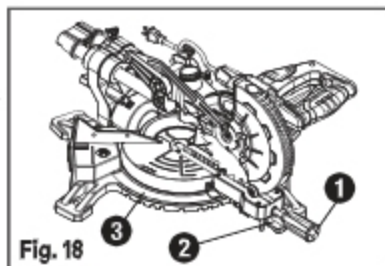
**Fig. 18****BEVEL CUT (Fig. 19)**

- When a bevel cut is required, loosen the bevel lock knob (1) by turning it clockwise.
- Tilt the cutting head to the desired angle, as shown on the bevel scale (2).
- The blade can be positioned at any angle, from a 90° straight cut (0° on the scale) to a 45° left bevel. Tighten the bevel lock knob to lock the cutting head in position. Positive stops are provided at 0° and 45°.

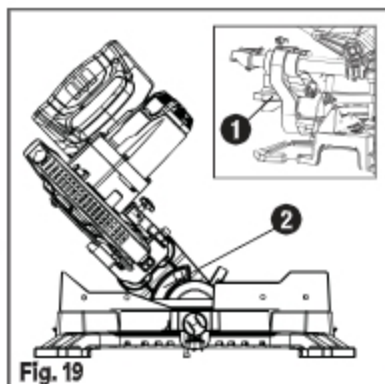
**Fig. 19****COMPOUND CUT (Fig. 20)**

A compound cut is the combination of a mitre and a bevel cut simultaneously.

- Loosen the bevel lock knob (1) and position the cutting head at the desired bevel position. Lock the bevel lock knob.
- Loosen the mitre handle (2). Lift up the positive stop locking lever (3) and position the table at the desired angle. Release the positive stop locking lever and lock the mitre handle.

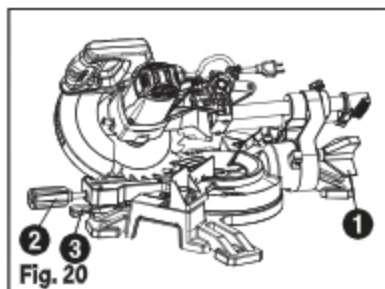
**Fig. 20****IMPORTANT:**

Always tighten the mitre table lock handle before performing every cutting operation.

SLIDING CARRIAGE SYSTEM (Fig. 21)

- For chop cutting operations on small workpieces, slide the cutting head completely toward the rear of the unit and tighten the carriage lock knob (1).
- To cut wide boards up to 8" (20.3 cm), the carriage lock knob must be loosened to allow the cutting head to slide freely.

SLIDE CUTTING WIDE BOARDS UP TO 8"/20.3 CM WIDE**TO AVOID INJURY:**

- Let the blade reach full speed before cutting. This will help reduce the risk of a thrown workpiece.
- Do not make crosscuts by lowering the blade and pulling the cutting head through the wood toward you.

TO SLIDE CUT WIDE BOARDS (FIG. 22)

- Unlock the carriage lock knob (1) and allow the cutting head assembly to move freely.
- Set both the desired bevel angle and/or the mitre angle and lock into position.
- Use a work clamp (2) to secure the workpiece (3).
- Grasp and pull the switch handle (4) forward until the centre of the saw blade is over the front of the workpiece.
- Engage the trigger to turn the saw on.
- When the saw reaches full speed, slowly push the switch handle down, cutting through the leading edge of the workpiece.
- Slowly move the switch handle toward the fence, completing the cut.
- Release the trigger and allow the blade to stop spinning before raising the cutting head and removing the workpiece.

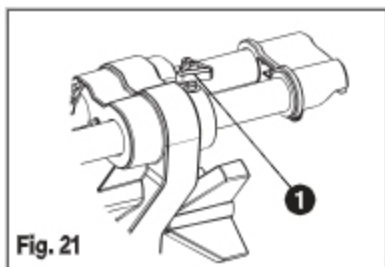

Fig. 21

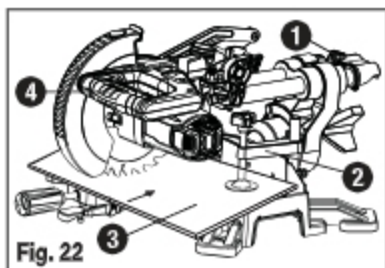

Fig. 22

**CAUTION!**

To reduce the risk of injury, return carriage to the full rear position after each crosscut operation.

CAUTION!

Always use a work clamp to maintain control and reduce the risk of workpiece damage and personal injury.

SETTING CUTTING DEPTH (Fig. 23)

The depth of cut can be preset for even and repetitive shallow cuts.

- Loosen the locknut (1) to free the lock knob (2), turn the lock knob. Using the handle, lower the cutting head down until the teeth of the blade are at the desired depth.
- While holding the upper arm in that position, tighten the locknut to secured the stop knob.
- Recheck the blade depth by moving the cutting head front to back through the full motion of typical cut along the control arm.

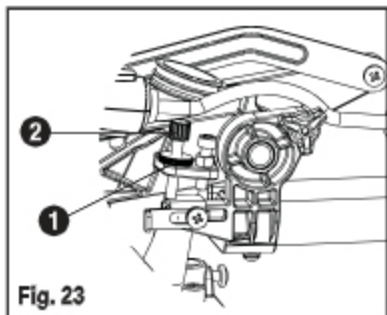
**Fig. 23****CUTTING GROOVES (Fig. 24)**

- Mark lines to identify the width and depth of the desired cut on the workpiece and put the workpiece on the table and aim the inside tip of the blade at the line. Use a work clamp to secure the workpiece on the table.
- Lower the cutting head so the tip of the blade touches the top surface of the workpiece at the marked line.
- While holding the upper arm in position, loosen the locknut and turn the stop knob until it touches the stop plate, then retighten the lock nut. (SEE "SETTING CUTTING DEPTH")
- Cut two parallel grooves as shown.
- Use a wood chisel or make multiple passes with a router to remove the material between the two outside grooves to create the groove.

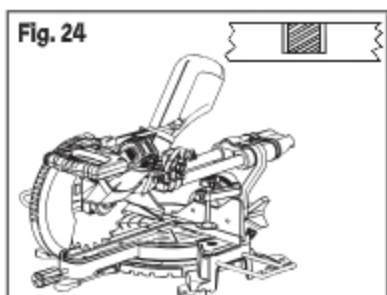
**Fig. 24****NOTE:**

Always perform a dry run cut so you can determine if the operation being attempted is possible before power is applied to the saw.

**WARNING!**

DO NOT USE A DADO BLADE, use only the standard saw blade for this operation.

CUTTING WARPED MATERIAL (Fig. 25)

When cutting warped material, be sure that the convex side is against the fence. If the workpiece is placed with the concave side facing the fence, it will pinch the blade near the completion of the cutting.

AUXILIARY WOOD FENCE (Fig. 26)

When making multiple or repetitive cuts that result in cut-off pieces of 1" / 2.5 cm or less, it is possible for the saw blade to catch the cut-off piece and throw it out of the saw or into the blade guard and housing, possibly causing damage or injury. To minimize this, an auxiliary wood fence can be mounted to your saw. Holes are provided in the saw fence to attach an auxiliary wood fence (this provides additional depth of cut). This fence should be constructed of straight auxiliary wood approximately 3/4" / 1.9 cm thick by 1 1/2" / 3.8 cm high by 16" / 40.6 cm long. Attach the wood fence securely and make a full depth cut to make a blade slot. Check for interference between the wood fence and the lower blade guard. Adjust if necessary.

CUTTING BASE MOULDING (Fig. 27)

Base mouldings and many other mouldings can be cut on a sliding compound mitre saw. The setup of the saw depends on moulding characteristics and applications, as shown. Perform practice cuts on scrap material to achieve best results:

- Always make sure mouldings rest firmly against the fence and table. Use hold-down or C-clamps, whenever possible, and place tape on the area being clamped to avoid marks.
- Reduce splintering by taping the cut area prior to making cut. Mark cut line directly on the tape.
- Splintering typically happens due to wrong blade application and thinness of the material.

NOTE:

Always perform a dry run cut so you can determine if the operation being attempted is possible before power is applied to the saw.

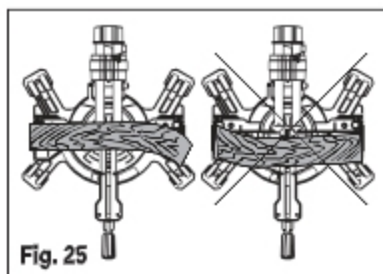
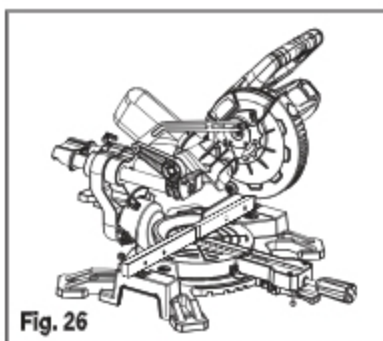
**Fig. 25****Fig. 26****Fig. 27**

CUTTING CROWN MOULDING (Fig. 28, 29)

Your sliding compound mitre saw is suited for the difficult task of cutting crown moulding. To fit properly, crown moulding must be compound mitre cut with extreme accuracy. The two surfaces on a piece of crown moulding that fit flat against the ceiling and wall are at angles that, when added together, equal exactly 90°.

Most crown moulding has a top rear angle (the section that fits flat against the ceiling) of 52° and a bottom rear angle (the section that fits flat against the wall) of 38°.

In order to accurately cut crown moulding for a 90° inside or outside corner, lay the moulding with its broad back surface flat on the saw table. When setting the bevel and mitre angles for compound mitres, remember the settings are interdependent; changing one changes the other, as well.

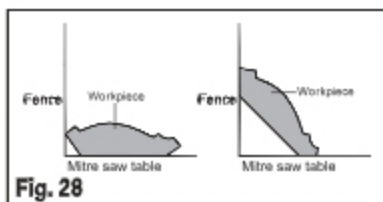

Fig. 28

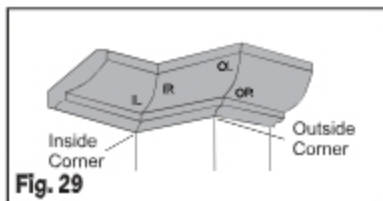

Fig. 29

BEVEL/MITRE SETTINGS (WHEN THE ANGLE BETWEEN THE WALLS EQUALS 90°)

KEY	BEVEL SETTING	MITRE SETTING	TYPE OF CUT
INSIDE CORNER - LEFT SIDE			
IL	33.9°	31.6° Right	1. Position top of moulding against fence. 2. Mitre table set at right 31.6°. 3. Left side is finished piece.
INSIDE CORNER - RIGHT SIDE			
IR	33.9°	31.6° Left	1. Position bottom of moulding against fence. 2. Mitre table set at left 31.6°. 3. Left side is finished piece.
OUTSIDE CORNER - LEFT SIDE			
OL	33.9°	31.6° Left	1. Position bottom of moulding against fence. 2. Mitre table set at left 31.6°. 3. Right side is finished piece.
OUTSIDE CORNER - RIGHT SIDE			
OR	33.9°	31.6° Right	1. Position top of moulding against fence. 2. Mitre table set at right 31.6°. 3. Right side is finished piece.

SAWDUST

Periodically, sawdust will accumulate under the table and base. This could cause difficulty in the movement of the table when setting up a mitre cut. Frequently blow out or vacuum up the sawdust.

LOWER BLADE GUARD

Do not use the saw without the lower blade guard.

The lower blade guard is attached to the saw for your protection. Should the lower guard become damaged, do not use the saw until the damaged guard has been replaced. Check regularly to make sure the lower guard is working properly. Clean the lower guard of any dust or buildup with a damp cloth.

REPLACING CARBON BRUSHES (Fig. 30)

Replace both carbon brushes when either has less than 1/4" / 0.6 cm length of carbon remaining, or if the spring or wire is damaged or burned. To inspect or replace brushes, first unplug the saw. Remove the two screws on the back cover of the motor and take the cover off. Move the coil spring which press on the carbon brush to other side to free the carbon brush. Pull out the brush and the wire which connect to the holder. Replace it for a new carbon brush. When replace for the other side. To reassemble, reverse the procedure. Tighten two screws on the back cover.

Fig. 30

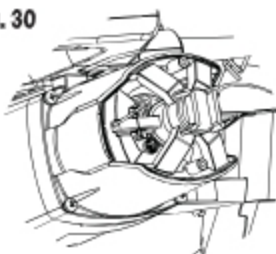

NOTE:

To reinstall the same brushes, first make sure the brushes go back in the way they came out.



CAUTION!

If blowing sawdust, wear proper eye protection to keep debris from blowing into eyes.



CAUTION!

- Do not use solvents on the guard. They could make the plastic cloudy and brittle.
- When cleaning the lower guard, unplug the saw to avoid unexpected start-up.



WARNING!

- To avoid fire or toxic reaction, never use gasoline, naphtha acetone, lacquer thinner or similar highly volatile solvents to clean the mitre saw.
- To avoid injury from unexpected starting or electrical shock, unplug the power cord before working on the saw.
- For your safety, this saw is double-insulated. To avoid electrical shock, fire or injury, use only parts identical to those identified in the parts list. Reassemble exactly to avoid electrical shock.

LUBRICATION (Fig. 31)

All the motor bearings in this tool are lubricated with a sufficient amount of high-grade lubricant for the life of the unit under normal operating conditions; therefore, no further lubrication is required.

LUBRICATE THE FOLLOWING AS NECESSARY:

Chop pivot: Apply light machine oil to points indicated in illustration.

Central pivot of plastic guard: Use light household oil (sewing machine oil) on metal-to-metal or metal-to-plastic guard contact areas as required for smooth, quiet operation.

Avoid excessive oil as sawdust will cling to it.

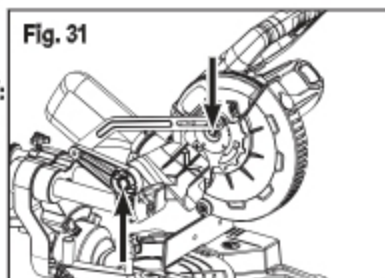

TROUBLESHOOTING

PROBLEM	POSSIBLE CAUSE	SOLUTION
Brake does not stop blade within 10 seconds.	Motor brushes not sealed or lightly sticking.	Inspect/clean/replace brushes.
	Motor brake overheated from use of defective or wrong size blade or rapid On/Off cycling.	Use a recommended blade.
	Arbor bolt is loose.	Retighten.
Motor does not start.	Brush worn.	Replace brushes.
	Power source fuse or time delay fuse.	Check time delay fuse or circuit breaker.
Angle of cut inaccurate.	Mitre table unlocked.	Rotate the mitre locking handle all the way to the right.
	Too much sawdust under table.	Vacuum or blow out dust while wearing eye protection.
Head assembly cannot fully raise or blade guard cannot fully close.	Parts failure.	Contact service centre.
	Pivot spring not replaced properly after service.	Contact service centre.
	Sawdust build-up.	Clean and lubricate moving parts.
	Lock-down pin not set properly.	Check, adjust and properly set sawhead locking pin.
Blade binds, jams or burns wood.	Improper operation.	See Operating Instructions section.
	Dull blade.	Replace or sharpen blade.
	Improper blade.	Replace blade.
	Warped blade.	Replace blade.
Blade hits table.	Misalignment.	See Assembly and Adjustments section.
Brush sparks excessively when switch is released.	Brush worn/damaged.	Replace brushes.
Saw vibrates or shakes.	Saw blade damaged.	Replace blade.
	Saw blade loose.	Tighten bolt.
	Saw not properly fastened down.	Fasten saw to stand, bench or table.
	Workpiece not properly supported.	Properly support or clamp workpiece.

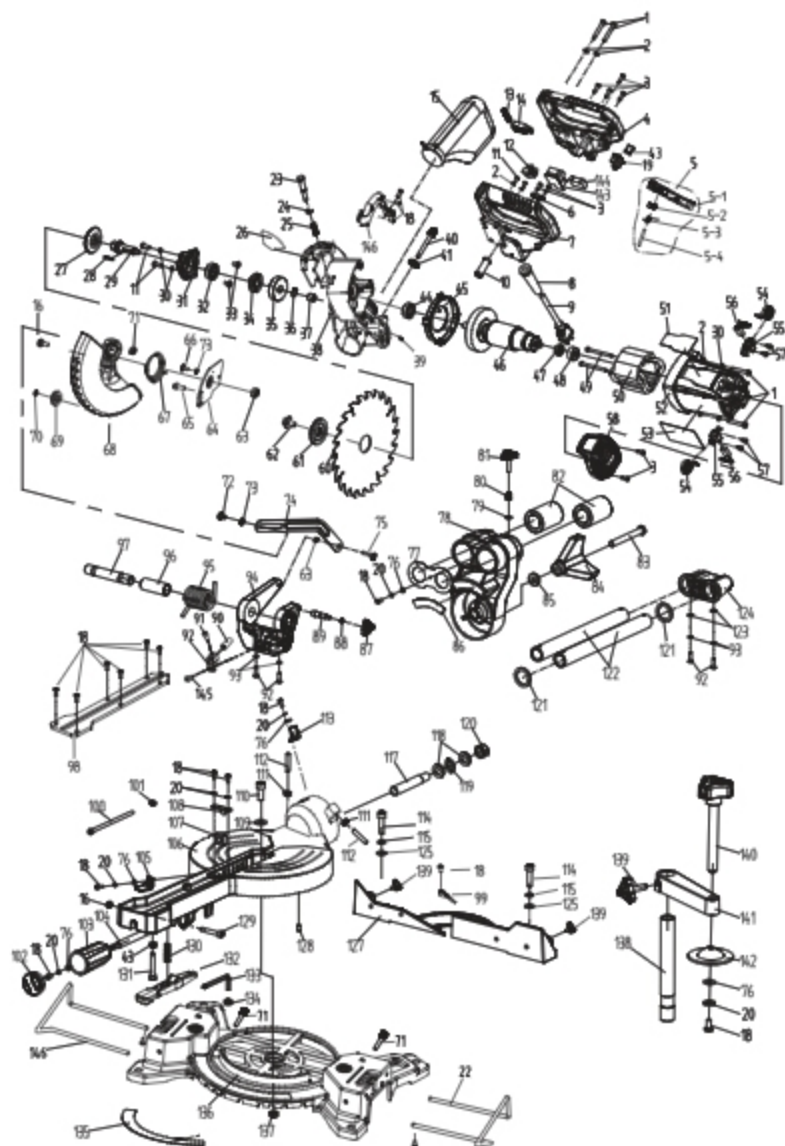

PARTS LIST

⚠ WARNING: When servicing, use only original equipment replacement parts. The use of any other parts may create a safety hazard or cause damage to the mitre saw.

Any attempt to repair or replace electrical parts on this grass trimmer may create a safety hazard unless repairs are performed by a qualified technician. For more information, call the Toll-free Helpline, at 1-866-349-8665 – Friday from 9am to 5pm Eastern Standard Time

Always order by PART NUMBER, not by key number.

Key #	Part #	Part Name	Quantity
1	1347-000-1	Cross head screws	6
2	1347-000-2	Washer	13
3	1347-000-3	Self -tapping screws	10
4	1347-000-4	Upper handle	1
5	1347-000-5	Switch trigger assembly	1
5-1	1347-000-5-1	Switch trigger	1
5-2	1347-000-5-2	Switch trigger key	1
5-3	1347-000-5-3	Spring	1
5-4	1347-000-5-4	Pin	1
6	1347-000-6	Cord press plate	1
7	1347-000-7	Lower handle	1
8	1347-000-8	Cable sheath	1
9	1347-000-9	Power cord	1
10	1347-000-10	Inner wire sleeve	1
11	1347-000-11	Screw	5
12	1347-000-12	Terminal	1
13	1347-000-13	Trigger spring	1
14	1347-000-14	Micro-switch	1
15	1347-000-15	Dust bag	1
16	1347-000-16	Shoulder screws	1
18	1347-000-18	Screws	18
19	1347-000-19	Laser Switch	1
20	1347-000-20	Spring washer	10
22	1347-000-22	Right extension bar	1
23	1347-000-23	Spindle lock pin	1
24	1347-000-24	C ring	1
25	1347-000-25	Spindle lock pin spring	1
26	1347-000-26	Brand label	1
27	1347-000-27	Inner flange	1
28	1347-000-28	Flat key	1
29	1347-000-29	Spindle	1
30	1347-000-30	Spring washer	8

PARTS

Key #	Part #	Part Name	Quantity
31	1347-000-31	Gear box cover	1
32	1347-000-32	Bearing	1
33	1347-000-33	Screw	2
34	1347-000-34	Spindle lock stop plate	1
35	1347-000-35	Gear	1
36	1347-000-36	Check ring	1
37	1347-000-37	Copper sleeve	1
38	1347-000-38	Fix guard	1
39	1347-000-39	Set screws	1
40	1347-000-40	Depth adjuster	1
41	1347-000-41	Knurled nut	1
43	1347-000-43	Laser switch cover	1
44	1347-000-44	Bearing	1
45	1347-000-45	Fan baffle	1
46	1347-000-46	Armature	1
47	1347-000-47	Bearing	1
48	1347-000-48	Bearing sleeve	1
49	1347-000-49	Tapping screw	2
50	1347-000-50	Stator	1
51	1347-000-51	Rating label	1
52	1347-000-52	Motor housing	1
53	1347-000-53	Warning label	1
54	1347-000-54	Brush spring	2
55	1347-000-55	Brush holder	2
56	1347-000-56	Carbon Brush	2
57	1347-000-57	Tapping screw	4
58	1347-000-58	End cap	1
60	1347-000-60	Blade	1
61	1347-000-61	Outer flange	1
62	1347-000-62	Socket screws	1
63	1347-000-63	Lock nut	2
64	1347-000-64	Move guard support	1
65	1347-000-65	Screws	1
66	1347-000-66	Shoulder screws	1
67	1347-000-67	Spring	1
68	1347-000-68	Move guard	1
69	1347-000-69	Move guard wheel	1
70	1347-000-70	Inner tooth washer	1
71	1347-000-71	Knob	4
72	1347-000-72	Shoulder screws	1
73	1347-000-73	Wave washer	1
74	1347-000-74	Linkage	1
75	1347-000-75	Screws	1

PARTS

Key #	Part #	Part Name	Quantity
76	1347-000-76	Washer	1
77	1347-000-77	Bearing cover	1
78	1347-000-78	Bevel Arm	1
79	1347-000-79	Washer	1
80	1347-000-80	Spring	1
81	1347-000-81	Knob	1
82	1347-000-82	Linear bearing	2
83	1347-000-83	Hex bolt	1
84	1347-000-84	Bevel locker	1
85	1347-000-85	Washer	1
86	1347-000-86	Bevel scale	1
87	1347-000-87	Lock pin knob	1
88	1347-000-88	O-ring	1
89	1347-000-89	Lock pin	1
90	1347-000-90	Laser	1
91	1347-000-91	Socket screws	1
92	1347-000-92	Laser holder	1
93	1347-000-93	Spring washer	4
94	1347-000-94	Bracket	1
95	1347-000-95	Big torsion spring	1
96	1347-000-96	Spring sleeve	1
97	1347-000-97	Pivot shaft	1
98	1347-000-98	Table insert	1
99	1347-000-99	"Rip fence extension block"	1
100	1347-000-100	Socket screws	1
101	1347-000-101	Hex nut	1
102	1347-000-102	Handle cap	1
103	1347-000-103	Mitre handle	1
104	1347-000-104	Mitre angle lock rod	1
105	1347-000-105	Mitre indicator	1
106	1347-000-106	Turn table	1
107	1347-000-107	Square nut	1
108	1347-000-108	Lock plate	1
109	1347-000-109	Washer	1
110	1347-000-110	Hex screw	1
111	1347-000-111	Hex nut	2
112	1347-000-112	Set screws	2
113	1347-000-113	Bevel indicator	1
114	1347-000-114	Hex screw	4
115	1347-000-115	Spring washer	6
117	1347-000-117	Rotary shaft	1
118	1347-000-118	Washer	2
119	1347-000-119	Wave washer	1
120	1347-000-120	Locknut	1

PARTS

Key #	Part #	Part Name	Quantity
121	1347-000-121	Rubber ring	2
122	1347-000-122	Guide bar	2
123	1347-000-123	Washer	2
124	1347-000-124	Slide end cap	1
125	1347-000-125	Washer	2
127	1347-000-127	Fence	1
128	1347-000-128	Set screws	1
129	1347-000-129	Screws	1
130	1347-000-130	Spring	1
131	1347-000-131	Hex screw	1
132	1347-000-132	Location push button	1
133	1347-000-133	Hex key	1
134	1347-000-134	Hex key store	1
135	1347-000-135	Miter scale	1
136	1347-000-136	Base	1
137	1347-000-137	Lock nut	1
138	1347-000-138	Support pole	1
139	1347-000-139	Knob	3
140	1347-000-140	Clamp screw knob	1
141	1347-000-141	Clamp arm	1
142	1347-000-142	Clamp	1
143	1347-000-143	Transformer	1
144	1347-000-144	Capacitor	1
145	1347-000-145	Screws	1
146	1347-000-146	Extension bar	1

WARRANTY

RADLEY 7 1/4" SLIDING COMPOUND MITRE SAW

If this Radley Tool fails due to a defect in material or workmanship within three years from the date of purchase, return it to any Home Hardware store with the original bill of sale for exchange. Two years for battery and charger. This warranty does not include expendable parts including but not limited to blades, brushes, belts and light bulbs. This warranty covers defects in material or workmanship only. It does not cover normal wear and tear, failure due to abuse/misuse, or defects caused by careless or accidental mishandling. If this Radley product is used for commercial or rental purposes, this warranty does not apply. For use at the consumer level. The warranty is not for industrial or commercial applications.

9.5A, 7 1/4"
Sliding Compound

Miter Saw



Owner's
Manual



3 Year
limited
warranty

Radley

EXCLUSIVE TO HOME HARDWARE

For information on the entire line-up of Radley power tools visit homehardware.ca or your local Home Hardware retail store.

MADE IN CHINA • FABRICATED IN THE
HOME HARDWARE STORES LIMITED
21 JARDIN ST. WILLOW PARK ONT
ORDER ONLINE: [HOMEHARDWARE.CA](http://homehardware.ca)

©2012 Home Hardware Stores Ltd. All Rights Reserved



1347-000