

BENCHMARKTM_{MC}

10" COMPACT TABLE SAW



Item # 1346-631

LIMITED
5 YEAR*
WARRANTY

5 Year Limited Warranty on tool

C US
JF72558

**READ ALL INSTRUCTIONS BEFORE FIRST USE.
KEEP THIS MANUAL FOR FUTURE REFERENCE.
KEEP AWAY FROM CHILDREN.
SEE NEXT PAGE FOR CRITICAL TOOL RELATED
PRECAUTIONS.**



**WEAR CSA APPROVED
EYE PROTECTION**



**WEAR EAR
PROTECTION**



**WEAR A
FACE MASK**

PRODUCT SPECIFICATIONS

10" COMPACT TABLE SAW

Motor	120V~60 Hz, 15 A
Blade diameter	10" (254 mm) 40T carbide tipped
No load speed	4800 RPM
Arbor size	5/8" (16 mm)
Rip capacity	25" (64cm)
Bevel range	0-45° (Right side)
Mitre range	0-60° (Left/Right side)
Maximum cutting angle	45°
Max cutting depth	Cross cut @ 90° -3-1/8" (8 cm) Bevel cut @ 45°-2.3" (5.8 cm)
Table height	35" (89.2 cm)
Main table size	22" (56 cm) x 22.25" (56.5 cm)
Maximum extension	25.6" (65 cm) x 40.5" (103 cm)
Right extension size	4.3"(11 cm) x 22" (56 cm)
Weight	67.2 LBS (30.5 KG)

REPLACEMENT PARTS AVAILABLE AT HOME HARDWARE

Replacement blade	1221-026
-------------------	----------

CRITICAL TOOL RELATED PRECAUTIONS

1. Ensure the saw is plugged into a 120V, 15A grounded outlet to avoid electrical damage.
2. Secure blades and components, always check the blade and safety guards are properly installed and secure before use.
3. Avoid overloading the tool; don't cut materials beyond the saw's capacity and feed material at a steady pace.
4. Follow safety procedures and always wear safety gear and keep hands clear of the blade; unplug the saw when adjusting or changing blades.

READ ALL SAFETY, WARNING, PRECAUTIONS AND MAINTENANCE INFORMATION PROVIDED IN THIS MANUAL.

EXTENSION CORD SAFETY

STOP! When using an extension cord (**NOT INCLUDED**) with your electric tool refer to the following table to determine the required AWG wire size. Before using your tool make sure the power cord and extension cord are in good working conditions. Make repairs or replacements before using the tool. Only use extension cords that are rated for outdoor use.

⚠ WARNING: Consult the extension cord guide table to ensure the correct extension cord is used with the tool. Use of an extension cord that is insufficiently rated for the tool may result in tool under-performance, overheating, fire, and tool failure.

⚠ WARNING: Keep the extension cord clear of the working area. Position the cord so that it will not get caught on the workpiece, tools or any other obstructions while you are working with the power tool.

Make sure any extension cord used with this tool is in good condition. When using an extension cord, be sure to use one of heavy enough gauge to carry the current the tool will draw. An undersized cord will cause a drop in voltage resulting in loss of power and overheating.

The table below shows the correct size to use according to cord length and name plate ampere rating. If in doubt, use the next heavier gauge. The smaller the gauge number, the heavier the cord.

Be sure your extension cord is properly wired and in good condition. Always replace a damaged extension cord or have it repaired by a qualified electrician before using it. Protect your extension cord from sharp objects, excessive heat and damp or wet areas.

Use a separate electrical circuit for your power tools. This circuit must not be less than 14 gauge wire and should be protected with either a 15AMP time delayed fuse or circuit breaker. Before connecting the power tool to the power source, make sure the switch is in the OFF position and the power source is the same as indicated on the nameplate. Running at lower voltage will damage the motor.

120V OUTDOOR GRADE EXTENSION CORD LENGTH & GAUGE GUIDE

Outdoor Rated		Total length			
More than	Not more than	25' /7.5 m	50' /15 m	100' /30 m	150' /45 m
0	6A	18	16	16	14
6A	10A	18	16	14	12
10A	12A	16	16	14	12
13A	16A	14	12	Not Applicable	

NOTE: Bolded values are recommendations for this tool.

To reduce the risk of disconnect of tool from the extension cord during operation, make a knot as shown in Fig. 1A

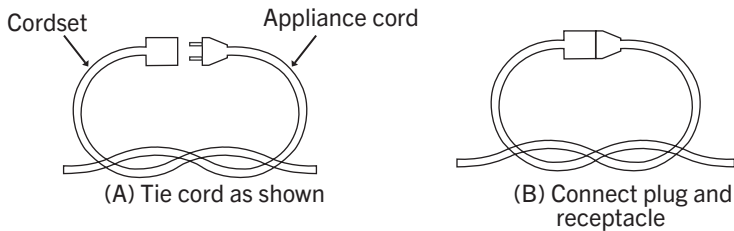

FIG. 1A

⚠ WARNING: Use a plug receptacle retaining strap to ensure a proper connection and to ensure there is no strain on the connection. A poor or strained connection can lead to sparking, voltage drop and damage to the tool, overheating, intermittent tool operation, and fire.

Avoid unintentional starting - Turn off the power switch and disconnect the power cord before making any adjustments to the unit and before inspecting, servicing, changing accessories or cleaning.

Handle cord carefully- Never pull electric tool by cord or yank it to disconnect from the power source. Keep cord away from heat, oil, and sharp edges.

Don't force electric tool- it will do the job better and with less likelihood of a risk of injury at the rate for which it was designed.

Don't overreach- Keep proper footing and balance at all times.

Stay Alert- Watch what you are doing. Use common sense. Do not operate tool when you are tired or under the influence of alcohol, drugs, or medications that cause drowsiness.

Disconnect electric tool - Disconnect the electric tool from the power supply when not in use, before servicing, when changing accessories.

Keep guards in place.

Keep hands and feet away from moving parts.

NEED ASSISTANCE?

Call us on our toll-free customer support line:
1-866-349-8665 (Monday through Friday 9am – 5pm Eastern Standard Time)

- Technical questions
- Replacement parts
- Parts missing from package

TABLE OF CONTENTS

Product specifications	1-3
Table of contents	4
General safety warnings	5-9
Specific safety warnings	9-17
Symbols	18
Know your compact table saw	19
Assembly and operating	20-31
Maintenance	32
Troubleshooting	33
Exploded view	34
Parts list	35-39
Warranty	40

GENERAL SAFETY WARNINGS

IMPORTANT SAFETY INSTRUCTIONS









Read and understand all safety and operational instructions. Failure to follow the safety rules listed below and other basic safety precautions may result in serious personal injury. Keep this manual, sales receipts and applicable warranty forms for future reference.

⚠ WARNING: To avoid serious personal injury, do not attempt to use this product until you have read this instruction manual thoroughly and understand it completely. If you do not understand the warnings and instructions in this manual, do not use this product. Call 1-866-349-8665 for assistance. The operation of any power tool can result in foreign objects being thrown into your eyes, which can result in severe eye damage. Before beginning power tool operation, always wear safety goggles or safety glasses with side shields and when needed, a full-face shield. We recommend a wide vision safety mask for use over eyeglasses or standard safety glasses with eye shields. Always use eye protection which is marked to comply with ANSI Z87.1 or CSA requirements. Prescription glasses ARE NOT a replacement for proper eye protection.

Safety Symbols

The purpose of safety symbols is to alert you of the potential safety RISKS. Recognize and understand them. Follow the instructions provided.

 SYMBOL	MEANING
 DANGER	Failure to obey a DANGER safety alert WILL result in serious personal injury or death to you or to others. Always obey all messages following this symbol to reduce the risk of serious personal injury or death.
 WARNING	Failure to obey a WARNING safety alert MAY result in serious personal injury or death to you or to others. Always obey all messages following this symbol to reduce the risk of potential serious personal injury or death.
 CAUTION	Failure to obey a CAUTION safety alert MAY result in personal injury or property damage to you or to others. Always obey all messages following this symbol to reduce the risk of personal injury or property damage.
NOTICE CAUTION	Failure to obey a NOTICE or a CAUTION (without a safety alert) MAY result in property damage to you or to others. Always obey all messages following this symbol to reduce the risk of property damage.

SYMBOL	MEANING
<p>⚠ DANGER</p>  	<p>ALWAYS WEAR EYE PROTECTION THAT CONFORMS WITH CSA Z94.3 or ANSI SAFETY STANDARD Z87.1</p> <p>FLYING DEBRIS can cause permanent eye damage. Prescription eyeglasses ARE NOT a replacement for proper eye protection. The usage of a safety standard compliant face shield placed over proper safety glasses or goggles can reduce the risk of facial injury.</p> <p>Non-compliant eyewear can cause serious injury if broken during the operation of a power tool.</p>
<p>⚠ WARNING</p> 	<p>Use hearing protection, particularly during extended periods of operation of the tool, or if the operation is noisy.</p>
<p>⚠ WARNING</p> 	<p>WEAR A DUST MASK THAT IS DESIGNED TO BE USED WHEN OPERATING A POWER TOOL IN A DUSTY ENVIRONMENT.</p>
<p>⚠ WARNING</p>   	<p>Always wear non-slip gloves that fit properly to protect your hands and to help you grip the tool.</p> <p>Always wear sturdy clothing with long sleeves and long pants. Never operate the tool while wearing shorts, short sleeve shirts or shirtless.</p> <p>Always wear non-slip safety boots to prevent foot injuries and slipping that could cause loss of control of the tool.</p>
<p>⚠ WARNING</p> 	<p>To avoid electrical hazards, fire hazards or damage to the tool, use proper circuit protection.</p> <p>This tool is wired at the factory for 120 V AC operations. It must be connected to a 120 V AC, 15 A circuit that is protected by a time-delayed fuse or circuit breaker. To avoid shock or fire, replace power cord immediately if it is worn, cut or damaged in any way.</p>

GENERAL SAFETY WARNINGS

⚠ WARNING: Read all safety warnings and all instructions. Failure to follow the warnings and instructions may result in electric shock, fire and/or serious injury.

Save all warnings and instructions for future reference.

The term "power tool" in the warnings refers to your mains-operated (corded) power tool or battery-operated (cordless) power tool.

1) Work area safety

- a) **Keep the work area clean and well lit.** Cluttered and dark areas invite accidents.
- b) **Do not operate electric tools in explosive atmospheres, for example in the presence of flammable liquids, gases or dust.** Electric tools create sparks that can ignite the dust or fumes.
- c) **Keep children and bystanders away while operating the tool.** Distractions can cause you to lose control of the tool.

2) Electrical safety

- a) **Power tool plugs must match the outlet. Never modify the plug in any way.** Do not use any adapter plugs with earthed (grounded) power tools. Unmodified plugs and matching outlets will reduce risk of electric shock.
- b) **Avoid body contact with earthed or grounded surfaces, such as pipes, radiators, ranges and refrigerators.** There is an increased risk of electric shock if your body is earthed or grounded.
- c) **Do not expose power tools to rain or wet conditions.** Water entering a power tool will increase the risk of electric shock.
- d) **Do not abuse the cord. Never use the cord for carrying, pulling or unplugging the power tool.** Keep cord away from heat, oil, sharp edges or moving parts. Damaged or entangled cords increase the risk of electric shock.
- e) **When operating a power tool outdoors, use an extension cord suitable for outdoor use.** Use of a cord suitable for outdoor use reduces the risk of electric shock.
- f) **If operating a power tool in a damp location is unavoidable, use a ground fault circuit interrupter (GFCI) protected supply.** Use of a GFCI reduces the risk of electric shock.

3) Personal safety

- a) **Stay alert, watch what you are doing and use common sense when operating a power tool.** Do not use a power tool while you are tired or under the influence of drugs, alcohol or medication. A moment of inattention while operating power tools may result in serious personal injury.
- b) **Use personal protective equipment. Always wear eye protection.** Protective equipment such as a dust mask, non-skid safety shoes, hard hat or hearing protection used for appropriate conditions will reduce personal injuries.

- c) **Prevent unintentional starting. Ensure the switch is in the off-position before connecting to power source and/or battery pack, picking up or carrying the tool.** Carrying power tools with your finger on the switch or energising power tools that have the switch on invites accidents.
- d) **Remove any adjusting key or wrench before turning the power tool on.** A wrench or a key left attached to a rotating part of the power tool may result in personal injury.
- e) **Do not overreach. Keep proper footing and balance at all times.** This enables better control of the power tool in unexpected situations.
- f) **Dress properly. Do not wear loose clothing or jewellery.** Keep your hair, clothing and gloves away from moving parts. Loose clothes, jewellery or long hair can be caught in moving parts.
- g) **If devices are provided for the connection of dust extraction and collection facilities, ensure these are connected and properly used.** Use of dust collection can reduce dust-related hazards.
- h) **Do not let familiarity gained from frequent use of tools allow you to become complacent and ignore tool safety principles.** A careless action can cause severe injury within a fraction of a second.
- i) **Only use safety equipment that has been approved by an appropriate standards agency.** Unapproved safety equipment may not provide adequate protection. Eye protection must be ANSI-approved and breathing protection must be NIOSH-approved for the specific hazards in the work area.
- j) **Avoid unintentional starting.** Prepare to begin work before turning on the tool.
- k) **Do not leave the tool unattended when it is plugged into an electrical outlet.** Turn off the tool, and unplug it from its electrical outlet before leaving.
- l) **This product is not a toy.** Keep it out of reach of children.
- m) **People with pacemakers should consult their physician(s) before use.** Electromagnetic fields in close proximity to heart pacemaker could cause pacemaker interference or pacemaker failure. In addition, people with pacemakers should:
- Avoid operating alone.
 - Do not use with trigger locked on.
 - Properly maintain and inspect to avoid electrical shock.
 - Properly ground power cord. Ground Fault Circuit Interrupter (GFCI) should also be implemented – it prevents sustained electrical shock.
- n) **The warnings, precautions, and instructions discussed in this instruction manual cannot cover all possible conditions and situations that may occur.** It must be understood by the operator that common sense and caution are factors which cannot be built into this product, but must be supplied by the operator.
- 4) Power tool use and care**
- a) **Do not force the power tool. Use the correct power tool for your application.** The correct power tool will do the job better and safer at the rate for which it was designed.
- b) **Do not use the power tool if the switch does not turn it on and off.** Any power tool that cannot be controlled with the switch is dangerous and must be repaired.

- c) **Disconnect the plug from the power source and/or remove the battery pack, if detachable, from the power tool before making any adjustments, changing accessories, or storing power tools.** Such preventive safety measures reduce the risk of starting the power tool accidentally.
- d) **Store idle power tools out of the reach of children and do not allow persons unfamiliar with the power tool or these instructions to operate the power tool.** Power tools are dangerous in the hands of untrained users.
- e) **Maintain power tools and accessories. Check for misalignment or binding of moving parts, breakage of parts and any other condition that may affect the power tool's operation. If damaged, have the power tool repaired before use.** Many accidents are caused by poorly maintained power tools.
- f) **Keep cutting tools sharp and clean.** Properly maintained cutting tools with sharp cutting edges are less likely to bind and are easier to control.
- g) **Use the power tool, accessories and tool bits etc. in accordance with these instructions, taking into account the working conditions and the work to be performed.** Use of the power tool for operations different from those intended could result in a hazardous situation.
- h) **Keep handles and grasping surfaces dry, clean and free from oil and grease.** Slippery handles and grasping surfaces do not allow for safe handling and control of the tool in unexpected situations.
- i) **Hold power tools by the insulated gripping surfaces when performing an operation where the cutting tool may contact hidden wiring or its own cord.** Contact with a "live" wire will make exposed metal parts of the tool "live" and shock the operator.

Service

Have your power tool or charger serviced by a qualified repair person using only identical replacement parts. This will ensure that the safety of the power tool or charger is maintained.

SPECIFIC SAFETY RULES

 **WARNING:** Know your tool. Do not plug in the tool or insert battery(s) until you have read and understand this Instruction Manual. Learn the tool's limitations, as well as the general and specific potential hazards related to this tool's applications and following these instructions will reduce the risk of electric shock, fire or serious injury.



Always wear appropriate eye protection. Any power tool can throw foreign objects into your eyes and cause permanent eye damage. Always wear appropriate safety goggles or properly fitted safety glasses that comply with the most recent version of ANSI Z87.1 safety standard. Ordinary vision or sunglasses generally do not provide adequate impact or side shield / wrap around penetration protection. Ordinary glasses ARE NOT safety glasses. To reduce the risk of injury to your face you should also wear a face shield over your safety goggles or safety glasses.

⚠ WARNING: DO NOT let comfort or familiarity with product (gained from repeated use) replace strict adherence to the tool safety rules. If you use this tool unsafely or incorrectly, you can suffer serious personal injury.

⚠ DANGER: When the tool is in operation, keep hands away from the saw blade and the area it is being applied to. Failure to follow this warning will result in amputation, serious personal injury or death.

⚠ DANGER: Some surfaces contain materials which can be toxic. When working on materials that may contain lead, asbestos, copper chromium arsenate or other toxic materials, extra care should be taken to avoid inhalation and minimize skin contact.

- **TO REDUCE THE RISK OF KICKBACK AND OTHER INJURIES**, use all components of the guarding system (blade guard assembly) for every operation for which they can be used including all through cutting.
- **REMOVE ADJUSTING KEYS AND WRENCHES.** Form habit of checking to see that keys and adjusting wrenches are removed from spindle before turning tool on. Tools, scrap pieces, and other debris can be thrown at high speed, causing injury.
- **DO NOT USE THE MACHINE IN A DANGEROUS ENVIRONMENT.** The use of power tools in damp or wet locations or in rain can cause shock or electrocution. Keep your work area well-lit to avoid tripping or placing arms, hands, and fingers in danger.
- **MAKE WORKSHOP CHILDPROOF** with padlocks, master switches, or by removing starter keys. The unauthorized start-up of a machine by a child or visitor may result in injury.
- **DO NOT FORCE TOOL.** It will do the job better and be safer at the rate for which it was designed.
- **USE THE RIGHT TOOL.** Don't force tool or attachment to do a job for which it was not designed. Using the incorrect tool or attachment may result in personal injury.
- **USE PROPER EXTENSION CORD.** Make sure your extension cord is in good condition. When using an extension cord, be sure to use one heavy enough to carry the current your product will draw. An undersized cord will cause a drop in line voltage resulting in loss of power and overheating. Refer to the chart in this manual.
- **WEAR PROPER APPAREL.** No loose clothing, gloves, neckties, rings, bracelets, or other jewellery to get caught in moving parts. Non-slip footwear is recommended. Wear protective hair covering to contain long hair. Air vents may cover moving parts and should also be avoided.
- **SECURE WORK.** Use clamps to hold work when practical (such as when cutting a zero clearance insert/throat plate). It's safer than using your hand and it frees both hands to operate tool.

- **ALWAYS USE SAFETY GLASSES.** Everyday eyeglasses are NOT safety glasses. Also use face or dust mask if cutting operation is dusty. All users and bystanders MUST ALWAYS wear certified safety equipment:
 - ANSI Z87.1 eye protection (CAN/CSA Z94.3),
 - ANSI S12.6 (S3.19) hearing protection,
 - NIOSH/OSHA/MSHA respiratory protection.
- **DO NOT OVERREACH.** Keep proper footing and balance at all times. Loss of balance may cause personal injury. Do not attempt to retrieve materials near the blade on the saw table while the blade is spinning.
- **MAINTAIN TOOLS WITH CARE.** Keep blades sharp and clean for best and safest performance. Follow instructions for lubricating and changing accessories. Poorly maintained blades and machines can further damage the blade or machine and/or cause injury.
- **TURN THE MACHINE “OFF” AND DISCONNECT THE MACHINE FROM THE POWER SOURCE** before installing or removing accessories, before adjusting or changing set-ups, when making repairs or changing locations. Do not touch the plug’s metal prongs when unplugging or plugging in the cord. An accidental start-up can cause injury.
- **KEEP ARMS, HANDS AND FINGERS AWAY** from the blade to prevent serious injury.
- **REDUCE THE RISK OF UNINTENTIONAL STARTING.** Make sure that the switch is in the “OFF” position before plugging in the power cord. In the event of a power failure, move the switch to the “OFF” position. An accidental start-up can cause injury.
- **DO NOT** plug into or unplug from power source with wet hands.
- **USE RECOMMENDED ACCESSORIES.** Use only accessories that are recommended by the manufacturer for your model. Accessories that may be suitable for one tool may be hazardous when used on another tool. Consult the instruction manual for recommended accessories. The use of improper accessories may cause risk of injury to persons. Magnetic accessories will not work on this saw.
- **NEVER STAND OR SIT ON TOOL.** Serious injury could occur if the tool is tipped or if the cutting tool is unintentionally contacted.
- **CHECK FOR DAMAGED PARTS.** Before further use of the tool, a guard or other part that is damaged should be carefully checked to determine that it will operate properly and perform its intended function—check for alignment of moving parts, binding of moving parts, breakage of parts, mounting and any other conditions that may affect its operation. A guard or other part that is damaged should be properly repaired or replaced. Do not use tool if switch does not turn it on and off. Damaged parts can cause further damage to the machine and/or personal injury.
- **DIRECTION OF FEED.** Feed work into a blade or cutter against the direction of rotation of the blade or cutter only. No cove cutting or freehand cuts. Check for adequate out-feed distance behind the saw to be sure materials can pass unobstructed through the cut. Work support tables should be placed in proper locations to fully support the material.
- **NEVER LEAVE TOOL RUNNING UNATTENDED.** TURN POWER OFF. Don’t leave tool until it comes to a complete stop. Serious injury can result.

- **DO NOT OPERATE ELECTRIC TOOLS NEAR FLAMMABLE LIQUIDS OR IN GASEOUS OR EXPLOSIVE ATMOSPHERES.** Motors and switches in these tools may spark and ignite fumes.
- **STAY ALERT, WATCH WHAT YOU ARE DOING, AND USE COMMON SENSE. DO NOT USE THE MACHINE WHEN YOU ARE TIRED OR UNDER THE INFLUENCE OF DRUGS, ALCOHOL, OR MEDICATION.** A moment of inattention while operating power tools may result in serious injury.
- **DO NOT ALLOW FAMILIARITY (gained from frequent use of this saw) TO REPLACE SAFETY RULES.** Always remember that a careless fraction of a second is sufficient to inflict severe injury. Use extra caution and stay alert when making repetitive cuts. Turn off saw frequently to clean up saw dust and check adjustments to reduce monotony.
- **AVOID AWKWARD POSITIONS,** where a sudden slip could cause a hand to move into a saw blade.
- **NEVER REACH IN BACK OF, OR AROUND, THE CUTTING TOOL** with either hand to hold down the workpiece.
- **DO NOT PERFORM RIPPING, CROSSCUTTING OR ANY OTHER OPERATION FREEHAND.**
- **NEVER** reach around or over saw blade.
- **STABILITY.** Make sure the table saw is firmly mounted to a secure surface before use and does not move.
- **NEVER CUT METALS, CEMENT BOARD OR MASONRY.** Certain man-made materials have special instructions for cutting on table saws. Follow the manufacturer's recommendations at all times. Damage to the saw and personal injury may result.
- **THE PROPER THROAT PLATE MUST BE LOCKED IN PLACE AT ALL TIMES.** To reduce the risk of a thrown workpiece and possible injury.
- **USE THE CORRECT SAW BLADE FOR THE INTENDED OPERATION.** The blade must rotate toward the front of the saw. Always tighten the blade arbor nut securely. Before use, inspect the blade for cracks or missing teeth. Do not use a damaged or dull blade.
- **NEVER ATTEMPT TO FREE A STALLED SAW BLADE WITHOUT FIRST TURNING THE MACHINE OFF AND DISCONNECTING THE SAW FROM THE POWER SOURCE.** If a workpiece or cut-off piece becomes trapped inside the blade guard assembly, turn saw off and wait for blade to stop before lifting the blade guard assembly and removing the piece.
- **NEVER START THE MACHINE** with the workpiece against the blade to reduce the risk of a thrown workpiece and personal injury.
- **DO NOT HAVE ANY PART OF YOUR BODY IN LINE WITH THE BLADE.** Personal injury may occur. Stand to either side of the blade.
- **NEVER PERFORM LAYOUT, ASSEMBLY OR SET-UP WORK** on the table/work area when the machine is running. A sudden slip could cause a hand to move into the blade. Severe injury can result.
- **CLEAN THE TABLE/WORK AREA BEFORE LEAVING THE MACHINE.** Lock the switch in the "OFF" position and disconnect from the power source to prevent unauthorized use.
- **ALWAYS** lock the fence and bevel adjustment before cutting.

- **DO NOT** leave a long board (or other workpiece) unsupported so the spring of the board causes it to shift on the table resulting in loss of control and possible injury. Provide proper support for the workpiece, based on its size and the type of operation to be performed. Hold the work firmly against the fence and down against the table surface.
- **USE RECOMMENDED ACCESSORIES.** The use of improper accessories may cause risk of personal injury.
- **DO NOT OPERATE THIS MACHINE** until it is completely assembled and installed according to the instructions. A machine incorrectly assembled can cause serious injury.

⚠ WARNING: All electrical connections must be done by a qualified electrician. Failure to comply may result in serious injury!
All adjustments or repairs must be done with the machine disconnected from the power source. Failure to comply may result in serious injury!

1) Guarding related warnings

- a) Keep guards in place. Guards must be in working order and be properly mounted.** A guard that is loose, damaged, or is not functioning correctly must be repaired or replaced.
- b) Always use saw blade guard, riving knife and anti-kickback pawls for every through-cutting operation.** For through-cutting operations where the saw blade cuts completely through the thickness of the workpiece, the guard and other safety devices help reduce the risk of injury.
- c) After completing a non-through cut such as rabbeting, resawing, or dadoing, restore the riving Knife to the extended-up position, With the riving knife in the extended-up position, reattach the blade guard and the anti-kickback pawls.** The guard, riving knife, and anti-kickback pawls help to reduce the risk of injury
- d) Make sure the saw blade is not contacting the guard, riving knife or the workpiece before the switch is turned on.** Inadvertent contact of these items with the saw blade could cause a hazardous condition.
- e) Adjust the riving knife as described in this instruction manual.** Incorrect spacing, positioning and alignment can make the riving knife ineffective in reducing the likelihood of kickback.
- f) For the riving knife and anti-kickback pawls to work, they must be engaged in the workpiece.** The riving knife and anti-kickback pawls are ineffective when cutting workpieces that are too short to be engaged with the riving knife and anti-kickback pawls. Under these conditions a kickback cannot be prevented by the riving knife and antikickback pawls.
- g) Use the appropriate saw blade for the riving knife.** For the riving knife to function properly, the saw blade diameter must match the appropriate flying knife, and the body of the saw blade must be thinner than the thickness of the riving knife and the cutting width of the saw blade must be wider than the Thickness of the riving knife.

2) Cutting procedures warnings

⚠ DANGER: Never place your fingers or hands in the vicinity or in line with the saw blade. A moment of inattention or a slip could direct your hand towards the saw blade and result in serious personal injury.

- b) Feed the workpiece into the saw blade or cutter only against the direction of rotation.** Feeding the workpiece in the same direction that the saw blade is rotating above the table may result in the workpiece, and your hand being pulled into the saw blade.
- c) Never use the miter gauge to feed the workpiece when ripping and do not use the rip fence as a length stop when cross cutting with the miter gauge.** Guiding the workpiece with the rip fence and the miter gauge at the same time increases the likelihood of saw blade binding and kickback.
- d) When ripping, always keep the workpiece in full contact with the fence and always apply the workpiece feeding force between the fence and the saw blade.** Use a push stick when the distance between the fence and the saw blade is less than 150 mm; and use a push block (not supplied) when this distance is less than 50 mm. "Work helping" devices will keep your hand at a safe distance from the saw blade.
- e) Use only the push stick provided by the manufacturer or constructed in accordance with the instructions.** This push stick provides sufficient distance of the hand from the saw blade.
- f) Never use a damaged or cut push stick.** A damaged or cut push stick may break causing your hand to slip into the saw blade.
- g) Do not perform any operation "freehand". Always use either the rip fence or the mitre gauge to position and guide the workpiece.** "Freehand" means using your hands to support or guide the workpiece, in lieu of a no fence or miter gauge. Freehand sawing leads to misalignment, binding and kickback.
- h) Never reach around or over a rotating saw blade.** Reaching for a workpiece may lead to accidental contact with the moving saw blade.
- i) Provide auxiliary workpiece support to the rear and/or sides of the saw table for long and/or wide workpieces to keep them level.** A long and/or wide workpiece has a tendency to pivot on the table's edge, causing loss of control, saw blade binding and kickback.
- j) Feed the workpiece at an even pace. Do not bend, twist or shift the workpiece from side to side.** If jamming occurs, turn the tool off immediately, unplug the tool then clear the jam. Jamming the saw blade by the workpiece can cause kickback or stall the motor.
- k) Do not remove pieces of cut-off material while the saw is running.** The material may become trapped between the fence or inside the saw blade guard and the saw blade pulling your fingers into the saw blade. Turn the saw off and wait until the saw blade stops before removing material.
- l) Use an auxiliary fence in contact with the tabletop when ripping workpieces less than 2 mm thick.** A thin workpiece may wedge under the rip fence and create a kickback.

3) Kickback causes and related warnings

Kickback is a sudden reaction of the workpiece due to a pinched, jammed saw blade or misaligned line of cut in the workpiece with respect to the saw blade or when a part of the workpiece binds between the saw blade and the rip fence or other fixed object.

Most frequently during kickback, the workpiece is lifted from the table by the rear portion of the saw blade and is propelled towards the operator.

Kickback is the result of saw misuse and/or incorrect operating procedures or conditions and can be avoided by taking proper precautions as given below.

- a) **Never stand directly in line with the saw blade. Always position your body on the same side of the saw blade as the fence.** Kickback may propel the workpiece at high velocity towards anyone standing in front and in line with the saw blade.
- b) **Never reach over or in back of the saw blade to pull or to support the workpiece.** Accidental contact with the saw blade may occur or kickback may drag your fingers into the saw blade.
- c) **Never hold and press the workpiece that is being cut off against the rotating saw blade.** Pressing the workpiece being cut off against the saw blade will create a binding condition and kickback.
- d) **Align the fence to be parallel with the saw blade.** A misaligned fence will pinch the workpiece against the saw blade and create kickback.
- e) **Use a feather-board to guide the workpiece against the table and fence when making non-through cuts such as rabbeting, dadoing or re-sawing cuts.** A feather-board helps to control the workpiece in the event of a kickback.
- f) **Use extra caution when making a cut into blind areas of assembled workpieces.** The protruding saw blade may cut objects that can cause kickback.
- g) **Support large panels to minimize the risk of saw blade pinching and kickback.** Large panels tend to sag under their own weight. Support (s) must be placed under all portions of the panel overhanging the tabletop.
- h) **Use extra caution when cutting a workpiece that is twisted, knotted, warped or does not have a straight edge to guide it with a miter gauge or along the fence.** A warped, knotted, or twisted workpiece is unstable and causes misalignment of the kerf with the saw blade, binding and kickback.
- i) **Never cut more than one workpiece, stacked vertically or horizontally.** The saw blade could pick up one or more pieces and cause kickback.
- j) **When restarting the saw with the saw blade in the workpiece, center the saw blade in the kerf so that the saw teeth are not engaged in the material.** If the saw blade binds, it may lift up the workpiece and cause kickback when the saw is restarted.
- k) **Keep saw blades clean, sharp, and with sufficient set.** Never use warped saw blades or saw blades with cracked or broken teeth. Sharp and properly set saw blades minimize binding, staffing and kickback.

- l) Be certain that the rip fence is parallel to the saw blade.
- m) Do not rip by applying the feed force to the section of the workpiece that will become the cut-off (free) piece. Feed force when ripping should always be applied between the saw blade and the fence; use a push stick for narrow work.
- n) Keep saw blade guard assembly and riving knife in place and operating properly. The riving knife must be in alignment with the saw blade and must stop a kickback once it has started. Check their action before ripping by pushing the wood under the guard. The teeth must prevent the wood from being pulled toward the front of the saw.
- o) Use saw blade guard assembly, and riving knife for every operation for which it can be used, including all thru sawing.
- p) Push the workpiece past the saw blade prior to release.
- q) NEVER rip a workpiece that is twisted or warped, or does not have a straight edge to guide along the fence.
- r) NEVER saw a large workpiece that cannot be controlled.
- s) NEVER use the fence as a guide or length stop when crosscutting.
- t) NEVER rip a workpiece shorter than 10" (254 mm).
- u) NEVER use a dull blade – replace or have resharpened.
- v) NEVER saw a workpiece with loose knots, flaws, nails or other foreign objects.

















4) Table saw operating procedure warnings

- a) **Turn off the table saw and disconnect the power cord when removing the table insert, changing the saw blade or making adjustments to the riving knife, antikickback pawls or saw blade guard, and when the machine is left unattended.** Precautionary measures will avoid accidents.
- b) **Never leave the table saw running unattended. Turn it off and don't leave the tool until it comes to a complete stop.** An unattended running saw is an uncontrolled hazard.
- c) **Locate the table saw in a well-lit and level area where you can maintain good footing and balance.** It should be installed in an area that provides enough room to easily handle the size of your workpiece. Cramped, dark areas, and uneven slippery floors invite accidents.
- d) **Frequently clean and remove sawdust from under the saw table and/or the dust collection device.** Accumulated sawdust is combustible and may self-ignite.
- e) **The table saw must be secured.** A table saw that is not properly secured may move or tip over.
- f) **Remove tools, wood scraps, etc. from the table before the table saw is turned on.** Distraction or a potential jam can be dangerous.
- g) **Always use saw blades with correct size and shape (diamond versus round) of arbour holes.** Saw blades that do not match the mounting hardware of the saw will run off-centre, causing loss of control.

- h) Never use damaged or incorrect saw blade mounting means such as flanges, saw blade washers, bolts or nuts.** These mounting means were specially designed for your saw, for safe operation and optimum performance.
- i) Never stand on the table saw, do not use it as a stepping stool.** Serious injury could occur if the tool is tipped or if the cutting tool is accidentally contacted.
- j) Make sure that the saw blade is installed to rotate in the proper direction.** Do not use grinding wheels, wire brushes or abrasive wheels on a table saw. Improper saw blade installation or use of accessories not recommended may cause serious injury.

SYMBOLS

⚠ WARNING: Some of the following symbols may appear on the tool. Study these symbols and learn their meaning. Proper interpretation of these symbols will allow for more efficient and safer operation of this tool.

Symbols	Descriptions	Symbols	Descriptions
	READ THE OPERATOR'S MANUAL(S) – Read, understand and follow all instructions in the user manual(s) before attempting to assemble and operate.		Keep bystanders and children a safe distance away.
	SAFETY ALERT – Indicates a precaution, a warning or a danger.		WARNING! Do not expose the unit to rain or wet conditions.
	Beware of flying objects and debris.		Wear hearing protection. Wear eye protection. Wear breathing protection.
  	DANGER! Rotating blades pose a serious risk of injury. Keep hair, clothing, and all body parts away from the air intake or any openings. Secure hair above shoulders and behind head. Do not let your hair or clothing get drawn into the appliance. Failure to keep hair, clothing, or body parts away from air intake could result in personal injury.	 STOP	The rotating part will continuously run for several seconds after you turn off the machine.
	Immediately remove the plug from the mains if the power cable is damaged, frayed or entangled. Always keep the power cable away from heat, oil and sharp edges.		Always use table saw two handed.
	DOUBLE INSULATION – When servicing, use only identical replacement parts.		Before using, always read and understand instruction manual
	Wear hearing protection		Wear eye protection



This symbol designates that this tool is listed with U.S. requirements by CSA Testing Laboratories, Inc.
Conforms to UL62841-3-1
Certified to CAN/CSA C22.2 No. 62841-3-1:16+Upd.1

KNOW YOUR COMPACT TABLE SAW

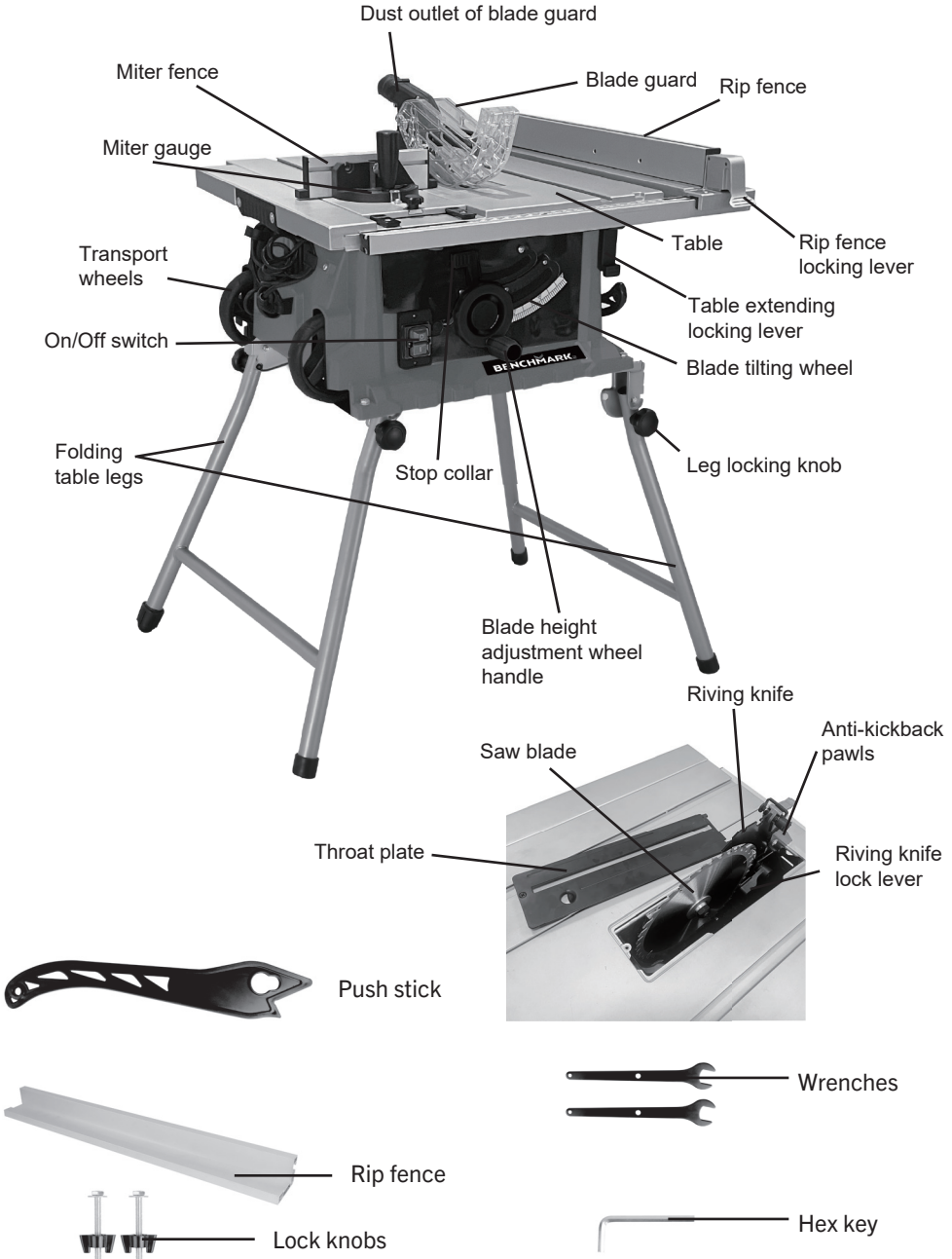

ASSEMBLY AND OPERATING

SETTING UP THE STAND

⚠ WARNING: Always unplug the saw before making any adjustments or installing accessories to prevent accidental start-up and serious injury.

The stand has three positions: standing, folding, and transporting. The legs are secured with twist leg locking knobs that lock or unlock by twisting in either direction, with a central "unlocked" position.

Standing Position:

1. Start by placing the saw on its wheels (A1). Unlock the upper legs and swing them upwards, then lock them in place (A2). Next, unlock the lower legs (see Fig.1).
2. Lift the table from the end (A3) to allow the lower leg to swing into place. Swing the leg fully into position and lock it (A4) (see Fig.2).
3. The saw features an adjustable spring leg (Fig. A5). Rotate it clockwise or counterclockwise to adjust to your desired length (A5) (see Fig.1).

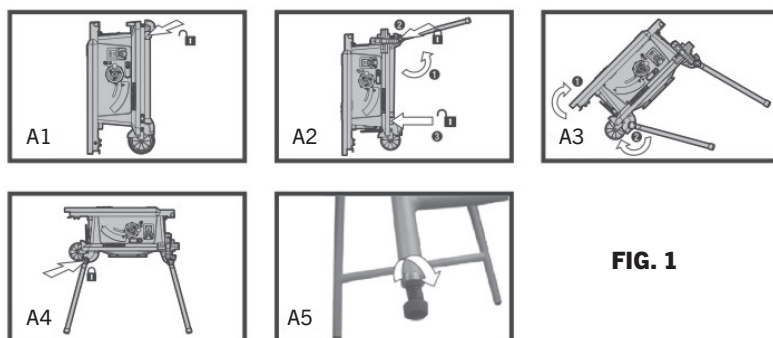

FIG. 1

FOLDING INSTRUCTIONS

Hold and support the table edge, unlock the legs at the wheel end (B1). Lower the wheels to the ground, allowing the legs to swing under (B2). Stand the table on end, fold up and lock the lower legs, unlock the upper legs (B3). Swing down the legs and lock (B4)(Fig.2).

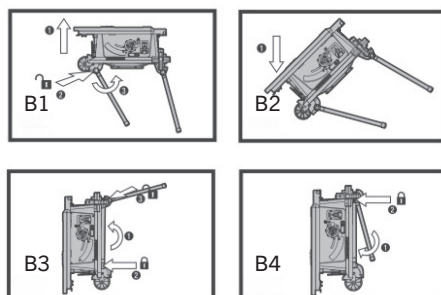

FIG. 2

TO TRANSPORT THE TABLE SAW

The upper legs may be locked in the vertical position for use as a trolley handle (Fig.3).



FIG. 3

⚠ WARNING: The stand should not rock after all of the screws have been tightened.

⚠ WARNING: The stand must be placed on a level surface.

ON/OFF SWITCH

The ON/OFF switch (1) (Fig.4) is located on the front of the table saw. Press the green ON button (2) to turn table saw On press the red OFF button (3) to turn table saw Off. This table saw is equipped with an electromechanical safety switch with line voltage interruption, in case of a power failure the table saw will need to be restarted using the switch.

RESET BUTTON(OVERLOAD PROTECTOR)

This table saw comes with an overload reset button (4) (Fig.4) (above the ON/OFF Switch). A safety mechanism stops the motor automatically due to the motor overheating or low voltage. Allow the saw to cool or plug the saw into outlet with sufficient voltage and then press the reset button to restart the table saw. If the table saw does not restart, wait 5 minutes before attempting to restart again.

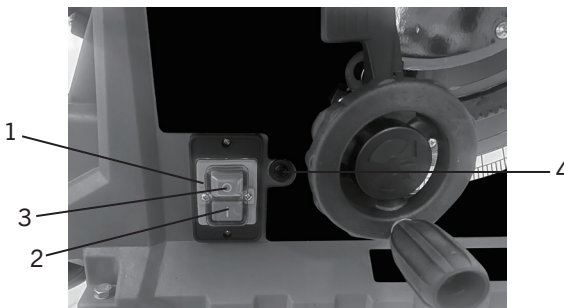

FIG. 4

ADJUSTING THE RIVING KNIFE

The riving knife (3) (Fig.5), a safety feature on a table saw, is a thin, fixed metal plate mounted behind the saw blade. It helps prevent kickback by keeping the cut pieces of wood from pinching the blade or closing in on it during a cut.

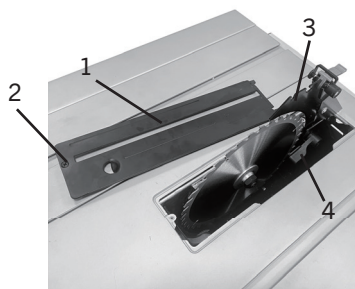

FIG. 5

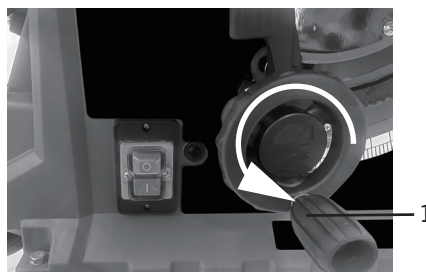
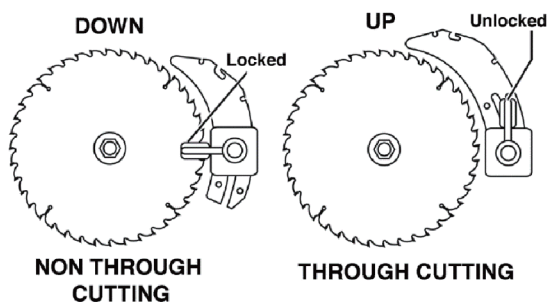

FIG. 6

1. To adjust the riving knife (3), remove the throat plate (1) (Fig.5) from the tabletop by unscrewing the pan head screw (2) and then pulling it upwards.
2. Turn the blade height adjustment wheel (1) (Fig.6) counterclockwise and raise the blade to its highest position above the table.

NOTE: This saw is shipped with the riving knife in the non-through cutting or "down" position, as shown below. The riving knife must be positioned in the through cutting or "up" position for all other operations.



4. Unlock the riving knife lock lever (4) (Fig.5) by pivoting it upwards (vertical position).
5. Push the riving knife (3) (Fig.5) towards the lock lever (4) (Fig.5) to disengage it from its positioning pins/slots.
6. Pull the riving knife (3) (Fig.5) upwards until its bottom mounting holes engage the positioning pins, and the riving knife (3) is above the saw blade.
7. Engage the lock lever (4) (Fig.5) by pivoting it downwards (horizontal position). Once secured, make sure the riving knife is perfectly aligned with the center of the blade. If not, it is most likely due to misalignment of the positioning pins, re-adjust until alignment is obtained.
8. Reinstall and secure the throat plate (1) (Fig.5) with pan head screw.

ALIGNING RIVING KNIFE

IMPORTANT: If riving knife is correctly mounted, yet it is not perfectly centered with the blade, proceed with the following adjustment.

1. Using a straight edge (1) (Fig.7), check to ensure the riving knife (3) (Fig.8) is aligned with the blade as shown.
2. If an adjustment is necessary, loosen 2 x cap screws (1) (Fig.8) that hold the throat plate (2) using the 5mm hex key (provided). Adjust the position of the riving knife (3) to the right or left until it is perfectly aligned with the blade. Retighten cap screws.

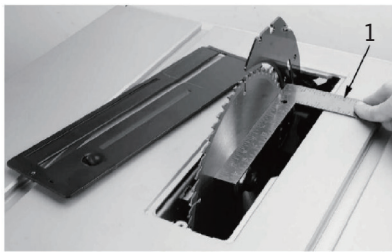

FIG. 7

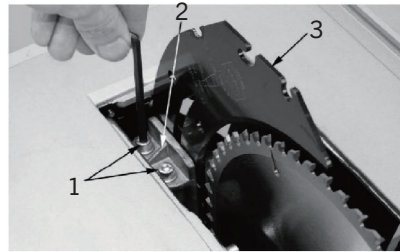

FIG. 8

MOUNTING ANTI-KICKBACK PAWLS

Press down on the pawl socket (1) to adjust the pawl to the appropriate angle, and simultaneously press down on the pawl locking pin (2). Then install the pawl in the hole (3) at the top of the riving knife, release the pawl socket and pawl lock pin, and clamp the pawl onto the riving knife (Fig.9)

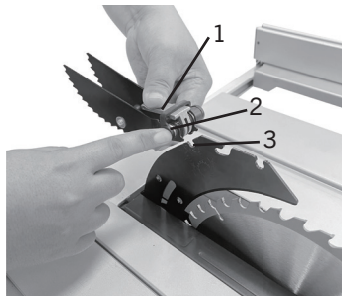

FIG. 9

MOUNTING BLADE GUARD TO RIVING KNIFE

- 1) Raise the blade to its highest position. Make sure the riving knife is in the "up" position and secured.
- 2) Make sure to reposition and secure the throat plate (1) (Fig.10) in the table top opening before installing the blade guard (3) (Fig.10).
- 3) Lower the back end shaft (2) (Fig.10) of the blade guard (3) into the rear slot (4) (Fig.10) of the riving knife as shown.

- 4) Press and hold the spring loaded button (1) (Fig.11) on the right side of the blade guard and lower blade guard so it engages in the front slot on the riving knife (5) (Fig.10).
- 5) Release the spring loaded button (1) (Fig.11) to lock the blade guard to the riving knife. Lift the blade guard up to check it is locked securely.

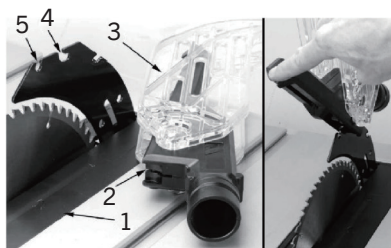

FIG. 10



FIG. 11

INSTALLING THE VACUUM HOSE (NOT INCLUDED)

Connect one end of the vacuum hose (5) to the dust outlet (1) of the blade guard, twist and push the vacuum connector to lock it in place, and connect the other end of the hose to the three-way adapter (2). Connect one end of the adapter to the fixed guard dust outlet (3), and the other end (4) to the vacuum cleaner (Fig.12)

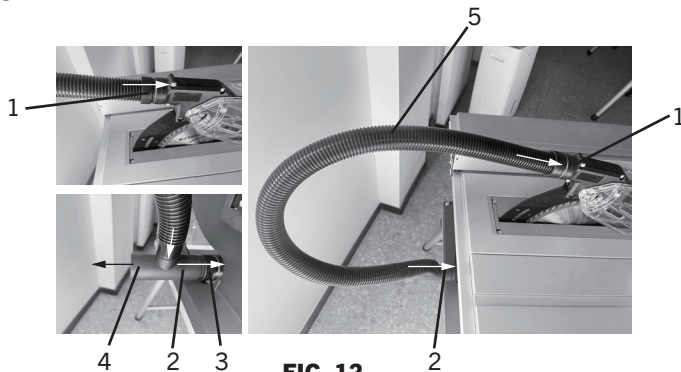

FIG. 12

MOUNTING RIP FENCE ON TABLE & ADJUSTMENTS

1. Align the front of the rip fence (1) (Fig.12) with the side of the front rail (2). Align the back end of the rip fence (1) with the side of the rear rail (3). Slide rip fence (1) onto both rails. Check to ensure the rip fence locking lever (4) is in the unlocked and "up" position and the rip fence (1) slides freely on the rails (2) &(3).
2. Lower rip fence locking lever (4) "down" to lock the rip fence (1) in place.

NOTE: To reduce the risks of kickback, the rip fence must be perfectly parallel to the blade.

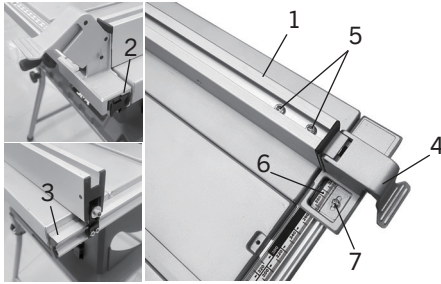

FIG. 13

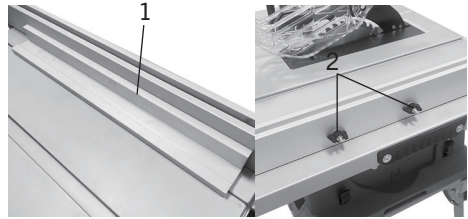

FIG. 14

INSTALLING THE ALUMINUM GUIDE

1. Unlock rip fence (1) by raising rip fence locking lever (4) (Fig.13). Loosen both cap screws (5) on top of the rip fence (1) using the 5mm hex key (provided).
2. Align the rip fence parallel with the blade and retighten both cap screws.
3. Adjust the rip fence indicator (6) to the same marking by loosening the pointer screw (7) and reposition indicator.
4. The horizontal aluminum guide (1) can be installed to left side of the rip fence in the horizontal position as shown. This aluminum guide is mainly used to safely rip thin and narrow stock, especially when cutting workpieces with the blade tilted to 45° (Fig.14).
5. Insert two long hex. bolts into the left side in the rip fence loosely and secure the hexbolts with washers and lock knobs (2). Slide the T-slot of the aluminum guide over the head of each hex bolt, once in position, tighten lock knobs (2) (Fig.14).

NOTE: It is not recommended to use the horizontal position aluminum guide (1) (Fig.14) with the extension table extended.

MOUNTING AND ADJUSTING THE MITER GAUGE

When crosscutting with the blade set at 90° or 45° to the table, the miter gauge (1) (Fig.14) can be used in either the right side or left side T-slot (2) on the table. When crosscutting with the blade tilted, use the right sided T-slot of table where the blade is tilted away from your hands and miter gauge.

1. Slide the miter gauge bar into one of the T-slots (2) in the table.
2. To adjust the miter gauge, loosen lock handle (3) and set the miter gauge (1) so the indicator (4) aligns to the desired cutting angle, then re-tighten lock handle (3) (Fig.15).
3. This miter gauge comes with an aluminum facing (5) which can be removed if desired by removing lock knob (6). (Fig.15).
4. Ensure the miter gauge is square against the saw blade. Place a square (1) (Fig.16) against the blade (2), loosen lock handle (3) and place the miter gauge against the square. Once the miter gauge is perfectly square with the blade, re-tighten lock handle (3). If the pointer (4) requires alignment, loosen screw (5) and reposition the pointer, re-tighten screw.

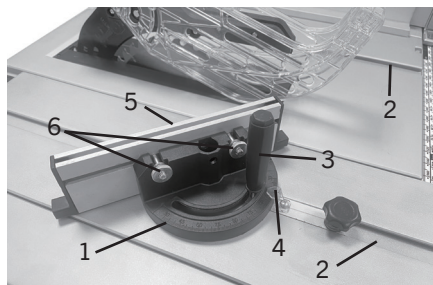

FIG. 15

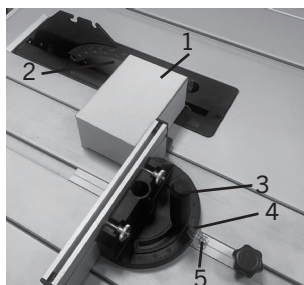

FIG. 16

ADJUSTING THE SLIDING EXTENSION TABLE

The sliding extension table allows the user to increase the length of the table for greater ripping capacity (maximum 25.6" (650 mm) rip to the right of blade). To use the extension table:

1. Unlock or remove the rip fence from the table.
2. Unlock the extension table (1) (Fig.17) by raising the table extending locking lever (3), slide the extension to the desired width. Use the scale on the front rail (2) when a specific width is desired, or measure the distance from the blade for precise cuts.
3. Once the extension table is in the desired position, lower the table extending locking lever (3) to secure the extension in place. The rip fence can now be reinstalled.

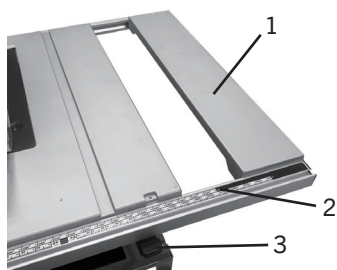

FIG. 17

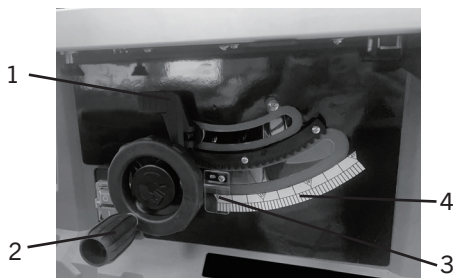

FIG. 18

ADJUSTING THE BLADE HEIGHT

The blade height should be set 1/8" to 1/4" above the workpiece to cut.

1. Turn the blade height adjustment wheel (2) (Fig.18) counterclockwise to raise the blade or clockwise to lower the blade.

ADJUSTING THE BLADE ANGLE FOR BEVELED CUTS

NOTE: A 90° cut has a 0° bevel angle and a 45° cut has a 45° bevel angle.

1. Unlock the bevel angle lock/release lever (1) (Fig.18) by pulling the lever all the way to the right.
2. Move the blade height adjustment wheel (2) to the right to adjust the blade bevel angle, use the bevel tilt angle indicator (3) and angle scale (4) as reference.
3. Once the desired bevel angle is achieved, lock the bevel angle/ lock release lever (1) by pushing the lever all the way to the left.

ADJUSTING THE BEVEL TILT ANGLE INDICATOR

If the blade is at a 90° angle and the bevel indicator (1) (Fig.20) does not indicate 0° on the scale, an adjustment can be made,

1. Place a combination square (1) (not included) (Fig.19) on the table and up against the flat portion of the blade (2).
2. Unlock the bevel angle lock/release lever (1) (Fig.18) by pulling the lever all the way to the right. Move the blade height adjustment wheel handle (2) (Fig.18) until the blade is set at a perfect 90° to the square. Lock the bevel angle lock/release lever.
3. Loosen the screw (2) (Fig.20) which secures the bevel indicator (1). Re-adjust the position of the bevel tilt angle indicator so it aligns with the 0° on the bevel scale.
4. Retighten the screw (2) (Fig.20).

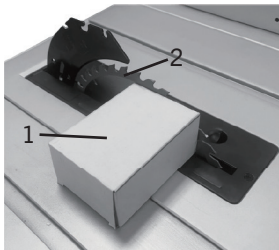

FIG. 19

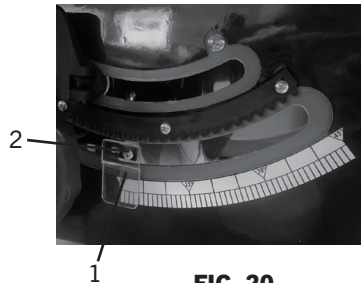

FIG. 20

INSTALLING/CHANGING BLADE

⚠ WARNING: Turn tool OFF and disconnect power cord from power source before installing/changing blade.

⚠ WARNING: Always use a 10-inch (254 mm) diameter blade that is compatible with the saw's arbor size and intended for the material being cut. Using the correct blade ensures safe operation and optimal performance.

⚠ CAUTION: To work properly, the saw blade teeth must point down toward the front of the saw. Failure to heed this instruction could cause damage to the saw blade, the saw or the workpiece.

⚠ WARNING! Make sure that the saw blade is installed to rotate in the proper direction. Do not use grinding wheels, wire brushes, or abrasive wheels on a table saw. Improper saw blade installation or use of accessories not recommended may cause serious injury.

1. Uninstall the blade guard assembly from the riving knife. Then remove the throat plate to gain access to the blade arbor.
2. Raise the blade to its highest position above the table.
3. Place the open end of one of the adjustment wrenches (1) (Fig.21) on the flat portion of the outer flange (2) to prevent the saw arbor and blade from rotating.
4. Then place the open end adjustment wrench (1) (Fig.22) on the arbor nut (2) (Fig.22) and turn the arbor nut counterclockwise, remove arbor nut and outer flange (2) (Fig.21). Refer to illustration in (Fig.23).
5. Place new blade on arbor making sure the blade teeth point downwards towards the front of the table saw.
6. Replace outside blade flange and arbor nut on arbor shaft and tighten with arbor wrenches.
7. Reinstall the table insert and blade guard assembly.

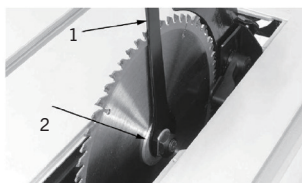

FIG. 21



FIG. 22

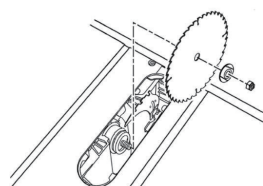

FIG. 23

SAFETY PRECAUTIONS BEFORE OPERATION

The operation of power tools involves a certain amount of hazard for the operator. Before attempting regular work practice with using scrap lumber to check settings. Read entire instruction manual and safety information before attempting a cut in the workpiece. Always pay attention to safety precautions to avoid personal injury.

PUSH STICK

A push stick is supplied with this table saw and should be used whenever possible to protect the hand while allowing good hand control of the stock as it is pushed through the cutting blade.

If the push stick becomes lost, (Fig.24) shows an illustration of the dimensions to make one. It is recommended to use a good quality plywood or solid wood, 1/2" or 3/4" thick.

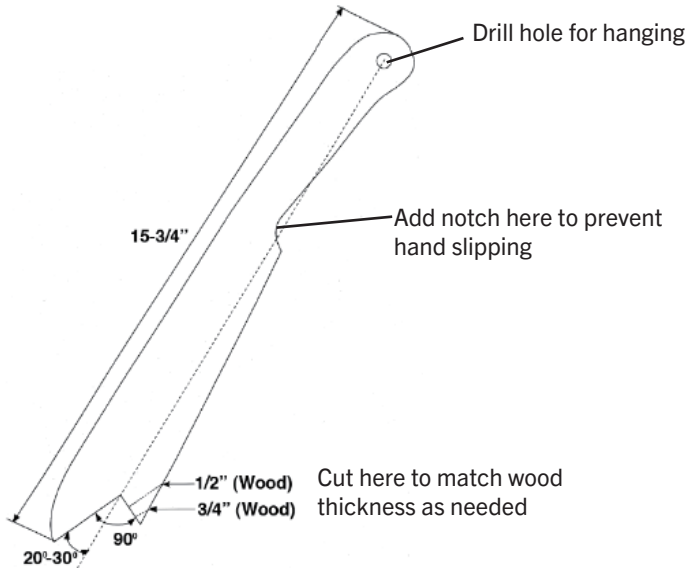

FIG. 24

MAKING A CROSS CUT

A cross cut is a cut made across the grain of the wood, typically to shorten the length of the board. It is done using the miter gauge.

1. Set up the saw: Adjust the blade height and use the miter gauge. **NEVER** use the rip fence as a cut-off gauge when crosscutting. This could cause dangerous kickback.
2. Measure and mark the cut on the wood.
3. Position the wood against the miter gauge, ensuring it's flat and aligned.
4. Adjust the miter gauge for a square or angled cut.

NOTE: The miter gauge may be used in either table T-slot, however, most operators prefer the left T-slot for average work. When bevel cutting (blade tilted), use the right side table T-slot so that it doesn't interfere with the tilted saw blade.

5. Make the cut and let the blade reach full speed before moving the workpiece into the blade. Hold the workpiece firmly with both hands on the miter gauge, and feed the workpiece slowly into the blade. If the workpiece becomes narrow or you're at risk of getting too close to the blade, use a push stick to safely push the wood through.

⚠ CAUTION: Never hang onto or touch a free piece of work. Hold the supported piece, not the free piece that is cut-off.

6. Turn off the saw and wait for the blade to stop before removing the wood.

MAKING A RIP CUT

A rip cut is a cut made with the grain of the wood to make it narrower, using the rip fence on a table saw for guidance.

⚠ WARNING: Make sure the blade guard assembly is installed and working properly to avoid possible serious injury.

⚠ CAUTION: Never stand in the line of the saw cut when ripping. Hold the work with both hands and push it along the fence and into the saw blade. The work can then be fed through the saw blade with one or two hands.

1. Set blade height. Raise the blade so it's about 1/4" to 1/2" above the top of the material.
2. Set the fence. Measure from the fence to the blade to match your desired cut width. Lock the fence.
3. Check the table extension and ensure your table extension is level with the main table and fully supports the workpiece during and after the cut.
4. Position the material and place the board flat on the table, edge against the fence, and front end just before the blade.
5. Start the saw and stand to the side of the blade, not directly behind it.
6. Let the blade reach full speed before beginning the cut.
7. Make the cut. Push the board firmly and steadily through the blade, keeping it tight to the fence. Use a push stick or block when your hand gets within 6" of the blade.
8. Let the table extension catch the off-cut or end of the board—don't lift or shift it.
9. Turn off the saw. Wait for the blade to stop completely before removing off-cuts.

⚠ CAUTION: Never hang onto or touch a free piece of work. Hold the supported piece, not the free piece that is cut-off.

MAKING A NON-THROUGH CUT

Non-through cuts can be made with the grain (ripping) or across the grain (cross cut). Non-through cuts are needed for cutting grooves or rabbets. This is the only type of cut that the blade gets covered by the workpiece and is made without the blade guard installed.

⚠ CAUTION: Ensure the blade guard is reinstalled after this type of cut is done.

1. Set blade height to the desired depth (not fully through the material).
2. Remove blade guard if necessary (common for non-through cuts).

3. Let the blade reach full speed before beginning the cut.
4. Position the workpiece using the fence and miter gauge.
5. Feed the workpiece slowly over the blade, keeping steady pressure and control.
6. Use push stick to keep hands away from the blade.

⚠ WARNING: Do not lift or remove the workpiece until the blade has come to a complete stop.

7. Turn off the saw. Wait for the blade to stop completely before removing off-cuts.
8. Reinstall blade guard when finished with non-through operations.

UNDER-TABLE STORAGE

This table saw comes with convenient under-table storage areas for loose accessories, below is a list of all components and the location of its under-table storage.

1. Rip Fence (1) (Fig. 25):
Install the rip fence upside down under the extension table, as shown.
2. Blade Guard (1) (Fig. 26):
Mount the blade guard to the bracket on the riving knife using the same installation method as noted previously.
3. Blade Adjustment Wrenches (1) (Fig. 27):
Secure both adjustment wrenches using the lock knob.
4. Push Stick (2) (Fig. 27):
Secure the push stick using the lock knob.
5. Miter Gauge (1) (Fig. 28):
Store the miter gauge in place using the two retaining clips.



FIG. 25

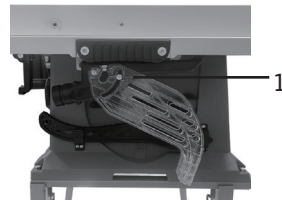

FIG. 26

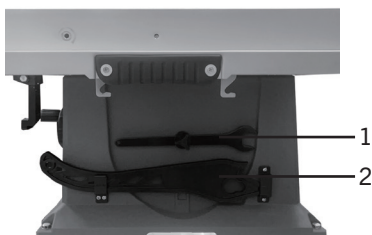

FIG. 27



FIG. 28

MAINTENANCE

⚠ WARNING: For your own safety, turn the power switch "OFF" and remove plug from power source outlet before maintaining or lubricating your saw.

Do not allow sawdust to accumulate on the saw. Frequently blow any dust that may accumulate under the saw and the motor. Clean your cutting tools with a gum and pitch remover. The cord and tool should be wiped with a dry clean cloth to prevent deterioration from oil and grease.

⚠ WARNING: Certain cleaning agents and solvents can damage plastic parts. Some of these are: gasoline, carbon tetrachloride, chlorinated cleaning solvents, ammonia and household detergents which contain ammonia. Avoiding use of these and other types of cleaning agents will minimize the possibility of damage.

⚠ WARNING: All repairs, electrical or mechanical, should be attempted only by trained repairmen. Use only identical replacement parts, any other may create a hazard. If the power cord is worn or cut, or damaged in any way, have it replaced immediately.

⚠ WARNING: When servicing, use only identical replacement parts. The use of any other part may create a hazard or cause product damage.

⚠ WARNING: DO NOT abuse power tools. Abusive practices can damage the tool and the workpiece.

⚠ WARNING: DO NOT attempt to modify tools or create accessories. Any such alteration or modification is misuse and could result in a hazardous condition leading to possible serious injury. It will also void the warranty

LUBRICATION

The table saw has sealed lubricated bearings in the motor housing and the arbor assembly, they will not require any additional lubrication.

A coat of automobile type wax applied to the table will help keep the surface clean and allow workpieces to slide more freely.

TROUBLESHOOTING

PROBLEM	SOLUTION
<p>SAW WILL NOT START</p> <ol style="list-style-type: none"> 1. Saw not plugged in. 2. Fuse blown or circuit breaker tripped. 3. Cord damaged. 	<ol style="list-style-type: none"> 1. Plug saw in. 2. Replace fuse or reset circuit breaker. 3. Have cord replaced by a certified electrician.
<p>OVERLOAD KICKS OUT FREQUENTLY</p> <ol style="list-style-type: none"> 1. The extension cord is too long or not heavy-duty enough (undersized) for the tool's power requirements. 2. Feeding stock too fast. 3. Blade in poor condition (dull, warped, gummed). 4. Blade binding due to misaligned rip fence. 5. Blade binding due to warped wood. 6. Low voltage supply/insufficient power at outlet. 	<ol style="list-style-type: none"> 1. Replace with adequate size extension cord. 2. Feed stock more slowly. 3. Clean or replace blade. 4. Check and adjust the rip fence. See rip fence instructions. 5. Select another piece of wood. 6. Contact your electrical company.
<p>DOES NOT MAKE ACCURATE 45° AND 90° RIP CUTS</p> <ol style="list-style-type: none"> 1. Tilt angle pointer not set properly. 	<ol style="list-style-type: none"> 1. Check blade with square and adjust bevel tilt angle indicator (pointer) to zero.
<p>MATERIAL PINCHES BLADE WHEN RIPPING</p> <ol style="list-style-type: none"> 1. Rip fence not aligned with blade. 2. Warped wood. 	<ol style="list-style-type: none"> 1. Check and adjust rip fence. 2. Select another piece of wood.
<p>MATERIAL BINDS ON RIVING KNIFE</p> <ol style="list-style-type: none"> 1. Riving knife not aligned correctly with blade kerf. 	<ol style="list-style-type: none"> 1. Check and align riving knife with blade kerf.
<p>SAW MAKES UNSATISFACTORY CUTS</p> <ol style="list-style-type: none"> 1. Dull blade. 2. Blade mounted backwards. 3. Gum or pitch on blade. 4. Incorrect blade for work being done. 5. Gum or pitch on table causing erratic feed. 	<ol style="list-style-type: none"> 1. Replace blade. 2. Turn blade around. 3. Remove blade and clean with turpentine, steel wool or gum and pitch remover. 4. Change the blade. 5. Clean the table.
<p>BLADE DOES NOT COME UP TO SPEED</p> <ol style="list-style-type: none"> 1. The extension cord is too long or not heavy-duty enough (undersized) for the tool's power requirements. 2. Low voltage supply/insufficient power at outlet. 	<ol style="list-style-type: none"> 1. Replace with adequate size extension cord. 2. Contact your electric company.
<p>MACHINE VIBRATES EXCESSIVELY</p> <ol style="list-style-type: none"> 1. Damaged saw blade. 2. Loose hardware. 	<ol style="list-style-type: none"> 1. Replace blade. 2. Tighten all nuts and bolts.

EXPLODED VIEW

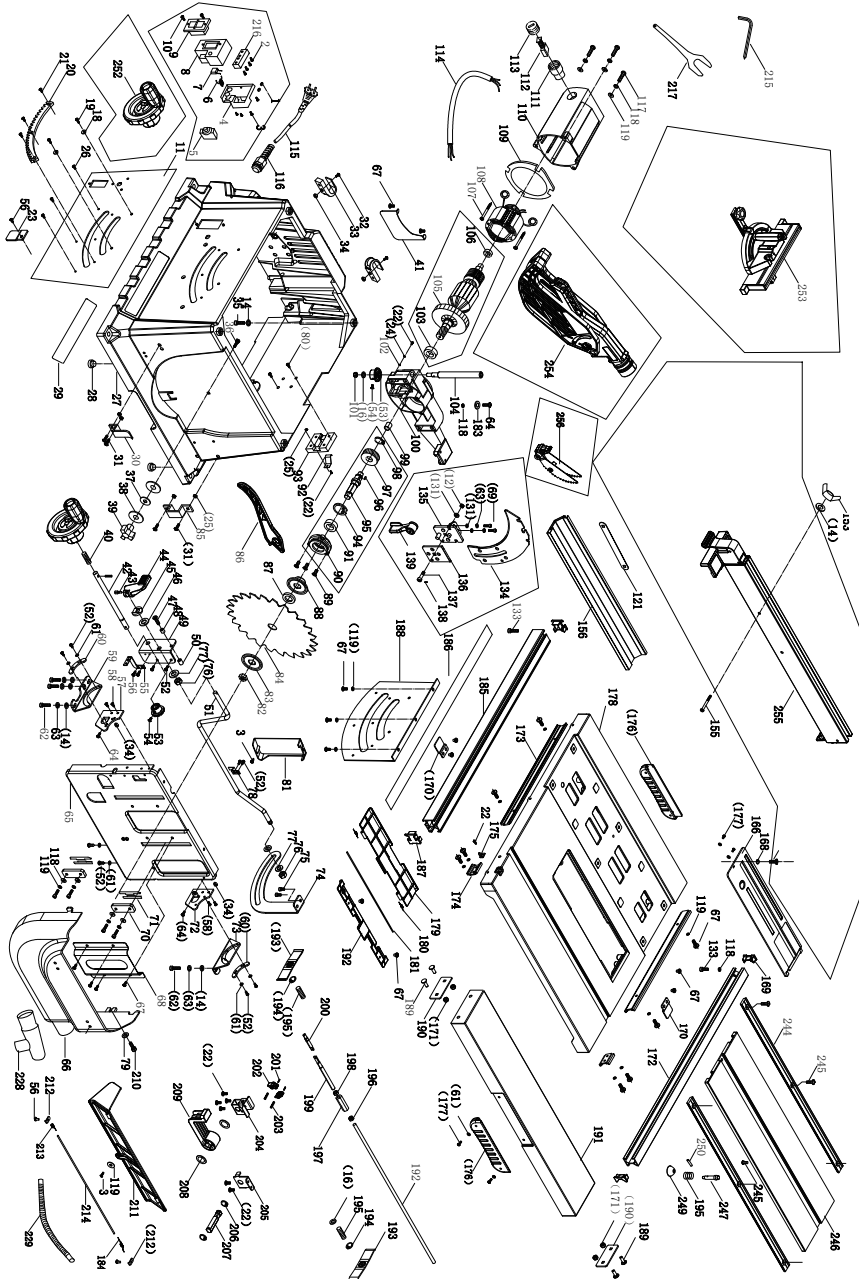

PARTS LIST

⚠ WARNING: When servicing, use only original equipment replacement parts. The use of any other parts may create a safety hazard or cause damage to the tool.

Any attempt to repair or replace electrical parts on this tool may create a safety hazard unless repairs are performed by a qualified technician. For more information, call the Toll-free Helpline, at 1-866-349-8665 Monday-Friday from 9am to 5pm Eastern Standard Time.

Always order by PART NUMBER, not by key number.

Key #	Part #	Part Name	Quantity
1	1346-631-01	Outlet	2
2	1346-631-02	Screw ST3.5 x 16	4
3	1346-631-03	Screw ST3.9 x 10	11
4	1346-631-04	Switch cover	1
5	1346-631-05	Overload protection switch (10A)	1
6	1346-631-06	Inductance	1
7	1346-631-07	Capacitance	1
8	1346-631-08	Switching Box	1
9	1346-631-09	Switch (KJD12)	1
10	1346-631-10	Screws ST3.9 X 14	2
11	1346-631-11	Labels	1
12	1346-631-12	M6 locknuts	2
13	1346-631-14	Cushion ring	18
16	1346-631-16	8 flat pad	2
17	1346-631-17	M6 Step Screw	1
18	1346-631-18	Angle Positioning Block	2
19	1346-631-19	Screws M5 x 14	2
20	1346-631-20	Rack	1
21	1346-631-21	Screws M4 x 12	3
22	1346-631-22	Screws M4 x 8	15
23	1346-631-23	Box pointer	1
24	1346-631-24	4 Ballpads	1
25	1346-631-25	M4 hexagon nut	5
26	1346-631-26	Screws M4 x 8	5
27	1346-631-27	Box body	1
28	1346-631-28	Handle	4
29	1346-631-29	Small sticker	1
30	1346-631-30	Buttons	1
31	1346-631-31	Screws M4 x 10	4
32	1346-631-32	Screws M6 x 25	2
33	1346-631-33	Cable guide bracket	2

Key #	Part #	Part Name	Quantity
34	1346-631-34	M5 locknut	4
35	1346-631-35	Screws M6 X 25	4
36	1346-631-36	Screws M6 X 25	1
37	1346-631-37	Saw blade fixed block	1
38	1346-631-38	Clear cover pads	2
39	1346-631-39	M6 Star Nut	1
40	1346-631-40	A large pressure spring	1
41	1346-631-41	Saw blade guard	1
42	1346-631-42	Rotation axis	1
43	1346-631-43	M5 Step Screw	1
44	1346-631-44	Handle	1
45	1346-631-45	Limit circle	1
46	1346-631-46	10 X 26 X 1.5 Plastic Gasket	1
47	1346-631-47	Screws M6 x 40	1
48	1346-631-48	Shaft covers	1
49	1346-631-49	Fixed block	1
50	1346-631-50	Shafts	1
51	1346-631-51	Lock rods	1
52	1346-631-52	Screws M5 x 10	13
53	1346-631-53	Gear	2
54	1346-631-54	Screws M4 x 20	2
55	1346-631-55	Needle rack	1
56	1346-631-56	Screws M4 x 6	7
57	1346-631-57	Rotation support	1
58	1346-631-58	Screws M5 x 10	4
59	1346-631-59	Rotators	1
60	1346-631-60	Rotation Limit Block	2
61	1346-631-61	Large flat cushions	8
62	1346-631-62	Screws M6 x 16	6
63	1346-631-63	6 Ballpads	6
64	1346-631-64	Screws M5 x 12	3
65	1346-631-65	Electric motor support board	1
66	1346-631-66	Dust shield	1
67	1346-631-67	Screws M5 x 8	23
68	1346-631-68	Saw blade guard	1
69	1346-631-69	Screws M6 x 20	6
70	1346-631-70	Pressure block	2
71	1346-631-71	Shim	2
72	1346-631-72	Rotation support	1
73	1346-631-73	Rotators	1
74	1346-631-74	Rotating positioning board	1
75	1346-631-75	Screws M6 x 8	2
76	1346-631-76	M10 locknut	2
77	1346-631-77	10 flat pad	3
78	1346-631-78	Limit block	1

Key #	Part #	Part Name	Quantity
79	1346-631-79	Braces	1
80	1346-631-80	ST3.9 X 12 Phillips tapping screw	2
81	1346-631-81	Endplate cover plate	1
82	1346-631-82	M14 hexagon nut	1
83	1346-631-83	Extrusion plate	1
84	1346-631-84	Alloy sawn pieces	1
85	1346-631-85	Toggle clip	1
86	1346-631-86	Push stick	1
87	1346-631-87	Saw blade positioning ring	1
88	1346-631-88	Internal pressure plate	1
89	1346-631-89	Screws Ms x 12	3
90	1346-631-90	Bearing chamber	1
91	1346-631-91	6003 bearings	1
92	1346-631-92	Spring steel sheets	1
93	1346-631-93	Angle fixed seat clips	1
94	1346-631-94	Perforated springs	1
95	1346-631-95	Output axis	1
96	1346-631-96	Flatkeys 5 X 5 X 12	1
97	1346-631-97	Large gears	1
98	1346-631-98	16 Axial springs	1
99	1346-631-99	HK1210 needle roller bearings	1
100	1346-631-100	Middle cover	1
101	1346-631-101	M8 locknut	1
102	1346-631-102	Toothed pads	1
103	1346-631-103	6202 bearings	1
104	1346-631-104	Screw	1
105	1346-631-105	Rotor	1
106	1346-631-106	629 bearings	1
107	1346-631-107	ST3.9 X 60 Phillips tapping screw	2
108	1346-631-108	Stator	1
109	1346-631-109	Ring	1
110	1346-631-110	Case	1
111	1346-631-111	Brush grip	2
112	1346-631-112	Carbon brush	2
113	1346-631-113	Brush grip cover	2
114	1346-631-114	(Electrical) Connectors	1
115	1346-631-115	Cable wire plug	1
116	1346-631-116	Cable protection sleeve	1
117	1346-631-117	Screws M5 x 30	3
118	1346-631-118	5 Ballpads	8
119	1346-631-119	5 flat pad	19
121	1346-631-121	Gasket	2
122	1346-631-122	Screws M5 x 12	2
123	1346-631-123	05 X 016 X 1.2 Flat Pad	1
123	1346-631-125	Cover	1

Key #	Part #	Part Name	Quantity
133	1346-631-133	Screws M5 x 8	2
134	1346-631-134	Dividing knife	1
135	1346-631-135	Substitute blade pressing plate 1	1
136	1346-631-136	Substitute blade pressing plate 2	1
137	1346-631-137	Clamping screw	1
138	1346-631-138	3X15 Elastic Cylindrical Pin	1
139	1346-631-139	Spare knife lock knob + top	1
166	1346-631-166	Throat plate	1
167	1346-631-167	Screws M5	1
168	1346-631-168	Cylinders	1
169	1346-631-169	Extension pole 1 end cover	2
170	1346-631-170	Limit Blocks	2
171	1346-631-171	M6 padded nut	4
172	1346-631-172	Extension pole	1
173	1346-631-173	Fixed rod (long)	2
174	1346-631-174	Fixed rod (short)	2
175	1346-631-175	Panel pointers	1
176	1346-631-176	Sideplate brace	2
177	1346-631-177	Screws M5 x 12	4
178	1346-631-178	Workbench (panels)	1
179	1346-631-179	Movement barrier	1
180	1346-631-180	Torsional spring	2
181	1346-631-181	03 X 331 Cylindrical Pin	1
182	1346-631-182	Fixed panels	1
183	1346-631-183	05 x 015 X 3 flat pad	1
184	1346-631-184	Shock spring 3	1
185	1346-631-185	Extension pole	1
186	1346-631-186	Workbench scales	1
187	1346-631-187	Extension pole end cover	2
188	1346-631-188	Box reinforcing panel	1
189	1346-631-189	Screws M6 x 16	4
190	1346-631-190	Long pressure plate	2
191	1346-631-191	Extension plate workbench solders	1
192	1346-631-192	Regulator	1
193	1346-631-193	Extension tightening sheets	2
194	1346-631-194	Snap ring	2
195	1346-631-195	Small pressure spring	3
196	1346-631-196	M8 nut (left-hand)	1
197	1346-631-197	The hexagonal adjustment nut	1
198	1346-631-198	M8 padded nut	1
199	1346-631-199	Regulator 1	1
200	1346-631-200	Regulator 2	1
201	1346-631-201	3 x 12 semi-hollow rivet with large flat head	2
202	1346-631-202	Lock block	2
203	1346-631-203	04.5 X 20 Cylindrical Pin	2

Key #	Part #	Part Name	Quantity
204	1346-631-204	Fixed block extension	1
205	1346-631-205	Fixed block extension	1
206	1346-631-206	12 axle springs	2
207	1346-631-207	Fixed rod	1
208	1346-631-208	20 X 15 x 0.5 Gasket	4
209	1346-631-209	Wrench lock	1
210	1346-631-210	M5 X 12 Hexagon Head Bolts	1
211	1346-631-211	Activity boards	1
212	1346-631-212	Rotating shaft presses	2
213	1346-631-213	Shock springs	1
214	1346-631-214	Axis of rotation	1
215	1346-631-215	Hexagonal wrench	1
216	1346-631-216	Wire sheets	1
217	1346-631-217	Open wrench	2
228	1346-631-228	T-joint	1
229	1346-631-229	Hose (1.5 m)	1
230	1346-631-230	Screws 3.9 x 16	7
244	1346-631-244	Slides	2
245	1346-631-245	Screws M6 x 8	6
246	1346-631-246	Sliding table	1
247	1346-631-247	Self-lock pin	1
249	1346-631-249	Self-lock hat	1
250	1346-631-250	03 X 16 Hollow Pin	1
251	1346-631-251	Screws M6 x 25	1
252	1346-631-252	Adjustment wheel	1
253	1346-631-253	Miter gauge	1
254	1346-631-254	Blade guard	1
255	1346-631-255	Rip fence	1
256	1346-631-256	Anti-kickback pawls	1

WARRANTY

BENCHMARK 10" COMPACT TABLE SAW

If this Benchmark tool fails due to a defect in material or workmanship within five years from the date of purchase, return it to any Home Hardware store with the original bill of sale for exchange.

This warranty covers defects in material or workmanship only. It does not cover normal wear and tear, failure due to abuse/misuse, or defects caused by careless or accidental mishandling. If this Benchmark product is used for commercial or rental purposes, this warranty does not apply.

10" COMPACT TABLE SAW



5 Year Limited Warranty on tool

BENCHMARK™
MC

BENCHMARK TOOLS CANADA
ST. JACOBS, ONTARIO N0B 2N0
© 2025 Home Hardware Stores Limited

CUSTOMER SERVICE/TECH SUPPORT
1-866-349-8665

1346-631

Made in China



* This Benchmark™ product carries a five (5) year LIMITED warranty against defects in workmanship and materials.



**READ ALL INSTRUCTIONS BEFORE FIRST USE.
KEEP THIS MANUAL FOR FUTURE REFERENCE.
KEEP AWAY FROM CHILDREN.**



**WEAR CSA APPROVED
EYE PROTECTION**



**WEAR EAR
PROTECTION**



**WEAR A
FACE MASK**