

# BENCHMARK™

## 18 GAUGE PNEUMATIC BRAD NAILER



5 Year Limited Warranty

\*Pneumatic tools that fail as a result of inconsistent oiling will void the warranty.

**READ ALL INSTRUCTIONS BEFORE FIRST USE.  
KEEP THIS MANUAL FOR FUTURE REFERENCE.  
KEEP AWAY FROM CHILDREN.**



**WEAR CSA APPROVED  
EYE PROTECTION**



**WEAR EAR  
PROTECTION**



**WEAR A  
FACE  
MASK**

## PRODUCT SPECIFICATIONS

18 Gauge Pneumatic Brad Nailer	
Magazine Capacity	100 Nails
Fastener Capacity	18 Gauge 5/8" to 2" Long
Max Pressure	120 PSI
Average Air Consumption	0.3 CFM @ 90PSI
Working Pressure	70-110 PSI
Magazine Angle	90°
Air Inlet	1/4" NPT
Recommended Hose	1/4" OR 3/8"
Weight	3.2lb (1.5 kg)

- Please note (where the 1/4" NPT connector is not already installed on the tool) your tool may be shipped with a black plastic cap installed in the air inlet. Pry the cap out prior to installing the 1/4" NPT connector.

### NEED ASSISTANCE?

Call us on our toll-free customer support line:  
1-866-349-8665 (Monday through Friday 9am – 5pm Eastern Standard Time)

- Technical questions
- Replacement parts
- Parts missing from package



**NOTE** these instructions pertain to the tool only. Please refer to your compressor operator's manual and follow the manufacturer's instructions.

**TABLE OF CONTENTS**

Product Specifications..... 1  
Table of Contents..... 2  
Safety Guidelines..... 3-6  
Symbols..... 6  
Tool Specific Warnings..... 7  
Know your Pneumatic Brad Nailer..... 8  
Assembly and Operating ..... 9-15  
Maintenance ..... 16-18  
Exploded View ..... 19  
Parts List ..... 20-22  
Warranty..... 23

## SAFETY GUIDELINES

### **WARNING:**

This manual contains information that relates to PROTECTING PERSONAL SAFETY and PREVENTING EQUIPMENT PROBLEMS. It is very important to read this manual carefully and understand it thoroughly before using the product. The symbols listed below are used to indicate this information.



### **DANGER!**

Potential hazard that will result in serious injury or loss of life.



### **WARNING!**

Potential hazard that could result in serious injury or loss of life.









### **CAUTION!**

Potential hazard that may result in moderate injury or damage to equipment.

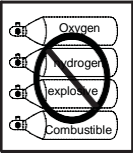
**Note** - The word " Note " is used to inform the reader of something he / she needs to know about the tool.

### **PERSONAL SAFETY**

These precautions are intended for the personal safety of the user and others working with the user. Please take time to read and understand them.

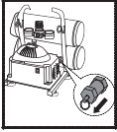
SYMBOL	MEANING
	<p><b>Do not use oxygen or any other combustible or bottled gas to power air-powered tools.</b> Failure to observe this warning can cause explosion and serious personal injury or death.</p> <p>Use only the compressed air to power the air-powered tools. Use a minimum of 25' (7.6 m) of hose to connect the tool to the compressor. Failure to comply will result in serious injury or loss of life.</p> 
	<p><b>Risk of electric shock:</b> Do not expose a compressor to rain. Store it indoors. Disconnect the compressor from power source before servicing. Compressor must be grounded. Do not use grounding adaptors.</p>
	<p><b>Risk of personal injury:</b> Do not direct compressed air from the air hose towards the user or other personnel.</p>
	<p><b>Risk for inhalation:</b> Never directly inhale the air produced by the compressor.</p>
	<p><b>Risk of bursting:</b> Do not adjust the pressure switch or safety valve for any reason. They have been preset at the factory for this compressor's maximum pressure. Tampering with the pressure switch or the safety valve may cause personal injury or property damage.</p>
	<p><b>Risk of burns.</b> The pump and the manifold generate high temperatures. In order to avoid burns or other injuries, do not touch the pump, the manifold, or the transfer tube while the compressor is running. Allow the parts to cool down before handling or servicing. Keep children away from the compressor at all times.</p>
	<p><b>Risk of bursting:</b> Make sure the regulator is adjusted so that the compressor outlet pressure is set lower than the maximum operating pressure of the tool. Before starting the compressor, pull the ring on the safety valve to make sure the valve moves freely. Drain water from tank after each use. Do not weld or repair tank. Relieve all pressure in the hose before removing or attaching accessories.</p> 

## DANGER!



- **Keep children away** from the work area. Do not allow children to handle power tools.
- Do not use this tool in the presence of flammable liquids or gases. Sparks may be created during use. Ensure all connections are secure.
- **Keep air hose away** from heat, oil, and sharp edges. Check air hose for wear before each use and ensure that all connections are proper.
- **Always ensure that the workpiece is firmly secured** leaving both hands free to control the tool.
- Always ensure that the tool has stopped before putting it down after use, for safety purposes and to prevent possible damage to the tool/user.
- **Keep proper footing at all times in order to ensure correct balance.**
- Always assume the tool is loaded with nails.
- Do not point the tool toward yourself or others.

## WARNING!



- **Do not allow unskilled or untrained individuals to operate the tool.**
- **Do not use the tool for any task other than that it is designed to perform.**
- **Keep hands and other parts of the body away from the firing head during use.** Keep hands, feet, and all other parts of the body at least 8" (20 cm) away from the firing head. Nails or objects in the workpiece can cause serious injury if they are deflected by the workpiece or if they are driven away from the point of entry.
- **Do not overload the tool. Allow the tool to operate at its optimum speed for maximum efficiency.**
- **Locate the compressor in a well-ventilated area** for cooling, and a minimum of 12" (31 cm) away from the nearest wall.
- **Protect the air hose and the power cord from damage and puncture. Inspect them for weak or worn spots every week and replace them if necessary.**
- **Always wear hearing protection** when using the air compressor. Failure to do so may result in hearing loss.
- **Do not carry the compressor while it is running.**
- **Do not operate the compressor if it is not in a stable position.**
- **Do not operate the compressor on a rooftop or an elevated position** that could allow the unit to fall or be tipped over.
- **Always replace a damaged gauge** before operating the unit again.
- Do not connect the tool to a compressed air source with a pressure output that is higher than 120 PSI.

## CAUTION!



- **Always ensure that the tool has stopped before connecting to the air supply.**
- **Do not wear watches, rings, bracelets, or loose clothing** when using any air-powered tool.
- **Do not overload the tool.** Allow the tool to operate at its optimum speed for maximum efficiency.
- Do not use a tool that is leaking air, that has missing or damaged parts, or that requires repairs. **Verify that all screws are securely tightened.**
- For optimal safety and tool performance, **inspect the tool daily** in order to ensure free movement of the trigger, safety mechanisms, and springs.
- **Always keep your air tool clean and lubricated.** Daily lubrication is essential to avoid internal corrosion and possible failures.
- **Ensure the floor is not slippery** and wear non-slip shoes. Floors should be kept clean and clear.
- **Always follow all workshop safety rules, regulations, and conditions** when using the tool.
- **Carry the tool by the handle only,** keeping fingers away from the trigger. Do not carry the tool by the hose, magazine, or any other parts.
- **Do not use the tool near or below freezing point,** as doing so may cause tool failure.
- **Do not store the tool in a freezing environment** to prevent ice formation on the tools operating valves, as doing so may cause tool failure.
- **Handling and storage of oil:** Use with adequate ventilation. Avoid contact of oil with eyes, skin, and clothing. Avoid breathing spray or mist. Store in a tightly closed container in a cool, dry, well-ventilated area free from incompatible substances.

- **Tripping Risk.** The air hose can become a tripping hazard when used in the work area. Use caution when moving around the work area.

## CAUTION!



- **Disconnect tool from the air supply and turn off the compressor** before performing any maintenance or changing accessories, when clearing a jammed fastener, when the tool is not in use, when it is being handed to another person, and when it is left unattended. Failure to comply may result in moderate to fatal injury or damage to equipment.

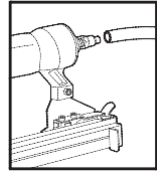

- **Use safety goggles and ear protection:** Wear safety glasses with side shields when operating the tool/compressor and verify that others in the work area are also wearing safety glasses. Safety glasses must conform to American National Standards Institute (ANSI Z87. 1) requirements and must provide protection from flying particles from the front and the sides. Air-powered tools are loud, and the sound can cause hearing damage. Always wear ear protection to prevent hearing damage and loss. Failure to comply may result in moderate injury.

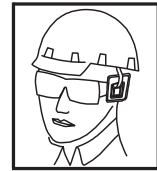

**Note:** Recycle unwanted materials rather than disposing of them as waste. Sort the tools, hoses, and packaging in specific categories and take to the local recycling center or dispose of in an environmentally safe way.

## SYMBOLS

**! WARNING:** Some of the following symbols may appear on the tool. Study these symbols and learn their meaning. Proper interpretation of these symbols will allow for more efficient and safer operation of this tool.



**Read operator's manual:** To reduce the risk of injury , user must read and understand operator's manual before using this product.



**Risk to hearing:** Always wear ear protection using this tool. when Failure to do so may result In hearing loss.



**Eye protection:** Always wear safety goggles, safety glasses with side shields, or a full-face shield when operating this product.

## **TOOL SPECIFIC WARNINGS**

- Keep hands and other parts of the body away from the firing head during use. Keep hands, feet, and all other parts of the body at least 8" (20 cm) away from the firing head. Nails or objects in the workpiece can cause serious injury if they are deflected by the workpiece or if they are driven away from the point of entry.
- Do not overload the tool. Allow the tool to operate at its optimum speed for maximum efficiency.
- Disconnect the tool from the air supply and turn off the compressor before performing any maintenance, loading, or changing nails, when the tool is not in use, when it is being handed to another person, when it is left unattended.
- Failure to comply may result in injury or damage to the equipment.
- Do not keep the tool pressed while loading fasteners.
- Do not disconnect or reconnect the air hose with the tool pressed or with a fastener in the guide. The tool may fire when it is reconnected to the air supply.
- Do not drive a fastener on top of a fastener. The fastener may ricochet, causing serious personal injury.
- Use only fasteners of the proper size and gauge as specified in this manual.
- Do not drive fasteners close to the edge of the workpiece. The workpiece may split which could allow the fastener to fly free or ricochet.

**KNOW YOUR 18 GAUGE BRAD NAILER**

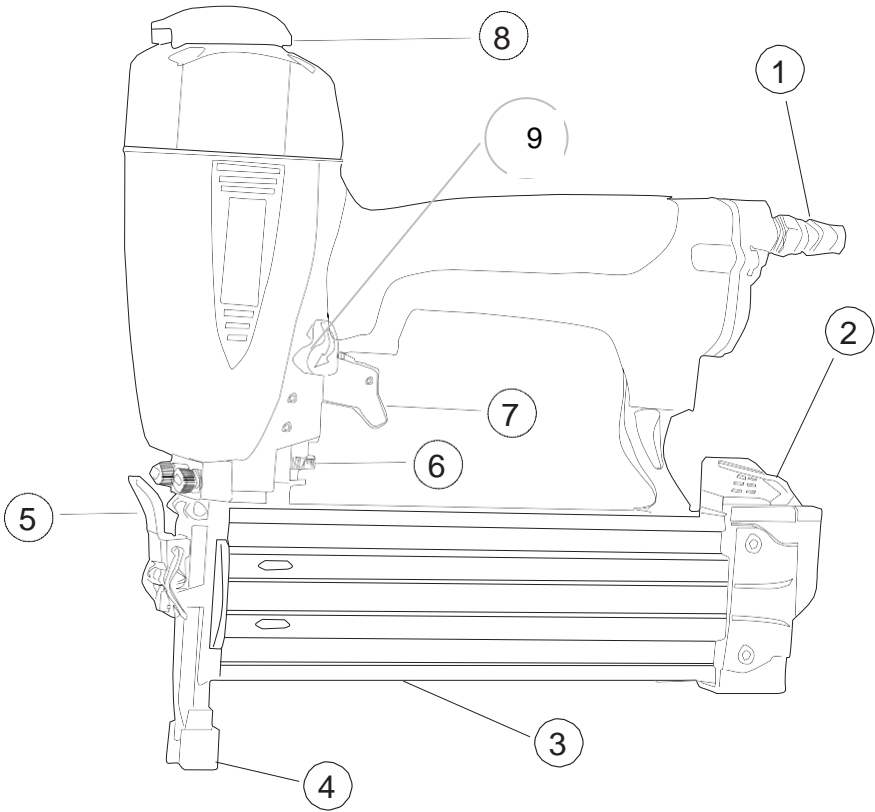

No.	Description	No.	Description
1	Air inlet plug	6	Depth adjustment dial
2	Magazine latch	7	Trigger
3	Magazine	8	Air exhaust deflector
4	Safety tip	9	Mode selection switch
5	Quick nail extraction lever		

## ASSEMBLY AND OPERATING

The 18 Gauge Pneumatic Brad Nailer delivers superior power - easily driving 2" brad nails through solid oak. Tool-free depth adjustment makes it easy to work with various dimensions of trim and molding. The super-narrow tool body and nose make it easy to get precise positioning in corners and tight spots. Handles fasteners from 5/8" to 2" long.

## COMPATIBLE COMPRESSORS GUIDELINES FOR PROPER USE AND OPERATION

Be sure to use a proper air compressor with air-powered tools. The compressor should be able to supply a minimal air delivery of 0.3 CFM @ 90 PSI to ensure the compressor can run continuously with the tool.

Air Compressor Size and Power	1/3–1 1/3 HP	1 1/2–2 HP	2+ HP
2–6 Gallons	Light-duty and Intermittent use	Light-duty and Intermittent use	Light-duty and Intermittent use
8-11 Gallons	Light-duty and Intermittent use	Medium-duty and Intermittent use	Medium-duty and Intermittent use
15+ Gallons	Medium-duty and Intermittent use	Heavy-duty and Continuous use	Heavy-duty and Continuous use

Wood Density	Nail Size	Compressor Air Pressure
>0.6 g/cm <sup>3</sup>	<1 1/4" (32 mm) brad nails	90 PSI (6.3 bar)
	≥1 1/4" (32 mm) brad nails	100 PSI (7 bar)
≤0.6 g/cm <sup>3</sup>	<1 1/4" (32 mm) brad nails	70 PSI (4.8 bar)
	≥1 1/4" (32 mm) brad nails	90 PSI (6.3 bar)

**AIR SYSTEM**

Always use clean, dry, regulated, compressed air at 4.8 to 7.5 bar (70 to 110 PSI)  
 Do not exceed the maximum or minimum pressures. Operating the tool at the wrong pressure (too low or too high) will cause excessive noise or rapid wear of tool.

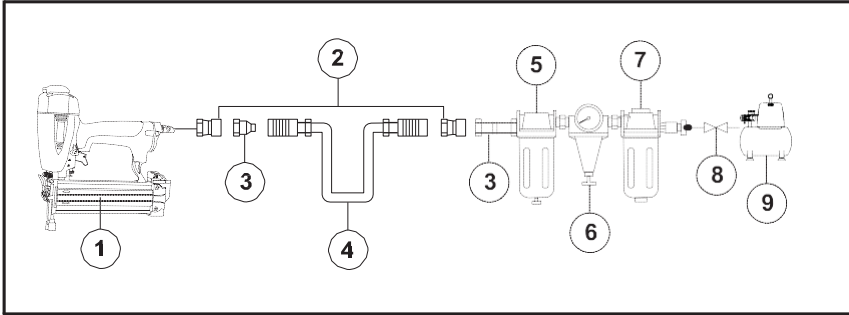

No.	Description	No.	Description
1	18 Gauge Air Brad Nailer	6	Regulator 0-110 PSI (0 to 7.5 bar)
2	Quick connector	7	Filter
3	Quick coupler	8	Cut-off valve
4	Air hose	9	Air compressor
5	Lubricator		

**⚠ WARNING** The use of any other types of fasteners will cause the tool to jam. Failure to comply could lead to serious injury or loss of life.

It is recommended that a filter-regulator-lubricator is used and located as close to the tool as possible.

If a filter-regulator-lubricator is not installed, pneumatic tools require 4-6 drops of pneumatic oil prior to and after each use. Before storing, run the oiled pneumatic tool up to 10 seconds to ensure oil contact with internal components. Repeat oiling after 2 hours of continuous use.



**REGULAR OILING IS CRITICAL FOR ONGOING TOOL PERFORMANCE**

Pneumatic tools require consistent lubrication for reliable, peak performance. Regular oiling will coat and protect the tool's internal components while breaking down deposits to ensure smooth starts and stops. Inconsistent oiling will expel out through the exhaust and O-rings will dry out. This will increase friction and reduce performance, leading to early tool failure.

Regular oiling assists in the following:

- Remove build-up on components
- Prevent rust build-up
- Ensure free movement of parts
- Create smooth starts and stops
- Prevent moisture build-up
- Remove sludge and calcium deposits

Prevent O-ring breakdown

Mineral oil that contains anti-foaming and anti-gumming additives work best in pneumatic tools.

If a filter-regulator-lubricator is installed, keep the air filter clean. A dirty filter will reduce the air pressure to the tool, which will cause reduction in power, efficiency, and general performance.

For optimal performance, install a quick coupler in the hose, if applicable.

Verify that all of the connections in the air supply system are sealed in order to prevent air from leaking.

## Pneumatic tools

### Read this Instruction Manual carefully before using the tool

Read and follow all the safety instructions at the beginning of this manual. Inspect the air-powered tool prior to each use in order to:

-Ensure that the proper power source is being used.

-Verify that the tool is in proper working order.

-Verify that the air pressure level (s) are properly set on the air compressor.

Do not use the tool if it is not in proper working order.

Do not use oxygen, CO<sub>2</sub> (carbon dioxide) or any other combustible, or bottled gas to power this tool.

Do not use this tool in the presence of any flammable liquids or gases.

Keep hands and other parts of the body away from the firing head during use.

Do not point the tool towards the operator or other people.

Never attempt to clear a jammed fastener while the air hose is connected.

Do not drive a fastener on top of an existing fastener. Failure to comply could lead to serious injury or death.

## ACCEPTABLE NAILS

Length: 5/8 - 2" (15 to 50 mm)

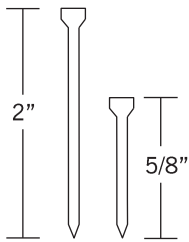

## NAIL TYPE ICON

These icons are used to select the proper nails for this specific nailer.



## Loading nails



### WARNING!

- Disconnect the tool from the compressed air source before loading nails.
- Do not point the tool towards the operator or other people while changing nails.
- Do not hold the tool with the trigger pressed while changing nails. Failure to comply will lead to serious injury or death.

1. Disconnect the tool (1) from the air supply (2).

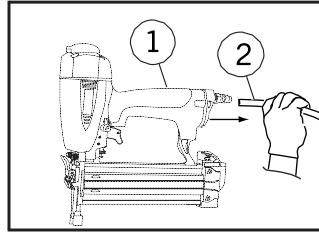

2. Hold the Brad Nailer firmly with one hand, and use the other hand to press the latch (1) on the magazine (2) and slide it back.

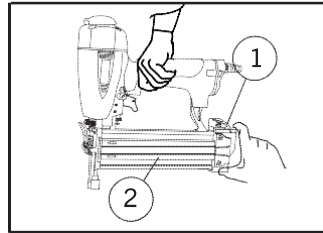

3. Insert a strip of nails (1) into the magazine. After ensuring that the points of the nails are facing down, close the magazine.

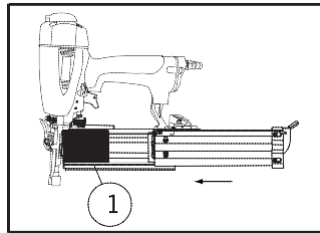

4. Plug in compressor, turn it on, set the pressure regulator to 90 PSI, attach one end of the air hose to the compressor and the other end of the air hose (2) to the tool (1). Use plumber's tape to prevent air leaks.

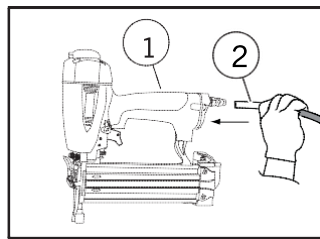

5. Test the driving depth of the tool against a sample piece of wood by pressing the trigger (1) before working on the workpiece. If the nails are being driven too deep or not deep enough, adjust the regulator in the air supply in order to provide more or less air pressure, as required.

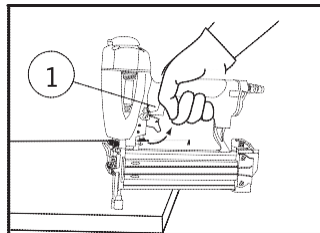

## Fasteners depth adjustment



### WARNING!

- The safety tip must be in contact with the workpiece before activating the tool.
- Do not operate the tool if the nails are not loaded, as doing so may damage the tool.
- Do not fire nails into the air, as doing so may cause injury to the operators or others, apart from damaging the tool.
- Load the correct type of nails only. Failure to comply could lead to serious injury or loss of life.

The Brad Nailer has a depth adjustment dial below the trigger to adjust the firing depth of the fasteners.

Note: Refer to the graphic imprinted below the trigger and adjust the firing depth accordingly.

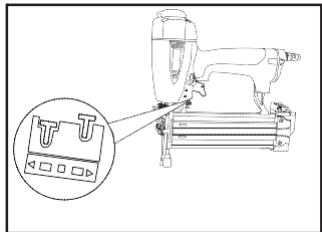

## DECREASING FASTENER DEPTH

Turn the depth adjustment dial counterclockwise (with the discharge area of the tool facing away from the operator).

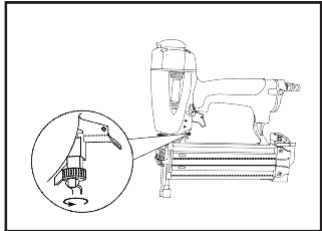

## INCREASING FASTENER DEPTH

Turn the depth adjustment dial clockwise (with the discharge area of the tool facing away from the operator).

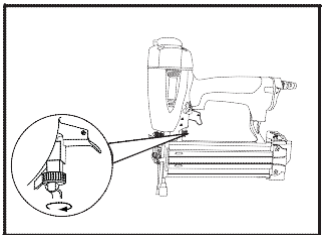

## MODE SELECTION SWITCH

### Firing modes

The Brad Nailer has two firing modes: **Single-Sequential actuation** for single firing, or **Contact / bump actuation** for repetitive, fast firing of nails. You may switch between these two modes simply by adjusting the Mode Selection Switch on the tool. For single sequential actuation mode, the selector switch must be positioned toward the back of the tool (toward the single nail icon on the tool). For repetitive firing, also known as contact or bump mode, the mode selector switch must be positioned toward the front of the tool (toward the multiple nail icon on the tool).

**Ensure the switch is positioned either fully in single sequential or contact/bump mode, otherwise, if switch is in-between the tool will not function properly.**

### **SINGLE SEQUENTIAL ACTUATION MODE**

**The single sequential actuation mechanism is for use where precise fastener placement is desired. The single sequential actuation mechanism may reduce the possibility of bodily injury to you or others in the work area compared to the contact/bump actuation mechanism. This is because it is less likely to drive an unwanted nail if you keep the trigger pulled and accidentally bump the push lever against yourself or others. The single sequential actuation mechanism may also reduce the speed of operation compared to the contact/bump actuation mechanism. The single sequential actuation mechanism is recommended to inexperienced users.**

1. Set switch on tool (toward back of tool) to single sequential actuation mode.
2. Position the nose of the tool on the workpiece with your finger off the trigger.
3. Depress the push lever on the firing head of the tool firmly against the workpiece until it is completely depressed.
4. Pull the trigger to drive a nail.
5. Remove finger from the trigger.
6. To continue nailing in a separate location, move the nailer along the wood, repeating steps 2-5 as required.

### **CONTACT OR BUMP MODE**

**\* This mode is suitable when less precise nail placement is required. It allows the user to work more quickly.** Since nails can be actuated without removing the finger from the trigger, this is a less controlled mode, suitable for more experienced users.

1. Set switch on tool (toward the front of tool) to contact or bump mode.
2. Press and hold the trigger while operating in this mode. Each time the firing head contacts a workpiece, a nail is actuated (fired). Lift the nailer and locate it at the site for the next nail. Move the nailer along the workpiece with a bouncing motion. Each depression of the push lever on the firing head of the tool will drive a nail. As soon as the desired number of nails have been driven, remove finger from the trigger.
3. This process can be repeated until the trigger is released. Extreme care should be taken because a nail will be driven when the firing head contacts any surface.

## Clearing a jammed nail

To clear a jammed nail

- Disconnect the tool from the air supply line.
- Remove the non-jammed nails that are stored in the tool's magazine.
- Operate the magazine latch and slide the pusher back to open the magazine for checking the jammed nails.
- Use pliers or any appropriate tool to remove the jammed nails.
- If the nail is jammed in the "firing" location, pull the Quick Nail Extraction lever away from the tool to access and remove the jammed nail.
- Close the magazine cover and slide the pusher to its original position.
- Reload the nails into the tool magazine.
- Reconnect the air supply line to the tool's air inlet.
- Test fire 3 to 5 nails into a piece of scrap wood in order to ensure a proper operation.

**Storage**

- When the tool is stored for longer periods of time, apply an ample amount of lubrication before storing.
- Run the tool for approximately 30 seconds after lubricating, in order to ensure that the lubrication is uniformly distributed throughout the tool.
- Store the tool in a clean and dry environment.

**Maintenance**

**Note:** Do not store the tool anywhere temperatures will fall below freezing.



**DANGER!** Disconnect the tool from the air compressor before maintenance/service, adjusting, cleaning jams, reloading, and when it is not in use.  
Repairs must be performed by a qualified service technician only.  
Failure to comply will lead to serious injury or loss of life.

Please read and follow all instructions carefully.  
Please check the tool before each use.

MAINTENANCE REQUIRED	DESCRIPTION	TOOLS OR MATERIALS REQUIRED	MAXIMUM SERVICE INTERVAL		
			Each use or every 2 hrs.	Monthly	As needed
General inspection - free movement	Trigger, spring,	None	X		
In-depth inspection	Worn or broken parts			X	X
Replace worn or broken parts					X
Lubrication	See below	Pneumatic tool oil	X		

Lubrication: If tool and the compressor are not equipped with an in-line lubrication system, place up to 6 drops of pneumatic tool oil into the air inlet before each use or after every 2 hours of continuous use, depending on the characteristics of the workpiece.

Air-operated tools must be inspected periodically ,and worn or broken parts must be replaced in order to keep tools operating safely and efficiency.

Inspect and replace worn or damaged o-rings , seals ,etc. Tighten all screws and caps frequently in order to help prevent personal injury.

Inspect the trigger, spring, and the safety mechanism for free movement on a regular basis in order to ensure that the safety system is fully functional. Verity that no part is loose or missing and that no parts are sticking or jammed.

Keep the magazine and the safety tip of the tool clean and free of any dirt or abrasive particles.

## Troubleshooting

**⚠ DANGER:** If any of the following symptoms appear while the tool is in use, turn it off and disconnect it from the air supply immediately. Failure to comply will lead to serious injury or loss of life.

Disconnect the tool from the air supply before making any adjustments. Repairs must be performed by a qualified service technician only.

The following chart lists common operating system issues and solutions. Please read it carefully and follow all instructions carefully.

Problem	Possible causes	Solutions
Air leakage at the top of the tool or in the trigger area.	<ol style="list-style-type: none"> <li>1.O-rings in the trigger valve are damaged.</li> <li>2.The trigger valve heads are damaged.</li> <li>3.Trigger valve stem, seal, or O-rings are damaged.</li> </ol>	<ol style="list-style-type: none"> <li>1. Inspect and replace the O-ring.</li> <li>2. Inspect and replace trigger valve heads.</li> <li>3. Inspect and replace the trigger valve stem, seal, or O-ring</li> </ol>
Air leakage near the bottom of the tool.	<ol style="list-style-type: none"> <li>1.The screws are loose.</li> <li>2.The O-rings or the bumper are worn or damaged.</li> </ol>	<ol style="list-style-type: none"> <li>1. Tighten the screws.</li> <li>2. Inspect and replace the O-rings or the bumper.</li> </ol>
Air leakage between the bottom and the cylinder cap.	<ol style="list-style-type: none"> <li>1.The screws are loose.</li> <li>2.The O-rings or the seals are worn or damaged.</li> </ol>	<ol style="list-style-type: none"> <li>1. Tighten the screws.</li> <li>2. Inspect and replace the O-rings or the seals.</li> </ol>

<b>Problem</b>	<b>Possible causes</b>	<b>Solutions</b>
The nails are being driven too deep.	<ol style="list-style-type: none"> <li>1. The bumper is worn.</li> <li>2. The air pressure is too high.</li> <li>3. The depth adjustment knob is not adjusted properly.</li> </ol>	<ol style="list-style-type: none"> <li>1. Replace the bumper.</li> <li>2. Adjust the air pressure.</li> <li>3. Adjust the depth setting by turning the depth adjustment knob counterclockwise (see section "Adjusting nail depth" for more detailed instructions).</li> </ol>
The tool does not operate properly - it does not drive the nails or operates sluggishly.	<ol style="list-style-type: none"> <li>1. The air supply is inadequate.</li> <li>2. Lubrication is inadequate.</li> <li>3. The O-rings or seals are worn or damaged.</li> <li>4. The exhaust deflector in the cylinder head is blocked.</li> </ol>	<ol style="list-style-type: none"> <li>1. Verify that the air supply is adequate.</li> <li>2. Pour up to 6 drops of oil into the air inlet.</li> <li>3. Inspect and replace O-rings or seals.</li> <li>4. Replace the damaged internal parts.</li> </ol>
The tool skips nails.	<ol style="list-style-type: none"> <li>1. The bumper is worn, or the spring is damaged.</li> <li>2. There is dirt in the front plate.</li> <li>3. Nails cannot move freely in the magazine due to dirt or wear.</li> <li>4. The O-ring on the piston is worn or dry or lubrication is insufficient.</li> <li>5. The cylinder cover seal is leaking.</li> </ol>	<ol style="list-style-type: none"> <li>1. Replace the bumper or spring.</li> <li>2. Clean the drive channel on the front plate.</li> <li>3. Clean the magazine.</li> <li>4. Replace the O-ring.</li> <li>5. Replace the sealing washer.</li> </ol>
The tool jams.	<ol style="list-style-type: none"> <li>1. Improper nails are used, or nails are damaged.</li> <li>2. The driver guide is damaged or worn.</li> <li>3. The magazine screw is loose.</li> <li>4. There is dirt in magazine.</li> </ol>	<ol style="list-style-type: none"> <li>1. Use proper nails. (See section "Clearing a jammed nail.")</li> <li>2. Inspect and replace the driver.</li> <li>3. Tighten the magazine.</li> <li>4. Open and clean the magazine.</li> </ol>

## EXPLODED VIEW

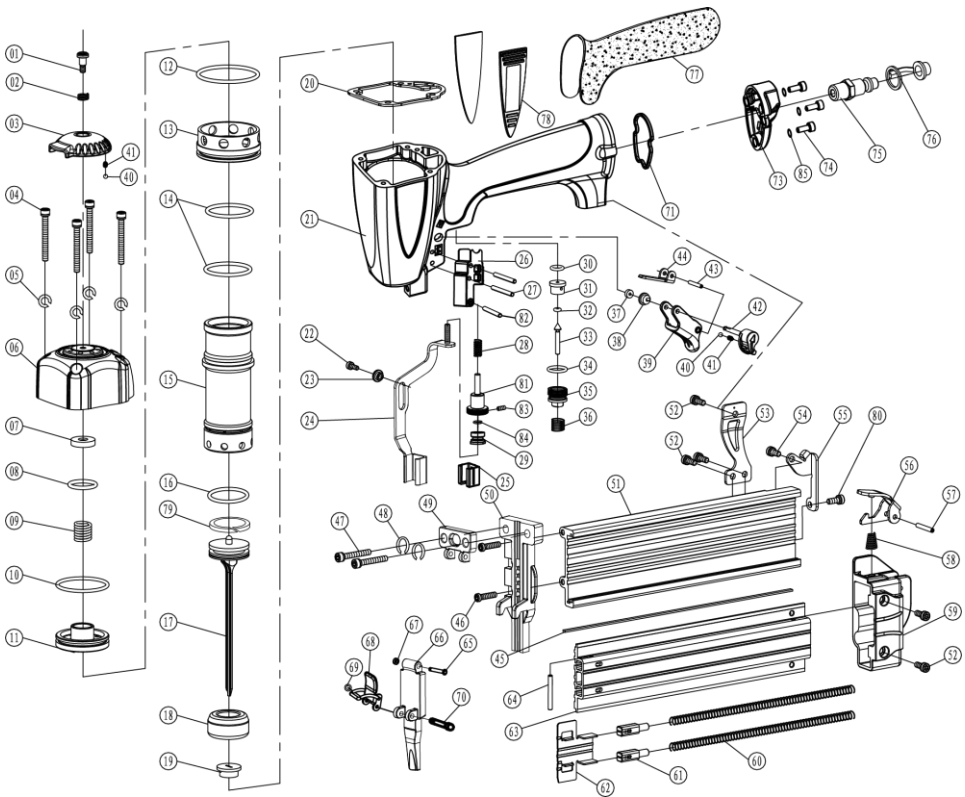

## PARTS LIST

**⚠ WARNING** When servicing, use only original equipment replacement parts. The use of any other parts may create a safety hazard or cause damage to the tool. Any attempt to repair or replace electrical parts on this nailer may create a safety hazard unless repairs are performed by a qualified technician. For more information, call the Toll-free Helpline, at 1-866-349-8665.

**Always order by PART NUMBER, not by key number.**

Key#	Part #	Part Name	Qty
1	1282-204-001	Deflector Bolt	1
2	1282-204-002	Deflector Spring	1
3	1282-204-003	Air Deflector	1
4	1282-204-004	Bolt M4 × 35	4
5	1282-204-005	Spring Washer	4
6	1282-204-006	Cylinder Cover	1
7	1282-204-007	Sealing Washer	1
8	1282-204-008	O-ring 18 x 2.65	1
9	1282-204-009	Compressed Spring	1
10	1282-204-010	O-ring 35.5 x 2.3	1
11	1282-204-011	Head Valve Piston	1
12	1282-204-012	O-ring 43 x 2.65	1
13	1282-204-013	Collar	1
14	1282-204-014	O-ring 31.2 x 2.5	2
15	1282-204-015	Cylinder	1
16	1282-204-016	O-ring 23.5 x 2	1
17	1282-204-017	Main piston	1
18	1282-204-018	bumper	1
19	1282-204-019	Guide Washer	1
20	1282-204-020	Sealing washer	1
21	1282-204-021	Gun Body	1
22	1282-204-022	Bolt M3 × 8	1
23	1282-204-023	Safety driver case	1
24	1282-204-024	Safety assembly	1
25	1282-204-025	Safety Nozzle	1
26	1282-204-026	Adjust Stand	1
27	1282-204-027	Pin 3 x 26	2
28	1282-204-028	Compression Spring	1
29	1282-204-029	Adjust nut	1
30	1282-204-030	Rectangle sealing ring 12.9 x 7 x 1.8	1

Key#	Part #	Part Name	Qty
31	1282-204-031	Trigger valve seat	1
32	1282-204-032	O-ring 1.7 x 2	1
33	1282-204-033	Switch Lever	1
34	1282-204-034	O-ring 11.2 x 2	1
35	1282-204-035	Trigger Valve Guide	1
36	1282-204-036	Compressed spring	1
37	1282-204-037	Pin case	1
38	1282-204-038	Clamp block	1
39	1282-204-039	Trigger	1
40	1282-204-040	Steel ball Dw=3	2
41	1282-204-041	Fixed spring	2
42	1282-204-042	Shift pole assembly	1
43	1282-204-043	Pin 2.5 x 18	1
44	1282-204-044	Safety Spacer	1
45	1282-204-045	Slice	1
46	1282-204-046	Bolt M4 x 14.7	2
47	1282-204-047	Bolt M5 x 25	2
48	1282-204-048	Spring Washer	2
49	1282-204-049	Fixed cover	1
50	1282-204-050	Driver guide	1
51	1282-204-051	Fixed magazine	1
52	1282-204-052	Bolt M4 x 8	6
53	1282-204-053	Support Seat	1
54	1282-204-054	Bolt M4 x 6	1
55	1282-204-055	Fixed Slice	1
56	1282-204-056	Fixed Lever	1
57	1282-204-057	Pin 3 x 20	1
58	1282-204-058	Compressed Spring	1
59	1282-204-059	Fixed seat	1
60	1282-204-060	Pusher compressed Spring	2
61	1282-204-061	Pusher Pipe	2
62	1282-204-062	Pusher	1
63	1282-204-063	Movable magazine	1
64	1282-204-064	Pin 3 x 30	1
65	1282-204-065	Plate pin	1
66	1282-204-066	Movable Cover	1

Key#	Part #	Part Name	Qty
67	1282-204-067	Pin case	1
68	1282-204-068	Quick Release Handle	1
69	1282-204-069	O-ring 1.9 x 1.2	1
70	1282-204-070	Spacer pin	1
71	1282-204-071	O-ring 41 x 1.6	1
72	1282-204-072	End cap	1
73	1282-204-073	End cap protection cover	1
74	1282-204-074	Bolt M4 x 14	3
75	1282-204-075	Quick coupler	1
76	1282-204-076	Coupler cover	1
77	1282-204-077	Rubber grip	1
78	1282-204-078	Rubber cushion	2
79	1282-204-079	Piston sealing washer	1

## **WARRANTY**

### **BENCHMARK WARRANTY**

If this Benchmark tool fails due to a defect in material or workmanship within five years from the date of purchase, return it to any Home Hardware store with the original bill of sale for exchange. 3-year warranty for the battery and charger. This warranty does not include expendable parts including but not limited to blades, brushes, belts, light bulbs. This warranty covers defects in material or workmanship only. It does not cover normal wear and tear, failure due to abuse/misuse, or defects caused by careless or accidental mishandling. If this Benchmark product is used for commercial or rental purposes, this warranty does not apply.

\*Pneumatic tools that fail as a result of inconsistent oiling will void the warranty.

# 18 GAUGE PNEUMATIC BRAD NAILER



5-Year Limited Warranty

\*Pneumatic tools that fail as a result of inconsistent oiling will void the warranty.

**BENCHMARK**™  
MC

**BENCHMARK TOOLS CANADA**  
ST. JACOBS, ONTARIO N0B 2N0  
© 2023 Home Hardware Stores Limited

**CUSTOMER SERVICE/TECH SUPPORT**  
1-866-349-8665

**1282-204**

Made in China



\*This Benchmark™ product carries a five (5) year LIMITED warranty against defects in workmanship and materials. See Owner's Manual for full details.

**READ ALL INSTRUCTIONS BEFORE FIRST USE.  
KEEP THIS MANUAL FOR FUTURE REFERENCE.  
KEEP AWAY FROM CHILDREN.**



**WEAR CSA APPROVED  
EYE PROTECTION**



**WEAR EAR  
PROTECTION**



**WEAR A  
FACE MASK**