

BENCHMARKTM MC

PNEUMATIC FRAMING NAILER



5 Year Limited Warranty

**READ ALL INSTRUCTIONS BEFORE FIRST USE.
KEEP THIS MANUAL FOR FUTURE REFERENCE.
KEEP AWAY FROM CHILDREN.**



**WEAR CSA APPROVED
EYE PROTECTION**



**WEAR EAR
PROTECTION**



**WEAR A
FACE MASK**

PRODUCT SPECIFICATIONS

PNEUMATIC FRAMING NAILER

Magazine capacity(QTY.)	80 PCS
Nailer	Drives Fastener Nail length: Clipped head nails: 50mm (2")-90mm (3-1/2")
Working pressure	70-110 psi (4.8-7.5 bar)
Maximum pressure	120 psi (8.3 bar)
Average air consumption	5.8 CFM @ 90PSI
Air inlet	1/4" NPT
Recommended Hose	1/4" or 3/8"
Magazine Angle	34 ^o
Weight	8.3 lb (3.8kg)

*Please note (where the 1/4" NPT connector is not already installed on the tool) your tool may be shipped with a black plastic cap installed in the air inlet. Pry the cap out prior to installing the 1/4" NPT connector.

NEED ASSISTANCE?

Call us on our toll- free customer support line:
1-866-349-8665 (Monday through Friday 9am – 5pm Eastern Standard Time)

- Technical questions
- Replacement parts
- Parts missing from package



Note these instructions pertain to the tool only. Please refer to your compressors operators manual and follow the manufacturers instructions.

TABLE OF CONTENTS

Product Specifications..... 1
Table of Contents..... 2
Safety Guidelines 3-6
Symbols 7
Tool Specific Warnings 8
Know Your Pneumatic Framing Nailer 9
Assembly And Operating 10-18
Maintenance 19
Troubleshooting 20-21
Exploded View 22
Parts List 23-25
Warranty..... 26

SAFETY GUIDELINES

WARNING:

This manual contains information that relates to PROTECTING PERSONAL SAFETY and PREVENTING EQUIPMENT PROBLEMS. It is very important to read this manual carefully and understand it thoroughly before using the product. The symbols listed below are used to indicate this information.

 **DANGER! Potential hazard that will result in serious injury or loss of life.**



 **WARNING! Potential hazard that could result in serious injury or loss of life.**



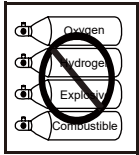

 **CAUTION! Potential hazard that may result in moderate injury or damage to equipment.**

Note - The word " Note " is used to inform the reader of something he / she needs to know about the tool.

PERSONAL SAFETY

These precautions are intended for the personal safety of the user and others working with the user. Please take time to read and understand them.

SYMBOL	MEANING
	<ul style="list-style-type: none"> • Do not use oxygen or any other combustible or bottled gas to power air-powered tools. Failure to observe this warning can cause explosion and serious personal injury or death. Use only the compressed air to power the air-powered tools. Use a minimum of 25' (7.6 m) of hose to connect the tool to the compressor. Failure to comply will result in serious injury or loss of life. 
	<ul style="list-style-type: none"> • Risk of electric shock: Do not expose a compressor to rain. Store it indoors. Disconnect the compressor from power source before servicing. Compressor must be grounded. Do not use grounding adaptors.
	<ul style="list-style-type: none"> • Risk of personal injury: Do not direct compressed air from the air hose towards the user or other personnel.

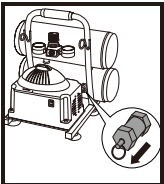
SYMBOL	MEANING
	<ul style="list-style-type: none"> • Risk of inhalation: Never directly inhale the air produced by the compressor.
	<ul style="list-style-type: none"> • Risk of bursting: Do not adjust the pressure switch or safety valve for any reason. They have been pre-set at the factory for this compressor's maximum pressure. Tampering with the pressure switch or the safety valve may cause personal injury or property damage.
	<ul style="list-style-type: none"> • Risk of burns. The pump and the manifold generate high temperatures. In order to avoid burns or other injuries, do not touch the pump, the manifold, or the transfer tube while the compressor is running. Allow the parts to cool down before handling or servicing. Keep children away from the compressor at all times.
	<ul style="list-style-type: none"> • Risk of bursting: Make sure the regulator is adjusted so that the compressor outlet pressure is set lower than the maximum operating pressure of the tool. Before starting the compressor, pull the ring on the safety valve to make sure the valve moves freely. Drain water from tank after each use. Do not weld or repair tank. Relieve all pressure in the hose before removing or attaching accessories. 



DANGER!

- Keep children away from the work area. Do not allow children to handle power tools.
- Do not use this tool in the presence of flammable liquids or gases. Sparks that are created during use may ignite gases.
- Keep air hose away from heat, oil, and sharp edges. Check air hose for wear before each use and ensure that all connections are proper.
- Always ensure that the workpiece is firmly secured leaving both hands free to control the tool.
- Always ensure that the tool has stopped before putting it down after use, for safety purposes and to prevent possible damage to the tool/user.
- Keep proper footing at all times in order to ensure correct balance.
- Always assume that the tool contains fasteners.
- Do not point the tool toward yourself or anyone else.



WARNING!

- Do not allow unskilled or untrained individuals to operate the air tool.
- Do not use the tool for any task other than that it is designed to perform.
- Locate the compressor in a well-ventilated area for cooling, and a minimum of 12" (31 cm) away from the nearest wall.
- Protect the air hose and the power cord from damage and puncture. Inspect them for weak or worn spots every week and replace them if necessary.
- Always wear hearing protection when using the air compressor. Failure to do so may result in hearing loss.
- Do not carry the compressor while it is running.
- Do not operate the compressor if it is not in a stable position.
- Do not operate the compressor on a rooftop or an elevated position that could allow the unit to fall or be tipped over.
- Always replace a damaged gauge before operating the unit again.
- Do not connect the tool to a compressed air source with a pressure output that is higher than 120psi.



CAUTION!

- Always ensure that the tool has stopped before disconnecting the air supply.
- Do not wear watches, rings, bracelets, or loose clothing when using any air- powered tool.
- Do not overload the tool. Allow the tool to operate at its optimum speed for maximum efficiency.
- Do not use a tool that is leaking air, that has missing or damaged parts, or that requires repairs. Verify that all screws are securely tightened.
- For optimal safety and tool performance, inspect the tool before every usage, in order to ensure free movement of the trigger, safety mechanisms, and springs.
- Always keep your air tool clean and lubricated. Daily lubrication is essential to avoid internal corrosion and possible failures.
- Ensure the floor is not slippery and wear non-slip shoes. Floors should be kept clean and clear.
- Always follow all workshop safety rules, regulations, and conditions when using the tool and keep the work area clean.
- Carry the tool by the handle only, keeping fingers away from the trigger. Do not carry the tool by the hose, magazine, or any other parts.
- Do not use the tool near or below freezing point, as doing so may cause tool failure.
- Do not store the tool in a freezing environment to prevent ice formation on the tools operating valves, as doing so may cause tool failure.
- Handling and storage of oil: Use with adequate ventilation. Avoid contact of oil with eyes, skin, and clothing. Avoid breathing spray or mist. Store in a tightly closed container in a cool, dry, well-ventilated area free from Incompatible substances.
- Tripping hazard. The air hose may become a tripping hazard when it is placed in the work area. Use care when walking in the work area.

**CAUTION!**

- Disconnect tool from the air supply and turn off the compressor before performing any maintenance or changing accessories, when clearing a jammed fastener, when the tool is not in use, when it is being handed to another person, and when it is left unattended. Failure to comply may result in moderate injury or damage to equipment.

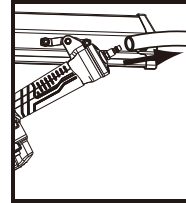

- Use safety goggles and ear protection: Wear safety glasses with side shields when operating the tool/compressor and verify that others in the work area are also wearing safety glasses. Safety glasses must conform to American National Standards Institute (ANSI Z87. 1) requirements and must provide protection from flying particles from the front and the sides.

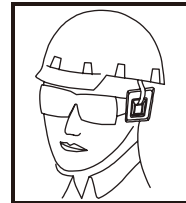













Air-powered tools are loud, and the sound can cause hearing damage.

Always wear ear protection to prevent hearing damage and loss. Failure to comply may result in moderate injury.

Note: Recycle unwanted materials rather than disposing of them as waste. Sort the tools, hoses, and packaging in specific categories and take to the local recycling centre or dispose of in an environmentally safe way.

SYMBOLS

⚠ WARNING: Some of the following symbols may appear on the tool. Study these symbols and learn their meaning. Proper interpretation of these symbols will allow for more efficient and safer operation of this tool.

V	Volts		Three-phase alternating current with neutral
A	Amperes		
Hz	Hertz		Direct current
W	Watts		No load speed
kW	Kilowatts		Alternating or direct current
μF	Microfarads		Class II construction
L	Litres		Splash-proof construction
kg	Kilograms		Watertight construction
H	Hours		Protective grounding at terminal, Class I tools
N/cm^2	Newtons per square centimetre	.../min	Revolutions or reciprocations per minute
Pa	Pascals		Diameter
Min	Minutes	0	Off position
S	Seconds		Directional arrow
~ or AC	Alternating current		Warning symbol
3 	Three-phase alternating current		Wear your safety glasses

TOOL SPECIFIC WARNINGS



DANGER Potential hazard that will result in serious injury or death.

- Do not disconnect or reconnect the air hose with the tool pressed or with a fastener in the guide. The tool may fire when it is reconnected to the air supply.



WARNING Potential hazard that could result in serious injury or death.

- Keep hands and other parts of the body away from the nail guide during use. Keep hands and feet and all other parts of the body at least 8" (20cm) away from the firing head.
- Objects in the workpiece can cause serious injury if they cause the fasteners to be deflected or to be driven away from the point of entry.
- Do not drive fasteners on top of a fastener. The fastener may ricochet, causing serious personal injury.
- Do not drive fasteners on scaffoldings, ladders, or such similar construction.
- Use only fasteners of the proper size and gauge, as specified in this manual.
- Do not drive fasteners close to the edge of the workpiece. The workpiece may split which could allow the fastener to fly free or ricochet and cause serious personal injury.

KNOW YOUR PNEUMATIC FRAMING NAILER

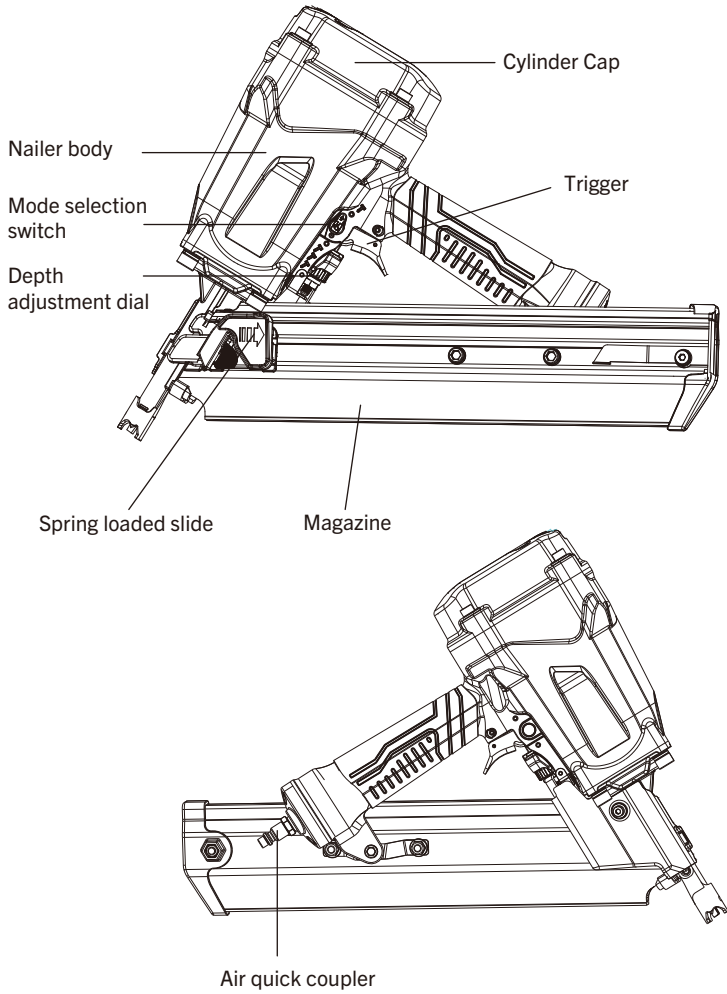

ASSEMBLY AND OPERATING

COMPATIBLE COMPRESSORS

GUIDELINES FOR PROPER USE AND OPERATION

Be sure to use a proper air compressor with air-powered tools. The compressor should be able to supply a minimal air delivery of 5.8 SCFM @ 90 psi to ensure the compressor can run continuously with the tool.

Air Compressor Size & Power	1 1/2 – 2 HP	2 1/2 HP	3 HP and more
4 - 6 Gallons	Light duty and intermittent use	Light duty and intermittent use	Light duty and intermittent use
8 - 11 Gallons	Light duty and intermittent use	Medium duty and intermittent use	Medium duty and intermittent use
15+ Gallons	Medium duty and intermittent use	Heavy duty and continuous use	Heavy duty and continuous use

Wood density	Nail size	Compressor air pressure
>0.6g/cm ³	<2.5" (63 mm)	100 psi
	≥2.5" (63 mm)	110 psi
≤0.6g/cm ³	<2.5" (63 mm)	70 psi
	≥2.5" (63 mm)	110 psi

Air system

Always use clean, dry, regulated, compressed air at 70-110 psi (4.8-7.5 bar). Do not exceed the maximum or minimum pressures. Operating the tool at the wrong pressure (too low or too high) will cause excessive noise or rapid wear of tool.

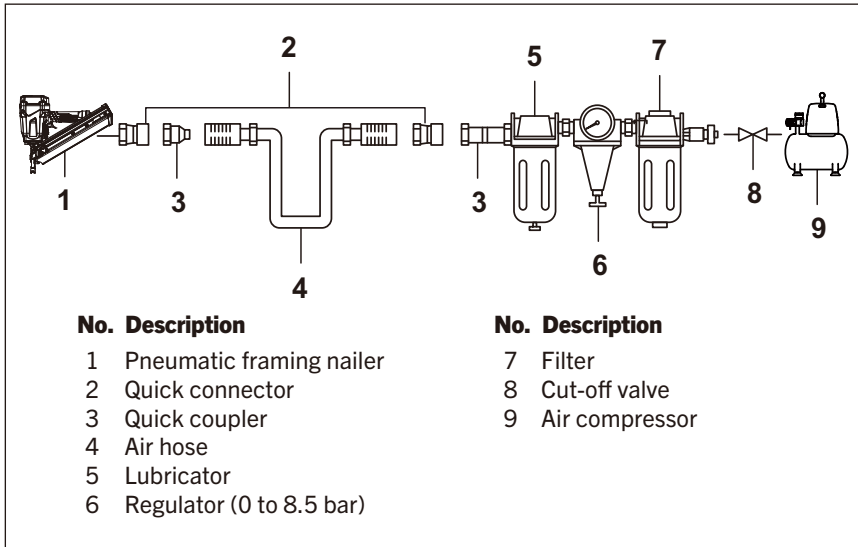

⚠️ WARNING! Potential hazard that could result in serious injury or loss of life.

- Always use clean, dry, regulated compressed air at 4.8 to 7.5 bar (70 to 110 PSI).
- Do not exceed the maximum and minimum pressures. Operating the tool at the wrong pressure will cause excessive noise, fast wear, or misfiring.
- It is recommended that a filter-regulator-lubricator be used and be located as close to the tool as possible.
- If a filter-regulator-lubricator is not installed, place up to 6 drops of compressor oil into the air inlet plug before each use.
- If a filter-regulator-lubricator is installed, keep the air filter clean. A dirty filter will reduce the air pressure to the tool, which will cause a reduction in power, efficiency, and general performance.
- For optimal performance, install a quick connector to the tool and a quick coupler on the hose, if applicable
- Verify that all the connections in the air supply system are sealed in order to prevent air from leaking.

Note: Please note that the filter-regulator-lubricator and air hose are sold separately. Read this Instruction Manual carefully before using the nailer.

ACCEPTABLE NAILS

This Pneumatic framing nailer drives 2 - 3 1/2" (50 to 90mm) long clipped-head framing nails.

Length: 2 - 3 1/2" (50 to 90 mm) (Fig A)

Angle: 34° (Fig B)

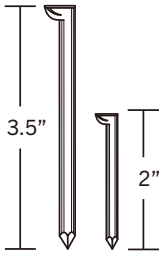

fig A

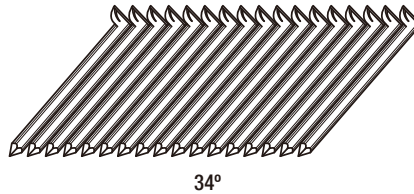

fig B



WARNING! Potential hazard that could result in serious injury or loss of life.

- The use of any other types of nails will cause the nailer to jam and could lead to serious injury.

This nailer can be used with a variety of shank types (e.g., ring, smooth, spiral) and a variety of coatings or nail compositions (e.g., Electro, mechanical, hot-dipped galvanized or stainless steel, etc.).

Nail type icons

These icons are used to select the proper nails for this specific nailer.



Note: Icons are color-coded, please refer the actual tool for the specific color

OPERATING INSTRUCTIONS

Features of the pneumatic framing nailer

- This lightweight pneumatic framing nailer drives 2 to 3 1/2" (50 to 90 mm) long pneumatic framing nails.
- It features
 - a hardened one-piece piston and an open magazine designed for easy extraction of jammed nails.
 - a rubber grip handle for improved control and added comfort, even during extended use.
 - a tool-free driving depth adjustment for driving nails flush or countersunk into various materials, which keeps projects moving.
 - a rear-loading magazine made of extruded aluminum for lighter weight and added durability.
- The hardened claw tip reduces wear and limits slippage when the tool is driven at an angle.
- Both sides of the main body protect both the operator and the workpiece.
- This framing nailer is ideal for construction framing, wall sheathing, roof sheathing, floor decking and similar applications.

Loading nails

⚠ DANGER! Potential hazard that will result in serious injury or loss of life.

- Disconnect the tool from the compressed air source before loading nails.
- Do not point the tool towards the operator or other people while changing or loading nails.
- Do not hold the tool with the trigger pressed while loading or changing the nails. Failure to comply will lead to serious injury or loss of life.

1. Disconnect the tool (1) from the air supply (2) (fig C).

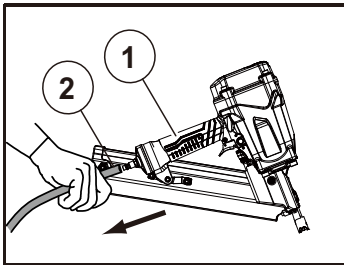

fig C

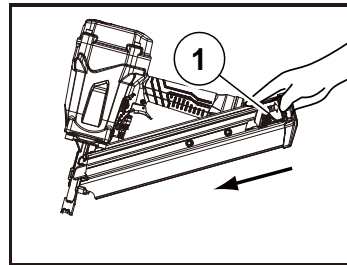

fig D

2. Take hold of the nailer firmly with one hand and use the other hand to press the spring-loaded slide (1) on the magazine and slide it back toward rear of tool (fig D).

3. Insert a strip of nails into the magazine. Ensure the points of the nails are facing down. Be sure to insert the heads of the nails into the channel. Release the spring-loaded slide until it meets the nails and locks in place to close the magazine (1) (Fig. E).

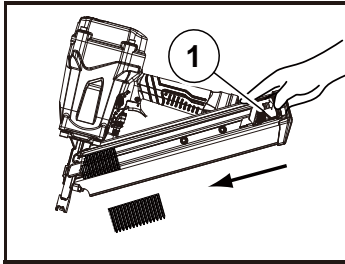

fig E

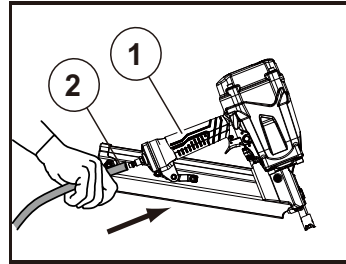

fig F

4. Plug in compressor, turn it on and set the pressure regulator to 90psi, attach one end of the air hose to the compressor and the other end of the air hose (1) to the tool (2). Use plumber's tape to avoid air leak (fig F).
5. Test the driving depth using a sample piece of wood before working on the workpiece. See wood density chart on page 9.



WARNING! Potential hazard that could result in serious injury or loss of life.

- Do not operate the tool if the nails are not loaded, doing so may damage the tool.
- Do not fire nails into the air, doing so may cause injury to the operators or others, apart from damaging the tool.
- Load the correct type of nails only and do not load different sized nails into the magazine, as doing so may cause nails to jam. Failure to comply could lead to serious injury or loss of life.



WARNING! Potential hazard that could result in serious injury or loss of life.

- Always know the operational mode of the nailer before using it. Failure to comply could lead to serious injury or loss of life.



WARNING! Potential hazard that could result in serious injury or loss of life.

- Hold the gun properly and mind the kick-back after each nail shot. Failure to comply will lead to serious injury or loss of life.

Adjusting nail depth

- For varying materials, the nail depth can be tool- free adjusted with the depth adjustment dial (Fig G)

Note: Refer to the graphic imprinted below the trigger and adjust the firing depth accordingly.

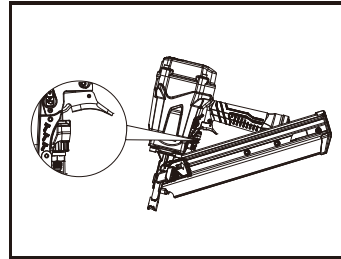

fig G

Increasing nail depth

Turn the depth adjustment dial (1) clockwise (with the discharge area of the tool facing away from the operator) (fig H).

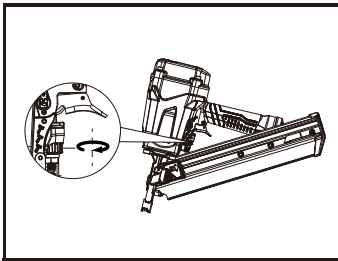

fig H

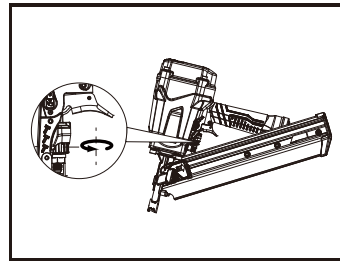

fig I

Decreasing nail depth

Turn the depth adjustment dial (1) counter- clockwise (with the discharge area of the tool facing away from the operator) (fig I).

Note: If after adjustment the nail is not going deep enough, adjust the pressure of the regulator on the compressor accordingly.

MODE SELECTION SWITCH

FIRING MODES

The Framing Nailer has two firing modes: **Single-Sequential actuation** for single firing, or **Contact / bump actuation** for repetitive, fast firing of nails. You may switch between these two modes simply by adjusting the Mode Selection Switch on the tool. For single sequential actuation mode, the selector switch must be positioned toward the back of the tool (toward the single nail icon on the tool. For repetitive firing, also know as contact or bump mode, the mode selector switch must be positioned toward the front of the tool (toward the multiple nail icon on the tool).

Ensure the switch is positioned either fully in single sequential or contact/bump mode, otherwise, if switch is in-between the tool will not function properly.

SINGLE SEQUENTIAL ACTUATION MODE

The single sequential actuation mechanism is for use where precise fastener placement is desired. The single sequential actuation mechanism may reduce the possibility of bodily injury to you or others in the work area compared to the contact/bump actuation mechanism. This is because it is less likely to drive an unwanted nail if you keep the trigger pulled and accidentally bump the push lever against yourself or others.

The single sequential actuation mechanism may also reduce the speed of operation compared to the contact/bump actuation mechanism. The single sequential actuation mechanism is recommended to inexperienced users.

1. Set switch on tool to single sequential actuation mode (fig. J).
2. Position the nose of the tool on the workpiece with your finger off the trigger.
3. Depress the push lever on the firing head of the tool firmly against the workpiece until it is completely depressed.
4. Pull the trigger to drive a nail.
5. Remove finger from the trigger.
6. To continue nailing in a separate location, move the nailer along the wood, repeating steps 2-5 as required

CONTACT OR BUMP MODE

* This mode is suitable when less precise nail placement is required. It allows the user to work more quickly.

1. Set switch on tool to contact or bump mode (fig. J).
2. Press and hold the trigger while operating in this mode. Each time the firing head contacts a workpiece, a nail is actuated (fired). Lift the nailer and locate it at the site for the next nail. Move the nailer along the workpiece with a bouncing motion. Each depression of the push lever on the firing head of the tool will drive a nail. As soon as the desired number of nails have been driven, remove finger from the trigger.
3. This process can be repeated until the trigger is released. Extreme care should be taken because a nail will be driven when the firing head contacts any surface.
4. Since nails can be actuated without removing the finger from the trigger, this is a less controlled mode, suitable for more experienced users.

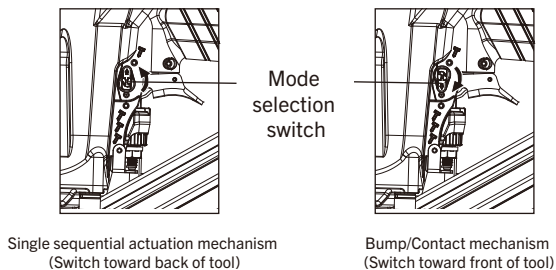

fig J

 **WARNING! Potential hazard that could result in serious injury or loss of life.**

To avoid double firing or accidental firing due to recoil

- 1) Do not press the nailer against the wood with excessive force.
- 2) Separate the nailer from the wood as it recoils after nailing.

 **WARNING! Potential hazard that could result in serious injury or loss of life.**

- Keep your finger of the trigger except during fastening operation because serious injury could result if the push lever on the nose of the tool accidentally contacts you or others in work area.
- Keep hands and body away from the discharge area. This nailer may bounce from the recoil driving a fastener and unwanted subsequent fastener may be driven, possibly causing injury.

NOTE:

- Always handle nails and package carefully. If nails are dropped, collating plastic may be broken.
- After nailing:
 - 1) Disconnect air hose from the nailer.
 - 2) Remove all nails from the nailer.
 - 3) Supply 5-10 drops of pneumatic tool lubricant into the air inlet plug on the nailer.
 - 4) Open the petcock on the air compressor tank to drain any moisture.

Filling the magazine

Only those fasteners specified under product specification may be used when filling the magazine, hold the tool so that the muzzle is not pointing towards the operator or any other person or animals.

Clearing a jammed nail

To clear a jammed nail

- Disconnect the tool from the air supply line.
Remove the nails that are stored in the tool's magazine.

 **WARNING! Potential hazard that could result in serious injury or loss of life.**

- Disconnect the air hose from the tool and remove the non-jammed nails from the tool before clearing a jammed nail.
- The nails are under pressure and failure to comply could cause them to be fired out of the tool causing serious injury.
- Use pliers or any appropriate tool to remove the jammed nails.
- Reload the nails into the tool magazine.
- Reconnect the air hose to the tool's air inlet.
- Test fire 3 to 5 nails into a piece of scrap wood in order to ensure a proper operation.

 **WARNING! Potential hazard that could result in serious injury or loss of life.**

- Do not point the tool towards the operator or other people. Serious personal injury could result if these instructions are not followed.

STORAGE

If it is necessary to store the tool for an extended period of time, apply a generous amount of lubrication before storing. The tool should be allowed to run for approximately 30 seconds after lubricating in order to ensure that the lubrication is uniformly distributed throughout the tool.

MAINTENANCE

Note: Do not store the tool anywhere temperatures will fall below freezing.



DANGER!

Disconnect the tool from the air compressor before maintenance/service, adjusting, cleaning jams, reloading, and when it is not in use. Repairs must be performed by a qualified service technician only. Failure to comply will lead to serious injury or loss of life.

MAINTENANCE REQUIRED	DESCRIPTION	TOOLS OR MATERIALS REQUIRED	MAXIMUM SERVICE INTERVAL		
			Each Use or every 2 Hrs.	Monthly	As Needed
General inspection – free movement	Trigger, spring, safety mechanism	None	X		
In-depth inspection	Worn or broken parts			X	X
Replace worn or broken parts					X
Lubrication	See below	Pneumatic tool oil	X		

Lubrication: If the tool and the compressor are not equipped with an in-line lubrication system, place up to 6 drops of pneumatic tool oil into the air inlet before each use or after every 2 hours of continuous use, depending on the characteristics of the workpiece and type of fasteners used.

Air-operated tools must be inspected periodically, and worn or broken parts must be replaced to ensure that the tools are operating safely and efficiently.

Inspect and replace worn or damaged O-rings, seals, etc. Tighten all screws and caps frequently in order to help prevent personal injury.

Keep the magazine of the tool clean and free of any dirt or abrasive particles.

TROUBLESHOOTING



DANGER! Potential hazard that will result in serious injury or loss of life.

If any of the following symptoms appear while the tool is in use, turn it off and disconnect it from the air supply immediately. Failure to comply will lead to serious injury or loss of life.

Disconnect the tool from the air supply before making any adjustments.

Repairs must be performed by a qualified service technician only.

The following chart lists common issues and solutions. Please read it carefully and follow all instructions carefully.

PROBLEM	POSSIBLE CAUSES	SOLUTIONS
Air leakage at the top of the tool or in the trigger area.	<ol style="list-style-type: none"> 1. O-rings in the trigger valve are damaged. 2. The trigger valve heads are damaged. 3. Trigger valve stem, seal, or O-rings are damaged. 	<ol style="list-style-type: none"> 1. Inspect and replace the O-rings. 2. Inspect and replace trigger valve heads. 3. Inspect and replace the trigger valve stem, seal, or O-rings. <p>Have the tool serviced by a qualified service technician.</p>
Air leakage at the bottom of the tool.	<ol style="list-style-type: none"> 1. The screws are loose. 2. The O-rings or the bumper are worn or damaged. 	<ol style="list-style-type: none"> 1. Tighten the screws. 2. Inspect and replace the O-rings or the bumper. <p>Have the tool serviced by a qualified service technician.</p>
Air leakage between the bottom and the cylinder cap.	<ol style="list-style-type: none"> 1. The screws are loose. 2. The O-rings or the seals are worn or damaged. 	<ol style="list-style-type: none"> 1. Tighten the screws. 2. Inspect and replace the O-rings or the seals. <p>Have the tool serviced by a qualified service technician.</p>
The nails are being driven too deep.	<ol style="list-style-type: none"> 1. The bumper is worn. 2. The air pressure is too high. 	<ol style="list-style-type: none"> 1. Replace the bumper. 2. Adjust the air pressure.
The tool does not operate properly-it does not drive the nails or operates sluggishly.	<ol style="list-style-type: none"> 1. The air supply is inadequate. 2. Lubrication is inadequate. 3. The O-rings or seals are worn or damaged. 4. The exhaust port in the cylinder head is blocked. 	<ol style="list-style-type: none"> 1. Verify that the air supply is adequate. 2. Pour up to 6 drops of oil into the air inlet. 3. Inspect and replace O-rings or seals. 4. Replace the damaged internal parts. <p>Have the tool serviced by a qualified service technician.</p>
The tool skips nails.	<ol style="list-style-type: none"> 1. The bumper is worn, or the spring is damaged. 2. There is dirt in the front plate. 3. Nails cannot move freely in the magazine because of dirt or damage. 4. The O-ring on the piston is worn or dry or there is not enough lubrication. 5. The cylinder cover seal is leaking. 	<ol style="list-style-type: none"> 1. Replace the bumper or pusher spring. 2. Open the drive channel on the front plate. 3. Open the magazine. 4. Replace the O-ring. 5. Replace the sealing washer. Have the tool serviced by a qualified service technician.

PROBLEM	POSSIBLE CAUSES	SOLUTIONS
The tool jams.	<ol style="list-style-type: none">1. Improper nails are used, or nails are damaged.2. The driver guide is damaged or worn.3. The magazine screw is loose.4. There is dirt in magazine.	see section "Clearing a jammed nail." <ol style="list-style-type: none">1. Use the proper nail.2. Inspect and replace the driver guide.3. Tighten the magazine.4. Open the magazine.
Air exhaust is being directed towards the operator.	The direction of the exhaust port requires adjustment.	Direct the exhaust port away from the operator.

EXPLODED VIEW

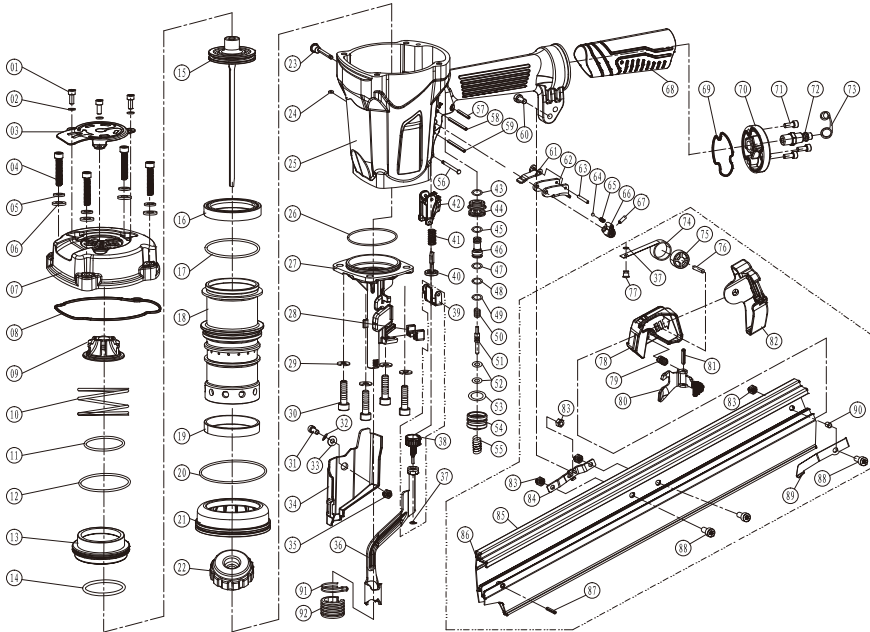

PARTS LIST

⚠ WARNING: When servicing, use only original equipment replacement parts. The use of any other parts may create a safety hazard or cause damage to the tool. Any attempt to repair or replace electrical parts on this tool may create a safety hazard unless repairs are performed by a qualified technician. For more information, call the Toll-free Helpline, at 1-866-349-8665.

Always order by part number.

Key #	Part #	Part Name	Quantity
1	03.04.05.030	Bolt M5x16	3
2	03.04.05.744	Washer 5	3
3	03.04.21.526	Exhaust cover	1
4	03.04.05.049	Bolt M5x35	4
5	03.04.05.265	Spring pin 6	4
6	03.04.05.747	Washer A level 6	4
7	03.04.28.135	Cylinder cover	1
8	03.04.19.258	Cylinder cover sealing washer	1
9	03.04.06.066	Cylinder cover bumper	1
10	03.04.36.130	Trigger valve spring	1
11	03.04.01.174	O-ring 48.7x2.65	1
12	03.04.01.201	O-ring 63x2.65	1
13	03.04.20.054	Trigger valve	1
14	03.04.01.014	O-ring 51.3x3.55	1
15	03.04.39.01.241	Piston	1
16	03.04.19.086	Cylinder sealing washer	1
17	03.04.01.198	O-ring 62.5x3.1	1
18	03.04.27.143	Cylinder	1
19	03.04.19.073	Sealing washer	1
20	03.04.01.213	O-ring 95x2.65	1
21	03.04.19.017	Collar	1
22	03.04.06.048	Bumper	1
23	03.04.15.173	Change level	1
24	03.04.01.027	O-ring 1.7x2	1
25	03.04.26.277	Gun body	1
26	03.04.01.196	O-ring 62x1.8	1
27	03.04.08.184	Nose	1
28	03.04.06.150	Nose rubber	2
29	03.04.05.267	Spring washer 8	4

Key #	Part #	Part Name	Quantity
30	03.04.05.056	Bolt M8x30	4
31	03.04.05.029	Bolt M5x14	1
32	03.04.05.263-03	Spring washer 5	1
33	03.04.05.256	Big washer 5	1
34	03.04.04.178	Nose protect cover	1
35	03.04.05.738-01	Nut M5	1
36	03.04.16.166	Safety shelf	1
37	03.04.05.237	Retaning ring 3	2
38	03.04.39.12.083	Adjuster assembly	1
39	03.04.17.165	Adjuster plate	1
40	03.04.15.086	Pushing lever	1
41	03.04.36.113	Pushing lever spring	1
42	03.04.32.085	Pushing lever guide	1
43	03.04.01.302	O-ring 14x1.8	1
44	03.04.32.175	Valve seat	1
45	03.04.01.082	O-ring 16x1.6	1
46	03.04.29.005	Valve bushing	1
47	03.04.01.047	O-ring 6.1x1.8	1
48	03.04.01.048	O-ring 6.4x2	1
49	03.04.01.060	O-ring 9x1.8	1
50	03.04.34.043	Trigger spring	1
51	03.04.15.043	Trigger pole B	1
52	03.04.01.032	O-ring 2.4x1.6	2
53	03.04.01.097	O-ring 20x1.8	1
54	03.04.32.150-01	Trigger seat	1
55	03.04.36.006	Compressed srping	1
56	03.04.31.171	Roll pin	1
57	03.04.05.349	Pin 3x28	1
58	03.04.05.197	Pin 3x30	1
59	03.04.05.194	Pin 3x22	1
60	03.04.05.046	Bolt M6x22	1
61	03.04.02.105	Trigger arm	1
62	03.04.03.031-01	Trigger	1
63	03.04.05.186	Pin 2.5x16	1
64	03.04.40.130	Steel ball Dw=4	1
65	03.04.36.097	Spring	1
66	03.04.40.047	Change knob	1

Key #	Part #	Part Name	Quantity
67	03.04.05.189	Pin 3x10	1
68	03.04.29.265	Gun body grip	1
69	03.04.19.038	End cover sealing washer	1
70	03.04.11.027-05	End cover	1
71	03.04.05.032	Bolt M5x20	3
72	03.04.40.170	Air inlet plug	1
73	03.04.29.158	Air inlet plug case	1
74	03.04.34.036-02	Spring A	1
75	03.04.22.021	Spring core	1
76	03.04.05.220	Pin 4x18	1
77	03.04.34.043	Spring pin	1
78	03.04.32.174	Nail feeder seat	1
79	03.04.36.092	Nail guide spring	1
80	03.04.09.183	Nail guide	1
81	03.04.05.225	Pin 4x30	1
82	03.04.04.178	Magazine cover	1
83	03.04.05.739-01	Nut M6	4
84	03.04.12.194	Fixed seat	1
85	03.04.18.101	Magazine	1
86	03.04.30.127	Nail rail	1
87	03.04.05.228	Pin 3x8	1
88	03.04.05.040	Bolt M6x12	3
89	03.04.25.153	Nail stopper	1
90	03.04.29.235	Bushing	1
91	05.04.28.003	Steel wire collar	1
92	05.04.26.036	Nose	1

WARRANTY

BENCHMARK WARRANTY

If this Benchmark tool fails due to a defect in material or workmanship within five years from the date of purchase, return it to any Home Hardware store with the original bill of sale for exchange. 3-year warranty for the battery and charger. This warranty does not include expendable parts including but not limited to blades, brushes, belts, light bulbs. This warranty covers defects in material or workmanship only. It does not cover normal wear and tear, failure due to abuse/misuse, or defects caused by careless or accidental mishandling. If this Benchmark product is used for commercial or rental purposes, this warranty does not apply.

PNEUMATIC FRAMING NAILER



*5 year limited warranty on tool

BENCHMARKTM_{MC}

BENCHMARK TOOLS CANADA

ST. JACOBS, ONTARIO N0B 2N0

© 2021 Home Hardware Stores Limited

CUSTOMER SERVICE/TECH SUPPORT

1-866-349-8665

1282 151

Made in China



*This BenchmarkTM product carries a five (5) year LIMITED warranty against defects in workmanship and materials. The charger and batteries carry a three (3) year LIMITED warranty. See Owner's Manual for full details.

**READ ALL INSTRUCTIONS BEFORE FIRST USE.
KEEP THIS MANUAL FOR FUTURE REFERENCE.
KEEP AWAY FROM CHILDREN.**



**WEAR CSA APPROVED
EYE PROTECTION**



**WEAR EAR
PROTECTION**



**WEAR A
FACE MASK**