

Radley®

8V CORDLESS MINI ROTARY TOOL KIT

OWNER'S MANUAL

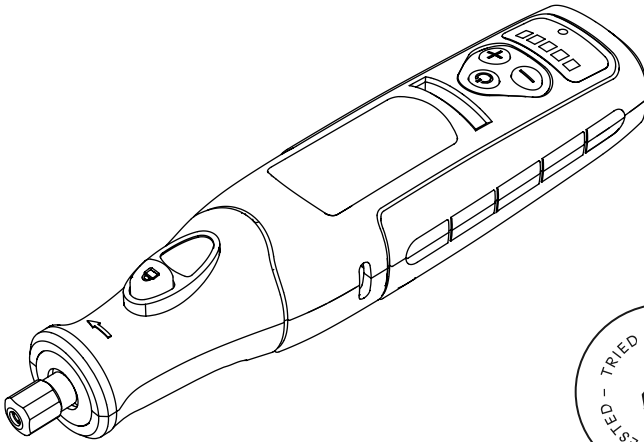

1 Year Limited Warranty on tool



800626

**READ ALL INSTRUCTIONS BEFORE FIRST USE.
KEEP THIS MANUAL FOR FUTURE REFERENCE.
KEEP AWAY FROM CHILDREN.**



**WEAR CSA APPROVED
EYE PROTECTION**



**WEAR EAR
PROTECTION**



**WEAR FACE
PROTECTION**

WHAT'S IN THE BOX

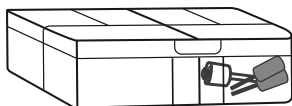

24 Accessories



Charger



Please carefully read this user manual before operating the rotary tool.

TABLE OF CONTENTS

Electrical Safety Warnings	2
General Power Tool Safety Warnings	2-4
Rotary Tool Safety Warnings	4-7
Battery and Charger Safety Warnings	7-8
Description of Symbols	8
Know your Product	9
Charging the Tool	9
Unpacking and Set-Up	10-11
Controls	11
Operation	12
Accessories	12-14
Maintenance	15
Troubleshooting	15
Warranty	16

ELECTRICAL SAFETY WARNINGS

⚠ WARNING! When using power tools, basic safety precautions should always be followed to reduce the risk of fire, electric shock, personal injury and material damage. Before operating the unit, carefully read the entire manual and be certain you know how to switch the unit off in case of an emergency. Be sure to save these instructions and any other documents supplied with this unit for future reference.

Note: The power outlet used for the power tool/charger must be protected by a 30mA ground fault circuit interrupter or earth leakage circuit breaker. If the supply cord is damaged, it must be replaced by an electrician or a power tool repairer in order to avoid a hazard.

GENERAL POWER TOOL SAFETY WARNINGS

⚠ WARNING! Read all safety warnings and all instructions. Failure to follow the warnings and instructions may result in electric shock, fire and/or serious injury.

Save all warnings and instructions for future reference. The term "power tool" in the warnings refers to your mains operated (corded) power tool or battery operated (cordless) power tool.

WORK AREA SAFETY

- **Keep work area clean and well lit.** Cluttered or dark areas invite accidents.
- **Do not operate power tools in explosive atmospheres, such as in the presence of flammable liquids, gases or dust.** Power tools create sparks which may ignite the dust or fumes.
- **Keep children and bystanders away while operating a power tool.** Getting distracted while using the tool may lead to injury for the operator or bystanders if not exercising proper safety.

ELECTRICAL SAFETY

- **Power tool plugs must match the outlet. Never modify the plug in any way. Do not use any adapter plugs with earthed (grounded) power tools.** Unmodified plugs and matching outlets will reduce risk of electric shock.
- **Avoid body contact with earthed or grounded surfaces, such as pipes, radiators, ranges and refrigerators.** There is an increased risk of electric shock if your body is earthed or grounded.
- **Do not expose power tools to rain or wet conditions.** Water entering a power tool will increase the risk of electric shock.
- **Do not abuse the cord. Never use the cord for carrying, pulling or unplugging the power tool. Keep cord away from heat, oil, sharp edges or moving parts.** Damaged or entangled cords increase the risk of electric shock.
- **When operating a power tool outdoors, use an extension cord suitable for outdoor use.** Use of a cord suitable for outdoor use reduces the risk of electric shock.
- **If operating a power tool in a damp location is unavoidable, use a ground fault circuit interrupter (GFCI) protected supply with a rated leakage current of 30 mA or less.** Use of a GFCI reduces the risk of electric shock.

PERSONAL SAFETY

- **Always be sure to pay close attention to what you are doing when operating a power tool.** Do not use a power tool when you are tired or under the influence of drugs, alcohol or medication. A moment of inattention while operating power tools may result in serious personal injury.
- **Use personal protective equipment. Always wear eye protection.** Under the appropriate condition, protective equipment such as a dust mask, non-skid safety shoes, hard hat, or hearing protection can reduce personal injuries.
- **Prevent unintentional starting. Make sure the switch is in the off-position before picking up or carrying the tool or connecting the unit to a power source/battery pack.** Carrying power tools with your finger on the switch or energizing power tools that have the switch on may lead to accidents.
- **Remove any adjusting key or wrench before turning the power tool on.** A wrench or a key left attached to a rotating part of the power tool may result in personal injury.
- **Do not overreach. Keep proper footing and balance at all times.** This enables better control of the power tool in unexpected situations.
- **Dress properly. Do not wear loose clothing or jewelry. Keep your hair, clothing and gloves away from moving parts.** Loose clothes, jewelry or long hair, can get caught in moving parts resulting in serious injury.
- **If devices are provided for the connection of dust extraction and collection facilities, ensure these are connected and properly used.**

POWER TOOL USE AND CARE

- **Do not force the power tool. Use the correct power tool for your application.** The correct power tool will do a better and safer job when used for its designed purpose.
- **Do not use the power tool if the on/off switch is malfunctioning.** Any power tool that cannot be controlled with the switch is dangerous and must be repaired.
- **Disconnect the plug from the power source and/or the battery pack from the power tool before making any adjustments, changing accessories, or storing power tools.** This helps reduce the risk of starting the power tool accidentally.
- **Store idle power tools out of the reach of children .** Do not allow persons unfamiliar with the power tool to operate it without first reading these instructions. Power tools are dangerous in the hands of untrained users.
- **Properly maintain power tools. Check for misalignment or binding of moving parts, breakage of parts and any other condition that may affect the power tool's operation. If damaged, have the power tool repaired before use.** Many accidents are caused by poorly maintained power tools.
- **Keep cutting tools sharp and clean.** Properly maintained cutting tools with sharp cutting edges are less likely to bind and are easier to control.
- **Use the power tool, accessories, and tool bits, etc. by following these instructions, taking into account the working conditions and the work to be performed.** Use of the power tool for operations different from those intended could create a hazardous situation.

SERVICE

- **Have your power tool serviced by a qualified repair person using only identical replacement parts.** This will ensure that the power tool is properly and safely maintained.

- **If the supply cord is damaged, it must be replaced by the manufacturer, its service agent or similarly qualified persons to prevent any potential hazard.**

ROTARY TOOL SAFETY WARNINGS

This appliance should only be used by able-bodied individuals. Younger persons should only use the tool when supervised by a responsible person who can ensure the tool is being used safely. Young children should not be allowed to use the tool - it is not a toy!

⚠️ WARNING! Safety warnings are common for grinding, sanding, wire brushing, polishing or abrasive cutting-off operations.

- This power tool is intended to function as a grinder, sander, wire brush, polisher or cut-off tool. Read all safety warnings, instructions, illustrations and specifications provided with this power tool. Failure to follow all instructions listed below may result in electric shock, fire and/or serious injury.
- Operations for which the power to it was not designed to create a hazard and cost personal injury.
- Do not use accessories which are not specifically designed and recommended by the tool manufacturer. Just because the accessory can be attached to your power tool, it does not ensure safe operation.
- The rated speed of the accessory must be at least equal to the maximum speed mark on the power tool. Accessories running faster than the rate of speed can break and fly apart.
- The outside diameter and the thickness of your accessory must be within the capacity rating of your power tool. Incorrectly sized accessories cannot be adequately guarded or controlled.
- Threaded mounting of accessories must match the grinder spindle thread. For accessories mounted by flanges, the arbour hole of the accessory must fit the locating diameter of the flange. Accessories that do not match the mounting hardware of the power tool will run out of balance, vibrate excessively and may cause loss of control.
- Do not use a damaged accessory. Before each use, inspect the accessory for potential damage (i.e., abrasive wheels for chips and cracks, backing pad for cracks/tears or excess wear, wire brush for loose or cracked wires.) If power tool or accessory is dropped, inspect for damage or install an undamaged accessory. After inspecting and installing an accessory, position yourself and any standers away from the plane of the rotating accessory and run the power tool at maximum no load speed for one minute. Use caution as damaged accessories will normally break apart during this testing.
- Wear personal protective equipment. Depending on application, use face shield, safety goggles or safety glasses. As appropriate, wear dust mask, hearing protectors, gloves and workshop apron capable of stopping small abrasive or workpiece fragments. The eye protection must be capable of stopping flying debris generated by various operations. The dust mask or respirator must be capable of filtering particles generated by your operation. Prolonged exposure to high intensity noise may cause hearing loss.
- Keep bystanders a safe distance away from work area. Anyone entering the work area must wear personal protective equipment. Fragments of workpiece or of a broken accessory may become airborne and cause injury beyond immediate area of operation.

- Hold the power tool by insulating gripping surfaces only, especially when performing an operation with a cutting accessory may contact hidden wiring or its own cord. If the cutting accessory comes into contact with a live wire, it may cause exposed metal parts of the power tool to become live too, resulting in electric shock to the operator.
- Position the cord clear of the spinning accessory. If you lose control of the tool, the cord may be cut or snagged, and your body pulled into the spinning accessory resulting in potential injury.
- Never lay the power tool down until the accessory has come to a complete stop or the spinning accessory may grab the service and the power tool out from your control.
- Do not run the power to while carrying it at your side. Accidental contact with the spinning accessory could snag your clothing, pulling the accessory into your body.
- Regularly clean the power tools air vents. The motors fan will dry the dust inside the housing an excessive accumulation of powdered metal may cause electrical hazards.
- Do not operate the power tool near flammable materials as sparks could ignite these materials.
- Do not use accessories that require liquid coolants. Using water or other liquid coolants may result in shock or electrocution.

KICKBACK AND RELATED WARNINGS

Kickback is a sudden reaction to a pinched or snag rotating wheel, backing pad, brush or any other accessory. Pinching or snagging causes rapid stalling of the rotating accessory which, in turn, causes the uncontrolled power tool to be forced in the direction opposite of the accessory's rotation at the point of the binding.

For example, if an abrasive wheels snag or pinched by the work piece, the edge of the wheel that is entering into the pinch point can dig into the surface of the material causing the wheel to climb out or kick out.

1. Kickback is the result of power tool misuse and/or incorrect operating procedures or conditions and can be avoided by taking proper precautions as outlined below.

1.1 Maintain a firm grip on the power tool and position your body and arm to allow you to resist kickback forces. Always use auxiliary handle, if provided, for maximum control over kickback or torque reaction during start-up. The operator can control torque reactions or kickback forces, if proper precautions are taken.

1.2 Never place your hand near the rotating accessory since the accessory may kickback over your hand.

1.3 Do not position your body in the area where power tool will move if kickback occurs. Kickback will propel the tool in the opposite direction to the wheel's movement at the point of snagging.

1.4 Use special care when working corners, sharp edges, etc. Avoid bouncing and snagging the accessory. Corners, sharp edges or bouncing have a tendency to snag the rotating accessory and may result in loss of control or kickback.

1.5 Do not attach a saw chain woodcarving blade or toothed saw blade to the tool as such blades create frequent kickback and loss of control.

2. Safety warnings specific for grinding and abrasive cutting-off operations:

2.1 Use only wheel types that are recommended for your power tool and the specific guard designed for the selected wheel. Wheels for which the power tool was not

designed for cannot be adequately guarded and are unsafe.

2.2 The grinding surface of center depressed wheels must be mounted below the plane of the guard lip. An improperly mounted wheel that projects through the plane of the guard lip cannot be adequately protected.

2.3 Wheels must be used only for recommended applications. (For example, do not grind with the side of cut-off wheel. Abrasive cut-off wheels are intended for peripheral grinding, side forces applied to these wheels may cause them to shatter.)

2.4 Always use undamaged wheel flanges that are of correct size and shape for your selected wheel. Proper wheel flanges support the wheel thus reducing the possibility of wheel breakage. Flanges for cut-off wheels may be different from grinding wheel flanges.

2.5 Do not use worn down wheels from larger power tools. A wheel intended for larger power tool is not suitable for the higher speed of a smaller tool and may burst.

3. Additional safety warnings specific for abrasive cutting-off operations:

3.1 Do not “jam” the cut-off wheel or apply excessive pressure. Do not attempt to make an excessive depth of cut. Over stressing the wheel increases the loading and susceptibility to twisting or binding of the wheel in the cut and the possibility of kickback or wheel breakage.

3.2 Do not position your body in line with and behind the rotating wheel. When the wheel, at the point of operation, is moving away from your body, the possible kickback may propel the spinning wheel and the power tool directly at you.

3.3 When wheel is binding or when interrupting a cut for any reason, switch off the power tool and hold the power tool motionless until the wheel comes to a complete stop. Never attempt to remove the cut-off wheel from the cut while the wheel is in motion, otherwise kickback may occur. Investigate and take corrective action to eliminate the cause of wheel binding.

3.4 Do not restart the cutting operation in the workpiece. Let the wheel reach full speed and carefully re-enter the cut. The wheel may bind, walk up or kickback if the power tool is restarted in the workpiece.

3.5 Support panels or any oversized workpiece to minimize the risk of wheel pinching and kickback. Large workpieces tend to sag under their own weight. Supports must be placed under the workpiece near the line of cut and near the edge of the workpiece on both sides of the wheel.

3.6 Use extra caution when making a “pocket cut” into existing walls or other blind areas. The protruding wheel may cut gas or water pipes, electrical wiring or objects that can cause kickback.

4. Safety warnings specific for sanding operations:

4.1 Do not use excessively oversized sanding disc paper. Follow the manufacturer's recommendations when selecting sanding paper. Larger sanding paper extending beyond the sanding pad presents a laceration hazard and may cause snagging, tearing of the disc or kickback.

5. Safety warnings specific for polishing operations:

5.1 Do not allow any loose portion of the polishing bonnet or its attachment strings to spin freely. Tuck away or trim any loose attachment strings. Loose and spinning

attachment strings can entangle your fingers or snag on the workpiece.

6. Safety warnings specific for wire brushing operations:

6.1 Be aware that wire bristles are thrown by the brush even during ordinary operation. Do not overstress the wires by applying excessive load to the brush. Exercise caution as, the wire bristles can easily penetrate light clothing and/or skin.

6.2 If the use of a guard is recommended for wire brushing, do not allow any interference of the wire wheel or brush with the guard. Wire wheel or brush may expand in diameter due to work load and centrifugal forces.

6.3 Direct the discharge of the spinning wire brush away from you. Wear safety gloves and proper clothing as small particles and tiny wire fragments may discharge at high velocity when using these brushes and can penetrate your skin.

BATTERY AND CHARGER SAFETY WARNINGS





 **WARNING!** This manual contains important safety and operating instructions for your battery and charger.

Before using the charger, read all instructions and cautionary markings on the charger, battery and the product using the battery.

- This charger is not intended for any uses other than charging rechargeable batteries. Any other use may result in risk of fire, electric shock or electrocution.
- Since battery tools do not have to be plugged into an electric outlet, they are always in an operational condition. Be aware of possible hazards when not using the battery tool or when changing accessories. Following this rule will reduce the risk of electric shock, fire and serious personal injury.
- Do not place battery tools or batteries near fire or heat. This will reduce the risk of explosion and possibly injury.
- Do not crash, drop or damage battery. Do not use a battery or charger that has been dropped or has received a sharp blow. A damaged battery is subject to explosion. Properly dispose of a dropped or damaged battery immediately.
- To avoid damage to the electric plug and cord when disconnecting the charger, be sure to pull by the plug-in not the cord. Make sure the cord is placed where it will not be stepped on, tripped over, or otherwise subjected to damage or stress.
- To reduce risk of electric shock, unplug the charger from the outlet before attempting any cleaning. Removing the battery will not reduce this risk.
- A battery can explode or catch near a source of ignition, such as a pilot light. To reduce the risk of serious personal injury, never use any cordless product near an open flame. If a battery exploded, you can propel debris and hazardous chemicals. If exposed and debris or chemicals, use water immediately to flush away particles/residue.
- Do not charge battery in a damp or wet location. Do not use, store or charge battery or products in locations where the temperature is less than 50°F or more than 100°F.
- Under extreme usage or temperature conditions, battery leakage may occur. If liquid comes in contact with your skin, wash immediately with soap and water. If liquid gets into your eyes. Flush them with clean water for at least 10 minutes, then seek immediate medical attention. Following this rule will reduce the risk of serious personal injury.

- Never attempt to open the battery or charger for any reason. If the plastic housing on the battery pack or charger breaks or cracks, immediately discontinue use and do not recharge.
- The battery is not fully charged out of the carton. First read the safety instructions and then follow the charging notes and procedures.
- Save these instructions. Refer to them frequently and use them to educate others who may use this tool. If you long is too old to someone, are you sure they are familiar with these instructions too.

DESCRIPTION OF SYMBOLS

V	Volts	Hz	Hertz
~ or AC	Alternating current	W	Watts
— — —	Direct current	Ah	Amp hour
mA	Milliamperes	N·m	Newton Meters
n_0	No load speed	/min	Revolutions or reciprocation per minute
	Warning		Read instruction manual
	Thermal cut-out protection		Indoor use only
			Polarity

KNOW YOUR PRODUCT

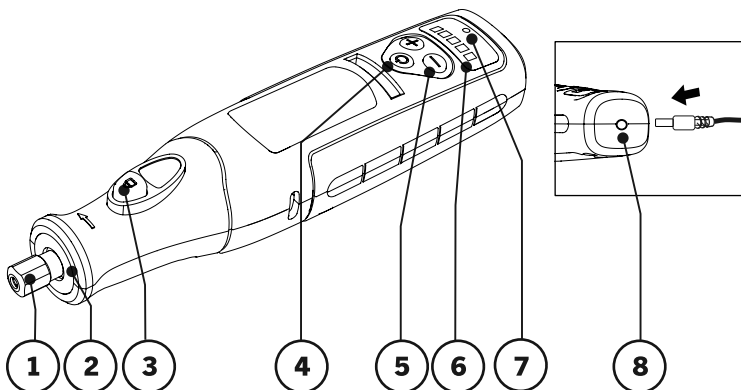

- | | |
|------------------------|-------------------------------|
| 1. Collet Nut | 5. Speed Control Button |
| 2. LED Worklight | 6. LED Speed Indicator Lights |
| 3. Spindle Lock Button | 7. Battery Charging Light |
| 4. On/Off Button | 8. Charging Port |

SPECIFICATIONS

Voltage Rating: 8V DC	Charger Output: 9V 0.5A
Rated Speed: 5,000-25000/min	Charging Time: 2-3 hours
Collect Size: 1/8" (3.2 mm)	Max running time at no load: 3 hours
Battery: 900mAh Li-ion, Built-in	Weight: 0.7 lbs

CHARGING THE TOOL

Insert USB charging cable output end into the USB charging port on the rotary tool, then plug power adapter into the 120VAC standard power outlet.

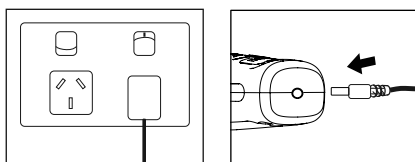

CHARGING LED INDICATORS

Charging - Red LED Light

Fully Charged - Green LED light

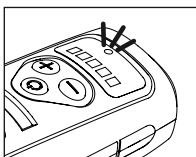

UNPACKING AND SET-UP

CHANGING ACCESSORIES

1. Press and hold the spindle lock button.
2. Unscrew the collet nut and remove completely with the supplied wrench.
3. Select a suitable collet for the accessory to be used and insert, then cover with collet nut.

(**Note:** The shipped machine is already fitted with a collet of 1/8")

4. Lightly tighten the collet nut so that it stays in place.
5. Insert shank of accessory into the collet.
6. Tighten collet nut using spindle lock and wrench.

CAUTION: It is recommended that no accessory larger than 35mm (1.37") in diameter should be fitted to the rotary tool.

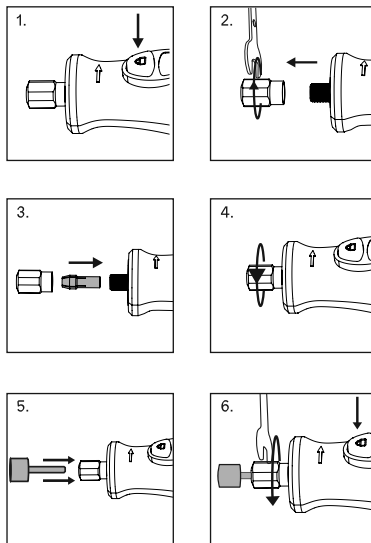

LOCATING A CUTTING/SANDING DISC

1. Remove the screw from the end of the mandrel with the wrench.
2. Fit the fibre flange on either side of the cutting/sanding disc, then insert the screw.
3. Tighten the cutting/sanding disc onto the cutting/sanding mandrel with the wrench.

NOTE: DO NOT over tighten the screw as it could result in damage to the cutting disc.

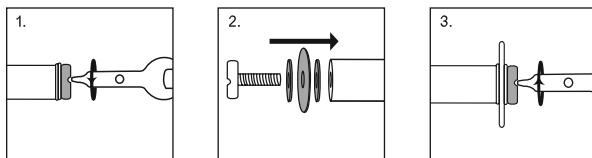

LOCATING A SANDING BAND

1. Loosen the screw on the top of the sanding drum with the wrench.
2. Slide the sanding band onto the sanding drum.
3. Tighten the screw with the wrench until the sanding band is secured.

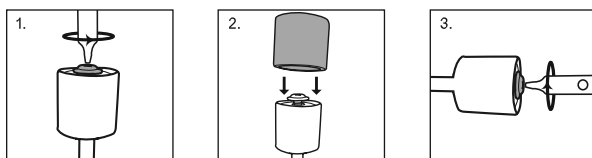

LOCATING A FELT WHEEL

1. Screw mandrel end to align with the center of felt wheel.
2. Apply slight pressure and screw into place in clockwise direction.

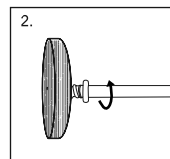
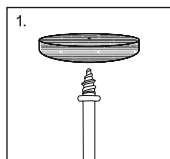

CONTROLS

TURN ON OR OFF ROTARY TOOL

1. To turn the tool "ON"

Press and release the on/off button. The tool will start working at a speed of 5,000 rpm and the LED worklight will turn on. If the on/off button is pressed but not released the tool and LED worklight won't turn on.

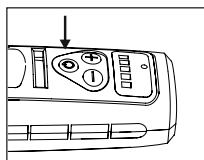

2. To turn the tool "OFF"

Press and release the on/off button. If for some reasons the on/off button doesn't work there is always the option to alternatively turn off the tool by the following methods: Press the minus (-) speed control button to bring the speed of the tool to the lowest speed level (5,000 RPM). Hold the minus (-) speed control button for 5 seconds.

SPEED ADJUSTMENT

The speed of the tool can be regulated to suit a variety of applications and materials. Press the speed control button to select the desired speed. Press plus (+) for increasing speed. Press minus (-) for reducing speed.

Low speed use:

This speed would be used for fragile model parts. It is recommended that the various shape grinding stones be used at low speed to prevent them from becoming too hot and deteriorating.

High speed use:

Glass projects require high speed drilling.

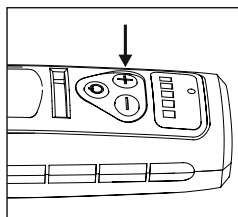

OPERATION

OPERATING THE ROTARY TOOL

⚠ WARNING! Be sure workplace is securely clamped down and then turn the rotary tool on.

1. Select the appropriate speed for the application.
2. For high precision applications, such as engraving or milling, hold the rotary tool like a pen.
3. For heavy work like cutting or grinding, hold the rotary tool in the palm of your hand.
4. Gently apply the tip of the accessory to the work piece.

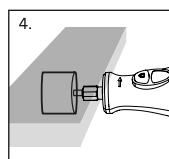
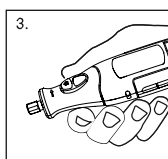
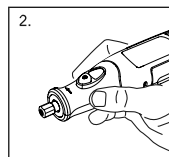
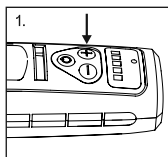

CAUTION: Placing excessive load on the rotary tool while it is running at low speed may cause it to overheat and the motor to fail.

ACCESSORIES

Note: Each number setting listed in the speed charts = x 1,000 RPMS.

- Speed for light cuts, Caution - burning on deep grooves.
- Depending on cutting direction relative to grain

STONE GRINDING BITS								
	Soft Wood	Hard Wood	Laminates / Plastics	Steel	Aluminum, Brass, etc.	Shell/ Stone	Ceramic	Glass
	25	25	-	18-24	9-11	12-17	25	-
Applications	Suitable for various kinds of grinding and sharpening applications. Available in a wide range of sizes and shapes - round pointed, flat etc.							

DIAMOND BITS								
	Soft Wood	Hard Wood	Laminates/ Plastics	Steel	Aluminum, Brass, etc.	Shell/ Stone	Ceramic	Glass
	25	18-24	-	-	-	25	25	25
Applications	Made for intricate work on ceramics. wood carvings, jewelry and scrimshaw. Available in a wide variety of shapes and sizes.							

SANDING BANDS AND PAPER IF EQUIPPED								
	Soft Wood	Hard Wood	Laminates/ Plastics	Steel	Aluminum, Brass, etc.	Shell/ Stone	Ceramic	Glass
	5- 25	5- 25	5- 17	25	25	5- 25	5- 25	-
Applications	Shapes wood, smooths fiberglass, sands inside curves and other difficult to reach areas.							

WOOL POLISHING WHEELS								
	Soft Wood	Hard Wood	Laminates/ Plastics	Steel	Aluminum, Brass, etc.	Shell/ Stone	Ceramic	Glass
	-	-	-	12-17	12-17	12-17	12-17	12-17
Applications	Used for bringing metal surfaces to a smooth finish. Use with polishing compound to bring a high shine to the finish.							

BRISTLE BRUSH								
	Soft Wood	Hard Wood	Laminates/ Plastics	Steel	Aluminum, Brass, etc.	Shell/ Stone	Ceramic	Glass
	9-11	9-11	5-11	9-11	9-11	9-11	-	-
Applications	Ideal cleaning tools on silverware, jewelry and antiques.							

MULTIPURPOSE CUTTER								
	Soft Wood	Hard Wood	Laminates/ Plastics	Steel	Aluminum, Brass, etc.	Shell/ Stone	Ceramic	Glass
	25	18-24	9-11	25	12-17	18-24	18	18
Applications	Ideal for shaping, smoothing or removing material from especially hard materials.							

HSS DRILL BIT								
	Soft Wood	Hard Wood	Laminates/Plastics	Steel	Aluminum, Brass, etc.	Shell/Stone	Ceramic	Glass
	25	25	5-11	-	12-17	-	-	-
Applications	Used to cuts wood, plastic, fiberglass, drywall, laminate and aluminum and vinyl siding.							

CUT-OFF WHEEL								
	Soft Wood	Hard Wood	Laminates/Plastics	Steel	Aluminum, Brass, etc.	Shell/Stone	Ceramic	Glass
	-	-	5-11	25	25	25	25	-
Applications	Ideal for shaping, smoothing or removing material from especially hard materials.							

COLLET	
	Used to fit a variety of accessories with different shank sizes to your rotary tool.

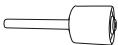
SANDING DRUM	
	A shank used with sanding bands.

SCREW MANDREL	
	A shank which screws into the wool polishing tip and wheels.

MANDREL	
	This is a mandrel with a small screw at its tip and is used with cut-off wheels, sanding discs, cutting discs etc.

WRENCH	
	Used to fasten accessories to the mandrels.

MAINTENANCE

CLEANING AND STORING

Keep the vents of the rotary tool clean at all times. If possible, prevent foreign matter from entering the vents.

After each use, blow air through the rotary tool housing to ensure it is free from all dust particles which may build up. Build up of dust particles may cause the rotary tool to overheat and fail.

If the enclosure of the rotary tool requires cleaning, do not use solvents but a moist soft cloth only. Never let any liquid get inside the rotary tool.

Never immerse any part of the rotary tool into a liquid.

If the supply cord is damaged, it must be replaced by the manufacturer, its service agent or similarly qualified persons to prevent any potential hazard.

Always store the rotary tool indoors.

ACCESSORIES

All accessories can be kept in the plastic accessory container for convenient storage or transport.

TROUBLESHOOTING

Trouble	Possible Cause	Remedy
Tool will not turn on	ON/OFF button does not work	Check that the button is properly engaging the electronic assembly
	Battery no power	To charge the battery with the supplied charger then turn the tool after the battery is fully charged
	Faulty electronic assembly	Replace the entire electronic assembly
Can not adjust the speed	Speed control button loose or faulty electronic assembly	Replace the entire electronic assembly
Shaft on the rotary tool will not lock	Faulty shaft lock button	If the shaft rotates even when the shaft lock is pressed, the button will need be replaced
Tool is overheating	Ventilation slots are covered	Clean the vents, ensure that they are not covered by dust, dirt etc.
	Overuse or over pressure onto rotary tool	During use, make sure to pause occasionally to reduce temperature (especially working at low speed condition). Apply proper pressure when using tool according to its rating
Bits or collet no longer tighten/loosen	Collet flexibility Collet nut worn out Bits shank worn out	Replace with new collet, collet nut or bits
Tool makes a squealing and whistling sound	Faulty bearing assembly or fan is broken.	Entire armature and bearing assembly need to be replaced immediately.

WARRANTY

YOUR PRODUCT IS GUARANTEED FOR A MAXIMUM PERIOD OF 12 MONTHS FROM THE ORIGINAL DATE OF PURCHASE AND IS INTENDED FOR DIY (DO IT YOURSELF) USE ONLY. Warranty excludes consumable parts, (For example, bearings and O-rings, etc.)

30-DAY MONEY BACK GUARANTY

Within the first 30 days of purchase, you are allowed to return your product for a full refund.

30 DAYS TO 90 DAYS (3 MONTHS)

A defective unit will be replaced with a new one in accordance with the terms of this warranty, due to manufacturing fault.

90 DAYS TO 12 MONTHS

Up to 12 months after purchase, we will provide speedy and effective online service.

 **WARNING: The following actions will result in the warranty becoming void.**

- If the tool has been operated on a supply voltage other than that specified on the tool.
- If the tool shows signs of damage or defects caused by or resulting from abuse, accidents or alterations
- Failure to perform maintenance as set out within the user manual
- If the product is disassembled or tampered with in any way

ANY QUESTIONS, PLEASE CONTACT OUR CUSTOMER SERVICE CENTER:

To ensure the quickest response possible, please have the model number and date of purchase available so our customer service representative can answer any questions you may have relating to the warranty policy or procedure.

Radley®

8V CORDLESS MINI ROTARY TOOL KIT

1280-009

8V CORDLESS MINI ROTARY TOOL KIT

OWNER'S MANUAL

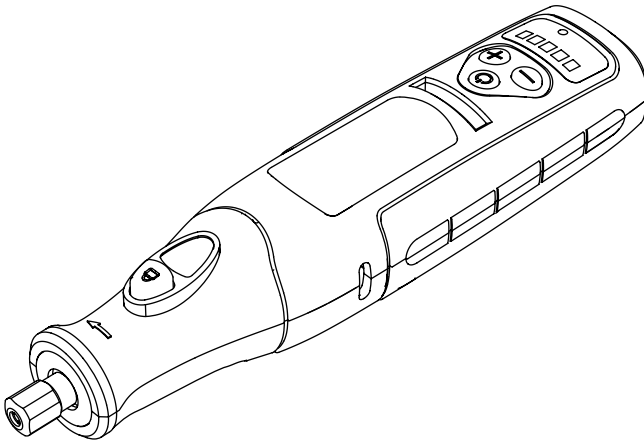

1 Year Limited Warranty on tool

Radley[®]

RADLEY TOOLS
ST. JACOBS, ONTARIO N0B 2N0
© 2021 Home Hardware Stores Limited
1-833-818-4111
Customer Service/Tech Support

1280-009

Made in China

**1 Year
warranty**

This Radley[®] product carries a one (1) year LIMITED warranty against defects in workmanship and materials. See Owner's Manual for full details.



800626

**READ ALL INSTRUCTIONS BEFORE FIRST USE.
KEEP THIS MANUAL FOR FUTURE REFERENCE.
KEEP AWAY FROM CHILDREN.**



**WEAR CSA APPROVED
EYE PROTECTION**



**WEAR EAR
PROTECTION**



**WEAR FACE
PROTECTION**