

BENCHMARK™ MC

7-1/4" CIRCULAR SAW



5 Year Limited Warranty on tool



E114847
JD3596U

**READ ALL INSTRUCTIONS BEFORE FIRST USE.
KEEP THIS MANUAL FOR FUTURE REFERENCE.
KEEP AWAY FROM CHILDREN.**



**WEAR CSA APPROVED
EYE PROTECTION**



**WEAR EAR
PROTECTION**



**WEAR A
FACE MASK**

PRODUCT SPECIFICATIONS

7-1/4" CIRCULAR SAW	
Rating	120V, 60Hz AC
Amperes	15 AMP
Blade Speed	5800 RPM (no load)
Blade Brake	Electronic
Arbor	5/8"
Blade	7 1/4", 24T thin kerf carbide blade
Wood Maximum Cutting Depth	2 3/8 " (60mm) @ 90°
Bevel Angle	1 13/16" (46mm) @ 45°
Weight	13 lbs (5.9Kg)

NEED ASSISTANCE?

Call us on our toll-free customer support line:

1-866-349-8665 (Monday through Friday 9am – 5pm Eastern Standard Time)

- Technical questions
- Replacement parts
- Parts missing from package

TABLE OF CONTENTS

Product Specifications 1

Table of Contents 2

General Safety Instructions 3

Eye, Ear & Lung Protection 3

Electrical Safety 4

Work Area Safety 4

Electrical Safety 4

Personal Safety 4

Power Tool Use and Care 5

Service 6

Specific Safety Rules for 15A Circular Saw 6

Causes & Operator Prevention O-F Kickback 7

Guidelines for Extension Cords 8

Symbols 9

Know Your 7-1/4" Circular Saw 11

Assembly and Operating 12

Installing Blades 12

Setting the Cutting Depth 13

Adjusting the 0° Angle Stop 14

Installing the Rip Guide 14

Live Wire Indicator 15

LED Work-Light 15

Trigger Switch 16

Materials That You Can Cut 16

General Cutting 16

Rip Guide Cutting 17

Plunge Cutting 17

Maintenance 18

Exploded View 19



Parts List 20

Warranty 21

GENERAL SAFETY INSTRUCTIONS

⚠️ WARNING: Before using this tool or any of its accessories, read this manual and follow all Safety Rules and Operating Instructions. The important precautions, safeguards and instructions appearing in this manual are not meant to cover all possible situations. It must be understood that common sense and caution are factors which cannot be built into the product.

EYE, EAR & LUNG PROTECTION

SYMBOL	MEANING
<p>⚠️ DANGER</p> 	<p>ALWAYS WEAR EYE PROTECTION THAT CONFORMS WITH CSA Z94.3 or ANSI SAFETY STANDARD Z87.1</p> <p>FLYING DEBRIS can cause permanent eye damage. Prescription eyeglasses ARE NOT a replacement for proper eye protection. The usage of a safety standard compliant face shield placed over proper safety glasses or goggles can reduce the risk of facial injury.</p> <p>Non-compliant eyewear can cause serious injury if broken during the operation of a power tool.</p>
<p>⚠️ WARNING</p> 	<p>Use hearing protection, particularly during extended periods of operation of the tool, or if the operation is noisy.</p>
<p>⚠️ WARNING</p> 	<p>WEAR A DUST MASK THAT IS DESIGNED TO BE USED WHEN OPERATING A POWER TOOL IN A DUSTY ENVIRONMENT.</p> <p>Dust that is created by power sanding, sawing, grinding, drilling, and other construction activities may contain chemicals that are known to cause cancer, birth defects, or other genetic abnormalities. These chemicals include:</p> <ul style="list-style-type: none"> • Lead from lead-based paints • Crystalline silica from bricks, cement, and other masonry products • Arsenic and chromium from chemically treated lumber <p>The level of risk from exposure to these chemicals varies, according to how often this type of work is performed. In order to reduce exposure to these chemicals, work in a well-ventilated area, and use approved safety equipment, such as a dust mask that is specifically designed to filter out microscopic particles.</p>

ELECTRICAL SAFETY

⚠️ WARNING: To avoid electrical hazards, fire hazards or damage to the tool, use proper circuit protection.

This tool is wired at the factory for 120V AC operation. It must be connected to a 120V AC, 15 A circuit that is protected by a time-delayed fuse or circuit breaker. To avoid shock or fire, replace power cord immediately if it is worn, cut or damaged in any way.

⚠️ WARNING: Read all safety warnings and instructions. Failure to follow the warnings and instructions may result in electric shock, fire and/or serious injury. Save all warnings and instructions for future reference.

WORK AREA SAFETY

Keep work area clean and well lit. Cluttered or dark areas invite accidents.

Do not operate power tools in explosive atmospheres, such as in the presence of flammable liquids, gases or dust. Power tools create sparks which may ignite the dust or fumes.

Keep children and bystanders away while operating a power tool. Distractions can cause you to lose control.

ELECTRICAL SAFETY

Power tool plugs must match the outlet. Never modify the plug in any way. Do not use any adapter plugs with earthed (grounded) power tools. Unmodified plugs and matching outlets will reduce risk of electric shock.

Avoid body contact with earthed or grounded surfaces such as pipes, radiators, ranges and refrigerators. There is an increased risk of electric shock if your body is earthed or grounded.

Do not expose power tools to rain or wet conditions. Water entering a power tool will increase the risk of electric shock.

Do not abuse the cord. Never use the cord for carrying, pulling or unplugging the power tool. Keep cord away from heat, oil, sharp edges or moving parts. Damaged or entangled cords increase the risk of electric shock.

When operating a power tool outdoors, use an extension cord suitable for outdoor use. Use of a cord suitable for outdoor use reduces the risk of electric shock.

If operating a power tool in a damp location is unavoidable, use a residual current device (RCD) protected supply. Use of a ground fault circuit interrupter (GFCI) reduces the risk of electric shock.

PERSONAL SAFETY

Stay alert, watch what you are doing and use common sense when operating a power tool. Do not use a power tool while you are tired or under the influence of drugs, alcohol or medication. A moment of inattention while operating power tools may result in serious personal injury.

Use personal protective equipment. Always wear eye protection. Protective equipment such as dust mask, non-skid safety shoes, hard hat, or hearing protection used for appropriate conditions will reduce personal injuries.

Prevent unintentional starting. Ensure the switch is in the off-position before connecting to power source and/or battery pack, picking up or carrying the tool. Carrying power tools with your finger on the switch or energizing power tools that have the switch on invites accidents.

Remove any adjusting key or wrench before turning the power tool on.

A wrench or a key left attached to a rotating part of the power tool may result in personal injury.

Do not overreach. Keep proper footing and balance at all times. This enables better control of the power tool in unexpected situations.

Dress properly. Do not wear loose clothing or jewellery. Keep your hair, clothing and gloves away from moving parts. Loose clothes, jewellery or long hair can be caught in moving parts.

If devices are provided for the connection of dust extraction and collection facilities, ensure these are connected and properly used. Use of dust collection can reduce dust-related hazards.

POWER TOOL USE AND CARE

Do not force the power tool. Use the correct power tool for your application.

The correct power tool will do the job better and safer at the rate for which it was designed.

Do not use the power tool if the switch does not turn it on and off. Any power tool that cannot be controlled with the switch is dangerous and must be repaired.

Disconnect the plug from the power source and/or the battery pack from the power tool before making any adjustments, changing accessories, or storing power tools. Such preventive safety measures reduce the risk of starting the power tool accidentally.

Store idle power tools out of the reach of children and do not allow persons unfamiliar with the power tool or these instructions to operate the power tool.

Power tools are dangerous in the hands of untrained users.

Maintain power tools. Check for misalignment or binding of moving parts, breakage of parts and any other condition that may affect the power tool's operation. If damaged, have the power tool repaired before use. Many accidents are caused by poorly maintained power tools.

Keep cutting tools sharp and clean. Properly maintained cutting tools with sharp cutting edges are less likely to bind and are easier to control.

Use the power tool, accessories and tool bits etc. in accordance with these instructions, taking into account the working conditions and the work to be performed. Use of the power tool for operations different from those intended could result in a hazardous situation.

Hold power tool by insulated gripping surfaces when performing an operation where the cutting tool may contact hidden wiring or its own cord. Contact with a "live" wire will make exposed metal parts of the tool "live" and shock the operator.

Use clamps or another practical way to secure and support the workpiece to a stable platform. Holding the work by hand or against your body leaves it unstable and may lead to loss of control.

SERVICE

Have your power tool serviced by a qualified repair person using only identical replacement parts. This will ensure that the safety of the power tool is maintained. Have your power tool serviced by a qualified repair person using only identical replacement parts. This will ensure that the safety of the power tool is maintained.

SPECIFIC SAFETY RULES FOR 15A CIRCULAR SAW

 **WARNING: Know your circular saw. Do not plug in the tool until you have read and understand this Instruction Manual. Learn the tool's applications and limitations, as well as the specific potential hazards related to this tool.** Following this rule will reduce the risk of electric shock, fire, or serious injury.



Always wear eye protection. Any power tool can throw foreign objects into your eyes and cause permanent eye damage. ALWAYS wear safety goggles (not glasses) that comply with ANSI safety standard Z87.1. Everyday glasses have only impact resistant lenses. They ARE NOT safety glasses.

 **WARNING: Glasses or goggles not in compliance with ANSI Z87.1 could cause serious injury when they break.**

Always keep hands out of the path of the saw blade. Avoid awkward hand positions where a sudden slip could cause your hand to move into the path of the saw blade.

 **DANGER: Keep hands away from cutting area and the blade. Keep your second hand on the tool.** If both hands are holding the saw, they cannot be cut by the blade.

Do not reach underneath the workpiece. The guard cannot protect you from the blade below the workpiece.

Adjust the cutting depth according to the thickness of the workpiece. Less than a full tooth of the blade teeth should be visible below the workpiece or approximately 3/8" (10 mm).

Never hold piece being cut in your hands or across your leg. Secure the workpiece to a stable platform. It is important to support the work properly to minimize body exposure, blade binding, or loss of control.

Hold the tool by its insulated gripping surfaces when performing an operation where the saw blade may contact hidden wiring or its own cord. Contact with a "live" wire will make exposed metal parts of the tool "live" and shock the operator.

When ripping always use a straight edge guide. This improves the accuracy of cut and reduces the chance of the blade binding.

Always use blades with correct size and shape (diamond versus round) of arbor holes. Blades that do not match the mounting hardware of the saw will run eccentrically, causing loss of control.

Never use damaged or incorrect blade washers or bolt. The blade washers and

bolt were specially designed for your saw, for optimum performance and safety of operation.

CAUSES AND OPERATOR PREVENTION OF KICKBACK

Kickback is a sudden reaction to a pinched, bound or misaligned saw blade, causing an uncontrolled saw to lift up and out of the workpiece toward the operator.

When the blade is pinched or bound tightly by the kerf closing down, the blade stalls and the motor reaction drives the unit rapidly back toward the operator.

If the blade becomes twisted or misaligned in the cut, the teeth at the back edge of the blade can dig into the top surface of the wood causing the blade to climb out of the kerf and jump back toward the operator.

Kickback is the result of saw misuse and/or incorrect operating procedures or conditions and can be avoided by taking proper precautions as given below:

Maintain a firm grip with both hands on the saw and position your arms to resist kickback forces. Position your body to the left or right side of the blade, but not in line with the blade. Kickback could cause the saw to jump backwards, but kickback forces can be controlled by the operator, if proper precautions are taken.

When the blade is binding, or when interrupting a cut for any reason, release the trigger and hold the saw motionless in the material until the blade comes to a complete stop. Never attempt to remove the saw from the work or pull the saw backward while the blade is in motion or kickback may occur. Investigate and take corrective actions to eliminate the cause of blade binding.

When restarting a saw in the workpiece, center the saw blade in the kerf and check that saw teeth are not engaged into the material. If the saw blades are binding, it may walk up or kickback from the workpiece as the saw is restarted.

Support large panels to minimize the risk of blade pinching and kickback. Large panels tend to sag under their own weight. Supports must be placed under the panel on both sides, near the line of cut and near the edge of the panel.

Do not use dull or damaged blades. Unsharpened or improperly set blades produce narrow kerf causing excessive friction, blade binding and kickback.

Use extra caution when making a “plunge cut” into existing walls or other blind areas. The protruding blade may cut objects that can cause kickback.

Check the lower guard for proper closing before each use. Do not operate the saw if the lower guard does not move freely and close instantly. Never clamp or tie the lower guard into the open position. If the saw is accidentally dropped, the lower guard may be damaged. Raise the lower guard with the retracting handle and make sure it moves freely and does not touch the blade or any other part in all depths of cuts.

Check the operation of the lower guard spring. If the guard and the spring are not operating properly, they must be serviced before use. The lower guard may operate sluggishly due to damaged parts, gummy deposits, or a build-up of debris.

The lower guard should be retracted manually only for special cuts such as “plunge cuts” and “compound cuts”. Raise lower guard by retracting handle and as soon as the blade enters the material, the lower guard must be released. For all other sawing, the lower guard should operate automatically.

Always observe that the lower guard is covering the blade before placing saw down on the bench or on the floor. An unprotected, coasting blade will cause the saw to walk backwards, cutting whatever is in its path. Be aware of the time it takes for the blade to stop after the switch is released.

Never operate the saw while it is being carried to another location. The blade guard may be open and potentially cause serious injury.

If the switch fails to turn the saw ON or OFF properly, stop using it immediately and have the saw switch repaired.

Always allow the saw to reach full speed before beginning the cut.

Never use the side of the blade for cutting. When making horizontal cuts, make sure the weight of the tool is not forcing the side of the blade to do the cutting. This will reduce the risk of kickback.

Make sure there are no nails or foreign objects in the area of the workpiece to be cut.

Never lay workpiece on hard surfaces like concrete, stone, etc. The protruding blade may cause tool to jump.

 DANGER: To avoid injury from accidental starting, always remove the plug from the power source before making any adjustments and before installing or removing a saw blade.

When replacing the blade, make sure the replacement blade is 7 1/4" in diameter and is rated for 7,000 RPM. Installing an incorrect blade will result in possible injury and poor cutting action.

After changing a blade or making adjustments make sure the blade clamp screw is securely tightened. Loose blades and adjustment devices will be violently thrown.

Never touch the blade during or immediately after use. After use the blade is too hot to be safely touched with bare hands.

GUIDELINES FOR EXTENSION CORDS

Make sure your extension cord is the proper size. When using an extension cord, be sure to use one heavy enough to carry the current the tool will draw. An undersized cord will cause a drop in line voltage resulting in loss of power and overheating. The table on at right shows the correct size to use according to cord length and nameplate ampere rating. If in doubt, use the next heavier gauge. The smaller the gauge number the heavier the cord.

Be sure your extension cord is properly wired and in good condition. Always replace a damaged extension cord or have it repaired by a qualified electrician before using it. Protect your extension cord from sharp objects, excessive heat and damp or wet areas.

Use a separate electrical circuit for your power tools. This circuit must not be less than 14 gauge wire and should be protected with either a 15A time delay fuse or circuit breaker. Before connecting the power tool to the power source, make sure the switch is in the OFF position and the power source is the same as indicated on the nameplate. Running at lower voltage will damage the motor.

⚠️ WARNING: Repair or replace damaged or worn extension cords immediately
 Select the appropriate extension cord gauge and length using the chart to your right

When operating a power tool outdoors, use an outdoor extension cord marked “W-A” or “W”. These cords are rated for outdoor use and reduce the risk of electric shock.







⚠️ WARNING: Keep the extension cord clear of the working area. Position the cord so it will not get caught on the workpiece, tools or any other obstructions while you are working with the power tool



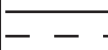

MINIMUM GAUGE (AWG) EXTENSION CORDS (120 V use only)

Ampere Rating		Total Length in Feet			
More Than	Not More Than	7.5 m (25')	15 m (50')	30 m (100')	45 m (150')
0	6	18	16	16	14
6	10	18	16	14	12
10	12	16	16	14	12
12	16	14	12	Not Applicable	

SYMBOLS

⚠️ WARNING: Some of the following symbols may appear on the saw. Study these symbols and learn their meaning. Proper interpretation of these symbols will allow for more efficient and safer operation of this tool.

V	VOLTS		Three-phase alternating current with neutral
A	Amperes		Direct current
Hz	Hertz	n₀	No load speed
W	Watts		Alternating or direct current
kW	Kilowatts		Class II construction
µF	Microfarads		Splash-proof construction
L	Litres		Watertight construction
kg	Kilograms		Protective grounding at grounding terminal, Class I tools

H	Hours	.../min	Revolutions or reciprocations per minute
N/cm²	Newtons per square centimeter	∅	Diameter
Pa	Pascals	0	Off position
OPM	Oscillations per minute	→	Arrow
MIN	Minutes	⚠	Warning symbol
S	Seconds		Wear your safety glasses
 or ac.	Alternating current		Wear a dust mask
	Three-phase alternating current		Wear hearing protection



This symbol designates that this tool is listed with U.S. requirements by MET Laboratories, Inc. UL62841-1, UL62841-2-5; CSA C22.2#62841-1, CSA C22.2#62841-2-5.

KNOW YOUR 15A 7-1/4" CIRCULAR SAW

⚠️ WARNING: Before starting please read, understand, and apply the safety instructions.

FUNCTIONS

- | | | |
|---------------------------------|-----------------------|---------------------------------|
| 1. Main Handle | 6. 45° Bevel Stop | 13. Upper Blade Guard |
| 2. Front Handle | 7. Sole Plate | 14. Trigger Switch |
| 3. LED Work-Light | 8. 6 mm Hex Key | 15. Live Wire Indicator |
| 4. Bevel Gauge Adjustment Lever | 9. Rip Guide | 16. Cutting Depth Locking Lever |
| 5. Edge Guide Adjustment Knob | 10. Blade Screw | |
| | 11. Lower Blade Guard | |
| | 12. Blade Guard Lever | |

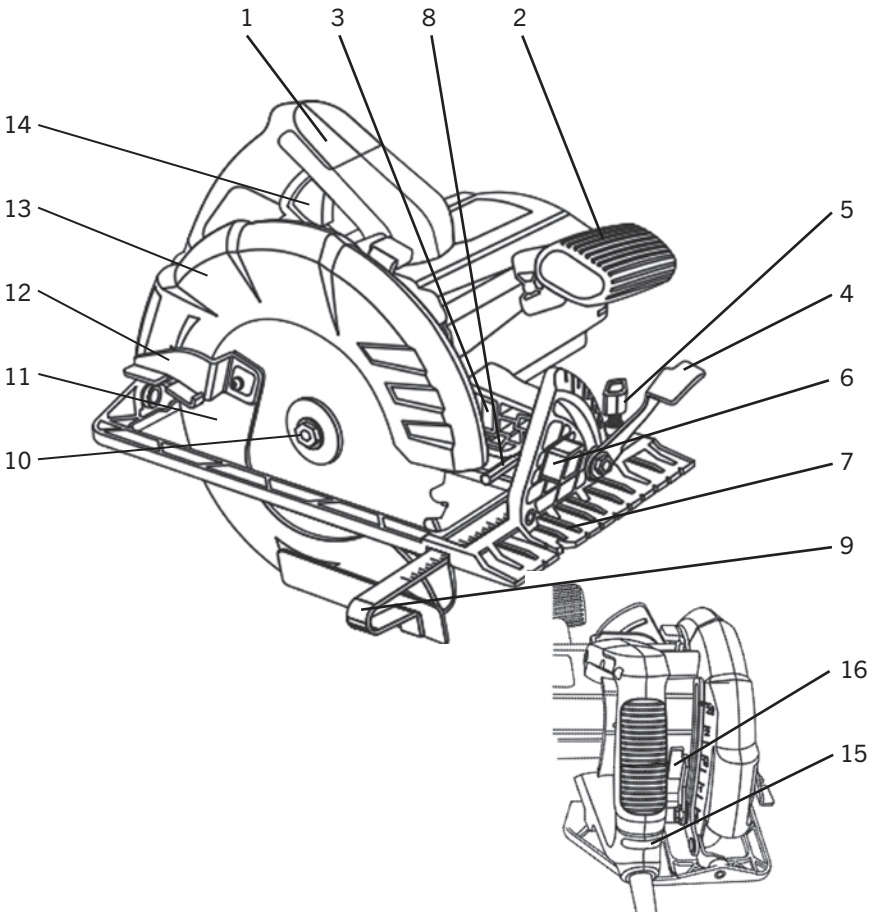

ASSEMBLY AND OPERATING

INSTALLING BLADES

⚠ WARNING: Always remove the plug from the power source before installing or removing a blade or adjusting the saw in any way.

1. Place a clean piece of cardboard on a workbench to protect the blade and the workbench.
2. Lift the depth adjustment lever (1) and lower the sole plate (2) as far as it will go (Fig. 1). Press down on the depth adjustment lever to lock the sole plate in its lower position.
3. Rotate the lower blade guard lever (3) clockwise toward the front of the saw and carefully place the saw on the cardboard.
4. Insert the 6 MM blade hex key into the blade screw (4).
5. Rotate the blade hex screw counter- clockwise and remove both the blade screw and the outer blade flange (5).

NOTE: If the arbor turns with the blade screw, press on the blade locking lever (6) and slowly rotate the blade screw until the locking lever engages the spindle (Fig. 2).

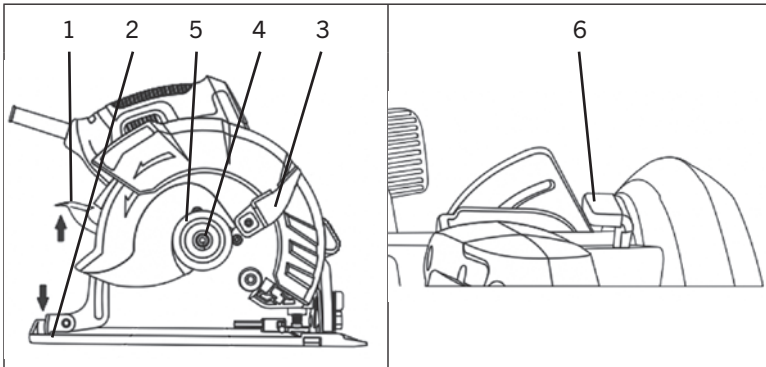

FIG. 1

FIG. 2

NOTE: Do NOT remove the inner blade flange (7) from the arbor (8). If it should fall off, make sure the THICKER boss on the washer is facing the motor (Fig. 3).

6. Slide the blade upward through the slot in the sole plate and place the blade hole onto the arbor.

NOTE: Make sure the blade teeth are pointing toward the front of the saw.

7. Place the outer blade flange (5) onto the arbor and thread the blade screw (4) into the arbor.
8. Tighten the blade screw.

NOTE: Press on the blade locking lever (6 Fig. 2) and slowly rotate the blade screw clockwise until the locking lever engages the spindle. Continue to turn the blade screw clockwise until the blade is firmly tightened onto the spindle.

When installing a new blade, make sure you follow these precautions:

- a) Make sure the teeth at the bottom of the blade are pointing toward the front of the saw.
- b) Check the inner flange washer to make sure the thicker boss is pointing toward the motor.
- c) Place the outer flange washer so the flat surface is against the blade and the rectangular hole properly mated with the arbor.
- d) Make sure the flanged blade screw is NOT cross threaded and is fully tightened with the wrench provided.
- e) Before turning the saw ON, carefully rotate the blade by hand to make sure it does not wobble.

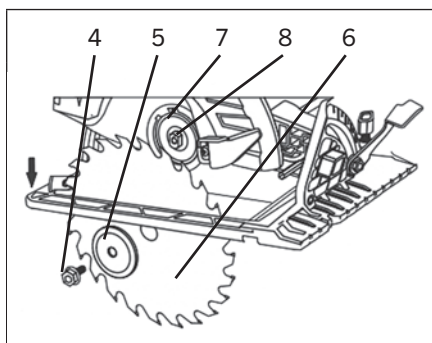

FIG. 3

SETTING THE CUTTING DEPTH

The cutting depth of the blade should be set to suit the thickness of the material being cut. The cutting depth should be approximately 1/8" (3 mm) greater than the thickness of the material being cut.

1. Lift the depth adjustment locking lever (1) upward (Fig. 4).
2. Pull the sole plate (2) downward until the correct amount of the blade is protruding below the sole plate.

NOTE: The depth indicator (3) will identify the relative depth of cut on the scale (4).

3. Lock the sole plate at the correct depth by pushing the depth control locking lever downward.

NOTE: Make a test cut on a scrap workpiece to verify the depth setting.

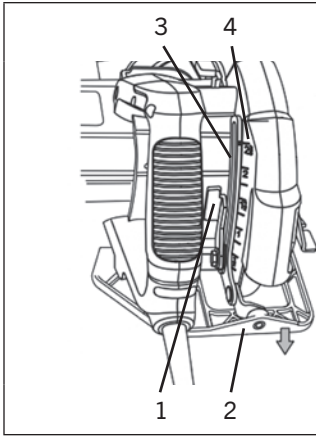

FIG. 4

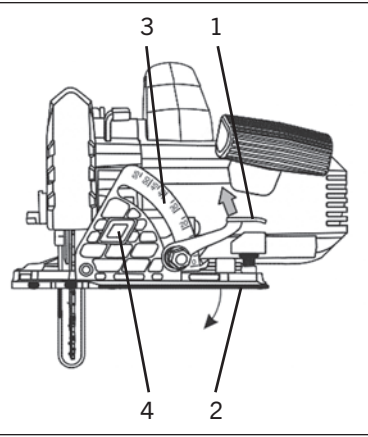

FIG. 5

ADJUSTING THE 0° ANGLE STOP

1. Set the bevel angle to 0° (1) (Fig. 6).
2. Use a carpenter's square to check the angle between the blade and the sole plate.
3. If the angle is NOT 90°, use a 2.5 mm hex key and adjust the 0° set screw (2) so the angle is 90° when the 0° stop contacts the set screw.

NOTES: Make a test cut to verify that the saw is cutting at 90°

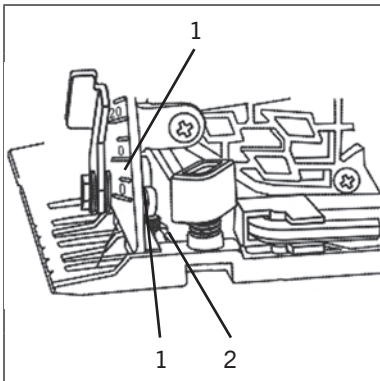

FIG. 6

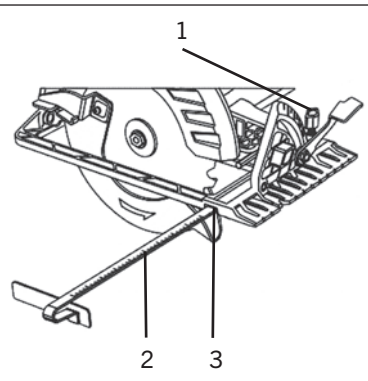

FIG. 7

INSTALLING THE RIP GUIDE

1. Loosen the rip guide adjusting knob (1) (Fig. 7).
2. Slide the rip guide rod (2) into the rip guide slot (3). Continue to slide the rip guide rod across the sole plate and into the rip guide slot under the rip guide adjusting knob.

3. Adjust the rip guide shoe to the correct distance from the blade and tighten the rip guide adjusting knob.

LIVE WIRE INDICATOR

The live wire indicator (1) will turn ON when the plug is inserted into a "live" 110V receptacle (Fig. 8). If the live wire indicator fails to turn on, this indicates the plug is not inserted into a "live" receptacle.

LED WORK-LIGHT

The LED work-light (1) will turn ON automatically when the tool is plugged into the power supply (Fig. 9). It will turn OFF when the plug is removed from the power supply.

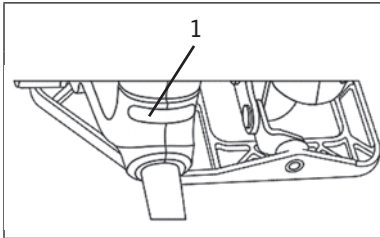

FIG. 8

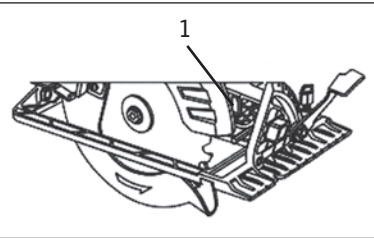

FIG. 9

⚠ WARNING: For safety reasons, the operator must read the sections of this Owner's Manual entitled "GENERAL SAFETY WARNINGS", "POWER TOOL SAFETY", "SPECIFIC SAFETY RULES", "EXTENSION CORD SAFETY" and "SYMBOLS" before using this circular saw.

Verify the following every time the circular saw is used:

1. The blade is tight and sharp.
2. All adjustments are tight.
3. The workpiece is properly secured.
4. Safety glasses and hearing protection are being worn.

Failure to adhere to these safety rules can greatly increase the chances of serious injury.

TRIGGER SWITCH

1. To turn the saw ON, squeeze the trigger switch (1) (Fig. 9).

⚠ WARNING: Never carry the saw with your finger on the trigger switch. The saw could be accidentally started and cause severe personal injury.

2. To turn the saw OFF, release the trigger switch.

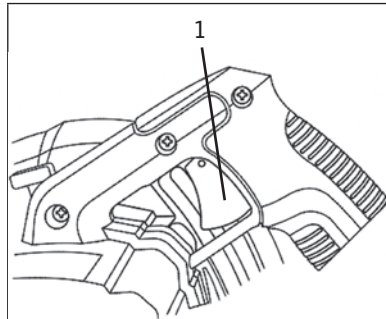

FIG. 9

MATERIALS THAT YOU CAN CUT

The circular saw is a versatile saw that allows you to cut many different types of materials. Some of the materials include:

- Wood products such as lumber, hardwood, plywood, composite board and paneling
- Drywall
- Masonite and plastic

NOTE: There are several different types of blades available. Generally, blades with carbide-tipped teeth cut better and stay sharp longer. Tooth count and configuration are also important. High tooth counts cut slower, and are best suited for making smooth cuts on thinner materials such as paneling. Use the correct blade for your application.

GENERAL CUTTING

1. Make any adjustments to the saw before installing the blade. Adjustments include cutting depth, cutting angle and rip guide (if installed).
2. Clearly mark the workpiece to locate the position of the cut.
3. Hold a smaller workpiece with a vise. Clamp a larger workpiece to a workbench or table.

⚠ DANGER: Any workpiece that is not adequately clamped in place may come loose and cause serious injury. Never hold the workpiece in your hand.

4. Make sure there are no nails, screws, clamps or foreign materials in the path of the saw blade.

5. With both hands firmly gripping the saw, and with the blade NOT in contact with the surface to be cut, start the saw by squeezing the trigger switch.
6. Once the saw has reached full speed, place the front edge of the sole plate on the workpiece and gradually bring the moving blade into contact with the workpiece at the appropriate location.

NOTE: To align the saw blade with the cutting mark, use the guide marks on the front of the sole plate (Fig. 10). Use the 0° cutting mark (1) for right angle cuts. Use only the 45° mark (2) for 45° cuts. The 45° mark will allow for the extra material needed for the angle cut. Always make a test cut on a scrap workpiece before cutting the new material.

⚠ WARNING: Do not force the circular saw. Use only enough force to keep the blade cutting at full speed. Excessive pressure on the blade will cause it to slow down and overheat, resulting in poor cut quality and damage to the motor.

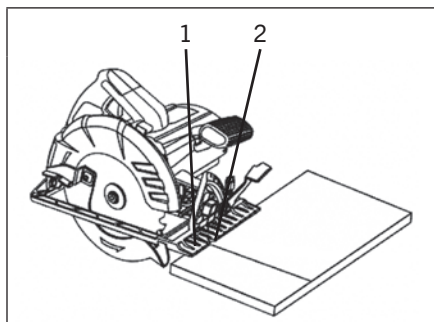

FIG. 10

RIP GUIDE CUTTING

1. Set the rip guide foot at the required width (Fig. 7).

NOTE: When starting the cut, make sure the blade is parallel to the edge of the workpiece and the rip guide foot is against the edge of the workpiece.

2. Proceed with the cut as outlined in “GENERAL CUTTING” above.

NOTE: As you move the saw through the workpiece, make sure the guide foot stays in contact with the workpiece.

PLUNGE CUTTING

⚠ WARNING: To avoid loss of control, damage to the blade or damage to the workpiece, always use extreme caution when making plunge cuts. It is not recommended to plunge cut any material other than wood.

1. To plunge cut inside the edges of a workpiece, clearly mark the cutting line on the workpiece.
2. Set the bevel angle to 0° (Fig. 5).

3. Lift the cutting depth locking lever upward to allow the blade to rise above the bottom of the sole plate so the blade will NOT contact the workpiece (Fig. 4). Do NOT lock the cutting depth locking lever.
4. Set the saw on the workpiece (1) so the sole plate is flat on the workpiece. (Fig. 11).
5. Open the blade guard by rotating the blade guard lever (2) forward.
6. Align the saw blade with the cutting line (3) using the 0° cutting mark on the sole plate.

NOTE: Make sure the saw blade is inside the area to be cut out.

7. Start the saw and slowly lower the blade onto the workpiece while holding the blade guard lever forward to allow the blade to cut into the workpiece (Fig. 12). Allow the blade to cut through the wood.
8. Continue lowering the blade into the workpiece until the full cutting depth has been achieved. Continue sawing toward the cutting line and complete the cut as required.

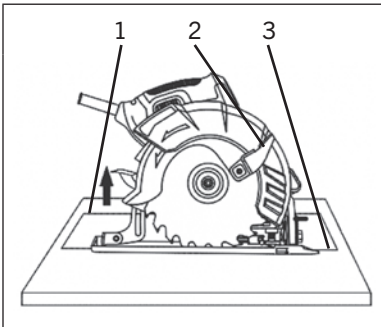

FIG. 11

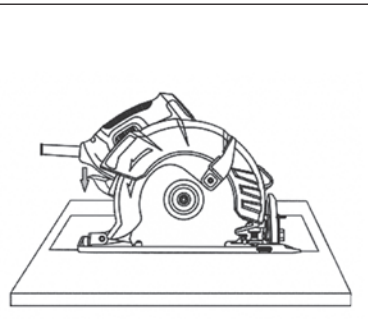

FIG. 12

MAINTENANCE

⚠️ WARNING: When servicing, use only identical replacement parts. The use of any other part may create a hazard or cause product damage.

DO NOT use solvents when cleaning plastic parts. Plastics are susceptible to damage from various types of commercial solvents and may be damaged by their use. Use a clean cloth to remove dirt, dust, oil, grease etc.

⚠️ WARNING: Do not allow brake fluids, gasoline, petroleum-based products, penetrating oils, etc. to come into contact with plastic parts. They contain chemicals that can damage, weaken or destroy plastic.

DO NOT abuse power tools. Abusive practices can damage the tool and the workpiece.

⚠️ WARNING: DO NOT attempt to modify tools or create accessories. Any such alteration or modification is misuse and could result in a hazardous condition leading to possible serious injury. It will also void the warranty.

It has been found that electric tools are subjected to accelerated wear and possible premature failure when they are used on fiberglass boats and sports cars, wallboard, spackling compounds or plaster. The chips and grindings from these materials are highly abrasive to electric tool parts such as bearings, brushes, commutators, etc. Consequently, it is not recommended that this tool be used for extended work on any fiberglass material, wallboard, spackling compounds or plaster. During any use on these materials it is extremely important that the tool is cleaned frequently by blowing it out with an air jet.

⚠ WARNING: Always wear safety goggles or safety glasses with side shields during all cutting operations. It is critical that you also wear safety goggles or safety glasses with dust out of the circular saw with an air jet. Failure to take these safety precautions could result in permanent eye or lung damage.

If the motor brushes require replacement, contact the toll-free customer support line: 1-866-349-8665 Monday – Friday from 9am to 5pm Eastern Standard Time

LUBRICATION

All of the bearings in this tool are lubricated with a sufficient amount of high-grade lubricant for the life of the unit under normal operating conditions. Therefore, no further lubrication is required.

EXPLODED VIEW

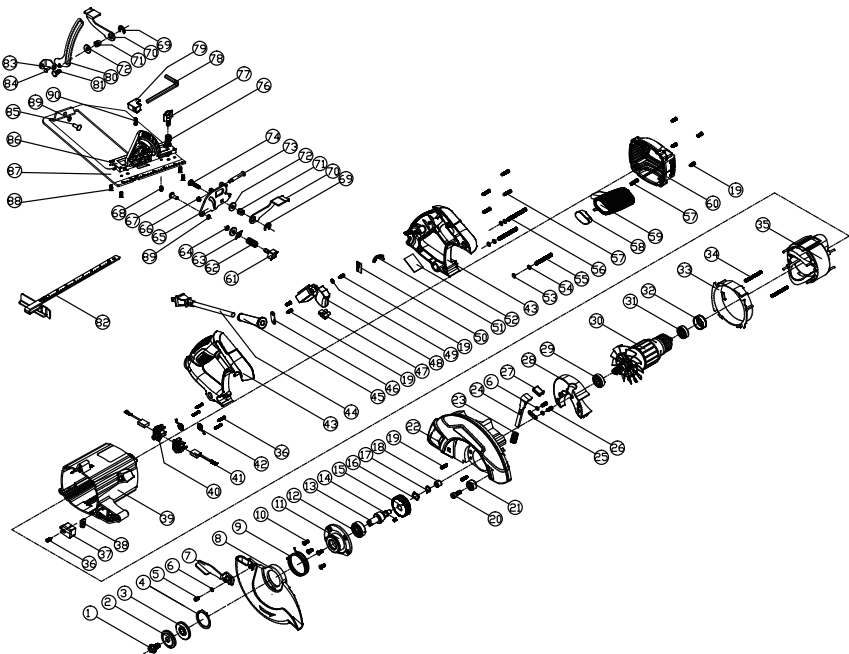

PARTS LIST

⚠️ WARNING: When servicing, use only original equipment replacement parts. The use of any other parts may create a safety hazard or cause damage to the circular saw.

Always order by key number.

KEY #	PART #	PART NAME / QUANTITY	KEY #	PART #	PART NAME / QUANTITY
1	4050050006	Hex Screw M8x16 /1	30	1010120014	Motor Rotor /1
2	2040210039	Outer Flange /1	31	4010010014	Bearing 629 2RS /1
3	2040210003	Inner Flange /1	32	3140040012	Bearing Sleeve 629 /1
4	4100020009	Circlip for Shaft \varnothing 36 /1	33	3150050074	Air Deflector /1
5	4020010001	Screw M4x8 /1	34	4030010124	Tapping Screw 5x45 /2
6	4040030001	Spring Washer 4mm /3	35	1020120017	Motor Stator /1
7	2030030231	Lower Guard Lever /1	36	4030010034	Tapping Screw 3x16 /5
8	2020080040	Lower Guard /1	37	3160060060	Lamp Cover /1
9	2050050043	Lower Guard Spring /1	38	1220040022	Lamp LED /1
10	4020020005	Screw M5x12 /4	39	3011120009	Motor Housing /1
11	2020150070	Gear Cover /1	40	1230030013	Carbon Brush Box /2
12	4010010081	Bearing 6201 2RS /1	41	1230010123	Carbon Brush /2
13	2040040096	Output Shaft /1	42	2050020028	Volute Spring /2
14	4120010003	Flat Key /1	43	3120070111	Handle /1
15	2040080031	Output Gear /1	44	1190030051	UI Power Cable /1
16	4040020002	Spring Washer \varnothing 12 /1	45	3140010080	Cable Guard /1
17	4100020008	Circlip for Shaft \varnothing 12 /1	46	2030050003	Cable Plate /1
18	4010020003	Needle Bearing Hk0810 /1	47	1250010007	Wiring Terminal /1
19	4030010096	Tapping Screw 4x12 /10	48	1062020054	Switch /1
20	4020080007	Hex Head Screw M6x16 /1	49	4040010025	Flat Washer \varnothing 4x9 /1
21	3140090020	Rubber Cover for Locking Board /1	50	1130040050	Power up display lamp circuit board /1
22	2020020042	Gear Housing /1	51	3160060059	Electric Indicator Lamp /1
23	2050040051	Spindle Lock Spring /1	52	1130090010	Lamp Breadboard /1
24	2030250013	Spindle Lock /1	53	4040010012	Flat Washer \varnothing 5 /3
25	2030160122	Spindle Lock Plate /1	54	4040030003	Spring Washer \varnothing 5 /3
26	4020010006	Screw M4x12 /2	55	4020010138	Screw M5x45 /1
27	3140070020	Spindle Lock Rubber /1	56	4020010035	Screw M5x60 /2
28	3150050080	Export Air Loop /1	57	4030010106	Tapping Screw 4 X 19 /5
29	4010010055	Bearing 6001 2RS /1	58	3160090088	Auxiliary Handle Cover /1

KEY #	PART #	PART NAME / QUANTITY	KEY #	PART #	PART NAME / QUANTITY
59	3120070110	Auxiliary Handle /1	74	4050040005	Cup Head Square Neck Bolt M6x25 / 1
60	3160010060	Motor Cover /1	75		
61	1160010019	Angle Button /1	76	2050060010	Guide Ruler Spring / 1
62	2050040055	Angle Button Spring /1	77	1160030071	Guide Ruler Knob / 1
63	3150240023	Angle Button Plate /1	78	6140020015	Hex Key / 1
64	4100050005	Circlip For Shaft \varnothing 5 /1	79	31501600182	Hex Key Hold / 1
65	2030100059	Bevel Support /1	80	2030100058	Depth Adjusting Support / 1
66	4060090001	Hex Lock Nu /1	81	4050040007	Cup Head Square Neck Bolt M6x15 /1
67	4090040015	Rivet \varnothing 6x15 /2	82	6220040014	Guide Ruler /1
68	4020150006	Screw M5x10 /1	83	2030100051	Depth adjusting rack bracket / 1
69	4100050004	Circlip For Shaft \varnothing 9 /2	84	4090040004	Rivet \varnothing 6x8 / 1
70	2030030255	Depth Lever /2	85	4090040021	Rivet \varnothing 6x10 / 1
71	2040150028	Slotted Nut / 2	86	2020060017	Angle scale / 1
72	2030020017	Flat Washer 6mm / 3	87	2020120052	Base / 1
73	2040140001	M5x39 Special Screw / 1	88	4020020020	M4x10 Special Screw /4
			89	2030020142	Flat mat 6 / 2
			90	4030010179	Screw ST4x10 /1

WARRANTY

If this Benchmark tool fails due to a defect in material or workmanship within five years from the date of purchase, return it to any Home Hardware store with the original bill of sale for exchange. 3-year warranty for the battery and charger. This warranty does not include expendable parts including but not limited to blades, brushes, belts, light bulbs.

This warranty covers defects in material or workmanship only. It does not cover normal wear and tear, failure due to abuse/misuse, or defects caused by careless or accidental mishandling. If this Benchmark product is used for commercial or rental purposes, this warranty does not apply.

7-1/4" CIRCULAR SAW



5 Year Limited Warranty on tool

BENCHMARKTM_{MC}

BENCHMARK TOOLS CANADA
ST. JACOBS, ONTARIO N0B 2N0
© 2020 Home Hardware Stores Limited

CUSTOMER SERVICE/TECH SUPPORT
1-866-349-8665

1265-000

Made in China



* This BenchmarkTM product carries a five (5) year LIMITED warranty against defects in workmanship and materials. See Owner's Manual for full details.



E114847
JD3596U

**READ ALL INSTRUCTIONS BEFORE FIRST USE.
KEEP THIS MANUAL FOR FUTURE REFERENCE.
KEEP AWAY FROM CHILDREN.**



**WEAR CSA APPROVED
EYE PROTECTION**



**WEAR EAR
PROTECTION**



**WEAR A
FACE MASK**