

BENCHMARKTM_{MC}

20V MAX[†] BRUSHLESS 1/2" HAMMER DRILL



Item # 1239-219



5 Year Limited Warranty on drill

3 Year Limited Warranty on Battery and Charger



JD6360C

**READ ALL INSTRUCTIONS BEFORE FIRST USE.
KEEP THIS MANUAL FOR FUTURE REFERENCE.
KEEP AWAY FROM CHILDREN.
SEE NEXT PAGE FOR CRITICAL TOOL RELATED
PRECAUTIONS.**

[†] Maximum initial battery voltage (measured without a load)
is 20 volts. Normal voltage is 18 volts.



**WEAR CSA APPROVED
EYE PROTECTION**



**WEAR EAR
PROTECTION**



**WEAR A
FACE MASK**

PRODUCT SPECIFICATIONS

| HAMMER DRILL | |
|--------------------------------|-----------------------------------|
| Variable speed ranges | 0–400 RPM / 0–1,650 RPM (no load) |
| Impact rate | 0-6,000/0-24,750 BPM |
| Torque clutch positions | 18 + drill mode + hammer mode |
| Chuck size | 1/2" (13mm) keyless |
| Max torque | 354 in/lbs. |
| Max drilling capacity in wood | 1" (25 mm) |
| Max drilling capacity in metal | ½" (13 mm) |
| Tool operating weight | 1.49 kg (3.28 lbs) |

| BATTERY AND CHARGER | |
|----------------------------|--|
| Battery voltage | 20V 2.5 Ah Li-ion (Maximum charged battery voltage, measured without load, is 20V with a nominal value of 18V) |
| Charge time | Up to 75 minutes |

| REPLACEMENT PARTS AVAILABLE AT HOME HARDWARE | |
|---|---|
| Replacement battery | HH #5350-023 (2.5Ah) HH #5350-011 (4Ah) HH #5350-012 (5Ah) |
| Replacement charger | HH #5350-010 (2.4A) HH #5350-022 (6A Fast) |

| CRITICAL TOOL RELATED PRECAUTIONS | |
|---|--|
| Batteries must be fully charged before first use and must be charged/stored indoors in a cool dry environment. Exposure to temperature extremes will reduce battery performance and lifespan. | |
| READ ALL SAFETY, WARNING, PRECAUTIONS AND MAINTENANCE INFORMATION PROVIDED IN THIS MANUAL. | |

NEED ASSISTANCE?

Call us on our toll-free customer support line:
1-866-349-8665 (Monday through Friday 9am – 5pm Eastern Standard Time)

- Technical questions
- Replacement parts
- Parts missing from package

TABLE OF CONTENTS

Product Specification 1

Table Of Contents 2

General Safety Warnings 3-6

Specific Safety Rules 6-7

Battery & Charger Safety 7-10

Battery Pack Recycling 10

Safety Symbols 11

Know Your Cordless 20v 2vsr Hammer Drill 12

Assembly And Operating 13-21

Maintenance 22

Exploded View 23

Parts List 24-25











Warranty 26

GENERAL SAFETY WARNINGS

WARNING:

Before using this tool or any of its accessories, read this manual and follow all Safety Rules and Operating Instructions. The important precautions, safeguards and instructions appearing in this manual are not meant to cover all possible situations. It must be understood that common sense and caution are factors which cannot be built into the product.

EYE, EAR & LUNG PROTECTION

| SYMBOL | MEANING |
|---|---|
|  DANGER   | <p>ALWAYS WEAR EYE PROTECTION THAT CONFORMS WITH CSA Z94.3 or ANSI SAFETY STANDARD Z87.1</p> <p>FLYING DEBRIS can cause permanent eye damage. Prescription eyeglasses ARE NOT a replacement for proper eye protection.</p> <p>Non-compliant eyewear can cause serious injury if broken during the operation of a power tool.</p> |
|  WARNING  | <p>Use hearing protection, particularly during extended periods of operation of the tool, or if the operation is noisy.</p> |
|  WARNING  | <p>WEAR A DUST MASK THAT IS DESIGNED TO BE USED WHEN OPERATING A POWER TOOL IN A DUSTY ENVIRONMENT.</p> <p>Dust that is created by power sanding, sawing, grinding, drilling, and other construction activities may contain chemicals that are known to cause cancer, birth defects, or other genetic abnormalities. These chemicals include:</p> <ul style="list-style-type: none"> • Lead from lead-based paints • Crystalline silica from bricks, cement, and other masonry products • Arsenic and chromium from chemically treated lumber. <p>The level of risk from exposure to these chemicals varies, according to how often this type of work is performed. In order to reduce exposure to these chemicals, work in a well-ventilated area, and use approved safety equipment, such as a dust mask that is specifically designed to filter out microscopic particles.</p> |
|  WARNING  | <p>To avoid electrical hazards, fire hazards or damage to the tool, use proper circuit protection.</p> <p>This battery charger is wired at the factory for 120 V AC operations. It must be connected to a 120 V AC, 15 A circuit that is protected by a time-delayed fuse or circuit breaker. To avoid shock or fire, replace power cord immediately if it is worn, cut or damaged in any way.</p> |
|  WARNING  | <p>Ventilation openings in batteries and chargers must always be open to allow cooling air to circulate freely. Air vents that are blocked, restricted, or covered may result in the battery or charger overheating. Overheating may lead to damage to the tool or cause a fire, resulting in possible serious injury.</p> |

 **WARNING:** Read all safety warnings and all instructions. Failure to follow the warnings and instructions may result in electric shock, fire and/or serious injury.

Save all warnings and instructions for future reference.

The term "power tool" in the warnings refers to your mains-operated (corded) power tool or battery-operated (cordless) power tool.

WORK AREA SAFETY

Keep work area clean and well lit. Cluttered or dark areas invite accidents.

Do not operate power tools in explosive atmospheres, such as in the presence of flammable liquids, gases or dust. Power tools create sparks which may ignite the dust or fumes.

Keep children and bystanders away while operating a power tool. Distractions can cause you to lose control.

ELECTRICAL SAFETY

Power tool plugs must match the outlet. Never modify the plug in any way.

Do not use any adapter plugs with earthed (grounded) power tools. Unmodified plugs and matching outlets will reduce risk of electric shock.

Avoid body contact with earthed or grounded surfaces such as pipes, radiators, ranges and refrigerators. There is an increased risk of electric shock if your body is earthed or grounded.

Do not expose power tools to rain or wet conditions. Water entering a power tool will increase the risk of electric shock.

Do not abuse the cord. Never use the cord for carrying, pulling or unplugging the power tool. Keep cord away from heat, oil, sharp edges or moving parts. Damaged or entangled cords increase the risk of electric shock.

When operating a power tool outdoors, use an extension cord suitable for outdoor use. Use of a cord suitable for outdoor use reduces the risk of electric shock.

If operating a power tool in a damp location is unavoidable, use a residual current device (RCD) protected supply. Use of a ground fault circuit interrupter (GFCI) protected supply. Use of a ground fault circuit interrupter (GFCI) reduces the risk of electric shock.

PERSONAL SAFETY

Stay alert, watch what you are doing and use common sense when operating a power tool. Do not use a power tool while you are tired or under the influence of drugs, alcohol, or medication. A moment of inattention while operating power tools may result in serious personal injury.

Use personal protective equipment. Always wear eye protection. Protective equipment such as dust mask, non-skid safety shoes, hard hat, or hearing protection used for appropriate conditions will reduce personal injuries.

Prevent unintentional starting. Ensure the switch is in the off position before connecting to power source and/or battery pack, picking up or carrying the tool. Carrying power tools with your finger on the switch or energizing power tools that have the switch on invites accidents.

Remove any adjusting key or wrench before turning the power tool on.

A wrench or a key left attached to a rotating part of the power tool may result in personal injury.

Do not overreach. Keep proper footing and balance at all times. This enables better control of the power tool in unexpected situations.

Dress properly. Do not wear loose clothing or jewellery. Keep your hair, clothing, and gloves away from moving parts. Loose clothes, jewellery or long hair can be caught in moving parts.

If devices are provided for the connection of dust extraction and collection facilities, ensure these are connected and properly used. Use of dust collection can reduce dust-related hazards.

POWER TOOL USE AND CARE

Do not force the power tool. Use the correct power tool for your application.

The correct power tool will do the job better and safer at the rate for which it was designed.

Do not use the power tool if the switch does not turn it on and off. Any power tool that cannot be controlled with the switch is dangerous and must be repaired.

Disconnect the plug from the power source and/or the battery pack from the power tool before making any adjustments, changing accessories, or storing power tools. Such preventive safety measures reduce the risk of starting the power tool accidentally.

Store idle power tools out of the reach of children and do not allow persons unfamiliar with the power tool or these instructions to operate the power tool. Power tools are dangerous in the hands of untrained users.

Maintain power tools and accessories. Check for misalignment or binding of moving parts, breakage of parts and any other condition that may affect the power tool's operation. If damaged, have the power tool repaired before use. Many accidents are caused by poorly maintained power tools.

Keep cutting tools sharp and clean. Properly maintained cutting tools with sharp cutting edges are less likely to bind and are easier to control.

Use the power tool, accessories, and tool bits etc. in accordance with these instructions, taking into account the working conditions and the work to be performed. Use of the power tool for operations different from those intended could result in a hazardous situation.

Hold power tools by insulated gripping surfaces when performing an operation where cutting tool may contact hidden wiring or its own cord. Contact with a "live" wire will make exposed metal parts of the tool "live" and shock the operator.

Keep handles and grasping surfaces dry, clean and free from oil and grease. Slippery handles and grasping surfaces do not allow for safe handling and control of the tool in unexpected situations.

SAFETY INSTRUCTIONS WHEN USING LONG DRILL BITS

• **Never operate at higher speed than the maximum speed rating of the drill bit.**

At higher speeds, the bit is likely to bend if allowed to rotate freely without contacting the workpiece, resulting in personal injury.

- **Always start drilling at low speed and with the bit tip in contact with the workpiece.** At higher speeds, the bit is likely to bend if allowed to rotate freely without contacting the workpiece, resulting in personal injury.
- **Apply pressure only in direct line with the bit and do not apply excessive pressure.** Bits can bend causing breakage or loss of control, resulting in personal injury.

SPECIFIC SAFETY RULES

⚠ WARNING: Know your cordless hammer drill. Do not plug in the charger or install the battery in the tool until you have read and understand this Instruction Manual. Learn the tool's applications and limitations, as well as the specific potential hazards related to this tool. Following this rule will reduce the risk of electric shock, fire, or serious injury.



Always wear eye protection. Any power tool can throw foreign objects into your eyes and cause permanent eye damage. ALWAYS wear safety goggles (not glasses) that comply with ANSI safety standard Z87.1. Everyday glasses have only impact resistant lenses. They ARE NOT safety glasses.

⚠ WARNING: Glasses or goggles not in compliance with ANSI Z87.1 could cause serious injury when they break.

⚠ WARNING: Always use a safety shield, hearing protection and dust mask when drilling concrete.

⚠ WARNING: To avoid fire or toxic reaction, never use gasoline, naphtha, acetone, lacquer thinner or similar highly volatile solvents to clean the tool.

⚠ WARNING: Use only accessories that are recommended for this cordless drill. Follow the instructions that accompany the accessories. The use of improper accessories may result in injury to the operator or damage to the tool.

⚠ WARNING: If any part is missing or damaged, do not plug the tool into the power source or install any accessory until the missing or damaged part is replaced.

Do not drill material too small to be securely held.

Always keep hands out of the path of the drill bit. Avoid awkward hand positions where a sudden slip could cause your hand to move into the path of the drill bit.

Secure the workpiece. Use clamps or a vice to hold the workpiece. It is safer than using your hand and it frees both hands to operate the tool.

Make sure there are no nails or foreign objects in the part of the workpiece to be drilled.

Disconnect battery pack from tool before making any assembly, adjustments or changing accessories. Such preventative measures reduce the risk of starting the tool accidentally.

Do not install or use any drill bit that exceeds 7" (17.5 cm) in length or extends more than 6" (15 cm) beyond the chuck jaws. They can bend or break suddenly.

Before starting the operation, jog the drill switch to make sure the drill bit does not wobble or vibrate.

Do not use fly cutters or multiple-part hole cutters, because they can come apart or become unbalanced during use.

Make sure the spindle has come to a complete stop before touching the chuck or attempting to change the drill bit.

Always make sure the chuck is tight and the drill bit firmly tightened in the chuck before starting drill.

Wear ear protectors with hammer drilling. Exposure to noise can cause hearing loss.

If provided, use any auxiliary handle(s) supplied with the tool. Loss of control can cause personal injury.

Use thick cushioned gloves and limit exposure time by taking frequent rest periods. Vibration caused by hammer-drill action may be harmful to your hands and arms.

If the bit becomes bound in the workpiece, release the trigger immediately, reverse the direction of rotation and slowly squeeze the trigger to back out the bit. Be ready for a strong reaction torque. The drill body will tend to twist in the opposite direction as the drill bit is rotating.

Do not run the tool while carrying it at your side. A spinning drill bit could become entangled with clothing and injury may result.

Do not use dull or damaged bits and accessories. Dull or damaged bits have a greater tendency to bind in the workpiece.

Ensure the switch is in the OFF position before inserting battery pack. Inserting the battery pack into power tools that have the switch on invites accidents.

BATTERY PACK & CHARGER SAFETY

BATTERY SAFETY INSTRUCTIONS

⚠️ WARNING: Only use the charger supplied with this kit to charge the 20V Li-ion batteries for this tool. Charging any other batteries may damage the charger and possibly cause serious injury.

1. Recharge only with the charger specified by the manufacturer. A charger that is suitable for one type of battery pack may create a risk of fire when used with another battery pack. Incorrect use may result in electric shock, overheating or leakage of corrosive liquid from the battery.
2. Use the tool only with specifically designated battery packs. Use of any other battery packs may create a risk of injury and fire.
3. Be aware of possible hazards when not using your battery tool or when changing accessories. To reduce risk, remove battery packs from the machine while not in operation. This will reduce the risk of electric shock, fire or serious personal injury.
4. Do not place appliances or their batteries near fire or heat. Continuous intense sunlight, fire or other heat sources may cause an increased danger of explosion.

5. Do not crush, drop or damage the battery pack. Do not use a battery pack or charger that has been dropped or received a sharp blow. A damaged battery is subject to explosion. Properly dispose of a dropped or damaged battery immediately.
6. Batteries can explode in the presence of a source of ignition, such as a pilot light. To reduce the risk of serious personal injury, never use any cordless product in the presence of an open flame. An exploded battery can propel debris and chemicals. If exposed, flush with water immediately.
7. Do not charge battery in a damp or wet location. Following this rule will reduce the risk of electric shock.
8. Longer life and better performance can be obtained if the battery pack is charged when the air temperature is between 75°F / 24°C and 64°F / 18°C. Do not charge the battery pack in air temperature below 41°F / 5°C or above 105°F / 40.5°C. This is important as it can prevent serious damage to the battery pack.
9. Under extreme usage or temperature conditions, battery leakage may occur. If liquid comes in contact with your skin, wash immediately with soap and water. If liquid gets into your eyes, flush them with clean water for at least 10 minutes, then seek immediate medical attention.
10. When battery pack is not in use, keep it away from other metal objects like: paper clips, coins, keys, nails, screws, or other small metal objects that can make a connection from one terminal to another. Shorting the battery terminals together may cause sparks, burns, or a fire.
11. Do not disassemble the battery and avoid mechanical damage to the battery. Risk of short circuit and fumes may be emitted. Ensure fresh air and seek medical assistance in the event of discomfort.
12. Always remove battery pack from your tool when you are assembling parts, making adjustments, cleaning, or when not in use. Removing battery pack will prevent accidental starting that could cause serious personal injury.
13. Always remove battery pack before storing the device. When battery becomes fully charged, unplug the charger from the power supply and remove the battery pack from the charger.
14. Keep battery pack dry, clean, and free from oil and grease. Always use a dry cloth when cleaning. Never use brake fluids, gasoline, petroleum-based products, or any solvents to clean battery pack.
15. Keep the battery pack out of the reach of children.

CHARGER SAFETY INSTRUCTIONS

1. The plug of the charger must match the outlet. Never modify the plug in any way. Unmodified plugs and matching outlets will reduce the risk of electric shock.
2. Ensure the battery pack is charged indoors only, in a dry, cool and well ventilated environment.
3. Do not subject the battery to sunlight over long periods and do not leave it near a heat source. Heat damages the battery and there is a risk of explosion.
4. Allow a hot battery to cool before charging.

5. Do not use non-rechargeable batteries!
6. Do not attempt to charge battery packs other than those supplied. The charger and battery pack supplied with it are specifically designed to work together.
7. Before each use, check the charger, cable, and plug. Do not use a defective charger and do not disassemble the charger. Incorrect reassembly may result in the risk of fire, electric shock, or electrocution.
8. Protect the charger against moisture and wet conditions. There is a danger of electric shock.
9. Operate the charger only with the original batteries. Charging other batteries may result in injuries and risk of fire.
10. Avoid mechanical damage to the charger. This can result in internal short circuits.
11. Do not operate the charger on easily inflammable surfaces (e.g. paper, textiles, etc.). The heating of the battery charger during the charging process could pose a fire hazard.
12. Do not abuse the cord of the charger. Never use the cord for carrying, pulling or unplugging the charger.
13. Keep the cord away from heat, oil, sharp edges or moving parts.
14. Damaged or entangled cords increase the risk of electric shock.
15. Do not operate the charger with a damaged cord or plug, which could cause a short circuit and electric shock. If damaged, immediately discontinue use. Replace the charger with the identical unit as listed in the Product Specifications in this manual. If the power cord for this equipment is damaged, it must be replaced by the manufacturer, a customer service agent of the same or qualified person to prevent hazards.
16. Do not use a charger that has been dropped or received a sharp blow.
17. The voltage indicated on the charger rating plate must correspond to the voltage of the power source.
18. Never touch the charger or charger plug with wet hands.
19. The tool battery is not fully charged at the time of delivery. It therefore needs to be fully recharged before you use it for the first time. For the first recharge cycle, charge the battery pack fully.
20. It is good practice to unplug the charger and remove the lithium-ion battery pack when not in use.
21. This charger is not intended for use by persons (including children) with reduced physical, sensory or mental capabilities, or lack of experience and knowledge, unless they have been given supervision or instruction concerning use of the charger by a person responsible for their safety.
22. Children should be supervised to ensure that they do not play with the charger.
23. Never charge batteries near flammable materials, gases, or liquids. Charging near such items can pose a serious risk of fire or explosion. Always charge batteries in a well-ventilated, dry area, away from heat sources, chemicals, or any potential fire hazards.

SERVICE

Have your power tool serviced by a qualified repair person using only identical replacement parts. This will ensure that the safety of the power tool is maintained.

RECYCLING AND DISPOSAL

⚠️ WARNING: Do not dispose of batteries/rechargeable batteries into household waste!

BATTERY PACK RECYCLING



To preserve our natural resources, please recycle or dispose of batteries properly.

The batteries charged by this charger may contain chemicals and metals that are harmful to the environment. Never dispose of rechargeable batteries in your normal household garbage or in landfill sites as they will add to the pollution of the environment.

SAFETY SYMBOLS

⚠️ WARNING: Some of the following symbols may appear on the drill. Study these symbols and learn their meaning. Proper interpretation of these symbols will allow for more efficient and safer operation of this tool.

| | | | |
|-------------------|---------------------------------|----------------|---|
| V | Volts | $3n \sim$ | Three-phase alternating current with neutral |
| A | Amperes | | Read all documentation |
| Hz | Hertz | — — — | Direct current |
| W | Watts | n_0 | No load speed |
| kW | Kilowatts | | Alternating or direct current |
| μF | Microfarads | | Class II Construction |
| L | Litres | | Splash-proof construction |
| kg | Kilograms | | Watertight construction |
| H | Hours | | Protective grounding at terminal, Class I tools |
| N/cm ² | Newtons per square centimetre | .../min | Revolutions or reciprocations per minute |
| Pa | Pascals | \emptyset | Diameter |
| OPM | Oscillation per minute | 0 | Off position |
| Min | Minutes | | Directional Arrow |
| S | Seconds | | Warning symbol |
| \sim or AC | Alternating current | | Wear eye protection |
| $3 \sim$ | Three-phase alternating current | | Wear hearing protection |



c us
JD6360C

This symbol designates that this tool is listed with U.S. and Canadian requirements by cTUVus Testing Laboratories, Inc. UL62841-1, UL62841-2-1; CSA C22.2#62841-1, CSA C22.2#62841-2-1.

KNOW YOUR BENCHMARK 20V MAX BRUSHLESS 2VSR HAMMER DRILL



ASSEMBLY AND OPERATING

CHECKING THE BATTERY CHARGER STATUS

The level of charge remaining in the battery can be checked by using the battery LED power indicator that is contained on the end of the battery.

NOTE: The battery charge remaining may be checked while the battery is installed in the tool with the ON/OFF switch turned OFF. It may also be checked while the battery is removed from the tool. **DO NOT** check the battery charge remaining while the battery is in the charger. You will get a false reading and you may also damage the battery status system.

1. Press and hold the battery status button located on the end of the battery.
2. One or more of the Four LED lights in the LED window will come ON to indicate the amount of charge that is remaining in the battery as follows:

| | | | | | | |
|----------------------------|---------|----------|----------|----------|-----------|---|
| Charge Level Indicator | ○○○○ | ●○○○ | ●●○○ | ●●●○ | ●●●● |  |
| Amount of Charge Remaining | 0 - 10% | 10 - 25% | 25 - 50% | 50 - 75% | 75 - 100% | |

3. Release the battery status button to turn the LEDs OFF.

CHARGING THE BATTERY PACK

1. Place the battery charger (1) in a dry location near a 110–120V 60 Hz
2. Plug the battery charger into the outlet and make sure the green LED indicator light (4) comes ON. If it does not, refer to the chart (Fig. 2) to identify the problem.
3. Turn the battery (2) upside down and slide it onto the charger.

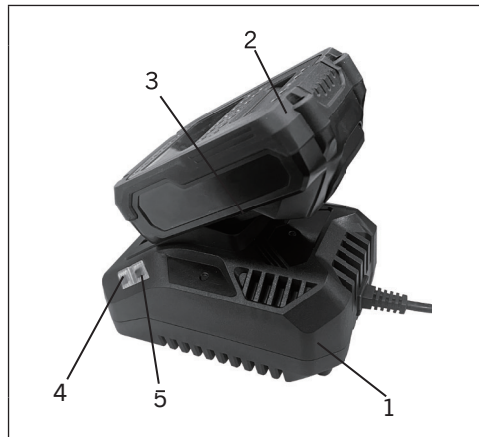

FIG. 1

NOTE: Make sure the grooves (3) in the sides of the battery slide over the matching tabs on the charger (Fig.1) until the battery latch "clicks" into place.

a) When the charger is plugged into the wall receptacle and NO battery is on the charger, the green indicator light (4) will turn ON indicating the charger is "live".

b) When a discharged battery is installed on the charger, the green indicator light will turn OFF and the red indicator light (5) will FLASH. The flashing red indicator light indicates the battery is being charged.

c) If the red indicator light does not come ON, check to make sure battery pack is slid fully onto the charger and the electrical outlet is working properly.

d) See Fig. 2 below for other indicator light functions.

e) A discharged battery pack should be fully charged in up to 75 minutes.

f) It is normal for the battery charger to hum and be warm to the touch during operation.

g) If the battery pack does not charge properly, check to make sure the electrical outlet is "live".

h) Do NOT charge batteries when the work area or the battery temperature is at or below 5°C (41° F) or above 40°C (105° F).





| GREEN LIGHT | RED LIGHT | BATTERY INSERTED INTO CHARGER | SYMBOL | CHARGING STATUS |
|-------------|-----------|-------------------------------|---|--|
| ON | OFF | NO | NONE | CHARGER CONNECTED TO POWER SUPPLY |
| OFF | FLASHING | YES |  | BATTERY BEING CHARGED |
| ON | OFF | YES |  | BATTERY FULLY CHARGED |
| OFF | ON | YES |  | DEFECTIVE-BATTERY IS CHARGED BUT NOT OPERATIONAL ON TOOL |
| ON | ON | YES |  | CHARGING CONDITIONS ARE EITHER TOO HOT OR TOO COLD |

FIG. 2

INSTALLING A BATTERY ON THE HAMMER DRILL

1. Remove the discharged battery (1) from the drill by pressing downward on the battery release button (2) and sliding the battery backward until it is removed from the drill handle (3) (Fig. 3).
2. Slide the fully charged battery onto the matching keys (4) in the drill handle where the discharged battery has been removed.

NOTE: Make sure the slots in the battery are fully engaged with the mounting keys in the drill handle. The battery release button will "click" into place when the battery is fully installed.

⚠ WARNING: Do not immerse the battery pack in water. Sudden cooling could cause a hot battery to explode or leak.

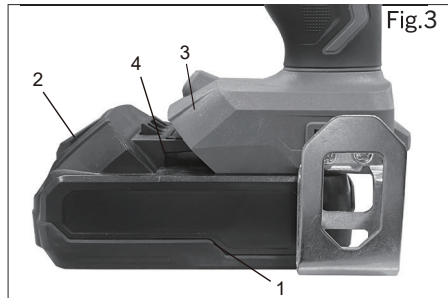

ADJUSTING THE TORQUE AND MODE SELECTOR RING

Your drill is equipped with an adjustable torque adjustment ring (clutch) for driving different types of screws into many materials. It also has settings for “drilling” and “hammer drilling” on the mode selector ring.

The proper setting depends upon the type of material, the size of screw being used, and the function required.

Adjust the torque clutch setting as follows:

1. Identify the torque settings located on the torque adjustment ring (clutch) (1) (Fig. 4).
2. Rotate adjustment ring to align the correct torque setting number with the torque indicator arrow (2).
See below for the correct torque settings.
 - 1–4 For driving small screws.
 - 5–8 For driving medium sized screws into soft materials.
 - 9–14 For driving screws into soft & medium-density materials.
 - 15–18 For driving screws into hardwood, and for driving larger screws.
 - For drilling. This position is marked with a drill bit icon on the mode selector ring (3) (Fig. 4). The drill position overrides the clutch for drilling.
 - To activate hammer mode, turn the mode selector ring to the hammer icon. The torque adjustment ring is not active in this mode, as full torque is applied automatically.

FORWARD/REVERSE SWITCH

The forward/reverse switch (1) is conveniently mounted above the ON/OFF trigger switch (2) (Fig. 5). To make the drill rotate clockwise (for drilling) push the forward/reverse switch to the left. To make the drill rotate counter clockwise for removing screws, push the forward/reverse switch to the right.

NOTES:

- a) Never change the position of the forward/reverse switch while the chuck is turning.
- b) The trigger switch will NOT function with the forward/reverse switch in the middle position.

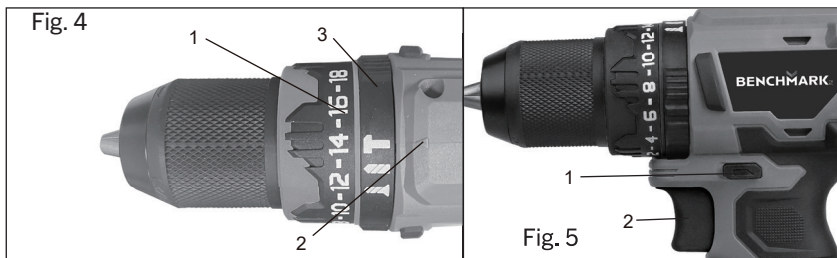

VARIABLE-SPEED TRIGGER SWITCH

This drill is equipped with a variable-speed ON/OFF trigger switch.

1. To start drill, gently squeeze the trigger switch (2) (Fig. 6).

NOTE: The drill will turn at its slowest speed when the trigger switch is depressed slightly. The drill will turn at its fastest speed when the trigger switch is fully depressed.

2. To stop the drill, release the trigger switch.

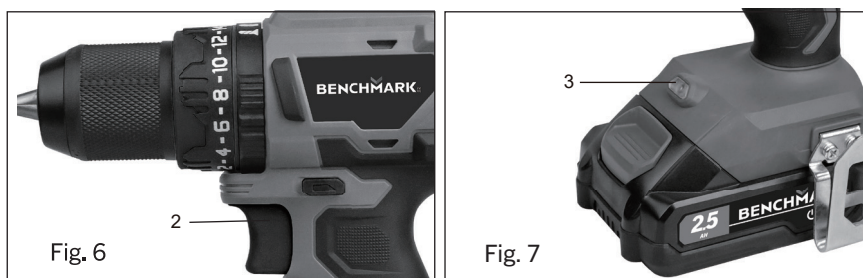

NOTE: Drilling at a slow speed for an extended period of time may cause the drill motor or the battery pack to overheat. If either the drill or the battery gets hot, stop drilling and allow them to cool for at least 15 minutes.

LED WORK LIGHT

The LED work light (3) will automatically turn ON when the trigger switch is squeezed (Fig. 7). It will automatically turn OFF when the trigger switch is released.

NOTE: The LED light has a 20 second time delay.

TWO-SPEED GEAR BOX SWITCH

The two-speed gear box switch is located on the top of the drill housing. Set the speed-control switch to the desired speed before starting the drill. Slide the speed-control switch BACK (Fig. 8a) for low-speed operation. Slide the speed control-switch FORWARD (Fig. 8b) for high-speed operation.

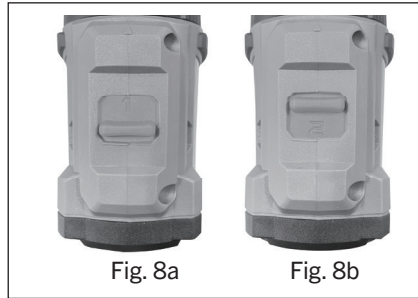

NOTES:

- a) Use low-speed setting for drilling large holes and for driving screws.
- b) Use high-speed setting for drilling smaller holes.
- c) Do NOT change the speed-control switch position while drill is turned ON. Damage to the gears may result.

ELECTRIC BRAKE

This tool is equipped with an electric brake. When the trigger is released it activates the brake to stop the chuck quickly. This feature is especially useful for high-volume tasks that involve repetitive screw driving and removal, allowing users to complete more work in less time with less effort.

INSTALLING DRILL BITS

⚠ WARNING: Never hold the chuck body with one hand and use the drill power to rotate the drill body to loosen or tighten bits. Serious injury may result.

This drill is equipped with a keyless chuck.

1. To open the keyless drill chuck, grasp and hold the chuck (1) with one hand (Fig. 9), and rotate in a counterclockwise direction until the chuck jaws (2) open wide enough to accept the bit (3).
2. Insert the bit into the chuck the full length of the jaws. Raise the front of your drill slightly to prevent the bit from falling out of the chuck jaws.
3. Tighten the chuck jaws onto the bit by turning the chuck body in a clockwise direction.

NOTE: Make sure the bit is properly aligned in the jaws and NOT at an angle. An improperly aligned bit could be thrown from the chuck when drill is started. Make sure flat sides of the screwdriver bit are being grasped by the chuck jaws.

4. Finish tightening the chuck jaws by holding the chuck collar with one hand and firmly tightening the chuck body by rotating it in a clockwise direction.

NOTE: Hand tighten the chuck jaws. Do NOT use pliers. You will damage the chuck.

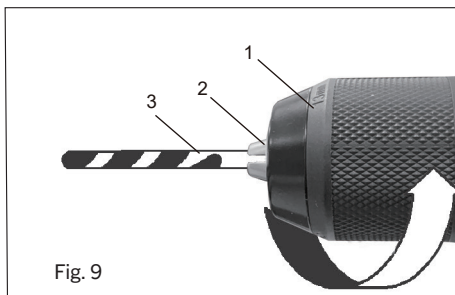

Fig. 9

⚠ WARNING: Do not insert the drill bit into the chuck and tighten as shown in Fig. 10. The drill bit **MUST** be properly inserted with all three of the chuck jaws holding the bit centered in the chuck. Failure to properly insert the drill bit could cause the drill bit to be thrown from the chuck, resulting in possible serious injury or damage to the chuck.

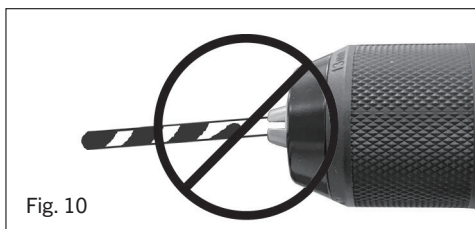

Fig. 10

REMOVING BITS

1. To open the keyless drill chuck, grasp and hold the chuck body and rotate it in a counterclockwise direction until the chuck jaws open wide enough to release the bit.
2. Remove the drill bit.

⚠ WARNING: For safety reasons, the operator must read the sections of this Owner's Manual entitled "GENERAL SAFETY WARNINGS", "POWER TOOL SAFETY", "SPECIFIC SAFETY RULES", "BATTERY & CHARGER SAFETY" and "SYMBOLS" before using this cordless drill.

Verify the following every time the cordless drill is used:

1. Safety glasses, safety goggles, or face shield is being worn.
2. Hearing protection is being worn.
3. The chuck has not worked loose on the spindle.
4. The bit is in good condition and is properly tightened onto the chuck.

Failure to observe these safety rules will significantly increase the risk of injury.

DRILLING

When drilling into smooth, hard surfaces such as metal, use a center punch to mark the desired hole location. This will prevent the drill bit from slipping off center as the hole is started.

The workpiece to be drilled should be secured in a vice or with clamps to keep it from turning as the drill bit rotates (Fig. 11).

1. Check the drill bit to make sure it is firmly locked into the drill chuck and verify that the forward/reverse switch is in the forward position.
2. Set the mode selector ring to the drilling position.
3. Hold the drill firmly with both hands whenever possible. Use one hand to grasp the handle and switch.

NOTE: Make sure the hand placed on the body of the drill does not cover the air vents. Covering these air vents will reduce motor cooling, and possibly lead to overheating the motor.

4. While holding the drill firmly, place the point of the drill bit at the point to be drilled. Squeeze the switch trigger to start the drill.

NOTES: Always use a higher drill speed when drilling small holes. Use a slower drill speed when drilling large holes.

5. Move the drill bit into the workpiece applying only enough pressure to keep the bit cutting. Do not force the drill bit or apply sideways pressure to elongate the hole.

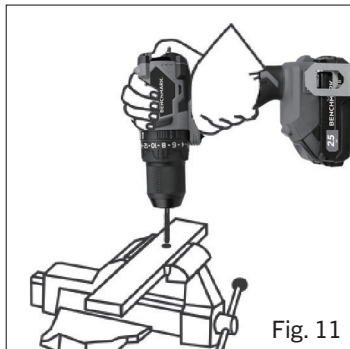

Fig. 11

⚠ WARNING: Be prepared for binding and bit breakthrough. When these situations occur, the drill bit has a tendency to grab the workpiece. This action will kick the drill opposite to the direction of the drill bit rotation and could cause loss of control when breaking through material as you complete drilling the hole. If you are not prepared, this loss of control can result in serious injury.

When drilling metals, use light oil on the drill bit to keep it from overheating. The oil will prolong the life of the drill bit and improve the cutting action. If the bit jams in the workpiece, or if the drill stalls, release the trigger switch immediately. Remove the bit from the workpiece and determine the reason for jamming.

DRIVING SCREWS

When driving screws, care must be taken to use the bit that correctly fits the screw being driven. Make sure you use the largest bit size that will properly fit into the head of the screw.

1. Select the correct screwdriver bit for the screw being driven.
2. Fasten the screwdriver bit into the chuck, making sure the flat sides of the bit are gripped by the chuck jaws.
3. Set the torque clutch to the appropriate setting.

NOTE: If the workpiece material is particularly soft or porous, set the torque clutch to a lower setting to avoid overdriving the screw.

4. If the screw is driven too far into the workpiece before the clutch releases, set the clutch to a lower setting, and do not pull the trigger switch fully back. If the screw is not driven far enough into the workpiece, set the clutch to a higher setting.

NOTE: Do not continue to drive the screw once the clutch has released. This causes unnecessary wear of the clutch.

HAMMER MODE

Use for drilling into tough materials like concrete, brick, and stone.

1. Choose the right bit. Use a masonry bit designed for hammer mode. These bits are made to withstand the impact and pressure of the hammer action.
2. Set the correct speed. Hammer mode works best at a lower speed setting. Start slow to ensure the drill bit penetrates the material before increasing speed.
3. Keep the drill steady. Hold the drill firmly with both hands to maintain control. Let the tool's hammering action do the work — do not force it.
4. Drill with steady pressure. Apply consistent pressure, but avoid pushing too hard. Let the hammering action take care of most of the work to prevent overheating the tool or damaging the bit.
5. Use short bursts. If drilling deep holes, use short bursts of hammering to avoid excessive heat buildup. Allow the tool to cool if needed.

 **WARNING:** Always wear safety goggles, hearing protection, and gloves when using the hammer mode, especially in tougher materials like concrete.

REMOVING THE CHUCK

1. Remove the battery pack from the drill.
2. Insert a 5/16" (8 mm) or larger hex key (1) into the chuck (2) and tighten the chuck jaws securely (Fig. 12). Make sure each of the chuck jaws (3) is seated on the flat surfaces of the hex key.
3. Tap the hex key sharply with a mallet (4) in a CLOCKWISE direction. This action will loosen the screw in the chuck for easy removal.
4. Open chuck jaws and remove the hex key.

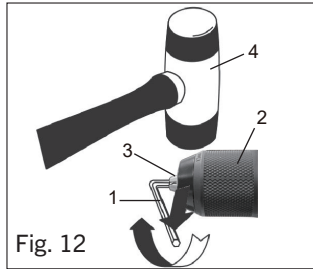

5. Open the chuck jaws as far as possible.
6. Remove the chuck screw using a #2 \oplus screwdriver (Fig. 13).

NOTE: Turn the screw **CLOCKWISE** to remove it. This screw has a left-handed thread.

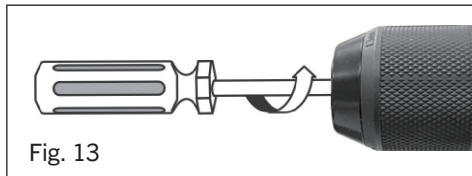

7. Insert the hex key into the chuck and tighten jaws of chuck securely (Fig. 14). Tap the hex key sharply with a mallet in a **COUNTER-CLOCKWISE** direction. This will loosen the chuck on the spindle. The chuck can now be unscrewed and removed from the spindle by hand.

RETIGHTENING A LOOSE CHUCK

1. Remove the battery pack from the drill.
2. Insert a 5/16" (8 mm) or larger hex key (1) into the chuck (2) and tighten the chuck jaws securely (Fig. 15). Make sure each of the chuck jaws (3) is seated on the flat surfaces of the hex key.
3. Tap the hex key sharply with a mallet (4) in a **CLOCKWISE** direction. This action will loosen the screw in the chuck for easy removal.
4. Open the chuck jaws and remove the hex key.
5. Tighten the chuck screw using a #2 \oplus screwdriver (Fig. 13).

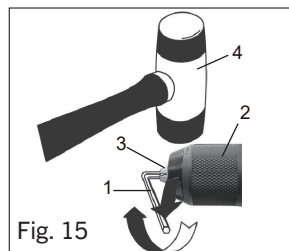
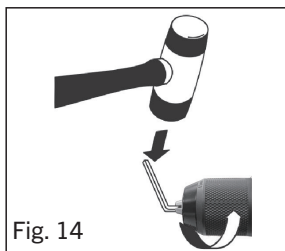

NOTE: Turn the screw **COUNTER-CLOCKWISE** to tighten it. This screw has a left-handed thread.

MAINTENANCE

GENERAL

 **WARNING:** When servicing, use only identical replacement parts. The use of any other part may create a hazard or cause product damage.

DO NOT use solvents when cleaning plastic parts. Plastics are susceptible to damage from various types of commercial solvents and may be damaged by their use. Use a clean cloth to remove dirt, dust, oil, grease, etc.

 **WARNING:** Do not allow brake fluids, gasoline, petroleum-based products, penetrating oils, etc. to come into contact with plastic parts. They contain chemicals that can damage, weaken or destroy plastic.

DO NOT abuse power tools. Abusive practices can damage the tool and the workpiece.

 **WARNING:** DO NOT attempt to modify tools or create accessories. Any such alteration or modification is misuse and could result in a hazardous condition leading to possible serious injury. It will also void the warranty.

LUBRICATION

All of the bearings in this tool are lubricated with a sufficient amount of high-grade lubricant for the life of the unit under normal conditions. Therefore, no further lubrication is required.

BATTERY PACK REMOVAL AND PREPARATION FOR RECYCLING

To preserve our natural resources, please recycle or dispose of batteries properly.

The batteries accompanying this tool may contain chemicals and metals that are harmful to the environment. Never dispose of rechargeable batteries in your normal household garbage or in landfill sites, because they will add to the pollution of the environment.

Consult your local waste authority for information regarding available recycling and disposal options.

 **WARNING:** Upon removal of the battery pack, cover the terminals of the battery pack with electrical tape or heavy-duty tape. Never touch both terminals with metal objects or parts, because a short circuit may result. Keep away from children. Do not attempt to destroy or disassemble battery pack or remove any of its components. Rechargeable batteries must be recycled or disposed of properly.

EXPLODED VIEW

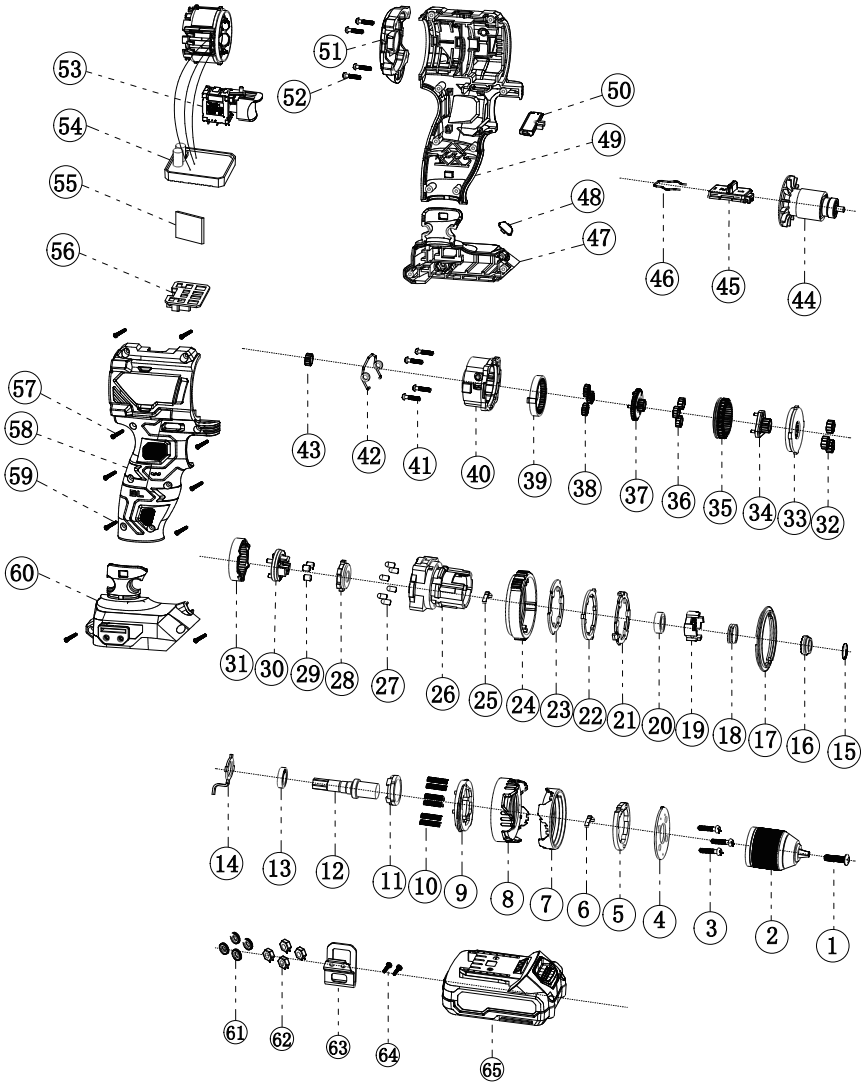

PARTS LIST

⚠ WARNING: When servicing, use only original equipment replacement parts. The use of any other parts may create a safety hazard or cause damage to the drill. Any attempt to repair or replace electrical parts on this drill may create a safety hazard unless repairs are performed by a qualified technician. For more information, call the Toll-free Helpline, at 1-866-349-8665; Monday - Friday: 9am to 5pm EST.

Always order by part number.

| Key # | Part # | Part Name | Quantity |
|-------|------------|-------------------------------------|----------|
| 1 | 4020030020 | Chuck screw M6 x 18 | 1 |
| 2 | 1140030051 | Chuck | 1 |
| 3 | 4030020014 | Tapping screw ST2.9 x 16 | 3 |
| 4 | 2030160174 | Compressing plate | 1 |
| 5 | 3150160301 | Positioning bracket | 1 |
| 6 | 2050070074 | Positioning spring | 1 |
| 7 | 3110010283 | Adjustable decorative plate ring | 1 |
| 8 | 3120080152 | Torque setting ring | 1 |
| 9 | 3150190234 | Inner threaded ring | 1 |
| 10 | 2050060310 | Spring | 6 |
| 11 | 2010240055 | Snap ring | 1 |
| 12 | 2040050220 | Spindle | 1 |
| 13 | 4010010183 | Bearing 6800-2RS | 1 |
| 14 | 2030270020 | Positioner | 1 |
| 15 | 3140020195 | O ring | 1 |
| 16 | 2010100042 | Upper Impact Block | 1 |
| 17 | 3110010284 | Adjustable decorative plate ring | 1 |
| 18 | 2050060309 | Spring | 1 |
| 19 | 2010100043 | Lower Impact Block | 1 |
| 20 | 4010010154 | Bearing 689-Z | 1 |
| 21 | 2030020442 | Adjustable pressure plate | 1 |
| 22 | 2030020441 | Gear pressure plate | 1 |
| 23 | 2030020440 | Washer | 1 |
| 24 | 3120090016 | Impact adjustment sleeve | 1 |
| 25 | 2050070074 | Spring | 1 |
| 26 | 3150070118 | Gear box | 1 |
| 27 | 4110030033 | Needle roller $\Phi 4 \times 7.8$ | 6 |
| 28 | 2010240054 | Lock ring | 1 |
| 29 | 4110070004 | Needle roller $\Phi 4.4 \times 5.5$ | 3 |

| Key # | Part # | Part Name | Quantity |
|-------|------------|-----------------------------|----------|
| 30 | 1170070105 | Planetary carrier | 1 |
| 31 | 2040090098 | Gearing ring | 1 |
| 32 | 2010010159 | Planetary gear | 3 |
| 33 | 2010240053 | Gear ring | 1 |
| 34 | 1170070104 | Planetary carrier | 1 |
| 35 | 2010090096 | Moving gear ring | 1 |
| 36 | 2010010158 | Planetary gear | 1 |
| 37 | 1170070103 | Planetary carrier | 1 |
| 38 | 2010010157 | Planetary gear | 3 |
| 39 | 2010090097 | Fixed ring gear | 1 |
| 40 | 3150080028 | Transmission | 1 |
| 41 | 4030010031 | Screw ST2.9 x 14 | 4 |
| 42 | 2050080235 | High and low speed hooks | 1 |
| 43 | 2010180066 | Motor Gear | 1 |
| 44 | 1030300034 | Brushless motor | 1 |
| 45 | 3120120162 | Speed selector button | 1 |
| 46 | 2050080234 | Speed regulating steel wire | 1 |
| 47 | 3150130198 | Chassis foot plate | 1 |
| 48 | 3160060115 | LED cover | 1 |
| 49 | 3010010214 | Housing | 1 |
| 50 | 3120030153 | FWD/REV lever | 1 |
| 51 | 3160010089 | Housing back cover | 1 |
| 52 | 4030010031 | Screw ST2.9 x 14 | 4 |
| 53 | 1062010044 | Switch assembly | 1 |
| 54 | 1130030129 | Control board | 1 |
| 55 | 3190020096 | Sponge strips | 1 |
| 56 | 3150170020 | Contact plate | 2 |
| 57 | 4030010034 | Screw ST2.9 x 16 | 1 |
| 58 | 3010010214 | Housing | 1 |
| 59 | 4030010031 | Screw ST2.9 x 14 | 9 |
| 60 | 3150130198 | Chassis foot plate | 1 |
| 61 | 4040080005 | Washer | 2 |
| 62 | 4060010044 | Nut | 2 |
| 63 | 2030010074 | Belt clip | 1 |
| 64 | 4020010147 | Screw M4 x 12 | 2 |
| 65 | 1290090054 | Battery | 1 |

WARRANTY

BENCHMARK WARRANTY FOR 20V 2VSR MAX DRILL

If this Benchmark tool fails due to a defect in material or workmanship within five years from the date of purchase, return it to any Home Hardware store with the original bill of sale for exchange. Three year warranty for the battery and charger. This warranty does not include expendable parts including but not limited to blades, brushes, belts, light bulbs.

This warranty covers defects in material or workmanship only. It does not cover normal wear and tear, failure due to abuse/misuse, or defects caused by careless or accidental mishandling. If this Benchmark product is used for commercial or rental purposes, this warranty does not apply.

20V MAX[†] BRUSHLESS 1/2" HAMMER DRILL



5 Year Limited Warranty

3 Year Limited Warranty on Battery and Charger

BENCHMARKTM
MC

BENCHMARK TOOLS CANADA

ST. JACOBS, ONTARIO N0B 2N0

© 2025 Home Hardware Stores Limited

CUSTOMER SERVICE/TECH SUPPORT

1-866-349-8665

1239-219

Made in China



* This BenchmarkTM product carries a five (5) year LIMITED warranty against defects in workmanship and materials. The charger and batteries carry a three (3) year LIMITED warranty. See Owner's Manual for full details.



c us
JD6360C

**READ ALL INSTRUCTIONS BEFORE FIRST USE.
KEEP THIS MANUAL FOR FUTURE REFERENCE.
KEEP AWAY FROM CHILDREN.**

[†] Maximum initial battery voltage (measured without a load) is 20 volts. Normal voltage is 18 volts.



**WEAR CSA APPROVED
EYE PROTECTION**



**WEAR EAR
PROTECTION**



**WEAR A
FACE MASK**