

BENCHMARKTM MC

20V MAX BRUSHLESS 1/2" DRILL



5 Year Limited Warranty
3 Year Limited Warranty on Battery and Charger



Intertek
3042597
JD628620

**READ ALL INSTRUCTIONS BEFORE FIRST USE.
KEEP THIS MANUAL FOR FUTURE REFERENCE.
KEEP AWAY FROM CHILDREN.**

Maximum initial battery voltage (measured without a load)
is 20 volts. Nominal voltage is 18 volts.



**WEAR CSA APPROVED
EYE PROTECTION**



**WEAR EAR
PROTECTION**



**WEAR A
FACE MASK**

PRODUCT SPECIFICATIONS

20V MAX BRUSHLESS 1/2" DRILL	
Variable Chuck Speed	0–600 RPM / 0–2,000 RPM (no load)
Torque Clutch Positions	21
Keyless Chuck	1/2" keyless metal
Max Torque	450 in/lbs.
Max Drilling Capacity In Wood	1" (25mm)
Max Drilling Capacity In Metal	1/2" (13mm)
Weight	3.6lbs. (1.65kg)
Battery	20V 2.5Ah Li-ion (Maximum charged battery voltage, measured without load, is 20V with a nominal value of 18V)
Replacement Battery	5350-023 (2.5Ah) Charge time – up to 75 mins.)
Replacement Charger Assembly	5350-010 (2.4A)

NEED ASSISTANCE?

Call us on our toll-free customer support line:

1-866-349-8665 (Monday through Friday 9am – 5pm Eastern Standard Time)

- Technical questions
- Replacement parts
- Parts missing from package





TABLE OF CONTENTS

Product Specifications	1
Table of Contents	2
General Safety Instructions	3
Eye, Ear & Lung Protection	3
Electrical Safety	4
Power Tool Safety	4
Work Area Safety	4
Electrical Safety	4
Personal Safety	5
Power Tool Use and Care	5
Battery Tool Use and Care	6
Service	6
Specific Safety Rules	6
Battery & Charger Safety	7
Battery Pack Recycling	8
Symbols	9
Know Your Cordless 20V Max Brushless 2VSR Drill	10
Assembly and Operation	11
Checking the Battery Charge Status	11
Checking the Battery Pack	11
Installing a Battery on the Drill	12
Adjusting the Torque	13
Forward/Reverse Switch.....	14
Variable-Speed Trigger Switch.....	14
LED Work Light	15
Two-Speed Gear Box Switch	15
Installing Drill Bits	16
Removing Bits	17
Drilling	17
Driving Screws	18
Removing the Chuck	18
Retightening a Loose Chuck	19
Maintenance	20
General	20
Lubrication	20
Battery Pack Removal and Preparation for Recycling	21
Parts List	21
Exploded View	22
Warranty	23

GENERAL SAFETY INSTRUCTIONS

⚠️ WARNING: Before using this tool or any of its accessories, read this manual and follow all Safety Rules and Operating Instructions. The important precautions, safeguards and instructions appearing in this manual are not meant to cover all possible situations. It must be understood that common sense and caution are factors which cannot be built into the product.

EYE, EAR & LUNG PROTECTION

SYMBOL	MEANING
<p>⚠️ DANGER</p> 	<p>ALWAYS WEAR EYE PROTECTION THAT CONFORMS WITH CSA Z94.3 or ANSI SAFETY STANDARD Z87.1</p> <p>FLYING DEBRIS can cause permanent eye damage. Prescription eyeglasses ARE NOT a replacement for proper eye protection. The usage of a safety standard compliant face shield placed over proper safety glasses or goggles can reduce the risk of facial injury. Non-compliant eyewear can cause serious injury if broken during the operation of a power tool.</p>
<p>⚠️ WARNING</p> 	<p>Use hearing protection, particularly during extended periods of operation of the tool, or if the operation is noisy.</p>
<p>⚠️ WARNING</p> 	<p>WEAR A DUST MASK THAT IS DESIGNED TO BE USED WHEN OPERATING A POWER TOOL IN A DUSTY ENVIRONMENT.</p> <p>Dust that is created by power sanding, sawing, grinding, drilling, and other construction activities may contain chemicals that are known to cause cancer, birth defects, or other genetic abnormalities. These chemicals include:</p> <ul style="list-style-type: none"> • Lead from lead-based paints • Crystalline silica from bricks, cement, and other masonry products • Arsenic and chromium from chemically treated lumber <p>The level of risk from exposure to these chemicals varies, according to how often this type of work is performed. In order to reduce exposure to these chemicals, work in a well-ventilated area, and use approved safety equipment, such as a dust mask that is specifically designed to filter out microscopic particles.</p>
<p>⚠️ WARNING</p> 	<p>TO AVOID ELECTRICAL HAZARDS, FIRE HAZARDS OR DAMAGE TO THE TOOL, USE PROPER CIRCUIT PROTECTION.</p> <p>This tool is wired at the factory for 120 V AC operation. It must be connected to a 120 V AC, 15 A circuit that is protected by a time-delayed fuse or circuit breaker. To avoid shock or fire, replace power cord immediately if it is worn, cut or damaged in any way.</p>

⚠ WARNING

WARNING: Ventilation openings in batteries and chargers must always be open to allow cooling air to circulate freely. Air vents that are blocked, restricted or covered may result in the battery or charger overheating. Overheating may lead to damage to the tool or cause a fire, resulting in possible serious injury.

POWER TOOL SAFETY

⚠ WARNING: Read all safety warnings and instructions. Failure to follow the warnings and instructions may result in electric shock, fire and/or serious injury.

Save all warnings and instructions for future reference.

WORK AREA SAFETY

Keep work area clean and well lit. Cluttered or dark areas invite accidents.

Do not operate power tools in explosive atmospheres, such as in the presence of flammable liquids, gases or dust. Power tools create sparks which may ignite the dust or fumes.

Keep children and bystanders away while operating a power tool. Distractions can cause you to lose control.

ELECTRICAL SAFETY

Power tool plugs must match the outlet. Never modify the plug in any way.

Do not use any adapter plugs with earthed (grounded) power tools. Unmodified plugs and matching outlets will reduce risk of electric shock.

Avoid body contact with earthed or grounded surfaces such as pipes, radiators, ranges and refrigerators. There is an increased risk of electric shock if your body is earthed or grounded.

Do not expose power tools to rain or wet conditions. Water entering a power tool will increase the risk of electric shock.

Do not abuse the cord. Never use the cord for carrying, pulling or unplugging the power tool. Keep cord away from heat, oil, sharp edges or moving parts. Damaged or entangled cords increase the risk of electric shock.

When operating a power tool outdoors, use an extension cord suitable for outdoor use. Use of a cord suitable for outdoor use reduces the risk of electric shock.

If operating a power tool in a damp location is unavoidable, use a residual current device (RCD) protected supply. Use of a ground fault circuit interrupter (GFCI) reduces the risk of electric shock.

PERSONAL SAFETY

Stay alert, watch what you are doing and use common sense when operating a power tool. Do not use a power tool while you are tired or under the influence of drugs, alcohol or medication. A moment of inattention while operating power

tools may result in serious personal injury.

Use personal protective equipment. Always wear eye protection. Protective equipment such as dust mask, non-skid safety shoes, hard hat, or hearing protection used for appropriate conditions will reduce personal injuries.

Prevent unintentional starting. Ensure the switch is in the off-position before connecting to power source and/or battery pack, picking up or carrying the tool. Carrying power tools with your finger on the switch or energizing power tools that have the switch on invites accidents.

Remove any adjusting key or wrench before turning the power tool on. A wrench or a key left attached to a rotating part of the power tool may result in personal injury.

Do not overreach. Keep proper footing and balance at all times. This enables better control of the power tool in unexpected situations.

Dress properly. Do not wear loose clothing or jewellery. Keep your hair, clothing and gloves away from moving parts. Loose clothes, jewellery or long hair can be caught in moving parts.

If devices are provided for the connection of dust extraction and collection facilities, ensure these are connected and properly used. Use of dust collection can reduce dust-related hazards.

POWER TOOL USE AND CARE

Do not force the power tool. Use the correct power tool for your application. The correct power tool will do the job better and safer at the rate for which it was designed.

Do not use the power tool if the switch does not turn it on and off. Any power tool that cannot be controlled with the switch is dangerous and must be repaired.

Disconnect the plug from the power source and/or the battery pack from the power tool before making any adjustments, changing accessories, or storing power tools. Such preventive safety measures reduce the risk of starting the power tool accidentally.

Store idle power tools out of the reach of children and do not allow persons unfamiliar with the power tool or these instructions to operate the power tool. Power tools are dangerous in the hands of untrained users.

Maintain power tools. Check for misalignment or binding of moving parts, breakage of parts and any other condition that may affect the power tool's operation. If damaged, have the power tool repaired before use. Many accidents are caused by poorly maintained power tools.

Keep cutting tools sharp and clean. Properly maintained cutting tools with sharp cutting edges are less likely to bind and are easier to control.

Use the power tool, accessories and tool bits etc. in accordance with these instructions, taking into account the working conditions and the work to be performed. Use of the power tool for operations different from those intended could result in a hazardous situation.

Hold power tool by insulated gripping surfaces when performing an operation where the cutting tool may contact hidden wiring or its own cord. Contact with a

“live” wire will make exposed metal parts of the tool “live” and shock the operator.

Hold power tool by insulated gripping surfaces, when performing an operation where the fastener may contact hidden wiring or its own cord.

Fasteners contacting a “live” wire may make exposed metal parts of the power tool “live” and could give the operator an electric shock.

BATTERY TOOL USE AND CARE

Recharge only with the charger specified by the manufacturer. A charger that is suitable for one type of battery pack may create a risk of fire when used with another battery pack.

Use power tools only with specifically designated battery packs. Use of any other battery packs may create a risk of injury and fire.

When battery pack is not in use, keep it away from metal objects like paper clips, coins, keys, nails, screws, or other small metal objects that can make a connection from one terminal to another. Shorting the battery terminals together may cause burns or fire.

Under abusive conditions, liquids may be ejected from the battery; avoid contact. If contact accidentally occurs, flush with water. If liquid contacts eyes, additionally seek medical help. Liquid ejected from the battery may cause irritation or burns.

SERVICE

Have your power tool serviced by a qualified repair person using only identical replacement parts. This will ensure that the safety of the power tool is maintained.

SPECIFIC SAFETY RULES

 **WARNING: Know your cordless drill. Do not plug in the charger or install the battery in the tool until you have read and understand this Instruction Manual. Learn the tool's applications and limitations, as well as the specific potential hazards related to this tool.** Following this rule will reduce the risk of electric shock, fire, or serious injury.



Always wear eye protection. Any power tool can throw foreign objects into your eyes and cause permanent eye damage. ALWAYS wear safety goggles (not glasses) that comply with ANSI safety standard Z87.1. Everyday glasses have only impact resistant lenses. They ARE NOT safety glasses.

 **WARNING: Glasses or goggles not in compliance with ANSI Z87.1 could cause serious injury when they break.**

 **WARNING: Always use a safety shield, hearing protection and dust mask when drilling concrete.**

 **WARNING: To avoid fire or toxic reaction, never use gasoline, naphtha, acetone, lacquer thinner or similar highly volatile solvents to clean the tool.**

 **WARNING: Use only accessories that are recommended for this cordless drill. Follow the instructions that accompany the accessories. The use of improper accessories may result in injury to the operator or damage to the tool.**

⚠️ WARNING: If any part is missing or damaged, do not plug the tool into the power source or install any accessory until the missing or damaged part is replaced.

Do not drill material too small to be securely held.

Always keep hands out of the path of the drill bit. Avoid awkward hand positions where a sudden slip could cause your hand to move into the path of the drill bit.

Secure the workpiece. Use clamps or a vice to hold the workpiece. It is safer than using your hand and it frees both hands to operate the tool.

Make sure there are no nails or foreign objects in the part of the workpiece to be drilled.

To avoid injury from accidental starting, always remove the battery from the tool before installing or removing a drill bit.

Do not install or use any drill bit that exceeds 7" (17.5 cm) in length or extends more than 6" (15 cm) beyond the chuck jaws. They can bend or break suddenly.

Before starting the operation, jog the drill switch to make sure the drill bit does not wobble or vibrate.

Do not use fly cutters or multiple-part hole cutters, because they can come apart or become unbalanced during use.

Make sure the spindle has come to a complete stop before touching the chuck or attempting to change the drill bit.

Always make sure the chuck is tight and the drill bit firmly tightened in the chuck before starting drill.

BATTERY & CHARGER SAFETY

⚠️ WARNING: Only use the charger supplied with this kit to charge the 20V Li-ion batteries for this tool. Charging any other batteries may damage the charger and possibly cause serious injury.

Do not store or carry the battery in a manner in which metal objects could contact the exposed metal end. Do not place the battery in aprons, pockets, drawers, etc. with loose nails, screws, keys etc. The battery could short circuit causing a fire, personal injury, or damage to the battery.

Never attempt to open the battery for any reason. If the housing of the battery breaks or cracks, immediately discontinue use and do not recharge.

Do not charge the battery if it is wet or shows any evidence of corrosion.

A small leakage from the battery may occur under extreme usage, charging or temperature conditions. This does not indicate a failure. However, if the outer seal is broken and this leakage gets on your skin, follow these steps:

1. Wash immediately with soap and water.
2. Neutralize with a mild acid such as lemon juice or vinegar.
3. If liquid gets into your eyes, flush immediately with clean water for a minimum of 10 minutes and seek medical attention.

NOTE: The battery liquid is slightly acidic.

Do not incinerate the battery. It can explode in a fire.

Do not use an extension cord. Plug the charger cord directly into an electrical outlet.

Use the charger only in a standard 120V, 60 Hz electrical outlet.

Do not use the charger in wet or damp conditions. It is intended for indoor use only. Do not use the charger near sinks or tubs. Do not immerse the charger in water. Do not allow the cord to hang over the edge of a table or counter or touch hot surfaces.

The charger should be placed away from sinks and hot surfaces.

Do not use the charger to charge any batteries other than the cordless drill batteries. Other batteries may explode.

Do not allow the cord to hang over the edge of a table or counter or touch hot surfaces. The charger should be placed away from sinks and hot surfaces.

Do not operate charger if the cord or plug is damaged. Replace the damaged cord and plug immediately.

Do not operate the charger if it has received a sharp blow, been dropped or otherwise damaged in any way. Have a qualified technician examine the charger and repair it if necessary. Do not disassemble the charger.

Do NOT charge the batteries when the work area or the battery temperature is at or below 5° C (41° F) or above 40.5° C (105° F).

Unplug the charger when not in use and before cleaning or maintenance.

BATTERY PACK RECYCLING











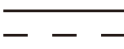



To preserve our natural resources, please recycle or dispose of batteries properly.

The batteries charged by this charger may contain chemicals and metals that are harmful to the environment. Never dispose of re-chargeable batteries in your normal household garbage or in landfill sites as they will add to the pollution of the environment.

SYMBOLS

⚠️ WARNING: Some of the following symbols may appear on the drill. Study these symbols and learn their meaning. Proper interpretation of these symbols will allow for more efficient and safer operation of this tool.

V	VOLTS		Three-phase alternating current with neutral
A	Amperes		Direct current
Hz	Hertz	n_0	No load speed
W	Watts		Alternating or direct current
kW	Kilowatts		Class II construction
μF	Microfarads		Splash-proof construction
L	Liters		Watertight construction
kg	Kilograms		Protective grounding at grounding terminal, Class I tools
H	Hours	.../min	Revolutions or reciprocations per minute
N/cm²	Newtons per square centimeter	∅	Diameter
Pa	Pascals	0	Off position
OPM	Oscillations per minute		Arrow
MIN	Minutes		Warning symbol
S	Seconds		Wear your safety glasses
 or ac.	Alternating current		Wear a dust mask
 3	Three-phase alternating current		Wear hearing protection



This symbol designates that this tool is listed with Canadian and U.S. requirements by ETL Testing Laboratories, Inc. Conforms to UL Std. UL 60745-1 and 60745-2-1 60745-2-2. Certified to CAN/CSA Std. C22.2 No. 60745-1 and 60745-2-1 60745-2-2.

KNOW YOUR CORDLESS 20V MAX BRUSHLESS 2VSR DRILL

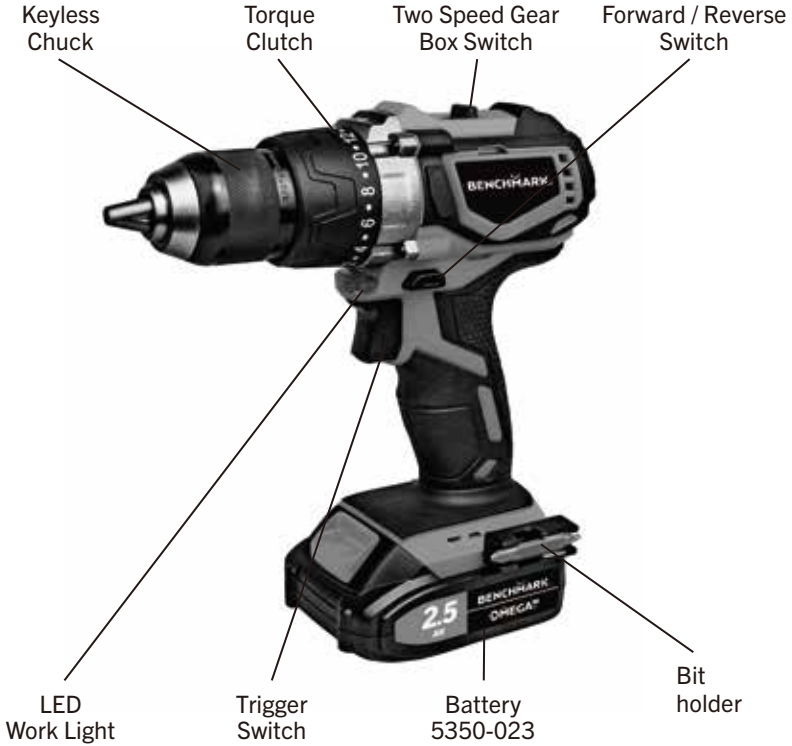

Battery charger 5350-010



ASSEMBLY AND OPERATION

CHECKING THE BATTERY CHARGE STATUS

The level of charge remaining in the battery can be checked by using the battery LED power indicator that is contained on the end of the battery.

NOTE: The battery charge remaining may be checked while the battery is installed in the tool with the ON/OFF switch turned OFF. It may also be checked while the battery is removed from the tool. **DO NOT** check the battery charge remaining while the battery is in the charger. You will get a false reading and you may also damage the battery status system.

1. Press and hold the battery status button located on the end of the battery.
2. One or more of the Four LED lights in the LED window will come ON to indicate the amount of charge that is remaining in the battery as follows:

Charge Level Indicator						
Amount of Charge Remaining	0 - 10%	10 - 25%	25 - 50%	50 - 75%	75 - 100%	

3. Release the battery status button to turn the LEDs OFF.

CHECKING THE BATTERY PACK

1. Place the battery charger (1) in a dry location near a 110–120V 60 Hz electrical outlet (Fig. 1).
2. Plug the battery charger into the outlet and make sure the green LED indicator light (5) comes ON. If it does not, refer to the chart (Fig. 2) to identify the problem.
3. Turn the battery (2) upside down and slide it onto the charger.

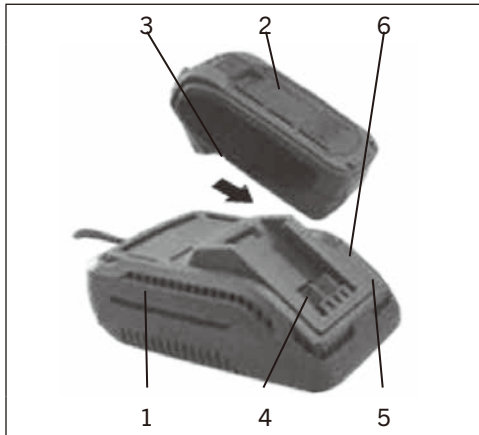

FIG. 1

- NOTE:** a) When the charger is plugged into the wall receptacle and NO battery is on the charger, the green indicator light (5) will turn ON indicating the charger is “live”.
- b) When a discharged battery is installed on the charger, the green indicator light will turn OFF and the red indicator light (6) will FLASH. The flashing red indicator light indicates the battery is being charged.
- c) If the red indicator light does not come ON, check to make sure battery pack is slid fully onto the charger and the electrical outlet is working properly.
- d) See Fig. 2 at right for other indicator light functions.
- e) A discharged battery pack should be fully charged in up to 75 minutes.
- f) It is normal for the battery charger to hum and be warm to the touch during operation.
- g) If the battery pack does not charge properly, check to make sure the electrical outlet is “live”.
- h) Do NOT charge batteries when the work area or the battery temperature is at or below 5°C (41° F) or above 40°C (105° F).

Green Light	Red Light	Battery Inserted Into Charger	Charging Status
ON	OFF	ON	Charger connected to power supply
OFF	Flashing	YES	Battery being charged
ON	OFF	YES	Battery fully charged
OFF	ON	YES	Battery defective or bad contact
ON	ON	YES	Battery too hot or too cold to be charged

FIG. 2

INSTALLING A BATTERY ON THE DRILL

1. Remove the discharged battery (1) from the drill by pressing downward on the battery release button (2) and sliding the battery backward until it is removed from the drill handle (3) (Fig. 3).
2. Slide the fully charged battery onto the matching keys (4) in the drill handle where the discharged battery has been removed.

NOTE: Make sure the slots in the battery are fully engaged with the mounting keys in the drill handle. The battery release button will “click” into place when the battery is fully installed.

⚠ WARNING: Do not immerse the battery pack in water. Sudden cooling could cause a hot battery to explode or leak.

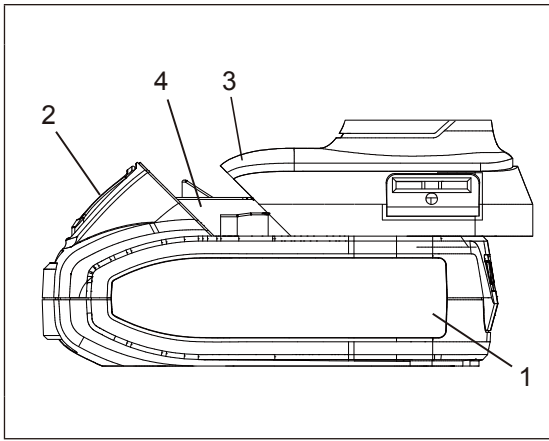

FIG. 3

ADJUSTING THE TORQUE

Your drill is equipped with an adjustable torque clutch for driving different types of screws into different types of materials. It also has a setting for “drilling”.

The proper setting depends upon the type of material, the size of screw being used, and the function required.

Adjust the torque setting as follows:

1. Identify the torque settings located on the torque adjustment ring (1) (Fig. 4).
 2. Rotate adjustment ring to align the correct torque setting number with the torque indicator arrow (2). See the chart below for the correct torque settings.
- 1–4 For driving small screws.
 - 5–7 For driving medium sized screws into soft materials.
 - 8–10 For driving screws into soft & medium-density materials.
 - 11–13 For driving screws into hardwood.
 - 14–20 For driving large screws.
 - For drilling. This position is marked with a drill bit icon (3) on the torque adjustment ring (Fig. 5).

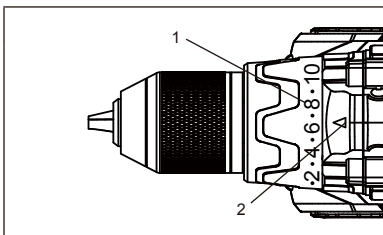

FIG. 4

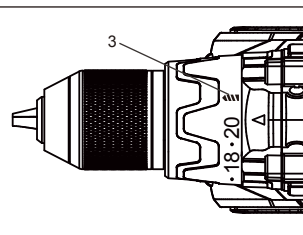
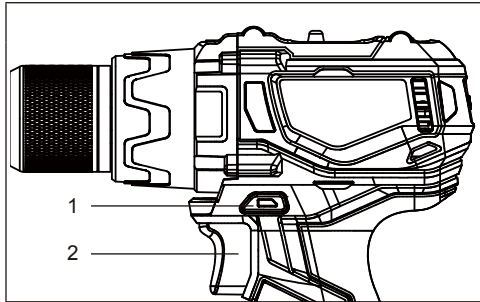

FIG. 5

FORWARD/REVERSE SWITCH

The forward/reverse switch (1) is conveniently mounted above the trigger switch (2) (Fig. 6). To make the drill rotate clockwise (for drilling) push the forward/reverse switch to the left. To make the drill rotate counter clockwise for removing screws, push the forward/reverse switch to the right.

NOTE: a) Never change the position of the forward/reverse switch while the chuck is turning. b) The trigger switch will NOT function with the forward/reverse switch in the middle position.

**FIG. 6****VARIABLE-SPEED TRIGGER SWITCH**

This drill is equipped with a variable-speed ON/OFF trigger switch.

1. To start drill, gently squeeze the trigger switch (2) (Fig. 7).

NOTE: The drill will turn at its slowest speed when the trigger switch is depressed slightly. The drill will turn at its fastest speed when the trigger switch is fully depressed.

2. To stop the drill, release the trigger switch.

NOTE: Drilling at a slow speed for an extended period of time may cause the drill motor or the battery pack to overheat. If either the drill or the battery gets hot, stop drilling and allow them to cool for at least 15 minutes.

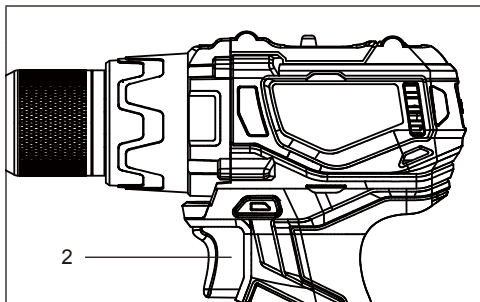
**FIG. 7**

LED WORK LIGHT

The LED work light (3) will automatically turn ON when the trigger switch is squeezed (Fig. 8). It will automatically turn OFF when the trigger switch is released.

NOTE: The LED light has a 20-second time delay.

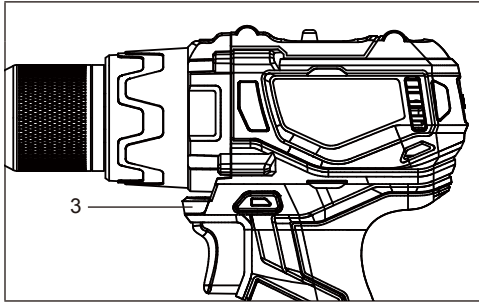

FIG. 8

TWO-SPEED GEAR BOX SWITCH

The two-speed gear box switch is located on the top of the drill housing. Set the speed-control switch to the desired speed before starting the drill. Slide the speed-control switch FORWARD.

(Fig. 9a) for low-speed operation. Slide the speed control-switch BACK (Fig. 9b) for high-speed operation.

NOTE: a) Use low-speed setting for drilling large holes and for driving screws.

b) Use high-speed setting for drilling smaller holes.

c) Do NOT change the speed-control switch position while drill is turned ON. Damag to the gears may result.

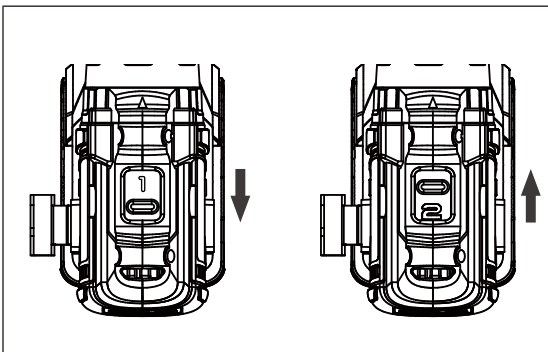

FIG. 9A

FIG. 9B

INSTALLING DRILL BITS

⚠️ WARNING: Never hold the chuck body with one hand and use the drill power to rotate the drill body to loosen or tighten bits. Serious injury may result.

This drill is equipped with a keyless chuck.

1. To open the keyless drill chuck, grasp and hold the chuck (1) with one hand (Fig. 10), and rotate in a counterclockwise direction until the chuck jaws (2) open wide enough to accept the bit (3).
2. Insert the bit into the chuck the full length of the jaws. Raise the front of your drill slightly to prevent the bit from falling out of the chuck jaws.
3. Tighten the chuck jaws onto the bit by turning the chuck body in a clockwise direction.

NOTE: Make sure the bit is properly aligned in the jaws and NOT at an angle. An improperly aligned bit could be thrown from the chuck when drill is started. Make sure flat sides of the screwdriver bit are being grasped by the chuck jaws.

4. Finish tightening the chuck jaws by holding the chuck collar with one hand and firmly tightening the chuck body by rotating it in a clockwise direction.

NOTE: Hand tighten the chuck jaws. Do NOT use pliers. You will damage the chuck.

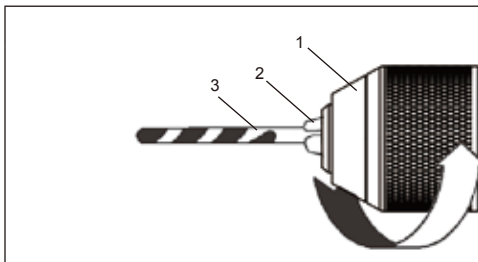

FIG. 10

⚠️ WARNING: Do not insert the drill bit into the chuck and tighten as shown in Fig. 11. The drill bit **MUST** be properly inserted with all three of the chuck jaws holding the bit centred in the chuck. Failure to properly insert the drill bit could cause the drill bit to be thrown from the chuck, resulting in possible serious injury or damage to the chuck.

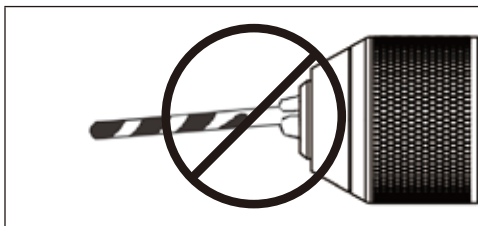

FIG. 11

REMOVING BITS

1. To open the keyless drill chuck, grasp and hold the chuck body and rotate it in a counterclockwise direction until the chuck jaws open wide enough to release the bit.
2. Remove the drill bit.

⚠ WARNING: For safety reasons, the operator must read the sections of this Owner's Manual entitled "GENERAL SAFETY WARNINGS", "POWER TOOL SAFETY", "SPECIFIC SAFETY RULES", "BATTERY & CHARGER SAFETY" and "SYMBOLS" before using this cordless drill.

Verify the following every time the cordless drill is used:

1. Safety glasses, safety goggles, or face shield is being worn.
2. Hearing protection is being worn.
3. The chuck has not worked loose on the spindle.
4. The bit is in good condition and is properly tightened onto the chuck.

Failure to observe these safety rules will significantly increase the risk of injury.

DRILLING

When drilling into smooth, hard surfaces such as metal, use a centre punch to mark the desired hole location. This will prevent the drill bit from slipping off centre as the hole is started.

The workpiece to be drilled should be secured in a vice or with clamps to keep it from turning as the drill bit rotates (Fig. 12).

1. Check the drill bit to make sure it is firmly locked into the drill chuck and verify that the forward/reverse switch is in the forward position.
2. Set the torque clutch to the drilling position.
3. Hold the drill firmly with both hands whenever possible. Use one hand to grasp the handle and switch.

NOTE: Make sure the hand placed on the body of the drill does not cover the air vents. Covering these air vents will reduce motor cooling, and possibly lead to overheating the motor.

4. While holding the drill firmly, place the point of the drill bit at the point to be drilled. Squeeze the switch trigger to start the drill.

NOTES: Always use a higher drill speed when drilling small holes. Use a slower drill speed when drilling large holes.

5. Move the drill bit into the workpiece applying only enough pressure to keep the bit cutting. Do not force the drill bit or apply sideways pressure to elongate the hole.

⚠ WARNING: Be prepared for binding and bit breakthrough. When these situations occur, the drill bit has a tendency to grab the workpiece. This action will kick the drill opposite to the direction of the drill bit rotation and could cause loss of control when breaking through material as you complete drilling the hole. If you are not prepared, this loss of control can result in serious injury.

When drilling metals, use light oil on the drill bit to keep it from overheating. The oil will prolong the life of the drill bit and improve the cutting action. If the bit jams in the workpiece, or if the drill stalls, release the trigger switch immediately. Remove the bit from the workpiece and determine the reason for jamming.

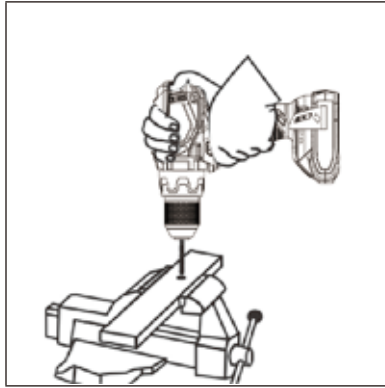

FIG. 12

DRIVING SCREWS

When driving screws, care must be taken to use the bit that correctly fits the screw being driven. Make sure you use the largest bit size that will properly fit into the head of the screw.

1. Select the correct screwdriver bit for the screw being driven.
2. Fasten the screwdriver bit into the chuck, making sure the flat sides of the bit are gripped by the chuck jaws.
3. Set the torque clutch to the appropriate setting, based on the chart on Page 12.

NOTE: If the workpiece material is particularly soft or porous, set the torque clutch to a lower setting to avoid overdriving the screw.

4. If the screw is driven too far into the workpiece before the clutch releases, set the clutch to a lower setting, and do not pull the trigger switch fully back. If the screw is not driven far enough into the workpiece, set the clutch to a higher setting.

NOTE: Do not continue to drive the screw once the clutch has released. This causes unnecessary wear of the clutch.

REMOVING THE CHUCK

1. Remove the battery pack from the drill.
2. Insert a 5/16" (8 mm) or larger hex key (1) into the chuck (2) and tighten the chuck jaws securely (Fig. 13). Make sure each of the chuck jaws (3) is seated on the flat surfaces of the hex key.
3. Tap the hex key sharply with a mallet (4) in a CLOCKWISE direction. This action will loosen the screw in the chuck for easy removal.
4. Open chuck jaws and remove the hex key.

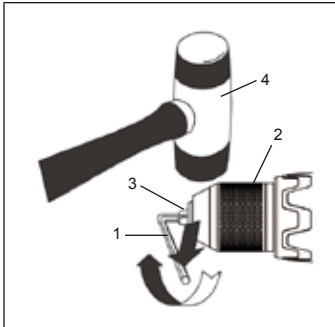

FIG. 13

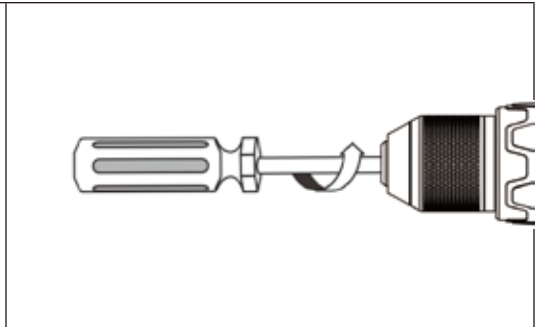

FIG. 14

5. Open the chuck jaws as far as possible.

6. Remove the chuck screw using a #2  screwdriver (Fig. 14).

NOTE: Turn the screw **CLOCKWISE** to remove it. This screw has a left-handed thread.

7. Insert the hex key into the chuck and tighten jaws of chuck securely (Fig. 15). Tap the hex key sharply with a mallet in a **COUNTER-CLOCKWISE** direction. This will loosen the chuck on the spindle. The chuck can now be unscrewed and removed from the spindle by hand.



FIG. 15

RETIGHTENING A LOOSE CHUCK

1. Remove the battery pack from the drill.

2. Insert a 5/16" (8 mm) or larger hex key (1) into the chuck (2) and tighten the chuck jaws securely (Fig. 16). Make sure each of the chuck jaws (3) is seated on the flat surfaces of the hex key.

3. Tap the hex key sharply with a mallet (4) in a **CLOCKWISE** direction. This action will loosen the screw in the chuck for easy removal.

4. Open the chuck jaws and remove the hex key.

5. Tighten the chuck screw using a #2  screwdriver (Fig 14).

NOTE: Turn the screw COUNTER-CLOCKWISE to tighten it. This screw has a left-handed thread.

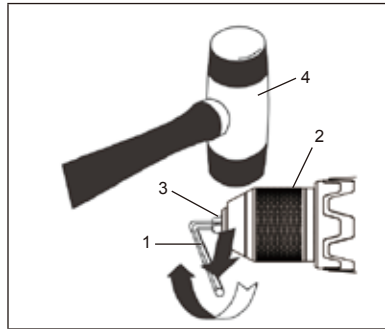

FIG. 16

MAINTENANCE

GENERAL

⚠️ WARNING: When servicing, use only identical replacement parts. The use of any other part may create a hazard or cause product damage.

DO NOT use solvents when cleaning plastic parts. Plastics are susceptible to damage from various types of commercial solvents and may be damaged by their use. Use a clean cloth to remove dirt, dust, oil, grease etc.

⚠️ WARNING: DO NOT allow brake fluids, gasoline, petroleum-based products, penetrating oils, etc. to come into contact with plastic parts. They contain chemicals that can damage, weaken, or destroy plastic.

DO NOT abuse power tools. Abusive practices can damage the tool and the workpiece.

⚠️ WARNING: DO NOT attempt to modify tools or create accessories. Any such alteration or modification is misuse and could result in a hazardous condition leading to possible serious injury. It will also void the warranty.

LUBRICATION

All of the bearings in this tool are lubricated with a sufficient amount of high-grade lubricant for the life of the unit under normal conditions. Therefore, no further lubrication is required.

BATTERY PACK REMOVAL AND PREPARATION FOR RECYCLING

To preserve our natural resources, please recycle or dispose of batteries properly. The batteries accompanying this tool may contain chemicals and metals that are harmful to the environment. Never dispose of rechargeable batteries in your normal household garbage or in landfill sites because they will add to the pollution of the environment.

Consult your local waste authority for information regarding available recycling and disposal options.

⚠ WARNING: Upon removal of the battery pack, cover the terminals of the battery pack with electrical tape or heavy-duty adhesive tape. Never touch both terminals with metal objects or body parts because a short circuit may result. Keep away from children. Do not attempt to destroy or disassemble battery pack or remove any of its components. Rechargeable batteries must be recycled or disposed of properly. Failure to comply with these warnings could result in fire and serious injury.

EXPLODED VIEW

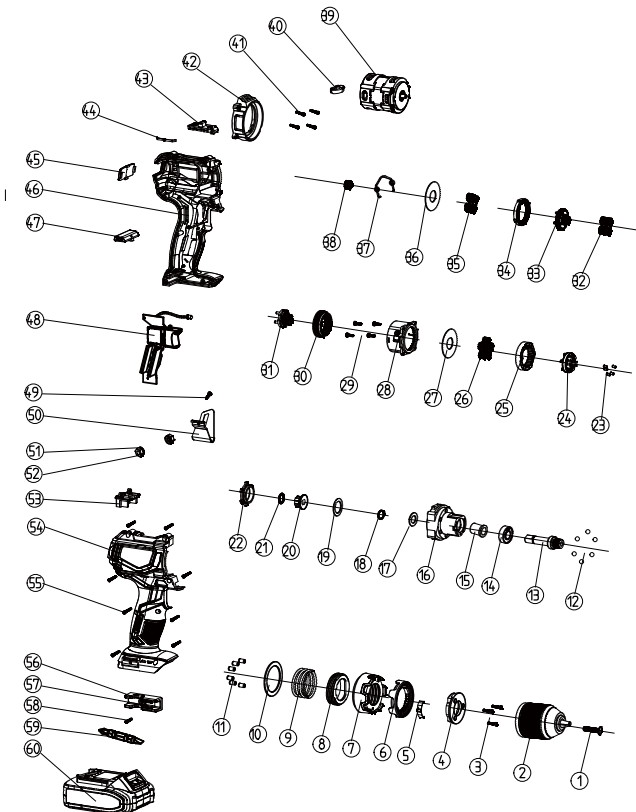

PARTS LIST

Always order by part number.

KEY #	PART #	PART NAME / QUANTITY	KEY #	PART #	PART NAME / QUANTITY
1	4020030020	Chuck Screw / 1	31	1170070087	Planetary carrier / 1
2	1140050026	Chuck / 1	32	2010010120	Planetary gear / 4
3	4030010253	Tapping Screw / 3	33	1170070085	Planetary carrier / 1
4	2020210007	Compressing Plate / 1	34	2010090075	Fixed ring gear / 4
5	2050070003	Position Spring / 1	35	2010010121	Planetary gear / 4
6	3110010236	Decorating Plate / 1	36	2030020242	Washer / 1
7	3120080134	Torque Setting Ring / 1	37	2050080180	2-speed lever / 1
8	3150190130	Inner Threaded Ring / 1	38	2010010119	Motor Gear / 1
9	2050080148	Spring / 1	39	1030300014	Brushless motor / 1
10	2030020228	Washer / 2	40	3160060085	lens/1
11	4110040014	Needle Roller / 6	41	4030010253	Tapping screw / 4
12	4080060001	Needle Roller / 6	42	3110010236	Decoration plate / 1
13	2040050148	Shaft / 1	43	3120120142	Speed selector button / 1
14	4010010092	Axletree / 2	44	2050070002	Lever/1
15	2010080127	Axle Sleeve / 1	45	3110010235	The tail of high / 1
16	3150070098	Gear Box / 1	46	3010010194	Left housing / 1
17	2030020101	Washer / 1	47	3120030133	FWD/REV lever / 1
18	4100020024	Circlip For Shaft / 1	48	1130030106	control circuit board/1
19	2030020214	Washer / 1	49	4020010168	Tapping screw / 1
20	2010230012	Driving Block / 1	50	2030100070	Belt buckle / 1
21	3140060071	O ring / 1	51	4040080003	Lock washer / 2
22	2040310058	Shaft lock ring / 1	52	4060010039	Hexagon nut / 2
23	4110020037	Needle roller / 5	53	3150170016	Contact plate / 1
24	1170070100	Planetary carrier / 1	54	3010010194	Right housing/1
25	2010090077	Gearing ring / 1	55	4030010253	Tapping screw / 7
26	2010010122	Planetary gear / 4	56	3150200008	bit shelf / 1
27	2030020023	Washer / 1	57	2030090039	bit clip / 1
28	3150080024	H/L speed switch box/1	58	4020010168	Tapping screw / 1
29	4030010003	Tapping screw / 4	59	6200070001	bit / 1
30	2010090076	Moveable ring gear / 1	60	1290090019	Battery Pack / 1

⚠ WARNING: When servicing, use only original equipment replacement parts. The use of any other parts may create a safety hazard or cause damage to the tool. Any attempt to repair or replace electrical parts on this tool may create a safety hazard unless repairs are performed by a qualified technician. For more information, call the Toll-free Helpline, at 1-866-349-8665.

WARRANTY

If this Benchmark tool fails due to a defect in material or workmanship within five years from the date of purchase, return it to any Home Hardware store with the original bill of sale for exchange. 3-year warranty for the battery and charger. This warranty does not include expendable parts including but not limited to blades, brushes, belts, light bulbs.

This warranty covers defects in material or workmanship only. It does not cover normal wear and tear, failure due to abuse/misuse, or defects caused by careless or accidental mishandling. If this Benchmark product is used for commercial or rental purposes, this warranty does not apply.

20V MAX BRUSHLESS 1/2" DRILL



5 Year Limited Warranty
3 Year Limited Warranty on
Battery and Charger

BENCHMARK™
MC

BENCHMARK TOOLS CANADA
ST. JACOBS, ONTARIO N0B 2N0
© 2020 Home Hardware Stores Limited

CUSTOMER SERVICE/TECH SUPPORT
1-866-349-8665

1239-170

Made in China



* This Benchmark™ product carries a five (5) year LIMITED warranty against defects in workmanship and materials. The charger and batteries carry a three (3) year LIMITED warranty. See Owner's Manual for full details.



Intertek

3042597
JD628620

**READ ALL INSTRUCTIONS BEFORE FIRST USE.
KEEP THIS MANUAL FOR FUTURE REFERENCE.
KEEP AWAY FROM CHILDREN.**

Maximum initial battery voltage (measured without a load)
is 20 volts. Nominal voltage is 18 volts.



**WEAR CSA APPROVED
EYE PROTECTION**



**WEAR EAR
PROTECTION**



**WEAR A
FACE MASK**