

BENCHMARKTM MC

20V MAX 6-1/2" CIRCULAR SAW



5 Year Limited Warranty
Battery and charger sold separately
Battery & charger included where applicable



E114847
JD539020

**READ ALL INSTRUCTIONS BEFORE FIRST USE.
KEEP THIS MANUAL FOR FUTURE REFERENCE.
KEEP AWAY FROM CHILDREN.**

Maximum initial battery voltage (measured without a load)
is 20 volts. Nominal voltage is 18 volts.



**WEAR CSA APPROVED
EYE PROTECTION**



**WEAR EAR
PROTECTION**



**WEAR A
FACE MASK**

PRODUCT SPECIFICATIONS

BENCHMARK 20V MAX 6-1/2" CIRCULAR SAW	
Voltage	20 V
No Load Speed	3800 RPM
Max cut at 90°	2" (54mm)
Max cut at 45°	1.5" (40mm)
Max cut at 50°	1-3/8" (35mm)
Blade	6-1/2" (165mm) Thin kerf 24T Carbide Tipped
Arbor	5/8"
Batteries (sold separately)	5350-023 (2.5Ah), 5350-011 (4Ah), 5350-012 (5Ah)
Charger (Sold separately)	5350-010 2.4Amp 5350-022 6A Fast Charger
Weight	5.1lbs (2.3kg)

NEED ASSISTANCE?

Call us on our toll-free customer support line:
1-866-349-8665 (Monday through Friday 9am – 5pm Eastern Standard Time)

- Technical questions
- Replacement parts
- Parts missing from package

TABLE OF CONTENTS









Product Specifications 1
Table of Contents 2
General Safety Warnings 3-6
Specific Safety Rules 7-9
Symbols 10
Know your Circular Saw 11
Assembly and Operating 12-15
Maintenance 16
Exploded View 17
Parts List 18-19
Warranty 20

GENERAL SAFETY WARNINGS

CAUTION:

Before using this tool or any of its accessories, read this manual and follow all Safety Rules and Operating Instructions.

EYE, EAR & LUNG PROTECTION

SYMBOL	MEANING
 DANGER  	<p>ALWAYS WEAR EYE PROTECTION THAT CONFORMS WITH CSA Z94.3 or ANSI SAFETY STANDARD Z87.1</p> <p>FLYING DEBRIS can cause permanent eye damage. Prescription eyeglasses ARE NOT a replacement for proper eye protection. Non-compliant eyewear can cause serious injury if broken during the operation of a power tool.</p>
 WARNING 	<p>Use hearing protection, particularly during extended periods of operation of the tool, or if the operation is noisy.</p>
 WARNING 	<p>WEAR A DUST MASK THAT IS DESIGNED TO BE USED WHEN OPERATING A POWER TOOL IN A DUSTY ENVIRONMENT.</p> <p>Dust that is created by power sanding, sawing, grinding, drilling, and other construction activities may contain chemicals that are known to cause cancer, birth defects, or other genetic abnormalities. These chemicals include:</p> <ul style="list-style-type: none"> • Lead from lead-based paints • Crystalline silica from bricks, cement, and other masonry products • Arsenic and chromium from chemically treated lumber. <p>The level of risk from exposure to these chemicals varies, according to how often this type of work is performed. In order to reduce exposure to these chemicals, work in a well-ventilated area, and use approved safety equipment, such as a dust mask that is specifically designed to filter out microscopic particles.</p>
 WARNING 	<p>To avoid electrical hazards, fire hazards or damage to the tool, use proper circuit protection.</p> <p>This tool is wired at the factory for 120 Volts AC operation. It must be connected to a 120 Volts AC, 15 Amps circuit that is protected by a time-delayed fuse or circuit breaker. To avoid shock or fire, replace power cord immediately if it is worn, cut or damaged in any way.</p>

WARNING:

Read all safety warnings and instructions. Failure to follow the warnings and instructions may result in electric shock, fire and/or serious injury.

Save all warnings and instructions for future reference.

WORK AREA SAFETY

Keep work area clean and well lit. Cluttered or dark areas invite accidents.

Do not operate power tools in explosive atmospheres, such as in the presence of flammable liquids, gases or dust. Power tools create sparks which may ignite the dust or fumes.

Keep children and bystanders away while operating the tool. Distractions can cause you to lose control.

ELECTRICAL SAFETY

Power tool plugs must match the outlet. Never modify the plug in any way. Do not use any adapter plugs with earthed (grounded) power tools. Unmodified plugs and matching outlets will reduce risk of electric shock.

Avoid body contact with earthed or grounded surfaces such as pipes, radiators, ranges, and refrigerators. There is an increased risk of electric shock if your body is earthed or grounded.

Do not expose power tools to rain or wet conditions. Water entering a power tool will increase the risk of electric shock.

Do not abuse the cord. Never use the cord for carrying, pulling, or unplugging the power tool. Keep cord away from heat, oil, sharp edges or moving parts. Damaged or entangled cords increase the risk of electric shock.

When operating a power tool outdoors, use an extension cord suitable for outdoor use. Use of a cord suitable for outdoor use reduces the risk of electric shock.

If operating a power tool in a damp location is unavoidable, use a residual current device (RCD) protected supply. Use of a ground fault circuit interrupter (GFCI) reduces the risk of electric shock.

PERSONAL SAFETY

Stay alert, watch what you are doing and use common sense when operating a power tool. Do not use a power tool while you are tired or under the influence of drugs, alcohol, or medication. A moment of inattention while operating power tools may result in serious personal injury.

Use personal protective equipment. Always wear eye protection. Protective equipment such as dust mask, non-skid safety shoes, hard hat, or hearing protection used for appropriate conditions will reduce personal injuries.

Prevent unintentional starting. Ensure the switch is in the OFF position before connecting to power source and/or battery pack, picking up or carrying the tool. Carrying power tools with your finger on the switch or energizing power tools that have the switch on invites accidents.

Remove any adjusting key or wrench before turning the power tool on. A wrench or a key left attached to a rotating part of the power tool may result in personal injury.

Do not overreach. Keep proper footing and balance at all times. This enables better control of the power tool in unexpected situations.

Dress properly. Do not wear loose clothing or jewellery. Keep your hair, clothing, and gloves away from moving parts. Loose clothes, jewellery or long hair can be caught in moving parts.

If devices are provided for the connection of dust extraction and collection facilities, ensure these are connected and properly used. Use of dust collection can reduce dust- related hazards.

Do not force the power tool. Use the correct power tool for your application. The correct power tool will do the job better and safer at the rate for which it was designed.

Do not use the power tool if the switch does not turn it on and off. Any power tool that cannot be controlled with the switch is dangerous and must be repaired.

Disconnect the plug from the power source and/or the battery pack from the power tool before making any adjustments, changing accessories, or storing power tools. Such preventive safety measures reduce the risk of starting the power tool accidentally.

Store idle power tools out of the reach of children and do not allow persons unfamiliar with the power tool or these instructions to operate the power tool. Power tools are dangerous in the hands of untrained users.

Maintain power tools. Check for misalignment or binding of moving parts, breakage of parts and any other condition that may affect the power tool's operation. If damaged, have the power tool repaired before use. Many accidents are caused by poorly maintained power tools.

Keep cutting tools sharp and clean. Properly maintained cutting tools with sharp cutting edges are less likely to bind and are easier to control.

Use the power tool, accessories, and tool bits etc. in accordance with these instructions, taking into account the working conditions and the work to be performed. Use of the power tool for operations different from those intended could result in a hazardous situation.

Hold power tool by insulated gripping surfaces when performing an operation where the cutting tool may contact hidden wiring or its own cord. Contact with a "live" wire will make exposed metal parts of the tool "live" and shock the operator.

Use clamps or another practical way to secure and support the workpiece to a stable platform. Holding the work by hand or against your body leaves it unstable and may lead to loss of control.

BATTERY TOOL USE AND CARE

Recharge only with the charger specified by the manufacturer. A charger that is suitable for one type of battery pack may create a risk of fire when used with another battery pack. Use power tools only with specifically designated battery packs. Use of any other battery packs may create a risk of injury and fire. When battery pack is not in use, keep it away from other metal objects, like paper clips, coins, keys, nails, screws, or other small metal objects that can make a connection from one terminal to another. Shorting the battery terminals together may cause burns or a fire. Under abusive conditions, liquid may be ejected from the battery; avoid contact. If contact accidentally occurs, flush with water. If liquid contacts eyes, additionally seek medical help. Liquid ejected from the battery may cause irritation or burns.

SERVICE

Have your power tool serviced by a qualified repair person using only identical replacement parts. This will ensure that the safety of the power tool is maintained.

SAVE THESE INSTRUCTIONS FOR REFERENCE

SPECIFIC SAFETY RULES

WARNING:

Know your circular saw. Do not plug in the charger or install the battery until you have read and understand this Instruction Manual. Learn the tool's applications and limitations, as well as the specific potential hazards related to this tool.

Following this rule will reduce the risk of electric shock, fire, or serious injury.



Always wear eye protection. Any power tool can throw foreign objects into your eyes and cause permanent eye damage. ALWAYS wear safety goggles (not glasses) that comply with ANSI safety standard Z87.1. Everyday glasses have only impact resistant lenses. They ARE NOT safety glasses.

WARNING:

Glasses or goggles not in compliance with ANSI Z87.1 could cause serious injury when they break.

Always keep hands out of the path of the saw blade. Avoid awkward hand positions where a sudden slip could cause your hand to move into the path of the saw blade.

 **DANGER: Keep hands away from cutting area and the blade. Keep your second hand on the tool.** If both hands are holding the saw, they cannot be cut by the blade.

Do not reach underneath the workpiece. The guard cannot protect you from the blade below the workpiece.

Adjust the cutting depth according to the thickness of the workpiece. Less than a full tooth of the blade teeth should be visible below the workpiece or approximately 3/8" (10 mm).

Never hold piece being cut in your hands or across your leg. Secure the workpiece to a stable platform. It is important to support the work properly to minimize body exposure, blade binding, or loss of control.

Hold power tool by insulated gripping surfaces when performing an operation where the cutting tool may contact hidden wiring or its own cord. Contact with a "live" wire will also make exposed metal parts of the power tool "live" and shock the operator.

When ripping always use a straight edge guide. This improves the accuracy of cut and reduces the chance of the blade binding.

Always use blades with correct size and shape (diamond versus round) of arbor holes. Blades that do not match the mounting hardware of the saw will run eccentrically, causing loss of control.

Never use damaged or incorrect blade washers or bolt. The blade washers and bolt were specially designed for your saw, for optimum performance and safety of operation.

CAUSES AND OPERATOR PREVENTION OF KICKBACK

Kickback is a sudden reaction to a pinched, bound, or misaligned saw blade, causing an uncontrolled saw to lift up and out of the workpiece toward the operator.

When the blade is pinched or bound tightly by the kerf closing down, the blade stalls and the motor reaction drives the unit rapidly back toward the operator.

If the blade becomes twisted or misaligned in the cut, the teeth at the back edge of the blade can dig into the top surface of the wood causing the blade to climb out of the kerf and jump back toward the operator.

Kickback is the result of saw misuse and/or incorrect operating procedures or conditions and can be avoided by taking proper precautions as given below:

Maintain a firm grip with both hands on the saw and position your arms to resist kickback forces. Position your body to the left or right side of the blade, but not in line with the blade. Kickback could cause the saw to jump backwards, but kickback forces can be controlled by the operator, if proper precautions are taken.

When the blade is binding, or when interrupting a cut for any reason, release the trigger and hold the saw motionless in the material until the blade comes to a complete stop. Never attempt to remove the saw from the work or pull the saw backward while the blade is in motion or kickback may occur. Investigate and take corrective actions to eliminate the cause of blade binding.

When restarting a saw in the workpiece, centre the saw blade in the kerf and check that saw teeth are not engaged into the material. If the saw blades are binding, it may walk up or kickback from the workpiece as the saw is restarted.

Support large panels to minimize the risk of blade pinching and kickback. Large panels tend to sag under their own weight. Supports must be placed under the panel on both sides, near the line of cut and near the edge of the panel.

Do not use dull or damaged blades. Unsharpened or improperly set blades produce narrow kerf causing excessive friction, blade binding and kickback.

Use extra caution when making a "plunge cut" into existing walls or other blind areas. The protruding blade may cut into electric wires or objects that can cause kickback.

Check the lower guard for proper closing before each use. Do not operate the saw if the lower guard does not move freely and close instantly. Never clamp or tie the lower guard into the open position. If the saw is accidentally dropped, the lower guard may be damaged. Raise the lower guard with the retracting handle and make sure it moves freely and does not touch the blade or any other part in all depths of cuts.

Check the operation of the lower guard spring. If the guard and the spring are not operating properly, they must be serviced before use. The lower guard may operate sluggishly due to damaged parts, gummy deposits, or a build-up of debris.

The lower guard should be retracted manually only for special cuts such as "plunge cuts" and "compound cuts". Raise lower guard by retracting handle and as soon as the blade enters the material, the lower guard must be released. For all other sawing, the lower guard should operate automatically.

Always observe that the lower guard is covering the blade before placing saw down on the bench or on the floor. An unprotected, coasting blade will cause the saw to walk backwards, cutting whatever is in its path. Be aware of the time it takes for the blade to stop after the switch is released.

Never operate the saw while it is being carried to another location. The blade guard may be open and potentially cause serious injury.

If the switch fails to turn the saw ON or OFF properly, stop using it immediately and have the saw switch repaired.

Always allow the saw to reach full speed before beginning the cut.

Never use the side of the blade for cutting. When making horizontal cuts, make sure the weight of the tool is not forcing the side of the blade to do the cutting. This will reduce the risk of kickback.

Make sure there are no nails or foreign objects in the area of the workpiece to be cut.

Never lay workpiece on hard surfaces like concrete, stone, etc. The protruding blade may cause tool to jump.

⚠️ DANGER: To avoid injury from accidental starting, always remove the battery before making any adjustments and before installing or removing a saw blade.

When replacing the blade, make sure the replacement blade is 6 1/2" in diameter and is rated for at least 3,800 RPM. Installing an incorrect blade will result in possible injury and poor cutting action.











After changing a blade or making adjustments make sure the blade clamp screw is securely tightened. Loose blades and adjustment devices will be violently thrown.

Never touch the blade during or immediately after use. After use, the blade is too hot to be safely touched with bare hands.

SAVE THESE INSTRUCTIONS FOR REFERENCE

SYMBOLS

⚠️ WARNING: Some of the following symbols may appear on the saw. Study these symbols and learn their meaning. Proper interpretation of these symbols will allow for more efficient and safer operation of this tool.

V	Volts	3ϕ 	Three-phase alternating current with neutral
A	Amperes		Direct current
Hz	Hertz	n_0	No load speed
W	Watts		Alternating or direct current
kW	Kilowatts		Class II Construction
μF	Microfarads		Splash-proof construction
L	Litres		Watertight construction
kg	Kilograms		Protective grounding at terminal, Class I tools
H	Hours	.../min	Revolutions or reciprocations per minute
N/cm ²	Newtons per square centimetre	\varnothing	Diameter
Pa	Pascals	0	Off position
OPM	Oscillations per minute		Directional Arrow
Min	Minutes		Warning symbol
S	Seconds		Wear your safety glasses
\sim or AC	Alternating current		Keep hands away from blade
3 \sim	Three-phase alternating current		



This symbol designates that this tool is listed with U.S. requirements by MET Laboratories, Inc.

UL62841-1, UL62841-2-5 CSA C22.2#UL62841-1, UL62841-2-5.

E114847
JD539020

KNOW YOUR 20V CIRCULAR SAW

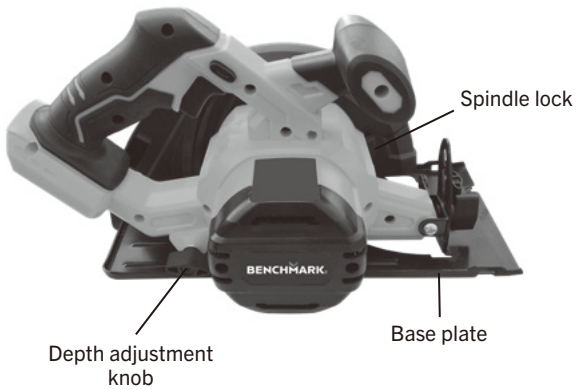
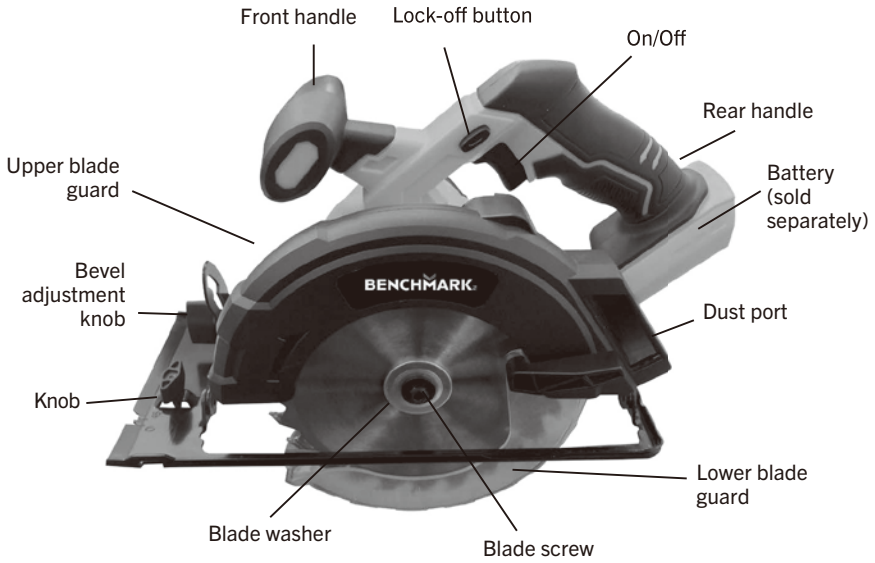

ASSEMBLY AND OPERATING

INSTALLING THE BLADE

⚠ WARNING: Always remove the battery from the saw before installing or removing a blade or adjusting the saw in any way.

1. Depress the spindle lock button Fig.1.
2. Remove the blade screw by turning it clockwise with the hex key, while keeping the spindle lock button depressed Fig.2.
3. Remove the blade washer noting which way round it is fitted.
4. Fit the saw blade inside the lower blade guard and onto the spindle ensuring that the direction of rotation arrow on the blade corresponds with the direction of rotation arrow on the fixed guard arrow.

NOTE: The saw teeth point upward at the front of the saw.

5. Replace the blade washer. Depress the spindle lock button, then replace the blade screw. Tighten the blade screw securely by turning it counterclockwise.

NOTE: Check the tightness of the blade securing bolt before, during and after each use.



Fig. 1

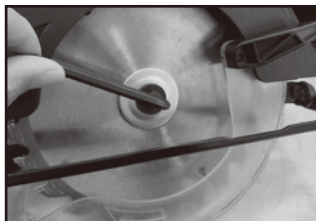

Fig. 2

ATTACHING THE EDGE GUIDE

Before attaching the edge guide, please ensure the battery is removed from the tool.

Place the edge guide through the holes in the base.

Adjust the edge guide to the width needed and then tighten the edge guide locking knob making sure the guide is secure.

Note: Use the edge guide provided when making long or wide rip cuts with the saw.

⚠ WARNING: Before each use always check the operation of the lower guard before connecting the battery to the Circular Saw. Do not use the Circular Saw if the lower guard does not close smoothly over the saw blade and returns fully to the closed position.

Keep blades clean & sharp.

When handling blades wear gloves.

⚠️ WARNING: For safety reasons, the operator must read the sections of this Owner's Manual entitled "GENERAL SAFETY WARNINGS", "POWER TOOL SAFETY", "SPECIFIC SAFETY RULES", "EXTENSION CORD SAFETY" and "SYMBOLS" before using this circular saw.

Verify the following every time the circular saw is used:

- 1. The blade is tight and sharp.**
 - 2. All adjustments are tight.**
 - 3. The workpiece is properly secured.**
 - 4. Safety glasses and hearing protection are being worn.**
- Failure to adhere to these safety rules can greatly increase the chances of injury.**

DEPTH OF CUT AT 90°

Always keep correct blade depth setting. The correct blade depth setting for all cuts should not exceed 1/4 in. below the material being cut. More blade depth will increase the chance of kickback and cause the cut to be rough. For more depth of cut accuracy, a scale is located on the upper blade guard.

The Circular Saw has an adjustable depth of cut. To adjust the depth of cut, slacken the lever located on the side of the machine, Fig.3.

Measure the depth required from the base plate to the highest point of the blade or use the depth gauge on the fixed guard, Fig.4.

Tighten the depth adjustment knob securely.

ANGLE OF CUT 0-45°

To adjust the angle of cut between 0-45° slacken the adjustable angle of cut locking knob.

The base plate assembly will now pivot between 0-45°. Set the desired cutting angle by using degree scale at the front of the machine and tighten locking knobs.

At the front of the base plate there are two notches marked 0° and 45°. These notches are a guide to indicate the position of the blade in relation to the cut being made in the material.



Fig. 3

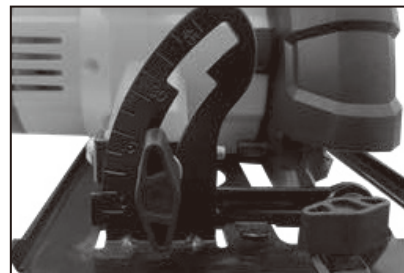

Fig. 4

TRIGGER SWITCH AND LOCK OFF

1. To turn the saw ON, press in the lock-off switch (2) from either the right or left side, then depress and hold in the trigger switch (1) (Fig. 5).

⚠ WARNING: Never carry the saw with your finger on the trigger switch. The saw could be accidentally started and cause severe personal injury.

2. To turn the saw OFF, release the trigger switch.

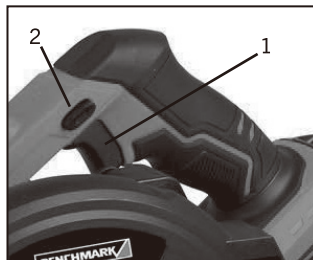

Fig. 5

MATERIALS THAT YOU CAN CUT

The circular saw is a versatile saw that allows you to cut many different types of materials. Some of the materials include:

- Wood products such as lumber, hardwood, plywood, composite board, and paneling
- Drywall
- Masonite and plastic

NOTE: There are several different types of blades available. Generally, blades with carbide-tipped teeth cut better and stay sharp longer. Tooth count and configuration are also important. High tooth counts cut slower and are best suited for making smooth cuts on thinner materials such as paneling. Use the correct blade for your application.

GENERAL CUTTING

1. Make any adjustments to the saw before installing the blade. Adjustments include cutting depth, cutting angle and rip guide (if installed).
2. Clearly mark the workpiece to locate the position of the cut.
3. Hold a smaller workpiece with a vise. Clamp a larger workpiece to a workbench or table.

⚠ DANGER: Any workpiece that is not adequately clamped in place may come loose and cause serious injury. Never hold the workpiece in your hand.

4. Make sure there are no nails, screws, clamps, or foreign materials in the path of the saw blade.
5. With both hands firmly gripping the saw, and with the blade NOT in contact with the surface to be cut, start the saw by squeezing the trigger switch.
6. Once the saw has reached full speed, place the front edge of the sole plate on the workpiece and gradually bring the moving blade into contact with the workpiece at the appropriate location.

DO NOT abuse power tools. Abusive practices can damage the tool and the workpiece.

⚠️ WARNING: DO NOT attempt to modify tools or create accessories. Any such alteration or modification is misuse and could result in a hazardous condition leading to possible serious injury. It will also void the warranty.

MAINTENANCE

⚠️ WARNING: When servicing, use only identical replacement parts. The use of any other part may create a hazard or cause product damage.

DO NOT use solvents when cleaning plastic parts. Plastics are susceptible to damage from various types of commercial solvents and may be damaged by their use. Use a clean cloth to remove dirt, dust, oil, grease etc.

⚠️ WARNING: Do not allow brake fluids, gasoline, petroleum-based products, penetrating oils, etc. to come into contact with plastic parts. They contain chemicals that can damage, weaken, or destroy plastic.

It has been found that electric tools are subjected to accelerated wear and possible premature failure when they are used on fiberglass boats and sports cars, wallboard, spackling compounds, or plaster. The chips and grindings from these materials are highly abrasive to electric tool parts such as bearings, brushes, commutators, etc. Consequently, it is not recommended that this tool be used for extended work on any fiberglass material, wallboard, spackling compounds, or plaster. During any use on these materials, it is extremely important that the tool is cleaned frequently by blowing it out with an air jet.

⚠️ WARNING: Always wear safety goggles or safety glasses with side shields during all cutting operations. It is critical that you also wear safety goggles or safety glasses with dust out of the circular saw with an air jet. Failure to take these safety precautions could result in permanent eye or lung damage.

If the motor brushes require replacement, contact the toll-free customer support line: 1-866-349-8665 Monday – Friday from 9am to 5pm Eastern Standard Time

LUBRICATION

All of the bearings in this tool are lubricated with a sufficient amount of high-grade lubricant for the life of the unit under normal conditions.

Therefore, no further lubrication is required.

EXPLODED VIEW

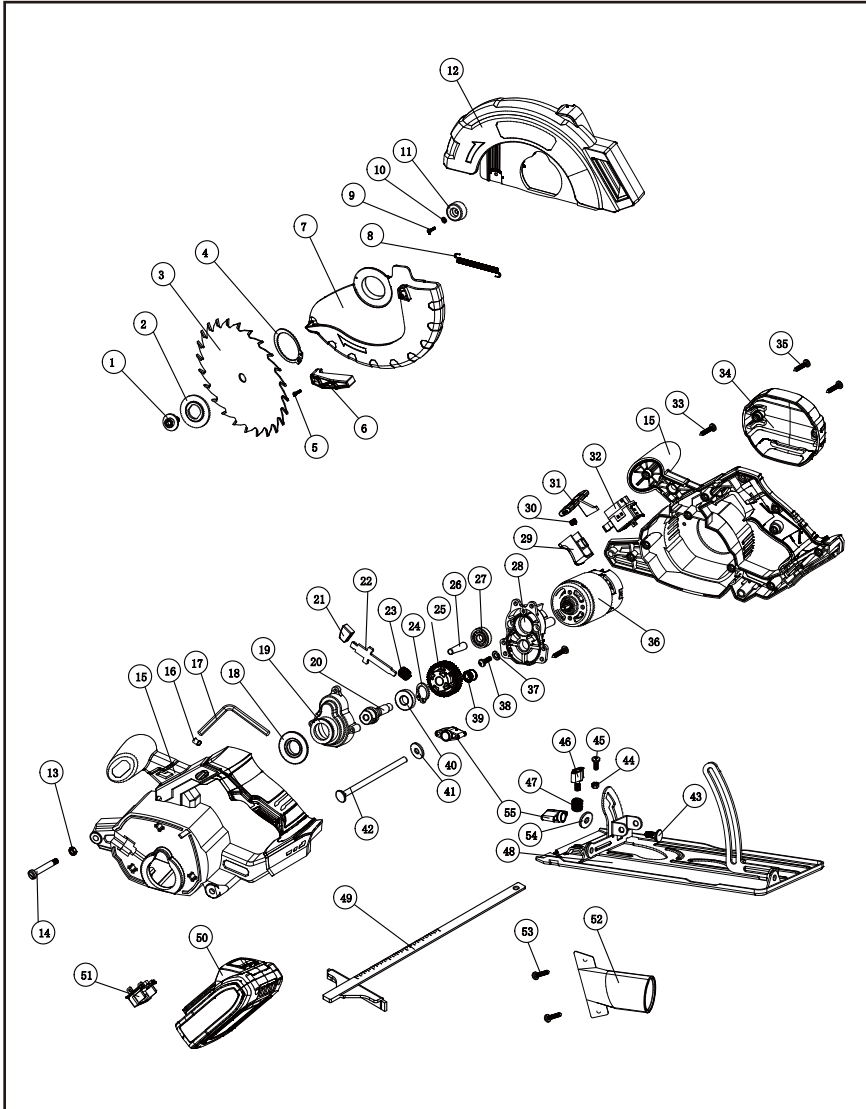

PARTS LIST

⚠️ WARNING When servicing, use only original equipment replacement parts. The use of any other parts may create a safety hazard or cause damage to the tool. Any attempt to repair or replace electrical parts on this tool may create a safety hazard unless repairs are performed by a qualified technician. For more information, call the Toll-free Helpline, at 1-866-349-8665.

Always order by PART NUMBER, not by key number.

Key #	Part #	Part Name	Quantity
1	2040140053	Screw	1
2	2030030246	Blade washer	1
3	6070030004	Circular blade	1
4	4100020014	Elastic collar 28	1
5	4030010067	ST2.9X10	1
6	3120100063	Lower guard lever	1
7	3160040119	Lower guard	1
8	2050060278	Guard return spring	1
9	4030010106	ST3. 9X19	1
10	4040010025	Flat washer	1
11	3140090025	Guard stop block	1
12	3160040120	Upper blade guard	1
13	4060090001	Nut	1
14	2040140057	Screw	1
15	3010070024	Housing	1
16	3140090015	Rubber sleeve	1
17	6140020006	Wrench	1
18	2010140053	Washer	1
19	3160090098	Gear box cover	1
20	2040050146	Shaft	1
21	3120020141	Lock screw cap	1
22	2030250022	The spindle lock level	1
23	2050060233	Spring	1
24	4100020012	Elastic collar	1
25	2010020018	Big gear	1
26	2040070016	Motor gear	1
27	4010010022	Deep groove ball bearing	2
28	3150070095	Gear box	1
29	3120010101	On/off trigger button	1
30	2050060218	Switch lock lever spring	1

Key #	Part #	Part Name	Quantity
31	3120040080	Switch lock lever	1
32	1060190008	Switch	1
33	4030010106	ST3.9X19	3
34	3160010079	Rear cap	1
35	4030010074	ST3.9X14	20
36	1030240004	Motor	1
37	4040030003	Spring washer	2
38	4020010170	Screw	2
39	4010020044	Needle bearing	1
40	4010010022	Deep groove ball bearing	2
41	2030020116	Gasket	1
42	4050040015	Bolt	1
43	4050040014	Bolt	1
44	4060010005	Nut	1
45	4020010053	Screw	1
46	1180050051	Rotary knob	1
47	2050060228	Spring	1
48	1150020131	Baseplate	1
49	6210040013	Parallel Guide	1
50	1290090019	Battery (not included)	0
51	1180060030	Battery plate	1
52	3180040132	Dust exhaust port	1
53	4030010102	Screws	1
54	2030020017	Gasket	1
55	1180050050	Bevel setting knob	2

WARRANTY

BENCHMARK 20V MAX 6-1/2" CIRCULAR SAW

If this Benchmark tool fails due to a defect in material or workmanship within five years from the date of purchase, return it to any Home Hardware store with the original bill of sale for exchange. 3-year warranty for the battery and charger. This warranty does not include expendable parts including but not limited to blades, brushes, belts, light bulbs.

This warranty covers defects in material or workmanship only. It does not cover normal wear and tear, failure due to abuse/misuse, or defects caused by careless or accidental mishandling. If this Benchmark product is used for commercial or rental purposes, this warranty does not apply.

20V MAX 6-1/2" CIRCULAR SAW



5 Year Limited Warranty
Battery and charger sold separately

BENCHMARKTM_{MC}

BENCHMARK TOOLS CANADA

ST. JACOBS, ONTARIO N0B 2N0

© 2021 Home Hardware Stores Limited

CUSTOMER SERVICE/TECH SUPPORT

1-866-349-8665

1239-104

Made in China



* This BenchmarkTM product carries a five (5) year LIMITED warranty against defects in workmanship and materials. The charger and batteries carry a three (3) year LIMITED warranty. See Owner's Manual for full details.



E114847
JD539020

**READ ALL INSTRUCTIONS BEFORE FIRST USE.
KEEP THIS MANUAL FOR FUTURE REFERENCE.
KEEP AWAY FROM CHILDREN.**

Maximum initial battery voltage (measured without a load)
is 20 volts. Nominal voltage is 18 volts.



**WEAR CSA APPROVED
EYE PROTECTION**



**WEAR EAR
PROTECTION**



**WEAR A
FACE MASK**

BENCHMARKTM MC

20V MAX 1/2" DRILL



5 Year Limited Warranty on tool
3 Year Limited Warranty on battery and charger
Battery & charger included where applicable



JD6318H20

**READ ALL INSTRUCTIONS BEFORE FIRST USE.
KEEP THIS MANUAL FOR FUTURE REFERENCE.
KEEP AWAY FROM CHILDREN.**

Maximum initial battery voltage (measured without a load)
is 20 volts. Nominal voltage is 18 volts.



**WEAR CSA APPROVED
EYE PROTECTION**



**WEAR EAR
PROTECTION**



**WEAR A
FACE MASK**

PRODUCT SPECIFICATIONS

DRILL	
Variable chuck speed	0–450 RPM / 0–1,600 RPM (no load)
Torque clutch positions	16 + drill mode
Keyless chuck	½" keyless
Max torque	380 in/lbs.
Weight	3.8lbs. (1.73kg)
BATTERY & CHARGER	
Battery	20V 2.5Ah Li-ion (Maximum charged battery voltage, measured without load, is 20V with a nominal value of 18V)
Replacement battery	5350-023 (2.5Ah) Charge time – up to 75 minutes)
Replacement charger assembly	5350-010 (2.4A)

NEED ASSISTANCE?

Call us on our toll-free customer support line:
1-866-349-8665 (Monday through Friday 9am – 5pm Eastern Standard Time)

- Technical questions
- Replacement parts
- Parts missing from package

TABLE OF CONTENTS











Product Specifications 1
Table of Contents 2
General Safety Warnings 3-6
Specific Safety Rules 7-8
Battery & Charger Safety 8-9
Symbols 10
Know your Cordless 20V 2VSR Drill 11
Assembly and Operating 12-19
Maintenance 20
Exploded View 21
Parts List 22-23
Warranty 24

GENERAL SAFETY WARNINGS

WARNING:

Before using this tool or any of its accessories, read this manual and follow all Safety Rules and Operating Instructions. The important precautions, safeguards and instructions appearing in this manual are not meant to cover all possible situations. It must be understood that common sense and caution are factors which cannot be built into the product.

EYE, EAR & LUNG PROTECTION

SYMBOL	MEANING
 DANGER  	<p>ALWAYS WEAR EYE PROTECTION THAT CONFORMS WITH CSA Z94.3 or ANSI SAFETY STANDARD Z87.1</p> <p>FLYING DEBRIS can cause permanent eye damage. Prescription eyeglasses ARE NOT a replacement for proper eye protection. Non-compliant eyewear can cause serious injury if broken during the operation of a power tool.</p>
 WARNING 	<p>Use hearing protection, particularly during extended periods of operation of the tool, or if the operation is noisy.</p>
 WARNING 	<p>WEAR A DUST MASK THAT IS DESIGNED TO BE USED WHEN OPERATING A POWER TOOL IN A DUSTY ENVIRONMENT.</p> <p>Dust that is created by power sanding, sawing, grinding, drilling, and other construction activities may contain chemicals that are known to cause cancer, birth defects, or other genetic abnormalities. These chemicals include:</p> <ul style="list-style-type: none"> • Lead from lead-based paints • Crystalline silica from bricks, cement, and other masonry products • Arsenic and chromium from chemically treated lumber. <p>The level of risk from exposure to these chemicals varies, according to how often this type of work is performed. In order to reduce exposure to these chemicals, work in a well-ventilated area, and use approved safety equipment, such as a dust mask that is specifically designed to filter out microscopic particles.</p>
 WARNING 	<p>To avoid electrical hazards, fire hazards or damage to the tool, use proper circuit protection.</p> <p>This tool is wired at the factory for 120 Volts AC operation. It must be connected to a 120 Volts AC, 15 Amps circuit that is protected by a time-delayed fuse or circuit breaker. To avoid shock or fire, replace power cord immediately if it is worn, cut or damaged in any way.</p>
 WARNING 	<p>Ventilation openings in batteries and chargers must always be open to allow cooling air to circulate freely. Air vents that are blocked, restricted, or covered may result in the battery or charger overheating. Overheating may lead to damage to the tool or cause a fire, resulting in possible serious injury.</p>

 **WARNING:**

Read all safety warnings and instructions. Failure to follow the warnings and instructions may result in electric shock, fire and/or serious injury.

SAVE ALL WARNINGS AND INSTRUCTIONS FOR FUTURE REFERENCE.

WORK AREA SAFETY

Keep work area clean and well lit. Cluttered or dark areas invite accidents.

Do not operate power tools in explosive atmospheres, such as in the presence of flammable liquids, gases or dust. Power tools create sparks which may ignite the dust or fumes.

Keep children and bystanders away while operating a power tool. Distractions can cause you to lose control.

ELECTRICAL SAFETY

Power tool plugs must match the outlet. Never modify the plug in any way. Do not use any adapter plugs with earthed (grounded) power tools. Unmodified plugs and matching outlets will reduce risk of electric shock.

Avoid body contact with earthed or grounded surfaces such as pipes, radiators, ranges, and refrigerators. There is an increased risk of electric shock if your body is earthed or grounded.

Do not expose power tools to rain or wet conditions. Water entering a power tool will increase the risk of electric shock.

Do not abuse the cord. Never use the cord for carrying, pulling, or unplugging the power tool. Keep cord away from heat, oil, sharp edges or moving parts. Damaged or entangled cords increase the risk of electric shock.

When operating a power tool outdoors, use an extension cord suitable for outdoor use. Use of a cord suitable for outdoor use reduces the risk of electric shock.

If operating a power tool in a damp location is unavoidable, use a residual current device (RCD) protected supply. Use of a ground fault circuit interrupter (GFCI) reduces the risk of electric shock.

PERSONAL SAFETY

Stay alert, watch what you are doing and use common sense when operating a power tool. Do not use a power tool while you are tired or under the influence of drugs, alcohol, or medication. A moment of inattention while operating power tools may result in serious personal injury.

Use personal protective equipment. Always wear eye protection. Protective equipment such as dust mask, non-skid safety shoes, hard hat, or hearing protection used for appropriate conditions will reduce personal injuries.

Prevent unintentional starting. Ensure the switch is in the off position before connecting to power source and/or battery pack, picking up or carrying the tool. Carrying power tools with your finger on the switch or energizing power tools that have the switch on invites accidents.

Remove any adjusting key or wrench before turning the power tool on. A wrench or a key left attached to a rotating part of the power tool may result in personal injury.

Do not overreach. Keep proper footing and balance at all times. This enables better control of the power tool in unexpected situations.

Dress properly. Do not wear loose clothing or jewellery. Keep your hair, clothing, and gloves away from moving parts. Loose clothes, jewellery or long hair can be caught in moving parts.

If devices are provided for the connection of dust extraction and collection facilities, ensure these are connected and properly used. Use of dust collection can reduce dust-related hazards.

POWER TOOL USE AND CARE

Do not force the power tool. Use the correct power tool for your application. The correct power tool will do the job better and safer at the rate for which it was designed.

Do not use the power tool if the switch does not turn it on and off. Any power tool that cannot be controlled with the switch is dangerous and must be repaired.

Disconnect the plug from the power source and/or the battery pack from the power tool before making any adjustments, changing accessories, or storing power tools. Such preventive safety measures reduce the risk of starting the power tool accidentally.

Store idle power tools out of the reach of children and do not allow persons unfamiliar with the power tool or these instructions to operate the power tool. Power tools are dangerous in the hands of untrained users.

Maintain power tools. Check for misalignment or binding of moving parts, breakage of parts and any other condition that may affect the power tool's operation. If damaged, have the power tool repaired before use. Many accidents are caused by poorly maintained power tools.

Keep cutting tools sharp and clean. Properly maintained cutting tools with sharp cutting edges are less likely to bind and are easier to control.

Use the power tool, accessories, and tool bits etc. in accordance with these instructions, taking into account the working conditions and the work to be performed. Use of the power tool for operations different from those intended could result in a hazardous situation.

Hold power tool by insulated gripping surfaces, when performing an operation where the fastener may contact hidden wiring or its own cord. Fasteners contacting a "live" wire may make exposed metal parts of the power tool "live" and could give the operator an electric shock.

BATTERY TOOL USE AND CARE

Recharge only with the charger specified by the manufacturer. A charger that is suitable for one type of battery pack may create a risk of fire when used with another battery pack.

Use power tools only with specifically designated battery packs. Use of any

other battery packs may create a risk of injury and fire.

When battery pack is not in use, keep it away from other metal objects, like paper clips, coins, keys, nails, screws, or other small metal objects that can make a connection from one terminal to another. Shorting the battery terminals together may cause burns or a fire.

Under abusive conditions, liquid may be ejected from the battery; avoid contact. If contact accidentally occurs, flush with water. If liquid contacts eyes, additionally seek medical help. Liquid ejected from the battery may cause irritation or burns.

SERVICE

Have your power tool serviced by a qualified repair person using only identical replacement parts. This will ensure that the safety of the power tool is maintained.

SPECIFIC SAFETY RULES

WARNING:

Know your cordless drill. Do not plug in the charger or install the battery in the tool until you have read and understand this Instruction Manual. Learn the tool's applications and limitations, as well as the specific potential hazards related to this tool. Following this rule will reduce the risk of electric shock, fire, or serious injury.



Always wear eye protection. Any power tool can throw foreign objects into your eyes and cause permanent eye damage. ALWAYS wear safety goggles (not glasses) that comply with ANSI safety standard Z87.1. Everyday glasses have only impact resistant lenses. They ARE NOT safety glasses.

WARNING:

Glasses or goggles not in compliance with ANSI Z87.1 could cause serious injury when they break.

WARNING:

Always use a safety shield, hearing protection and dust mask when drilling concrete.

WARNING:

To avoid fire or toxic reaction, never use gasoline, naphtha, acetone, lacquer thinner or similar highly volatile solvents to clean the tool.

WARNING:

Use only accessories that are recommended for this cordless drill. Follow the instructions that accompany the accessories. The use of improper accessories may result in injury.

 **WARNING:** If any part is missing or damaged, do not plug the tool into the power source or install any accessory until the missing or damaged part is replaced.

Do not drill material too small to be securely held.

Always keep hands out of the path of the drill bit. Avoid awkward hand positions where a sudden slip could cause your hand to move into the path of the drill bit.

Secure the workpiece. Use clamps or a vice to hold the workpiece. It is safer than using your hand and it frees both hands to operate the tool.

Make sure there are no nails or foreign objects in the part of the workpiece to be drilled.

To avoid injury from accidental starting, always remove the battery from the tool before installing or removing a drill bit.

Do not install or use any drill bit that exceeds 7" (17.5 cm) in length or extends more than 6" (15 cm) beyond the chuck jaws. They can bend or break suddenly.

Before starting the operation, jog the drill switch to make sure the drill bit does not wobble or vibrate.

Do not use fly cutters or multiple-part hole cutters, because they can come apart or become unbalanced during use.

Make sure the spindle has come to a complete stop before touching the chuck or attempting to change the drill bit.

Always make sure the chuck is tight and the drill bit firmly tightened in the chuck before starting drill.

BATTERY & CHARGER SAFETY

WARNING:

Only use the charger supplied with this kit to charge the 20V Li-ion batteries for this tool. Charging any other batteries may damage the charger and possibly cause serious injury.

Do not store or carry the battery in a manner in which metal objects could contact the exposed metal end. Do not place the battery in aprons, pockets, drawers, etc. with loose nails, screws, keys etc. The battery could short circuit causing a fire, personal injury, or damage to the battery.

Never attempt to open the battery for any reason. If the housing of the battery breaks or cracks, immediately discontinue use and do not recharge.

Do not charge the battery if it is wet or shows any evidence of corrosion.

A small leakage from the battery may occur under extreme usage, charging or temperature conditions. This does not indicate a failure. However, if the outer seal is broken and this leakage gets on your skin, follow these steps:

1. Wash immediately with soap and water.
2. Neutralize with a mild acid such as lemon juice or vinegar.
3. If liquid gets into your eyes, flush immediately with clean water for a minimum of 10 minutes and seek medical attention.

NOTE: The battery liquid is slightly acidic.

Do not incinerate the battery. It can explode in a fire.

Do not use an extension cord. Plug the charger cord directly into an electrical outlet.

Use the charger only in a standard 120V, 60 Hz electrical outlet.

Do not use the charger in wet or damp conditions. It is intended for indoor use only.

Do not use the charger near sinks or tubs. Do not immerse the charger in water.

Do not allow the cord to hang over the edge of a table or counter or touch hot surfaces.

The charger should be placed away from sinks and hot surfaces.

Do not use the charger to charge any batteries other than the cordless drill batteries. Other batteries may explode.

Do not allow the cord to hang over the edge of a table or counter or touch hot

surfaces. The charger should be placed away from sinks and hot surfaces.

Do not operate charger if the cord or plug is damaged. Replace the damaged cord and plug immediately.

Do not operate the charger if it has received a sharp blow, been dropped or otherwise damaged in any way. Have a qualified technician examine the charger and repair it if necessary. Do not disassemble the charger.

Do NOT charge the batteries when the work area or the battery temperature is at or below 5° C (41° F) or above 40.5° C (105° F).

Unplug the charger when not in use and before cleaning or maintenance.

BATTERY PACK RECYCLING











To preserve our natural resources, please recycle or dispose of batteries properly.

The batteries charged by this charger may contain chemicals and metals that are harmful to the environment. Never dispose of re-chargeable batteries in your normal household garbage or in landfill sites as they will add to the pollution of the environment.



SYMBOLS

⚠️ WARNING: Some of the following symbols may appear on the drill. Study these symbols and learn their meaning. Proper interpretation of these symbols will allow for more efficient and safer operation of this tool.

V	Volts		Three-phase alternating current
A	Amperes		Three-phase alternating current with neutral
Hz	Hertz		direct current
W	Watts	n_0	No load speed
kW	Kilowatts		Alternating or direct current
μF	Microfarads		Class II Construction
L	Liters		Splash-proof construction
kg	Kilograms		Watertight construction
H	Hours		Protective grounding at terminal, Class I tools
N/cm ²	Newtons per square centimetre	.../min	Revolutions or reciprocations per minute
Pa	Pascals	\emptyset	Diameter
OPM	Oscillation per minute	0	Off position
Min	Minutes		Directional Arrow
S	Seconds		Warning symbol
~ or AC	Alternating current		Wear safety glasses, hearing protection and dust mask



JD6318H20

This symbol designates that this tool is listed with U.S. and Canadian requirements by cTUVus Testing Laboratories, Inc. UL62841-1, UL62841-2-1 CSA C22.2#UL62841-1, UL62841-2-1

KNOW YOUR CORDLESS 20V MAX 2VSR DRILL



Battery Charger
5350-010



ASSEMBLY AND OPERATING

CHECKING THE BATTERY CHARGE STATUS

The level of charge remaining in the battery can be checked by using the battery LED power indicator that is contained on the end of the battery.

NOTE: The battery charge remaining may be checked while the battery is installed in the tool with the ON/OFF switch turned OFF. It may also be checked while the battery is removed from the tool. DO NOT check the battery charge remaining while the battery is in the charger.

NOTE: The battery charge remaining may be checked while the battery is installed in the tool with the ON/OFF switch turned OFF. It may also be checked while the battery is removed from the tool. DO NOT check the battery charge remaining while the battery is in the charger.



You will get a false reading and you may also damage the battery status system.

1. Press and hold the battery status button located on the end of the battery.
2. One or more of the Four LED lights in the LED window will come ON to indicate the amount of charge that is remaining in the battery as follows:

Charge level indicator				
Amount of charge remaining	10-25%	25-50%	50-75%	75-100%

3. Release the battery status button to turn the LED's OFF.

CHARGING THE BATTERY PACK

1. Place the battery charger (1) in a dry location near a 110–120V 60 Hz electrical outlet (Fig. 1).
2. Plug the battery charger into the outlet and make sure the green LED indicator light (5) comes ON. If it does not, refer to the chart (Fig. 2) to identify the problem.
3. Turn the battery (2) upside down and slide it onto the charger.



Fig. 1

NOTE: Make sure the grooves (3) in the sides of the battery slide over the matching tabs on the charger (4) until the battery latch “clicks” into place.

NOTES:

- a) When the charger is plugged into the wall receptacle and NO battery is on the charger, the green indicator light (5) will turn ON indicating the charger is “live”.
- b) When a discharged battery is installed on the charger, the green indicator light will turn OFF and the red indicator light (6) will FLASH. The flashing red indicator light indicates the battery is being charged.
- c) If the red indicator light does not come ON, check to make sure battery pack is slid fully onto the charger and the electrical outlet is working properly.
- d) See Fig. 2 at right for other indicator light functions.
- e) A discharged battery pack should be fully charged in up to 75 minutes.
- f) It is normal for the battery charger to hum and be warm to the touch during operation.
- g) If the battery pack does not charge properly, check to make sure the electrical outlet is “live”.
- h) Do NOT charge batteries when the work area or the battery temperature is at or below 5°C (41° F) or above 40°C (105° F).

GREEN LIGHT	RED LIGHT	BATTERY INSERTED INTO CHARGER	CHARGING STATUS
ON	OFF	NO	Charger connected to power supply
OFF	Blink	YES	Battery being charged
ON	OFF	YES	Battery fully charged
OFF	ON	YES	Battery is charged but not operational on tool. This may indicate defective / bad contact on battery.
ON	ON	YES	Charging conditions are either too hot or too cold

Fig. 2

INSTALLING A BATTERY ON THE DRILL

1. Remove the discharged battery (1) from the drill by pressing downward on the battery release button (2) and sliding the battery backward until it is removed from the drill handle (3) (Fig. 3).
2. Slide the fully charged battery onto the matching keys (4) in the drill handle where the discharged battery has been removed.

NOTE: Make sure the slots in the battery are fully engaged with the mounting keys in the drill handle. The battery release button will “click” into place when the battery is fully installed.

⚠ WARNING: Do not immerse the battery pack in water. Sudden cooling could cause a hot battery to explode or leak.

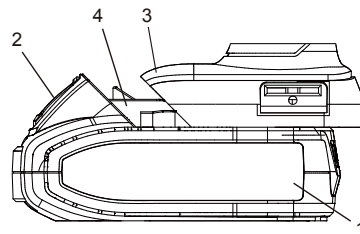



Fig. 3

ADJUSTING THE TORQUE

Your drill is equipped with an adjustable torque clutch for driving different types of screws into different types of materials. It also has a setting for "drilling". The proper setting depends upon the type of material, the size of screw being used, and the function required.

Adjust the torque setting as follows:

1. Identify the torque settings located on the torque adjustment ring (1) (Fig. 4).
2. Rotate adjustment ring to align the correct torque setting number with the torque indicator arrow (2). See the chart below for the correct torque settings.
 - 1–4 For driving small screws.
 - 5–7 For driving medium sized screws into soft materials.
 - 8–10 For driving screws into soft & medium-density materials.
 - 11–13 For driving screws into hardwood.
 - 14–16 For driving large screws.
 -  For drilling. This position is marked with a drill bit icon (3) on the torque adjustment ring (Fig. 5).

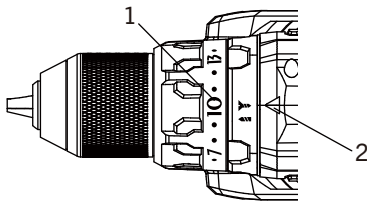

Fig. 4

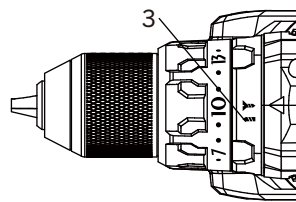

Fig. 5

FORWARD/REVERSE SWITCH

The forward/reverse switch (1) is conveniently mounted above the trigger switch (2) (Fig. 6). To make the drill rotate clockwise (for drilling) push the forward/reverse switch to the left. To make the drill rotate counter clockwise for removing screws, push the forward/reverse switch to the right.

NOTES:

- Never change the position of the forward/reverse switch while the chuck is turning.
- The trigger switch will NOT function with the forward/reverse switch in the middle position.

VARIABLE-SPEED TRIGGER SWITCH

This drill is equipped with a variable-speed ON/OFF trigger switch.

1. To start drill, gently squeeze the trigger switch (2) (Fig. 7).

NOTE: The drill will turn at its slowest speed when the trigger switch is depressed slightly. The drill will turn at its fastest speed when the trigger switch is fully depressed.

2. To stop the drill, release the trigger switch.

NOTE: Drilling at a slow speed for an extended period of time may cause the drill motor or the battery pack to overheat. If either the drill or the battery gets hot, stop drilling and allow them to cool for at least 15 minutes.

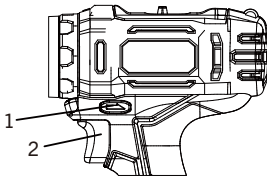

Fig. 6

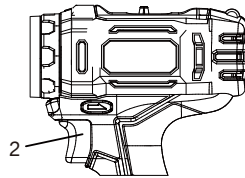

Fig. 7

LED WORK LIGHT

The LED work light (3) will automatically turn ON when the trigger switch is squeezed (Fig. 8). It will automatically turn OFF when the trigger switch is released.

NOTE: The LED light has a 10 second time delay.

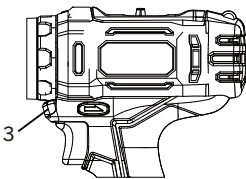

Fig. 8

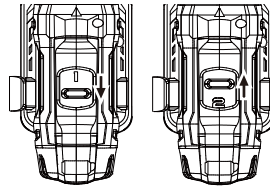

Fig. 9a Fig. 9b

TWO-SPEED GEAR BOX SWITCH

The two-speed gear box switch is located on the top of the drill housing. Set the speed-control switch to the desired speed before starting the drill. Slide the speed-control switch FORWARD.

(Fig. 9a) for low-speed operation. Slide the speed control-switch BACK (Fig. 9b) for high-speed operation.

NOTES:

- Use low-speed setting for drilling large holes and for driving screws.
- Use high-speed setting for drilling smaller holes.
- Do NOT change the speed-control switch position while drill is turned ON. Damage to the gears may result.

INSTALLING DRILL BITS

⚠ WARNING: Never hold the chuck body with one hand and use the drill power to rotate the drill body to loosen or tighten bits. Serious injury may result.

This drill is equipped with a double sleeve keyless chuck.

1. To open the keyless drill chuck, grasp and hold the chuck collar (1) with one hand (Fig. 10). Rotate the chuck body (2) with the other hand in a counterclockwise direction (3) until the chuck jaws (4) open wide enough to accept the bit (5).
2. Insert the bit into the chuck the full length of the jaws. Raise the front of your drill slightly to prevent the bit from falling out of the chuck jaws.
3. Tighten the chuck jaws onto the bit by turning the chuck body in a clockwise direction. **NOTE:** Make sure the bit is properly aligned in the jaws and NOT at an angle. An improperly aligned bit could be thrown from the chuck when drill is started. Make sure flat sides of the screwdriver bit are being grasped by the chuck jaws.
4. Finish tightening the chuck jaws by holding the chuck collar with one hand and firmly tightening the chuck body by rotating it in a clockwise direction.

NOTE: Hand tighten the chuck jaws. Do NOT use pliers. You will damage the chuck.

⚠ WARNING: Do not insert the drill bit into the chuck and tighten as shown in Fig. 11. The drill bit MUST be properly inserted with all three of the chuck jaws holding the bit centered in the chuck. Failure to properly insert the drill bit could cause the drill bit to be thrown from the chuck, resulting in possible serious injury or damage to the chuck.

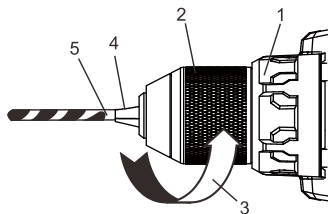

Fig. 10

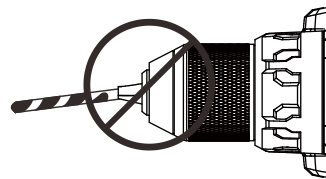

Fig. 11

REMOVING BITS

1. To open the keyless drill chuck, grasp and hold the chuck body and rotate it in a counterclockwise direction until the chuck jaws open wide enough to release the bit.
2. Remove the drill bit.

⚠️ WARNING: For safety reasons, the operator must read the sections of this Owner's Manual entitled "GENERAL SAFETY WARNINGS", "POWER TOOL SAFETY", "SPECIFIC SAFETY RULES", "BATTERY & CHARGER SAFETY" and "SYMBOLS" before using this cordless drill.

Verify the following every time the cordless drill is used:

1. Safety glasses, safety goggles, or face shield is being worn.
2. Hearing protection is being worn.
3. The chuck has not worked loose on the spindle.
4. The bit is in good condition and is properly tightened onto the chuck.

Failure to observe these safety rules will significantly increase the risk of injury.

DRILLING

When drilling into smooth, hard surfaces such as metal, use a center punch to mark the desired hole location. This will prevent the drill bit from slipping off center as the hole is started.

The workpiece to be drilled should be secured in a vice or with clamps to keep it from turning as the drill bit rotates (Fig. 12).

1. Check the drill bit to make sure it is firmly locked into the drill chuck and verify that the forward/reverse switch is in the forward position.
2. Set the torque clutch to the drilling position.
3. Hold the drill firmly with both hands whenever possible. Use one hand to grasp the handle and switch.

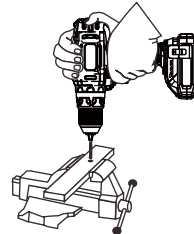

Fig. 12

NOTE: Make sure the hand placed on the body of the drill does not cover the air vents. Covering these air vents will reduce motor cooling, and possibly lead to overheating the motor.

4. While holding the drill firmly, place the point of the drill bit at the point to be drilled. Squeeze the switch trigger to start the drill.

NOTES: Always use a higher drill speed when drilling small holes. Use a slower drill speed when drilling large holes.

5. Move the drill bit into the workpiece applying only enough pressure to keep the bit cutting. Do not force the drill bit or apply sideways pressure to elongate the hole.

⚠️ WARNING: Be prepared for binding and bit breakthrough. When these situations occur, the drill bit has a tendency to grab the workpiece. This action will kick the drill opposite to the direction of the drill bit rotation and could cause loss of control when breaking through material as you complete drilling the hole. If you are not prepared, this loss of control can result in serious injury.

When drilling metals, use light oil on the drill bit to keep it from overheating. The oil will prolong the life of the drill bit and improve the cutting action. If the bit jams in the workpiece, or if the drill stalls, release the trigger switch immediately. Remove the bit from the workpiece and determine the reason for jamming.

DRIVING SCREWS

When driving screws, care must be taken to use the bit that correctly fits the screw being driven. Make sure you use the largest bit size that will properly fit into the head of the screw.

1. Select the correct screwdriver bit for the screw being driven.
2. Fasten the screwdriver bit into the chuck, making sure the flat sides of the bit are gripped by the chuck jaws.
3. Set the torque clutch to the appropriate setting, based on the chart on Page 12.

NOTE: If the workpiece material is particularly soft or porous, set the torque clutch to a lower setting to avoid overdriving the screw.

4. If the screw is driven too far into the workpiece before the clutch releases, set the clutch to a lower setting, and do not pull the trigger switch fully back. If the screw is not driven far enough into the workpiece, set the clutch to a higher setting.

NOTE: Do not continue to drive the screw once the clutch has released. This causes unnecessary wear of the clutch.

REMOVING THE CHUCK

1. Remove the battery pack from the drill.
2. Insert a 5/16" (8 mm) or larger hex key (1) into the chuck (2) and tighten the chuck jaws securely (Fig. 13). Make sure each of the chuck jaws (3) is seated on the flat surfaces of the hex key.
3. Tap the hex key sharply with a mallet (4) in a CLOCKWISE direction. This action will loosen the screw in the chuck for easy removal.
4. Open chuck jaws and remove the hex key.
5. Open the chuck jaws as far as possible.
6. Remove the chuck screw using a #2 \oplus screwdriver (Fig. 14). NOTE: Turn the screw CLOCKWISE to remove it. This screw has a left-handed thread.
7. Insert the hex key into the chuck and tighten jaws of chuck securely (Fig. 15). Tap the hex key sharply with a mallet in a COUNTER-CLOCKWISE direction. This will loosen the chuck on the spindle. The chuck can now be unscrewed and removed from the spindle by hand.

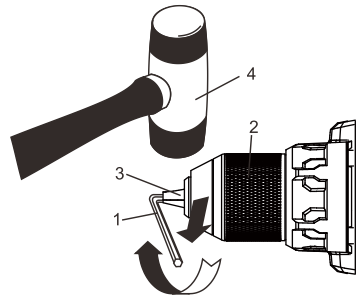

Fig. 13

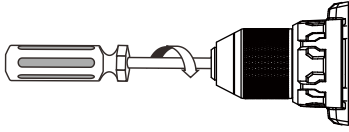

Fig. 14

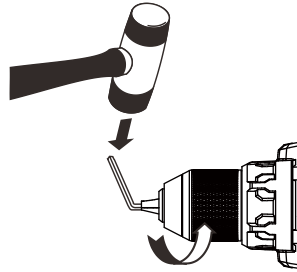

Fig. 15

RETIGHTENING A LOOSE CHUCK

1. Remove the battery pack from the drill.
2. Insert a 5/16" (8 mm) or larger hex key (1) into the chuck (2) and tighten the chuck jaws securely (Fig. 16). Make sure each of the chuck jaws (3) is seated on the flat surfaces of the hex key.
3. Tap the hex key sharply with a mallet (4) in a CLOCKWISE direction. This action will loosen the screw in the chuck for easy removal.
4. Open the chuck jaws and remove the hex key.
5. Tighten the chuck screw using a #2 \oplus screwdriver (Fig 14).

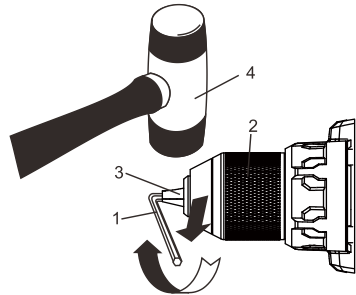

Fig. 16

NOTE: Turn the screw COUNTER-CLOCKWISE to tighten it. This screw has a left-handed thread.

MAINTENANCE

GENERAL

⚠️ WARNING: When servicing, use only identical replacement parts. The use of any other part may create a hazard or cause product damage.

DO NOT use solvents when cleaning plastic parts. Plastics are susceptible to damage from various types of commercial solvents and may be damaged by their use. Use a clean cloth to remove dirt, dust, oil, grease etc.

⚠️ WARNING: Do not allow brake fluids, gasoline, petroleum-based products, penetrating oils, etc. to come into contact with plastic parts. They contain chemicals that can damage, weaken, or destroy plastic.

DO NOT abuse power tools. Abusive practices can damage the tool and the workpiece.

⚠️ WARNING: DO NOT attempt to modify tools or create accessories. Any such alteration or modification is misuse and could result in a hazardous condition leading to possible serious injury. It will also void the warranty.

LUBRICATION

All of the bearings in this tool are lubricated with a sufficient amount of high-grade lubricant for the life of the unit under normal conditions. Therefore, no further lubrication is required.

BATTERY PACK REMOVAL AND PREPARATION FOR RECYCLING

To preserve our natural resources, please recycle or dispose of batteries properly.

The batteries accompanying this tool may contain chemicals and metals that are harmful to the environment. Never dispose of rechargeable batteries in your normal household garbage or in landfill sites because they will add to the pollution of the environment.

Consult your local waste authority for information regarding available recycling and disposal options.

⚠️ WARNING: Upon removal of the battery pack, cover the terminals of the battery pack with electrical tape or heavy-duty adhesive tape. Never touch both terminals with metal objects or body parts because a short circuit may result. Keep away from children. Do not attempt to destroy or disassemble battery pack or remove any of its components. Rechargeable batteries must be recycled or disposed of properly. Failure to comply with these warnings could result in fire and serious injury.

EXPLODED VIEW

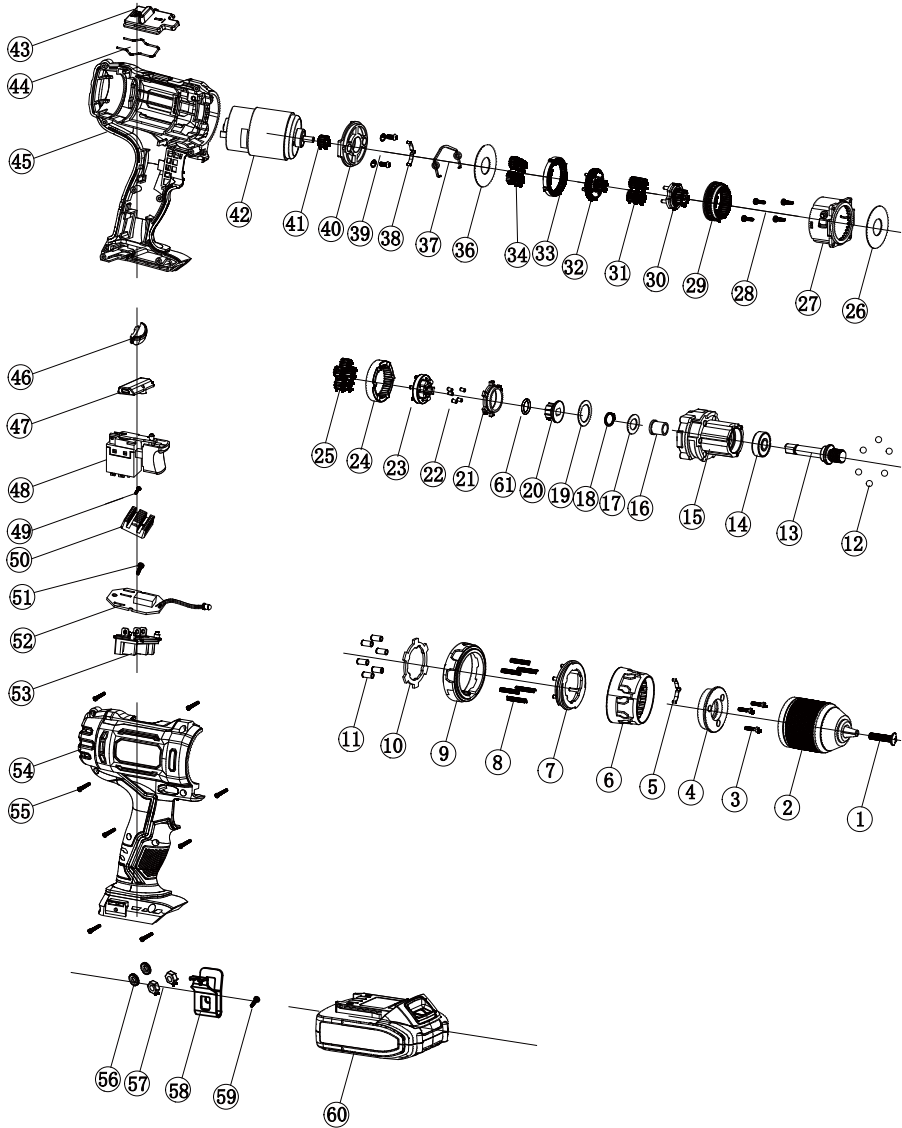

PARTS LIST

⚠ WARNING When servicing, use only original equipment replacement parts. The use of any other parts may create a safety hazard or cause damage to the tool. Any attempt to repair or replace electrical parts on this tool may create a safety hazard unless repairs are performed by a qualified technician. For more information, call the Toll-free Helpline, at 1-866-349-8665.

Always order by PART NUMBER, not by key number.

Key #	Part #	Part Name	Quantity
1	4020030020	Screw M6X18	1
2	1140050025	Chuck	1
3	4030010253	Screw ST2.9X14	3
4	2020210015	Plate	1
5	2050070071	Spring	1
6	3120080142	Collar clutch	1
7	3150190211	Ring	1
8	2050080150	Spring	6
9	3150190214	Ring	1
10	2030020383	Washer	1
11	4110040016	Needle $\phi 5 \times 11$	6
12	4080060001	Ball $\phi 5$	6
13	2040050174	Shaft	1
14	4010010038	Bearing 609 2Z	1
15	3150070108	Gear box	1
16	2010080127	Shaft coat	1
17	2030020101	Washer $\phi 14.8 \times \phi 9.2 T0.5$	1
18	4100020024	Washer 9	1
19	2030020214	Washer $\phi 25 \times \phi 17 T0.5$	1
20	2010230012	Driven plate	1
21	2010240034	Fixing ring	1
22	4110020003	Needle $\phi 3 \times 4.8$	6
23	1170070098	Planet assembly 3	1
24	2010090086	Ring	1
25	2010010139	Planet gear	5
26	2030020023	Washer $\phi 40 \times \phi 18 T0.5$	1
27	3150080024	Gear box	1
28	4030010003	Screw ST2.9X12	4
29	2010090085	Ring	1

Key #	Part #	Part Name	Quantity
30	1170070097	Planet assembly 2	1
31	2010010109	Planet gear	4
32	1170070096	Planet assembly 1	1
33	2010090071	Ring	1
34	2010010108	First planetary gear	4
35			
36	2030020242	Washer $\varnothing 38 \times \varnothing 15 T 0.5$	1
37	2050080180	Speed hook	1
38	2050070071	Spring	1
39	4020010143	Screw M4*8 with washer	2
40	3150090059	Flange	1
41	2010180057	Motor gear	1
42	1030070032	Motor	1
43	3120120147	Speed control board	1
44	2050080208	Wire	1
45	3010010201	Housing I	1
46	3160060105	Led cover	1
47	3120030144	Forward and reverse button	1
48	1060050017	Switch	1
49	4020010027	Screw M3*6	1
50	2020180023	Cooling block	1
51	4030010023	Screw M3*8	1
52	1130030101	PCB	1
53	3150170023	Electrode plate	1
54	3010010201	Housing II	1
55	4030010253	Screw ST2.9X14	8
56	4040080003	Washer	2
57	4060010039	Nut M3	2
58	2030100069	Hook	1
59	4020010168	Screw M3*12	1
60	1290090020	Battery	1

WARRANTY

BENCHMARK 20V MAX 2VSR DRILL WARRANTY

If this Benchmark tool fails due to a defect in material or workmanship within five years from the date of purchase, return it to any Home Hardware store with the original bill of sale for exchange. 3-year warranty for the battery and charger. This warranty does not include expendable parts including but not limited to blades, brushes, belts, light bulbs.

This warranty covers defects in material or workmanship only. It does not cover normal wear and tear, failure due to abuse/misuse, or defects caused by careless or accidental mishandling. If this Benchmark product is used for commercial or rental purposes, this warranty does not apply.

20V MAX 1/2" DRILL



5 year limited warranty on tool
3 year limited warranty on battery and charger

BENCHMARKTM_{MC}

BENCHMARK TOOLS CANADA
ST. JACOBS, ONTARIO N0B 2N0

© 2021 Home Hardware Stores Limited

CUSTOMER SERVICE/TECH SUPPORT

1-866-349-8665

1239-104

Made in China



* This BenchmarkTM product carries a five (5) year LIMITED warranty against defects in workmanship and materials. The charger and batteries carry a three (3) year LIMITED warranty. See Owner's Manual for full details.



JD6318H20

**READ ALL INSTRUCTIONS BEFORE FIRST USE.
KEEP THIS MANUAL FOR FUTURE REFERENCE.
KEEP AWAY FROM CHILDREN.**

Maximum initial battery voltage (measured without a load)
is 20 volts. Nominal voltage is 18 volts.



**WEAR CSA APPROVED
EYE PROTECTION**



**WEAR EAR
PROTECTION**



**WEAR A
FACE MASK**

BENCHMARKTM MC

20V MAX IMPACT DRIVER



5 Year Limited Warranty
3 Year Limited Warranty on Battery and Charger
Battery & charger included where applicable



JD509920

**READ ALL INSTRUCTIONS BEFORE FIRST USE.
KEEP THIS MANUAL FOR FUTURE REFERENCE.
KEEP AWAY FROM CHILDREN.**

Maximum initial battery voltage (measured without a load)
is 20 volts. Nominal voltage is 18 volts.



**WEAR CSA APPROVED
EYE PROTECTION**



**WEAR EAR
PROTECTION**



**WEAR A
FACE MASK**

PRODUCT SPECIFICATIONS

20V MAX IMPACT DRIVER	
Variable Speed	0–3,000 RPM (no load)
Impact Speed	0–3,000 BPM
Torque	1,800 in/lbs (203 Nm) maximum
Hex drive	Quick release 1/4" (6.35 mm)
Weight	3.5lbs (1.16kg)
Battery	20V 2.5Ah Max* Li-ion (Maximum charged battery voltage, measured without load, is 20V with a nominal value of 18V)
Replacement Battery	5350-023 (2.5Ah)
Replacement Charger Assembly	5350-010 (2.4A) up to 75minutes charge time

NEED ASSISTANCE?

Call us on our toll-free customer support line:
1-866-349-8665 (Monday through Friday 9am – 5pm Eastern Standard Time)

- Technical questions
- Replacement parts
- Parts missing from package

TABLE OF CONTENTS

Product Specifications 1

Table of Contents 2

General Safety Instructions 3

Eye, Ear & Lung Protection 3

Electrical Safety 4

Power Tool Safety 4

Work Area Safety 4

Electrical Safety 4

Personal Safety 5

Power Tool Use and Care 5

Battery Tool Use and Care 6

Service 6

Specific Safety Rules 6

Battery & Charger Safety 8

Battery Pack Recycling 9

Symbols 10

Know Your 20V Max Impact Driver..... 11

Assembly and Operation 12

Checking the Battery Charge Status 12

Checking the Battery Pack 12

Installing a Battery in the Impact Driver..... 13

Installing Screwdriver Bits and Sockets 14

Forward/Reverse Switch..... 15

Variable-Speed Trigger Switch..... 15

LED Work Light 16

Preparing Screw Holes 16

Driving Screws..... 17

Installing Nut Drivers For 3/16" To 3/8" Nuts 18

Installing Impact Sockets For 7/16" to 3/4" Nuts 18

Removing Nuts 18-19

Maintenance 20

General 20

Lubrication 20

Lithium-ion Battery Performance 20

Lithium-ion Battery Maintenance 20

Battery Pack Removal and Preparation for Recycling..... 21

Exploded View 22





Parts List 23

Warranty 24

GENERAL SAFETY INSTRUCTIONS

⚠️ WARNING: Before using this tool or any of its accessories, read this manual and follow all Safety Rules and Operating Instructions. The important precautions, safeguards and instructions appearing in this manual are not meant to cover all possible situations. It must be understood that common sense and caution are factors which cannot be built into the product.

EYE, EAR & LUNG PROTECTION

SYMBOL	MEANING
<p data-bbox="114 511 288 544">⚠️ DANGER</p> 	<p data-bbox="317 519 946 565">ALWAYS WEAR EYE PROTECTION THAT CONFORMS WITH CSA Z94.3 or ANSI SAFETY STANDARD Z87.1</p> <p data-bbox="317 565 920 690">FLYING DEBRIS can cause permanent eye damage. Prescription eyeglasses ARE NOT a replacement for proper eye protection. The usage of a safety standard compliant face shield placed over proper safety glasses or goggles can reduce the risk of facial injury. Non-compliant eyewear can cause serious injury if broken during the operation of a power tool.</p>
<p data-bbox="114 722 288 755">⚠️ WARNING</p> 	<p data-bbox="317 755 909 795">Use hearing protection, particularly during extended periods of operation of the tool, or if the operation is noisy.</p>
<p data-bbox="114 852 288 885">⚠️ WARNING</p> 	<p data-bbox="317 852 734 909">WEAR A DUST MASK THAT IS DESIGNED TO BE USED WHEN OPERATING A POWER TOOL IN A DUSTY ENVIRONMENT.</p> <p data-bbox="317 917 920 974">Dust that is created by power sanding, sawing, grinding, drilling, and other construction activities may contain chemicals that are known to cause cancer, birth defects,</p> <p data-bbox="317 982 776 998">or other genetic abnormalities. These chemicals include:</p> <ul data-bbox="317 998 776 1079" style="list-style-type: none"> • Lead from lead-based paints • Crystalline silica from bricks, cement, and other masonry products • Arsenic and chromium from chemically treated lumber <p data-bbox="317 1088 952 1209">The level of risk from exposure to these chemicals varies, according to how often this type of work is performed. In order to reduce exposure to these chemicals, work in a well-ventilated area, and use approved safety equipment, such as a dust mask that is specifically designed to filter out microscopic particles.</p>
<p data-bbox="114 1242 288 1274">⚠️ WARNING</p> 	<p data-bbox="317 1226 808 1299">TO AVOID ELECTRICAL HAZARDS, FIRE HAZARDS OR DAMAGE TO THE TOOL, USE PROPER CIRCUIT PROTECTION.</p> <p data-bbox="317 1307 952 1388">This tool is wired at the factory for 120 V AC operation. It must be connected to a 120 V AC, 15 A circuit that is protected by a time-delayed fuse or circuit breaker. To avoid shock or fire, replace power cord immediately if it is worn, cut or damaged in any way.</p>

⚠ WARNING

WARNING: Ventilation openings in batteries and chargers must always be open to allow cooling air to circulate freely. Air vents that are blocked, restricted or covered may result in the battery or charger overheating. Overheating may lead to damage to the tool or cause a fire, resulting in possible serious injury.

POWER TOOL SAFETY

⚠ WARNING: Read all safety warnings and instructions. Failure to follow the warnings and instructions may result in electric shock, fire and/or serious injury.

Save all warnings and instructions for future reference.

WORK AREA SAFETY

Keep work area clean and well lit. Cluttered or dark areas invite accidents.

Do not operate power tools in explosive atmospheres, such as in the presence of flammable liquids, gases or dust. Power tools create sparks which may ignite the dust or fumes.

Keep children and bystanders away while operating a power tool. Distractions can cause you to lose control.

ELECTRICAL SAFETY

Power tool plugs must match the outlet. Never modify the plug in any way.

Do not use any adapter plugs with earthed (grounded) power tools. Unmodified plugs and matching outlets will reduce risk of electric shock.

Avoid body contact with earthed or grounded surfaces such as pipes, radiators, ranges and refrigerators. There is an increased risk of electric shock if your body is earthed or grounded.

Do not expose power tools to rain or wet conditions. Water entering a power tool will increase the risk of electric shock.

Do not abuse the cord. Never use the cord for carrying, pulling or unplugging the power tool. Keep cord away from heat, oil, sharp edges or moving parts. Damaged or entangled cords increase the risk of electric shock.

When operating a power tool outdoors, use an extension cord suitable for outdoor use. Use of a cord suitable for outdoor use reduces the risk of electric shock.

If operating a power tool in a damp location is unavoidable, use a residual current device (RCD) protected supply. Use of a ground fault circuit interrupter (GFCI) reduces the risk of electric shock.

PERSONAL SAFETY

Stay alert, watch what you are doing and use common sense when operating a power tool. Do not use a power tool while you are tired or under the influence of drugs, alcohol or medication. A moment of inattention while operating power tools may result in serious personal injury.

Use personal protective equipment. Always wear eye protection. Protective equipment such as dust mask, non-skid safety shoes, hard hat, or hearing protection used for appropriate conditions will reduce personal injuries.

Prevent unintentional starting. Ensure the switch is in the off-position before connecting to power source and/or battery pack, picking up or carrying the tool. Carrying power tools with your finger on the switch or energizing power tools that have the switch on invites accidents.

Remove any adjusting key or wrench before turning the power tool on.

A wrench or a key left attached to a rotating part of the power tool may result in personal injury.

Do not overreach. Keep proper footing and balance at all times. This enables better control of the power tool in unexpected situations.

Dress properly. Do not wear loose clothing or jewellery. Keep your hair, clothing and gloves away from moving parts. Loose clothes, jewellery or long hair can be caught in moving parts.

If devices are provided for the connection of dust extraction and collection facilities, ensure these are connected and properly used. Use of dust collection can reduce dust-related hazards.

POWER TOOL USE AND CARE

Do not force the power tool. Use the correct power tool for your application.

The correct power tool will do the job better and safer at the rate for which it was designed.

Do not use the power tool if the switch does not turn it on and off. Any power tool that cannot be controlled with the switch is dangerous and must be repaired.

Disconnect the plug from the power source and/or the battery pack from the power tool before making any adjustments, changing accessories, or storing power tools. Such preventive safety measures reduce the risk of starting the power tool accidentally.

Store idle power tools out of the reach of children and do not allow persons unfamiliar with the power tool or these instructions to operate the power tool.

Power tools are dangerous in the hands of untrained users.

Maintain power tools. Check for misalignment or binding of moving parts, breakage of parts and any other condition that may affect the power tool's operation. If damaged, have the power tool repaired before use. Many accidents are caused by poorly maintained power tools.

Keep cutting tools sharp and clean. Properly maintained cutting tools with sharp cutting edges are less likely to bind and are easier to control.

Use the power tool, accessories and tool bits etc. in accordance with these instructions, taking into account the working conditions and the work to be performed. Use of the power tool for operations different from those intended could result in a hazardous situation.

Hold power tool by insulated gripping surfaces when performing an operation where the cutting tool may contact hidden wiring or its own cord. Contact with a "live" wire will make exposed metal parts of the tool "live" and shock the operator.

Hold power tool by insulated gripping surfaces, when performing an operation where the fastener may contact hidden wiring or its own cord.

Fasteners contacting a “live” wire may make exposed metal parts of the power tool “live” and could give the operator an electric shock.

BATTERY TOOL USE AND CARE

Recharge only with the charger specified by the manufacturer. A charger that is suitable for one type of battery pack may create a risk of fire when used with another battery pack.

Use power tools only with specifically designated battery packs. Use of any other battery packs may create a risk of injury and fire.

When battery pack is not in use, keep it away from metal objects like paper clips, coins, keys, nails, screws, or other small metal objects that can make a connection from one terminal to another. Shorting the battery terminals together may cause burns or fire.

Under abusive conditions, liquids may be ejected from the battery; avoid contact. If contact accidentally occurs, flush with water. If liquid contacts eyes, additionally seek medical help. Liquid ejected from the battery may cause irritation or burns.

SERVICE

Have your power tool serviced by a qualified repair person using only identical replacement parts. This will ensure that the safety of the power tool is maintained.

SPECIFIC SAFETY RULES

 WARNING: Know your cordless impact driver. Do not plug in the charger or install the battery in the tool until you have read and understand this Instruction Manual. Learn the tool’s applications and limitations, as well as the specific potential hazards related to this tool. Following this rule will reduce the risk of electric shock, fire, or serious injury.



Always wear eye protection. Any power tool can throw foreign objects into your eyes and cause permanent eye damage. ALWAYS wear safety goggles (not glasses) that comply with ANSI safety standard Z87.1. Everyday glasses have only impact resistant lenses. They ARE NOT safety glasses.

 WARNING: Glasses or goggles not in compliance with ANSI Z87.1 could cause serious injury when they break.

 WARNING: Always use a safety shield, hearing protection and dust mask when drilling concrete.

 WARNING: To avoid fire or toxic reaction, never use gasoline, naphtha, acetone, lacquer thinner or similar highly volatile solvents to clean the tool.

 WARNING: Use only accessories that are recommended for this cordless drill. Follow the instructions that accompany the accessories. The use of improper accessories may result in injury to the operator or damage to the tool.

⚠️ WARNING: If any part is missing or damaged, do not plug the tool into the power source or install any accessory until the missing or damaged part is replaced.

Use impact sockets and accessories that are designed for use with an impact driver. Do not use chrome plated sockets and accessories. Chrome plated sockets and accessories are designed for hand use only and **MUST NOT** be used with an impact driver. They may shatter and possibly cause serious injury.

Before each use, check the impact sockets and accessories for excessive wear or cracks. Worn or damaged sockets or accessories may shatter and possibly cause serious injury. Worn accessories may allow the socket to come off during operation of the impact driver.

After installing any accessory in the hex drive, pull outward on the accessory to ensure it is properly installed and cannot be pulled out of the hex drive.

Never use the impact driver as a torque wrench. Always use a torque wrench to adjust the fastener to the specified torque.

Keep the impact driver handle and body clean and free of oil and grease. Always use a clean dry cloth when cleaning. Do not use solvents, brake fluid, gasoline or other petroleum products to clean the tool. They will damage the tool.

Do not wear neckties or loose clothing.

When wearing gloves, they must be tight fitting and slip resistant type. Leather gloves offer the best protection.

Always use two hands when operating the impact driver. Use one hand on the handle and the other on the front of the tool body.

Never place your hand so it is touching the nut driver or accessory when the tool is turned ON. Your hand could be seriously injured.

Always remove the plug from the power source before installing or removing any socket or accessory.

Be ready for components to shift when removing any fastener. The speed of the fastener removal could cause unexpected shifting of the components.

BATTERY & CHARGER SAFETY

⚠️ WARNING: Only use the charger supplied with this kit to charge the 20V Max* Li-ion batteries for this tool. Charging any other batteries may damage the charger and possibly cause serious injury.

Do not store or carry the battery in a manner in which metal objects could contact the exposed metal end. Do not place the battery in aprons, pockets, drawers, etc. with loose nails, screws, keys etc. The battery could short circuit causing a fire, personal injury, or damage to the battery.

Never attempt to open the battery for any reason. If the housing of the battery breaks or cracks, immediately discontinue use and do not recharge.

Do not charge the battery if it is wet or shows any evidence of corrosion.

A small leakage from the battery may occur under extreme usage, charging or temperature conditions. This does not indicate a failure. However, if the outer seal is broken and this leakage gets on your skin, follow these steps:

1. Wash immediately with soap and water.
2. Neutralize with a mild acid such as lemon juice or vinegar.
3. If liquid gets into your eyes, flush immediately with clean water for a minimum of 10 minutes and seek medical attention.

NOTE: The battery liquid is slightly acidic.

Do not incinerate the battery. It can explode in a fire.

Do not use an extension cord. Plug the charger cord directly into an electrical outlet.

Use the charger only in a standard 120V, 60 Hz electrical outlet.

Do not use the charger in wet or damp conditions. It is intended for indoor use only. Do not use the charger near sinks or tubs. Do not immerse the charger in water. Do not allow the cord to hang over the edge of a table or counter or touch hot surfaces.

The charger should be placed away from sinks and hot surfaces.

Do not use the charger to charge any batteries other than the cordless drill batteries. Other batteries may explode.

Do not allow the cord to hang over the edge of a table or counter or touch hot surfaces. The charger should be placed away from sinks and hot surfaces.

Do not operate charger if the cord or plug is damaged. Replace the damaged cord and plug immediately.

Do not operate the charger if it has received a sharp blow, been dropped or otherwise damaged in any way. Have a qualified technician examine the charger and repair it if necessary. Do not disassemble the charger.

Do NOT charge the batteries when the work area or the battery temperature is at or below 0° C (32° F) or above 45° C (113° F).

Unplug the charger when not in use and before cleaning or maintenance.

BATTERY PACK RECYCLING











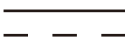



To preserve our natural resources, please recycle or dispose of batteries properly.

The batteries charged by this charger may contain chemicals and metals that are harmful to the environment. Never dispose of re-chargeable batteries in your normal household garbage or in landfill sites as they will add to the pollution of the environment.

SYMBOLS

⚠️ WARNING: Some of the following symbols may appear on the impact driver. Study these symbols and learn their meaning. Proper interpretation of these symbols will allow for more efficient and safer operation of this tool.

V	VOLTS		Three-phase alternating current with neutral
A	Amperes		Direct current
Hz	Hertz	n_0	No load speed
W	Watts		Alternating or direct current
kW	Kilowatts		Class II construction
µF	Microfarads		Splash-proof construction
L	Liters		Watertight construction
kg	Kilograms		Protective grounding at grounding terminal, Class I tools
H	Hours	.../min	Revolutions or reciprocations per minute
N/cm²	Newtons per square centimeter	\emptyset	Diameter
Pa	Pascals	0	Off position
OPM	Oscillations per minute		Arrow
MIN	Minutes		Warning symbol
S	Seconds		Wear your safety glasses
 or ac.	Alternating current		Wear a dust mask
 3	Three-phase alternating current		Wear hearing protection



This symbol designates that this tool is listed with U.S. and Canadian requirements by cTUVus Testing Laboratories, Inc.
 UL62841-1, UL62841-2-2;
 CSA C22.2#62841-1, CSA C22.2#62841-2-2.

KNOW YOUR 20V MAX IMPACT DRIVER

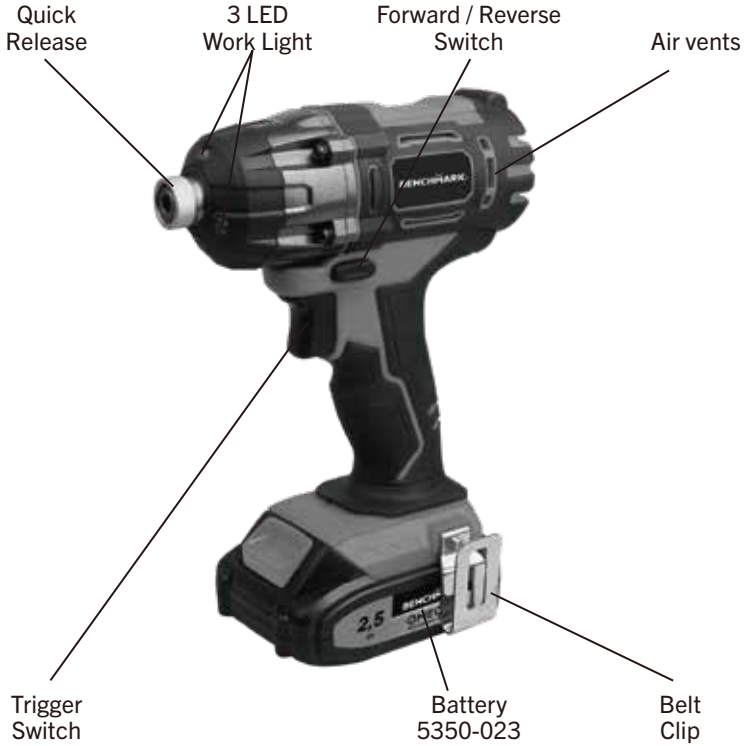

Battery charger
5350-010







ASSEMBLY AND OPERATION

CHECKING THE BATTERY CHARGE STATUS

The level of charge remaining in the battery can be checked by using the battery LED power indicator that is contained on the end of the battery.

NOTE: The battery charge remaining may be checked while the battery is installed in the tool with the ON/OFF switch turned OFF. It may also be checked while the battery is removed from the tool. **DO NOT** check the battery charge remaining while the battery is in the charger. You will get a false reading and you may also damage the battery status system.

1. Press and hold the battery status button located on the end of the battery.
2. One or more of the Four LED lights in the LED window will come ON to indicate the amount of charge that is remaining in the battery as follows:

Charge Level Indicator					
Amount of Charge Remaining	0 - 10%	10 - 25%	25 - 50%	50 - 75%	75 - 100%



3. Release the battery status button to turn the LEDs OFF.

CHECKING THE BATTERY PACK

1. Place the battery charger (1) in a dry location near a 110–120V 60 Hz electrical outlet (Fig. 1).
2. Plug the battery charger into the outlet and make sure the green LED indicator light (5) comes ON. If it does not, refer to the chart (Fig. 2) to identify the problem.
3. Turn the battery (2) upside down and slide it onto the charger. NOTE: Make sure the grooves (3) in the sides of the battery slide over the matching tabs on the charger (4) until the battery latch “clicks” into place.

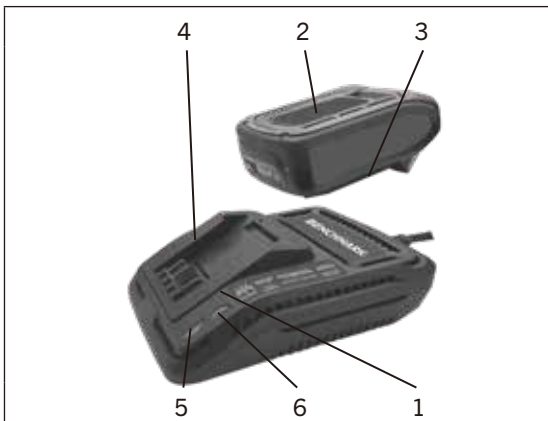

FIG. 1

NOTE: a) When the charger is plugged into the wall receptacle and NO battery is on the charger, the green indicator light (5) will turn ON indicating the charger is “live”.

b) When a discharged battery is installed on the charger, the green indicator light will turn OFF and the red indicator light (6) will FLASH. The flashing red indicator light indicates the battery is being charged.

c) If the red indicator light does not come ON, check to make sure battery pack is slid fully onto the charger and the electrical outlet is working properly.

d) See Fig. 2 at right for other indicator light functions.

e) A discharged battery pack should be fully charged in up to 75 minutes.

f) It is normal for the battery charger to hum and be warm to the touch during operation.

g) If the battery pack does not charge properly, check to make sure the electrical outlet is “live”.

h) Do NOT charge batteries when the work area or the battery temperature is at or below 5°C (41° F) or above 40°C (105° F).

Green Light	Red Light	Battery Inserted Into Charger	Charging Status
ON	OFF	ON	Charger connected to power supply
OFF	Flashing	YES	Battery being charged
ON	OFF	YES	Battery fully charged
OFF	ON	YES	Battery defective or bad contact
ON	ON	YES	Battery too hot or too cold to be charged

FIG. 2

INSTALLING A BATTERY IN THE IMPACT DRIVER

1. Remove the discharged battery (1) from the impact driver by pressing downward on the battery release button (2) and sliding the battery backward until it is removed from the impact driver handle (3) (Fig. 3).
2. Slide the fully charged battery onto the matching keys (4) in the impact driver handle where the discharged battery has been removed.

NOTE: Make sure the slots in the battery are fully engaged with the mounting keys in the impact driver handle. The battery release button will “click” into place when the battery is fully installed.

⚠ WARNING: Do not immerse the battery pack in water. Sudden cooling could cause a hot battery to explode or leak.

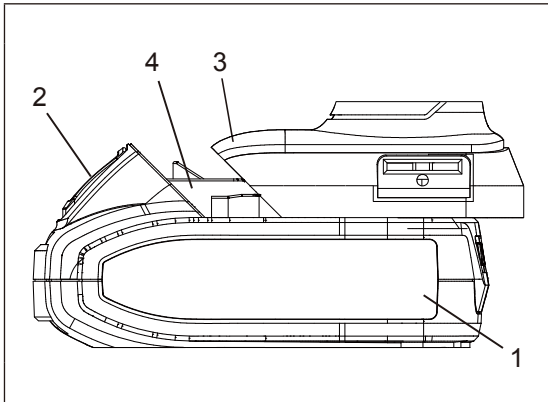

FIG. 3

INSTALLING SCREWDRIVER BITS AND SOCKETS

⚠ WARNING: Never hold the impact driver with your fingers near the switch while changing the screwdriver bits. Accidentally touching the switch may start the tool and possibly cause an injury.

⚠ WARNING: Use only screwdriver bits, sockets that are designed for use with an impact driver. Do not use chrome plated sockets and accessories. Chrome plated sockets and accessories are designed for hand use only and **MUST NOT** be used with an impact driver. They may shatter and possibly cause serious injury.

⚠ WARNING: Always remove the battery from the tool before changing any sockets, bits or accessories. You may injure your hand if the tool is started accidentally.

1. Pull outward on the quick release chuck (1) (Fig. 4).
2. Insert the grooved end of the impact driver bit holder. (2) into the chuck (3) of the tool.

NOTES: a) Always use ANSI single ended screwdriver bits or nut driver with the grooved end. These bits will be properly held in place by the chuck. Other bit types cannot be properly secured in the chuck. b) Push the screwdriver bit as far as it will go into the chuck.

3. Release the quick release chuck.
4. Pull outward on the screwdriver bit to ensure it is properly locked into the chuck.

NOTES: a) Use the largest size screwdriver bit that will properly fit the screw head. b) Make sure the screwdriver bit is in good condition and is neither damaged nor worn.

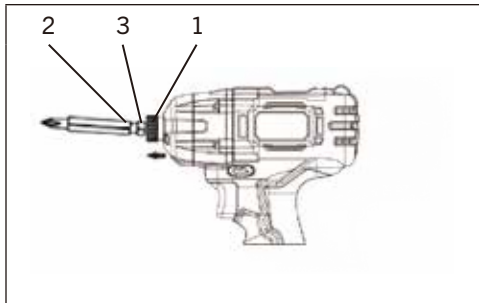

FIG. 4

FORWARD/REVERSE SWITCH

The forward/reverse switch (1) is conveniently mounted above the trigger switch (2) (Fig. 5). To make the impact driver rotate clockwise for driving screws, push the forward/reverse switch to the left. To make the driver rotate counter-clockwise for removing screws, push the forward/reverse switch to the right

NOTE: a) Never change the position of the forward/ reverse switch while the chuck is turning. b) The trigger switch will Not function with the forward/reverse switch in the middle position.

VARIABLE-SPEED TRIGGER SWITCH

This drill is equipped with a variable-speed ON/OFF trigger switch.

1. To start the impact driver, gently squeeze the trigger switch (2) (Fig. 6). **NOTE:** The impact driver will turn at its slowest speed when the trigger switch is squeezed lightly. The impact driver will turn at its fastest speed when the trigger switch is squeezed firmly.

2. To stop the drill, release the trigger switch.

NOTE: Operating the impact driver at a slow speed for an extended period of time may cause the impact driver motor or the battery to overheat. If the driver gets hot, stop operating it and allow it to cool for at least 15 minutes.

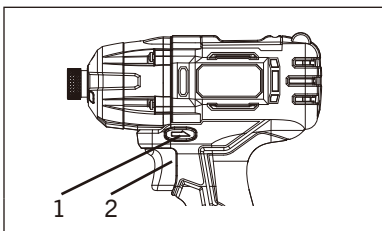

FIG. 5

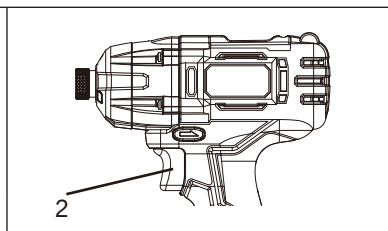
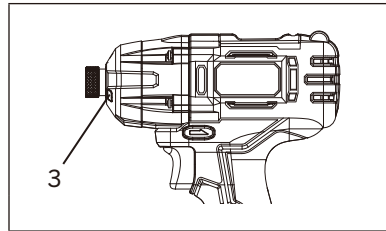

FIG. 6

LED WORK LIGHT

The LED work light (3) will automatically turn ON when the trigger switch is squeezed (Fig. 7). It will automatically turn OFF when the trigger switch is released.

NOTE: The LED light has a 20-second time delay.

**FIG. 7****PREPARING SCREW HOLES**

It is important to prepare screw holes before attempting to fasten two pieces of wood together. Proper preparation will make screws drive easier and prevent misaligned components, stripped screw heads, splitting and separating of wood components.

1. Clamp the components that are to be screwed together in their desired position (Fig. 8).
2. Drill a pilot hole (1) through the outer piece (2) and into the inner piece (3).
Drill hole 2/3 the diameter of the smooth portion of the screw shank.

NOTE: If the wood is soft, drill the hole 2/3 the length of the screw. If the wood is hard, drill the hole the full length of the screw.

3. Remove the clamp from the two pieces to be screwed together.
4. Enlarge the hole (1) in the outer piece (2) so it is the same size as the smooth portion of the screw shank (Fig. 9).
5. If using a flat head screw, counter-sink the hole (4) so the head of the screw will be flush with the surface when fully driven into place.

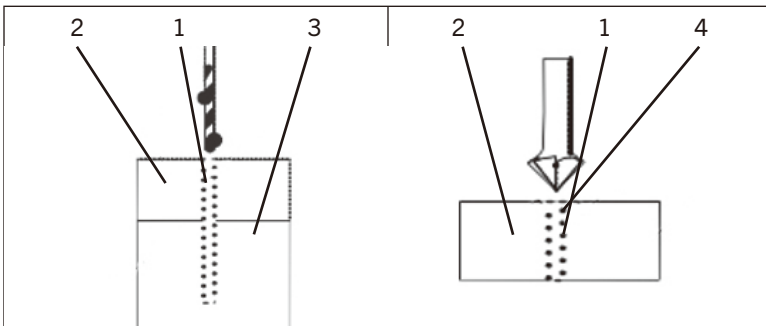
**FIG. 8****FIG. 9**

DRIVING SCREWS

When driving screws, care must be taken to use a bit that correctly fits the head of the screw being driven. Make sure you use the largest bit size that will properly fit into the head of the screw. The bits must also be in good condition and not worn so they will drive screws without slipping out of the screw head.

1. Select the correct screwdriver bit for the screw being driven and install it in the collet (Fig. 4).
2. Set forward/reverse switch to “forward” (Fig. 5).
3. Insert the screwdriver bit fully into the screw head (Fig. 10).
4. While holding the screwdriver bit firmly against the screw and the bit aligned with the screw, squeeze the trigger switch to start the cordless driver and drive the screw.
5. When the screw is driven to the correct depth, release the switch and the impact driver will stop.

NOTE: As the screw is driven into the wood, the torque required to completely drive the screw into the wood will increase. The impact function will allow you to continue driving the screw until it is fully nested in the countersunk area.

6. Release the trigger as soon as the screw is driven to the desired depth. Failure to release the trigger at this point will result in an overdriven screw and possibly twist the head off the screw.

NOTE: To remove screws, follow the same general procedure as for driving screws.

7. Push the forward/reverse button to the RIGHT for removing screws.
8. Insert the bit fully into the screw head.
9. Hold the impact driver and bit firmly against the screw head and squeeze the trigger switch.

NOTE: The impact action will allow you to remove tight screws.

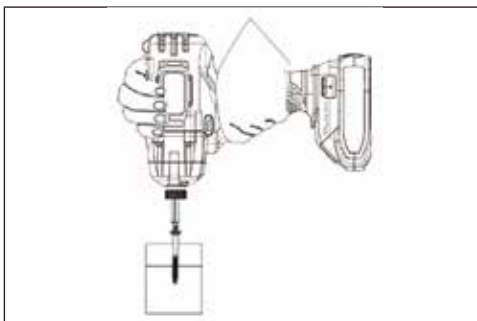

FIG. 10

This impact driver may be used with nut drivers and impact sockets. Although these accessories are NOT included with this tool, they may be purchased separately.

WARNING: Nut drivers, socket adaptor and sockets MUST be impact rated and include the ANSI locking groove.

INSTALLING NUT DRIVERS FOR 3/16" TO 3/8" NUTS

1. Select the correct nut driver size.
2. Insert the hex end (1) into the hex drive (2) (Fig. 11).

NOTE: See Fig. 3 for complete procedure.

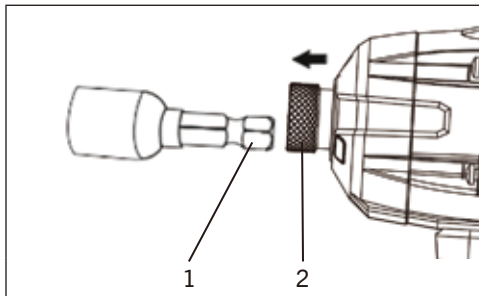

FIG. 11

INSTALLING IMPACT SOCKETS FOR 7/16" TO 3/4" NUTS

1. Insert the hex end of the socket adaptor (1) into the hex drive (2) (Fig. 12).
2. Select the correct socket size.
3. Push the square end of the socket (3) onto the matching square end of the adaptor (4).

NOTE: Make sure the socket is fully installed onto the square portion of the adaptor.

REMOVING NUTS

1. Press the forward/reverse button to the RIGHT for removing nuts (Fig. 5).
2. Place the socket fully onto the nut.
3. Hold the nut driver socket and impact driver firmly against the nut with both hands. With the nut driver aligned with the nut, squeeze the trigger switch to start the impact driver and remove the nut.

NOTE: When removing fasteners, do not allow the impact driver to operate more than 5 seconds unless the fastener begins to turn. If the fastener fails to turn within 5 seconds, reverse the direction of rotation and operate the impact driver in a forward direction on the fastener for a few seconds. Now switch back to reverse direction and remove the fastener. This procedure will usually break loose seized or “frozen” fasteners.

⚠ WARNING: Operating the impact driver for more than 5 seconds at a time on a seized or “frozen” fastener will place severe stress on the impact driver and cause damage. It may also break the fastener.

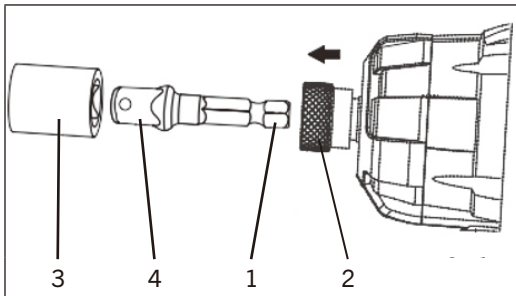

FIG. 12

MAINTENANCE

GENERAL

⚠️ WARNING: When servicing, use only identical replacement parts. The use of any other part may create a hazard or cause product damage.

DO NOT use solvents when cleaning plastic parts. Plastics are susceptible to damage from various types of commercial solvents and may be damaged by their use. Use a clean cloth to remove dirt, dust, oil, grease etc.

⚠️ WARNING: DO NOT allow brake fluids, gasoline, petroleum-based products, penetrating oils, etc. to come into contact with plastic parts. They contain chemicals that can damage, weaken, or destroy plastic.

DO NOT abuse power tools. Abusive practices can damage the tool and the workpiece.

⚠️ WARNING: DO NOT attempt to modify tools or create accessories. Any such alteration or modification is misuse and could result in a hazardous condition leading to possible serious injury. It will also void the warranty.

LUBRICATION

All of the bearings in this tool are lubricated with a sufficient amount of high-grade lubricant for the life of the unit under normal conditions. Therefore, no further lubrication is required.

LITHIUM-ION BATTERY PERFORMANCE

Lithium-ion rechargeable batteries generally provide superior performance to nickel-cadmium batteries when used in power tools.

- Faster charges
- Longer battery life
- More power
- Lighter weight

Lithium-ion batteries perform best and deliver peak output power at room temperature (20° C or 68° F). When operated in lower temperatures, the battery output will be reduced and it will NOT function below -20° C (-4° F). The output power will increase as the heat generated by the battery during use increases the internal temperature of the battery. The result is increased power as the tool is used.

LITHIUM-ION BATTERY MAINTENANCE

Lithium-ion batteries share many characteristics with nickel-cadmium batteries.

The major characteristic that is NOT shared with nickel-cadmium batteries is that Lithium-ion batteries do not have a “memory” and do not require to be completely discharged periodically. It is recommended that you charge your Lithium-ion batteries after each use so they will be fully charged when needed.

NOTE: A fully charged battery will lose about 2% of its charge per month during storage.

BATTERY PACK REMOVAL AND PREPARATION FOR RECYCLING

To preserve our natural resources, please recycle or dispose of batteries properly.

The batteries supplied with this tool may contain chemicals and metals that are harmful to the environment. Never dispose of rechargeable batteries in your normal household garbage or land fill sites because they will add to the pollution of the environment.

Consult your local waste authority for information regarding available recycling and disposal options.

 WARNING: If the battery pack has been removed from the tool, cover the terminals of the battery pack with electrical tape or heavy-duty adhesive tape. Never touch both terminals with metal objects or body parts, because a short circuit may result. Keep away from children. Do not attempt to destroy or disassemble battery pack or remove any of its components. Rechargeable batteries must be recycled or disposed of properly. Failure to comply with these warnings could result in fire and serious injury.

 WARNING: When servicing, use only original equipment replacement parts. The use of any other parts may create a safety hazard or cause damage to the tool. Any attempt to repair or replace electrical parts on this tool may create a safety hazard unless repairs are performed by a qualified technician. For more information, call the Toll-free helpline at 1-866-349-8665.

EXPLODED VIEW

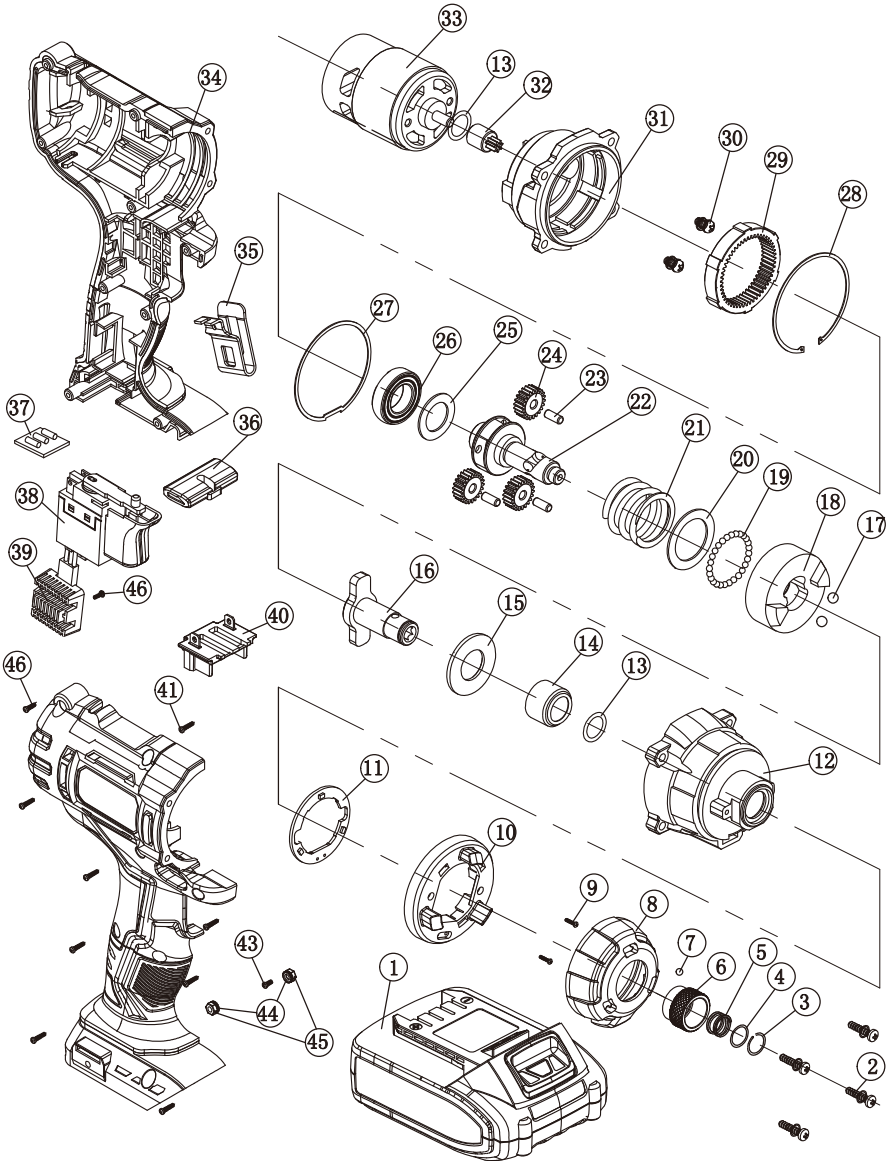

PARTS LIST

Always order by part number.

KEY #	PART #	PART NAME / QUANTITY	KEY #	PART #	PART NAME / QUANTITY
1	1290090019	Battery pack/1	25	2030020229	Washer (5) / 1
2	4030010263	ST3.9X25 / 1	26	4010010062	Bearing (6902z) / 1
3	2050080131	Outer circlip / 1	27	3190090011	Oil Proof Washer / 1
4	2030020001	Washer / 1	28	4100010013	Internal Circlip / 1
5	2050060004	Assembly sleeve spring / 1	29	2010090070	Inner Ring / 1
6	2040170007	Assembly sleeve / 1	30	4020010043	M4X8 / 2
7	4080030001	Ball ϕ 3.5 / 1	31	2020010027	Gear Box / 1
8	3140100022	Rubber sleeve / 1	32	2010180026	Motor Gear / 1
9	4020020028	M3X8 / 2	33	1039080004	Motor / 1
10	3150160282	Circuit Board Setting Ring / 1	34	3010020043	Enclosure / 1
11	1130040080	Aluminum Shell / 1	35	2030100069	Hook / 1
12	2020050098	Led Circuit Board / 1	36	3120030144	Direction Setting Button / 1
13	3140020001	O Type Ring / 1	37	1130030085	LED Circuit Board / 1
14	2010080002	Shaft Coat / 1	38	1060050017	Switch / 1
15	2030020002	Washer / 1	39	2020180005	Cooling Block / 1
16	2040050141	Outer Shaft / 1	40	3150170016	Electrode Plate / 1
17	4080070001	Ball 5.5 / 2	41	4030010145	ST2.9X16 Bald / 1
18	2040200011	Impact Block / 1	42	4030010039	ST2.9X20 Bald / 1
19	4080040001	Ball 4 / 21	43	4020010168	M3 X 12 / 1
20	2030020003	Washer 3 / 1	44	4040080003	Serrated Ring / 2
21	2050060181	Torque Spring / 1	45	4060010003	M3 Hexagon Nut / 2
22	2040050106	Inner Shaft / 1	46		
23	2040050106	Pin 4x9.8 / 3	47		
24	2010010064	Planetary Gear / 3	48		

⚠ WARNING: When servicing, use only original equipment replacement parts. The use of any other parts may create a safety hazard or cause damage to the tool.

Any attempt to repair or replace electrical parts on this tool may create a safety hazard unless repairs are performed by a qualified technician. For more information, call the Toll-free Helpline, at 1-866-349-8665.

WARRANTY

If this Benchmark tool fails due to a defect in material or workmanship within five years from the date of purchase, return it to any Home Hardware store with the original bill of sale for exchange. 3-year warranty for the battery and charger. This warranty does not include expendable parts including but not limited to blades, brushes, belts, light bulbs.

This warranty covers defects in material or workmanship only. It does not cover normal wear and tear, failure due to abuse/misuse, or defects caused by careless or accidental mishandling. If this Benchmark product is used for commercial or rental purposes, this warranty does not apply.

20V MAX IMPACT DRIVER



5 Year Limited Warranty
3 Year Limited Warranty on
Battery and Charger

BENCHMARK™
MC

BENCHMARK TOOLS CANADA
ST. JACOBS, ONTARIO N0B 2N0
© 2020 Home Hardware Stores Limited

CUSTOMER SERVICE/TECH SUPPORT
1-866-349-8665

1239-104

Made in China



* This Benchmark™ product carries a five (5) year LIMITED warranty against defects in workmanship and materials. The charger and batteries carry a three (3) year LIMITED warranty. See Owner's Manual for full details.



JD509920

**READ ALL INSTRUCTIONS BEFORE FIRST USE.
KEEP THIS MANUAL FOR FUTURE REFERENCE.
KEEP AWAY FROM CHILDREN.**

Maximum initial battery voltage (measured without a load)
is 20 volts. Nominal voltage is 18 volts.



**WEAR CSA APPROVED
EYE PROTECTION**



**WEAR EAR
PROTECTION**



**WEAR A
FACE MASK**

BENCHMARKTM MC

20V MAX VARIABLE SPEED RECIPROCATING SAW



5 Year Limited Warranty on tool
battery and charger not included
Battery & charger included where applicable



JD522020

**READ ALL INSTRUCTIONS BEFORE FIRST USE.
KEEP THIS MANUAL FOR FUTURE REFERENCE.
KEEP AWAY FROM CHILDREN.**

Maximum initial battery voltage (measured without a load)
is 20 volts. Normal voltage is 18 volts.



**WEAR CSA APPROVED
EYE PROTECTION**



**WEAR EAR
PROTECTION**



**WEAR A
FACE MASK**

PRODUCT SPECIFICATIONS

20V MAX VARIABLE SPEED RECIPROCATING SAW	
Voltage	20V MAX*
Variable Speed	0-3,000 SPM
Length of Stroke	1" (25.4 mm)
Max. Cutting Capacity - Wood	(w/12" blade) 3-1/8" (80 mm)
Max. Cutting Capacity - Pipe	3/4" (20 mm)
Max. Cutting Capacity - Steel	3/8" (10 mm)
Electric Brake	Yes
Batteries (Sold Separately)	5350-023 (2.5Ah), 5350-011 (4Ah), 5350-012 (5Ah)
Charger (Sold Separately)	5350-010 2.4Amp 5350-022 6 A Fast Charger
Tool Weight	3.7Lb (1.67Kg) Tool Only

NEED ASSISTANCE?

Call our toll-free customer support line:

1-866-349-8665 (Monday through Friday 9am – 5pm Eastern Standard Time)

- Technical questions
- Replacement parts
- Parts missing from package











TABLE OF CONTENTS

Product Specifications.....	1
Table of Contents.....	2
General Safety Warnings.....	3
Specific Reciprocating Saw Safety.....	6
Safety Symbols.....	7
Know your 20v Max VS Reciprocating Saw.....	8
Operation and Assembly.....	9
Maintenance.....	14
Exploded View.....	16
Parts List.....	17
Warranty.....	18

GENERAL SAFETY WARNINGS

WARNING:

Before using this tool or any of its accessories, read this manual and follow all Safety Rules and Operating Instructions. The important precautions, safeguards and instructions appearing in this manual are not meant to cover all possible situations. It must be understood that common sense and caution are factors which cannot be built into the product.

SYMBOL	MEANING
<p> DANGER</p>  	<p>ALWAYS WEAR EYE PROTECTION THAT CONFORMS WITH CSA Z94.3 or ANSI SAFETY STANDARD Z87.1</p> <p>FLYING DEBRIS can cause permanent eye damage. Prescription eyeglasses ARE NOT a replacement for proper eye protection.</p> <p>Non-compliant eyewear can cause serious injury if broken during the operation of a power tool.</p>
<p> WARNING</p> 	<p>Use hearing protection, particularly during extended periods of operation of the tool, or if the operation is noisy.</p>
<p> WARNING</p> 	<p>WEAR A DUST MASK THAT IS DESIGNED TO BE USED WHEN OPERATING A POWER TOOL IN A DUSTY ENVIRONMENT.</p> <p>Dust that is created by power sanding, sawing, grinding, drilling, and other construction activities may contain chemicals that are known to cause cancer, birth defects, or other genetic abnormalities.</p> <p>These chemicals include:</p> <ul style="list-style-type: none"> • Lead from lead-based paints • Crystalline silica from bricks, cement, and other masonry products • Arsenic and chromium from chemically treated lumber. <p>The level of risk from exposure to these chemicals varies, according to how often this type of work is performed. In order to reduce exposure to these chemicals, work in a well-ventilated area, and use approved safety equipment, such as a dust mask that is specifically designed to filter out microscopic particles.</p>
<p> WARNING</p> 	<p>To avoid electrical hazards, fire hazards or damage to the tool, use proper circuit protection.</p> <p>This tool is wired at the factory for 120 Volts AC operation. It must be connected to a 120 Volts AC, 15 Amps circuit that is protected by a time-delayed fuse or circuit breaker. To avoid shock or fire, replace power cord immediately if it is worn, cut or damaged in any way.</p>
<p> WARNING</p> 	<p>Ventilation openings in batteries and chargers must always be open to allow cooling air to circulate freely. Air vents that are blocked, restricted or covered may result in the battery or charger overheating. Overheating may lead to damage to the tool or cause a fire, resulting in possible serious injury.</p>

POWER TOOL SAFETY WARNING

 **WARNING:** Read all safety warnings and all instructions. Failure to follow the warnings and instructions may result in electric shock, fire and/or serious injury.

Save all warnings and instructions for future reference.

WORK AREA SAFETY

Keep work area clean and well lit. Cluttered or dark areas invite accidents.

Do not operate power tools in explosive atmospheres, such as in the presence of flammable liquids, gases or dust. Power tools create sparks which may ignite the dust or fumes.

Keep children and bystanders away while operating a power tool. Distractions can cause you to lose control.

ELECTRICAL SAFETY

Power tool plugs must match the outlet. Never modify the plug in any way.

Do not use any adapter plugs with earthed (grounded) power tools. Unmodified plugs and matching outlets will reduce risk of electric shock.

Avoid body contact with earthed or grounded surfaces such as pipes, radiators, ranges and refrigerators. There is an increased risk of electric shock if your body is earthed or grounded.

Do not expose power tools to rain or wet conditions. Water entering a power tool will increase the risk of electric shock.

Do not abuse the cord. Never use the cord for carrying, pulling or unplugging the power tool. Keep cord away from heat, oil, sharp edges or moving parts.

Damaged or entangled cords increase the risk of electric shock.

When operating a power tool outdoors, use an extension cord suitable for outdoor use. Use of a cord suitable for outdoor use reduces the risk of electric shock.

If operating a power tool in a damp location is unavoidable, use a residual current device (RCD) protected supply. Use of a ground fault circuit interrupter (GFCI) protected supply. Use of a ground fault circuit interrupter (GFCI) reduces the risk of electric shock.

PERSONAL SAFETY

Stay alert, watch what you are doing and use common sense when operating a power tool. Do not use a power tool while you are tired or under the influence of drugs, alcohol, or medication. A moment of inattention while operating power tools may result in serious personal injury.

Use personal protective equipment. Always wear eye protection. Protective equipment such as dust mask, non-skid safety shoes, hard hat, or hearing protection used for appropriate conditions will reduce personal injuries.

Prevent unintentional starting. Ensure the switch is in the off-position before connecting to power source and/or battery pack, picking up or carrying the tool. Carrying power tools with your finger on the switch or energizing power tools that have the switch on invites accidents.

Do not overreach. Keep proper footing and balance at all times. This enables better control of the power tool in unexpected situations.

Dress properly. Do not wear loose clothing or jewellery. Keep your hair, clothing, and gloves away from moving parts. Loose clothes, jewellery or long hair can be caught in moving parts.

If devices are provided for the connection of dust extraction and collection facilities, ensure these are connected and properly used. Use of dust collection can reduce dust-related hazards.

POWER TOOL USE AND CARE

DO NOT force the power tool. Use the correct power tool for your application. The correct power tool will do the job better and safer at the rate for which it was designed. **DO NOT** use the power tool if the switch does not turn it on and off. Any power tool that cannot be controlled with the switch is dangerous and must be repaired.

Disconnect the plug from the power source and/or the battery pack from the power tool before making any adjustments, changing accessories, or storing power tools. Such preventive safety measures reduce the risk of starting the power tool accidentally.

Store idle power tools out of the reach of children and **DO NOT** allow persons unfamiliar with the power tool or these instructions to operate the power tool. Power tools are dangerous in the hands of untrained users.

Maintain power tools. Check for misalignment or binding of moving parts, breakage of parts and any other condition that may affect the power tool's operation. If damaged, have the power tool repaired before use. Many accidents are caused by poorly maintained power tools.

Keep cutting tools sharp and clean. Properly maintained cutting tools with sharp cutting edges are less likely to bind and are easier to control.

Use the power tool, accessories and tool bits, etc. in accordance with these instructions, taking into account the working conditions and the work to be performed. Use of the power tool for operations different from those intended could result in a hazardous situation.

Hold power tool by insulated gripping surfaces, when performing an operation where the fastener may contact hidden wiring or its own cord. Fasteners contacting a "live" wire may make exposed metal parts of the power tool "live" and could give the operator an electric shock.

Use clamps or other practical ways to secure and support the workpiece to a stable platform. Holding the workpiece by hand or against your body leaves it unstable and may lead to loss of control.

SERVICE

Have your power tool serviced by a qualified repair person using only identical replacement parts. This will ensure that the safety of the power tool is maintained.

BATTERY TOOL USE AND CARE

Recharge only with the charger specified by the manufacturer. A charger that is suitable for one type of battery pack may create a risk of fire when used with another battery pack.

Use power tools only with specifically designated battery packs.

Use of any other battery packs may create a risk of injury and fire.

When battery pack is not in use, keep it away from other metal objects, like paper clips, coins, keys, nails, screws, or other small metal objects that can make a connection from one terminal to another. Shorting the battery terminals together may cause burns or a fire.

Under abusive conditions, liquid may be ejected from the battery; avoid contact. If contact accidentally occurs, flush with water. If liquid contacts eyes, additionally seek medical help. Liquid ejected from the battery may cause irritation or burns.

SPECIFIC SAFETY INSTRUCTIONS FOR 20V RECIPROCATING SAW

⚠️ WARNING: Know your reciprocating saw. DO NOT plug in the charger or install the battery in the tool until you have read and understand this Instruction Manual. Learn the tool's applications and limitations, as well as the specific potential hazards related to this tool. Following this rule will reduce the risk of electric shock, fire, or serious injury.

Always keep hands out of the path of the saw blade. Avoid awkward hand positions where a sudden slip could cause your hand to move into the path of the saw blade.

⚠️ DANGER: Keep hands away from cutting area and the blade. Keep your second hand on the tool. If both hands are holding the saw, they cannot be cut by the blade.

Do not reach underneath the workpiece.



















Always wear eye protection. Any power tool can throw foreign objects into your eyes and cause permanent eye damage. ALWAYS wear safety goggles (not glasses) that comply with ANSI safety standard Z87.1. Everyday glasses have only impact resistant lenses. They ARE NOT safety glasses.

⚠️ WARNING: Glasses or goggles not in compliance with ANSI Z87.1 could cause serious injury when they break.

SYMBOLS

⚠ WARNING: Some of the following symbols may appear on the reciprocating saw. Study these symbols and learn their meaning. Proper interpretation of these symbols will allow for more efficient and safer operation of this too

V	Volts		Three-phase alternating current with neutral
A	Amperes		Direct current
Hz	Hertz		No load speed
W	Watts		Alternating or direct current
kW	Kilowatts		Class II Construction
μF	Microfarads		Splash-proof construction
L	Litres		Watertight construction
kg	Kilograms		Protective grounding at grounding terminal, Class I tools
H	Hours		Revolutions or reciprocations per minute
N/cm ²	Newtons per square centimetre		Diameter
Pa	Pascals		Off position
OPM	Oscillation per minute		Directional Arrow
Min	Minutes		Warning symbol
S	Seconds		Wear your safety glasses
~ or AC	Alternating current		Wear hearing protection
3 ~	Three-phase alternating current		Wear dust mask



JD522020

This symbol designates that this tool is listed with U.S. and Canadian requirements by cTUVus Testing Laboratories, Inc.
 UL62841-1, UL62841-2-11;
 CSA C22.2#UL62841-1, UL62841-2-11.

KNOW YOUR 20V MAX VS RECIPROCATATION SAW

Tool Free
blade release

Pivoting Shoe

Tool-less
Adjustable shoe

Trigger Lock-off switch

VS trigger

Battery (sold separately)

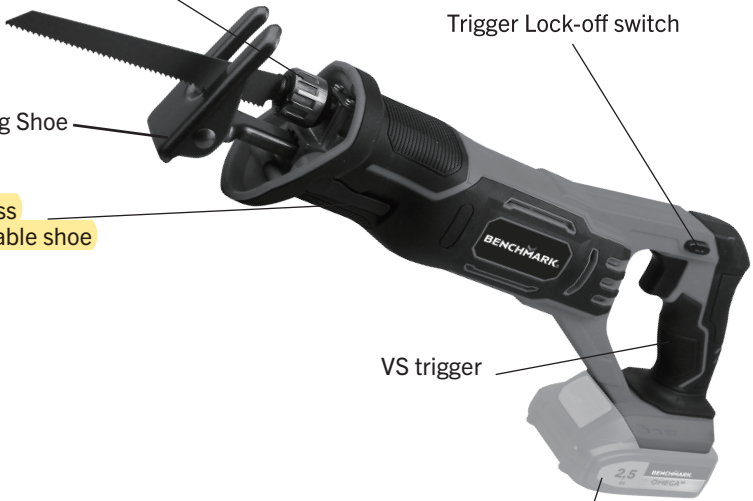

OPERATION AND ASSEMBLY

 **WARNING:** Always use hearing protection when sawing, particularly during extended periods of operation.

 **WARNING:** Always remove the battery before changing the blade and when making any adjustments.

DO NOT wear gloves, neckties or loose clothing.

Hold the tool by its insulated gripping surfaces when performing an operation where the saw blade may contact hidden wiring or its own cord. Contact with a "live" wire will make exposed metal parts of the tool "live" and shock the operator.

Always hold the tool with two hands. Attempting to control the tool with only one hand is dangerous. It could result in loss of control and serious injury.

Never hold the workpiece in one hand and the tool the other hand when sawing. Never place the hands near or below the cutting surface. Clamp the workpiece and guide the tool with both hands.

Always make sure the work surface is free from nails and other foreign objects. Cutting into a nail can cause the blade and the tool to jump and damage the blade.

Never lay the workpiece on hard surfaces like concrete, stone etc. The protruding blade may cause tool to jump.

After changing a blade or making adjustments, make sure the blade clamp is holding the blade securely. Loose blades could be violently thrown from the tool.

Never use dull or damaged blades. Sharp blades must be handled with care. Damaged blades can snap during use. Dull blades require more force to cut the workpiece, possibly causing the blade to break.

Never touch the blade during or immediately after use. After use, the blade is too hot to be touched.

IMPORTANT SAFETY INSTRUCTIONS

The warnings, precautions, and instructions discussed in this manual cannot cover all possible conditions and situations that may occur. The operator must understand that common sense and caution are factors which cannot be built into this product, but must be supplied by the operator.

 **WARNING:** Use only attachments recommended or sold by manufacturer.

1. **DO NOT** disassemble the saw. Take it to a qualified professional when service or repair is required. Incorrect reassembly may result in electric shock or fire.
2. Wear approved safety eye/face shield, ear defenders and hand protection.

DISPOSAL

At the end of the useful life of the Tools by Benchmark 20V MAX* Li-ion Reciprocating Saw, dispose of the components according to all state, federal and local regulations.

PURPOSE

20V Max* Li-ion Reciprocating Saw is ideal for demolition and remodeling. Designed to cut through many types of materials such as wood, metal, PVC and nails.

Always wear safety goggles and gloves.

⚠️WARNING: DO NOT immerse the battery pack in water. Sudden cooling could cause a hot battery to explode or leak.

INSTALLING A BLADE

⚠️WARNING: Always remove the battery from the tool before installing or removing a blade or adjusting the saw in any way.

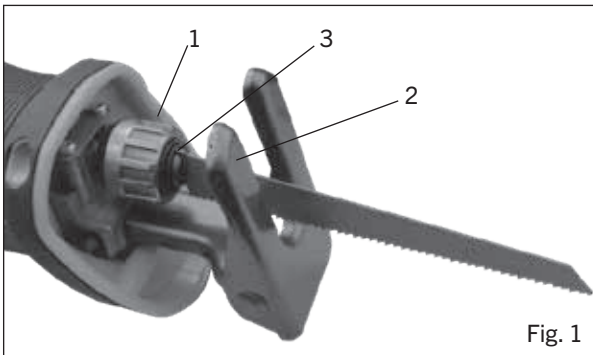

Fig. 1

1. To install a blade in the saw, rotate the blade locking sleeve (1) counter-clockwise (Fig. 1).
2. Insert the appropriate blade (2) into the blade slot (3) as far as it will go.
3. Release the blade locking sleeve.

NOTE: The blade will automatically be locked into the blade holder. Pull outward on the blade to ensure it is properly locked into the blade holder.

REMOVING A BLADE

To remove a blade, simply rotate the blade locking sleeve counter clockwise and remove the blade from the blade holder.

ADJUSTING THE PIVOTING SHOE

1. The pivoting shoe will pivot to follow the angle of the blade to the workpiece. This action ensures the flat surface of the shoe is against the workpiece for better cutting action and easier control of the saw.
2. The shoe can be adjusted in or out, allowing the use of the blade teeth at different points on the blade. This will provide longer blade life as one section of the blade becomes dull.
3. To adjust the pivoting shoe, rotate the pivoting shoe adjusting lever to its downward position.
4. Slide the pivoting shoe in or out until it is in the appropriate position.
5. Lock the pivoting shoe in place by rotating the pivoting shoe adjusting lever upward to its original horizontal position.

LOCK-OUT SWITCH

1. The lock-out switch (1) is a safety device designed to reduce the possibility of a user accidentally starting the saw. (Figure 2)
2. This switch must be pressed before the trigger (2) switch can be squeezed.

NOTE: The lock-out switch can be pressed from either the left or right side of the handle.

VARIABLE SPEED TRIGGER SWITCH

The trigger switch turns the reciprocating saw ON and OFF as well as controlling the speed.

1. To turn the saw ON, press the lock-out switch with your thumb. (Figure 2)
2. While holding the lock-out switch in the pressed position, squeeze the trigger (2) switch to start the saw. (Fig.3)
3. Once the saw starts, release the lock-out switch. The saw will remain running until the trigger switch is released.

NOTE: The trigger switch also controls the speed at which the saw runs. The more you squeeze the trigger, the faster the saw will run.

4. To turn the saw OFF, release the trigger switch.

NOTE: To re-start the saw, the lock-out switch must be pressed again before the trigger switch is squeezed.

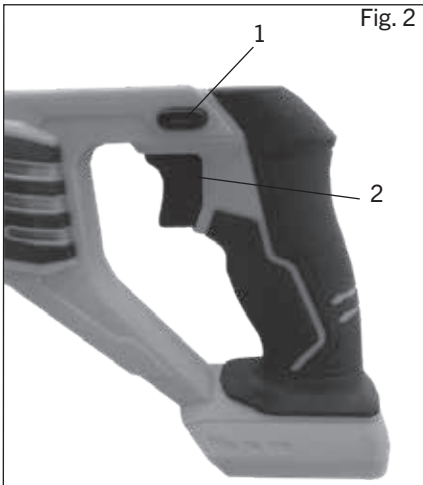

Fig. 2

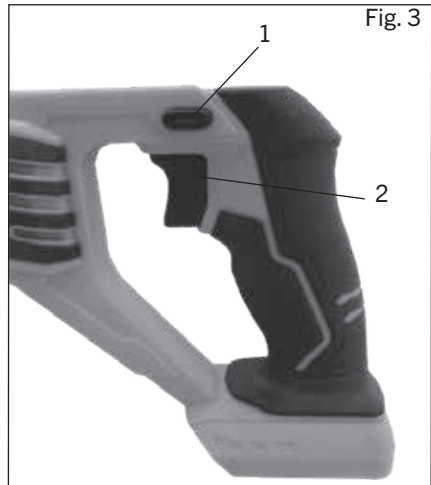

Fig. 3

MATERIALS YOU CAN CUT

This reciprocating saw is a versatile tool that allows you to cut many different types of materials. Some of these materials include:

- Wood products such as lumber, hardwood, plywood, composite board, and paneling

NOTE: There are many different types of blades available. Generally, there are metal cutting blades (fine teeth) and wood cutting blades (coarse teeth). Use the correct blade for your application. The packaging on the blade will indicate the type of materials each blade is designed to cut.

GENERAL CUTTING

1. Clearly mark the workpiece to locate the position of the cut.
2. Hold smaller workpieces with a vice. Clamp larger workpieces to a workbench or table.

 **WARNING:** Any workpiece that is not adequately clamped in place may come loose and cause serious injury. Never hold the workpiece with your hand.

3. Make sure there are no nails, screws, clamps or foreign materials in
4. Hold the saw away from your body and in front of you.
5. With both hands firmly gripping the saw, and with the blade NOT in contact with the surface to be cut, start the saw by pressing the lock-out switch and squeezing the trigger switch.
6. Once the saw has reached the desired speed, place the adjustable pivoting shoe against the workpiece and gradually bring the moving blade into contact with the workpiece at the appropriate location.

CAUTION

DO NOT force the saw. Use only enough force to keep the blade cutting. Excessive pressure on the blade will cause it to bend and twist, which may result in breaking the blade.

PLUNGE CUTTING

1. Clearly mark the workpiece to locate the position of the cut.
2. Clamp the workpiece to a workbench or table.

NOTE: Make sure the area to be cut is clear under the workpiece so that the blade will not come into contact with anything other than the workpiece.

3. Select a convenient starting point in the area to be cut out. Place the tip of the blade over that point.
4. Rest the lower edge of the adjustable pivoting shoe on the workpiece and hold it firmly in that position, maintaining a shallow cutting angle.
5. Press the lock-out switch and squeeze the trigger switch to start the saw.

 **WARNING:** Make sure the blade does not touch the workpiece until the saw reaches full speed. Loss of control and possible injury could result.

6. With the saw running at full speed, slowly tilt the saw until the tip of the blade contacts the workpiece and begins to cut. After the blade cuts through the workpiece, tilt the saw upward until the blade is perpendicular to the workpiece.

METAL CUTTING

1. Metals such as pipe, steel rods, sheet steel, aluminum, brass and copper can be cut with your reciprocating saw.
2. To cut thin sheet material, "sandwich" the material between hardboard or plywood and clamp the layers to limit vibration and material tearing.
3. Always use a fine toothed metal cutting blade and run the saw at medium speeds when cutting metal.
4. Use cutting oil to keep the blade cool, increase cutting **DO NOT** twist or bend the saw blade.
5. **DO NOT** force the saw blade. Let it cut at its own speed.

 **WARNING:** Always clamp the workpiece in a vice, or to a workbench or table. **DO NOT** hold workpiece in your hand. Never use gasoline as a lubricant or as a cleaning agent. A spark from the motor may cause an explosion. Gasoline will also damage the plastic components of the saw.

MAINTENANCE

⚠ WARNING: When servicing, use only identical replacement parts. The use of any other part may create a hazard or cause product damage.

DO NOT use solvents when cleaning plastic parts. Plastics are susceptible to damage from various types of commercial solvents and may be damaged by their use. Use a clean cloth to remove dirt, dust, oil, grease, etc.

⚠ WARNING: DO NOT allow brake fluids, gasoline, petroleum-based products, penetrating oils, etc. to come into contact with plastic parts. They contain chemicals that can damage, weaken or destroy plastic.

DO NOT abuse power tools. Abusive practices can damage the tool and the workpiece.

⚠ WARNING: DO NOT attempt to modify tools or create accessories. Any such alteration or modification is misuse and could result in a hazardous condition leading to possible serious injury. It will also void the warranty.

NOTE: It has been found that electric tools are subjected to accelerated wear and possible premature failure when they are used on fiberglass boats and sports cars, wallboard, spackling compounds or plaster. The chips and grindings from these materials are highly abrasive to electric tool parts such as bearings, brushes, commutators, etc. Consequently, it is not recommended that this tool be used for extended work on any fiberglass material, wallboard, spackling compounds or plaster. During any use on these materials, it is extremely important that the tool is cleaned frequently by blowing it out with an air jet.

LUBRICATION

All of the bearings in this tool are lubricated with a sufficient amount of high-grade lubricant for the life of the unit under normal conditions. Therefore, no further lubrication is required.

MAINTENANCE

⚠️ WARNING: When servicing, use only identical replacement parts. The use of any other part may create a hazard or cause product damage.

DO NOT use solvents when cleaning plastic parts. Plastics are susceptible to damage from various types of commercial solvents and may be damaged by their use. Use a clean cloth to remove dirt, dust, oil, grease, etc.

⚠️ WARNING: Do not allow brake fluids, gasoline, petroleum-based products, penetrating oils, etc. to come into contact with plastic parts. They contain chemicals that can damage, weaken or destroy plastic.

DO NOT abuse power tools. Abusive practices can damage the tool and the workpiece.

⚠️ WARNING: DO NOT attempt to modify tools or create accessories. Any such alteration or modification is misuse and could result in a hazardous condition leading to possible serious injury. It will also void the warranty.

Remove accumulated dust and debris regularly using a soft DRY brush.

It has been found that electric tools are subjected to accelerated wear and possible premature failure when they are used on fiberglass boats and sports cars, wallboard, spackling compounds or plaster. The chips and grindings from these materials are highly abrasive to electric tool parts such as bearings, brushes, commutators, etc. Consequently, it is not recommended that this tool be used for extended work on any fiberglass material, wallboard, spackling compounds or plaster. During any use on these materials it is extremely important that the tool is cleaned frequently by blowing it out with an air jet.

⚠️ WARNING: Always wear safety goggles or safety glasses with side shields during all sanding operations. It is critical that you also wear safety goggles or safety glasses with side shields and a dust mask while blowing dust out of the cut-out tool with an air jet. Failure to take these safety precautions could result in permanent eye or lung damage.

LUBRICATION

All of the bearings in this compact detail sander are lubricated with a sufficient amount of high grade lubricant for the life of the unit under normal conditions. Therefore, no further lubrication is required.

EXPLODED VIEW

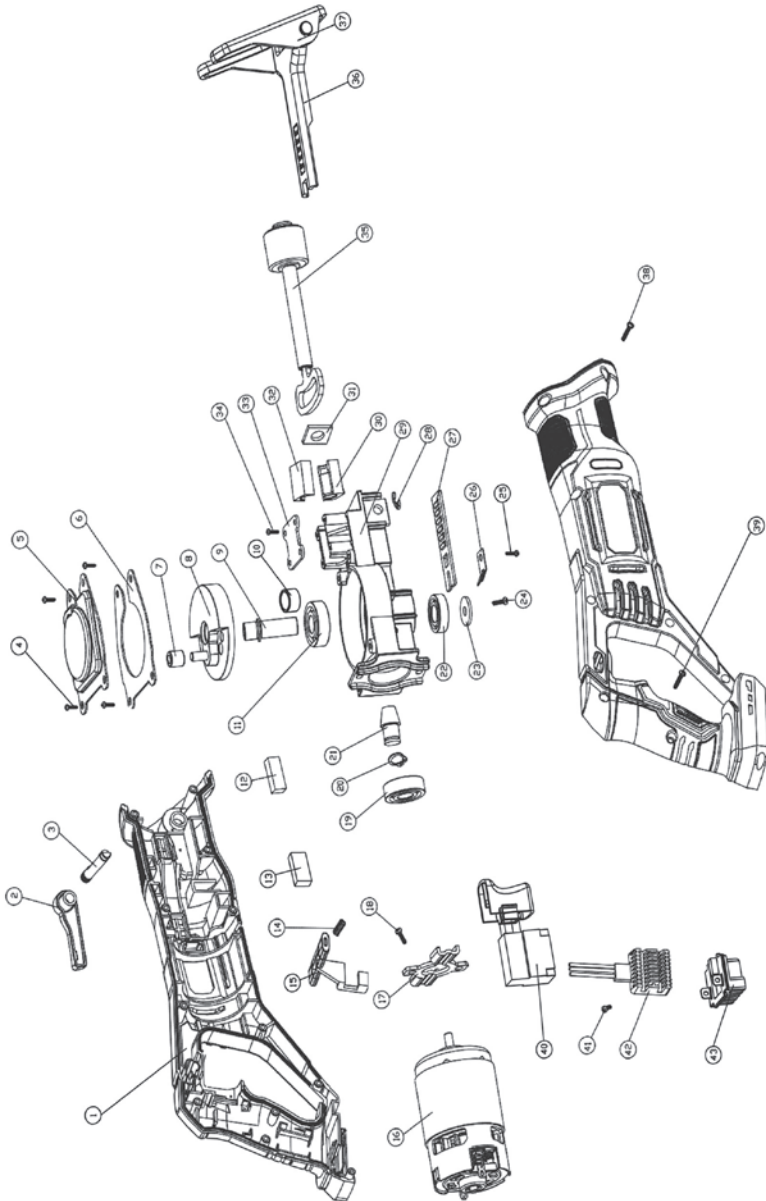

PARTS LIST

⚠ WARNING: When servicing, use only original equipment replacement parts. The use of any other parts may create a safety hazard or cause damage to the reciprocating saw .

Any attempt to repair or replace electrical parts on this reciprocating saw may create a safety hazard unless repairs are performed by a qualified technician. For more information, call the Toll-free Helpline, at 1-866-349-8665 Monday – Friday from 9am to 5pm Eastern Standard Time.

Always order by PART NUMBER, not by key number.

Key #	Part #	Part Name	Quantity
1	3010080021	Lock Off Switch	1
2	3120100053	Lever	1
3	2040290084	Insert	1
4	4020010167	Screw M4x12	4
5	2030160145	Gear Box Press Plate	1
6	2030160146	Big Gear Press Plate	1
7	2040310047	Shaft Coat	1
8	2010050041	Big Gear	1
9	2040050145	Shaft	1
10	2010080154	Shaft Coat	1
11	4010010043	Bearing 6000	1
12	3140060053	Front Anti-Vibration Bar	2
13	3140060053	Rear Anti-Vibration Bar	2
14	2050060218	Spring	1
15	3120040079	Lever	1
16	1030240006	Motor	1
17	2030160143	Plate	1
18	4020010186	Screw M5x10	2
19	4010010043	Bearing 6000	1
20	4100020012	Circlip 10	1
21	4010180063	Motor Gear	1
22	4010010022	Bearing 6900	1
23	2030020146	Washer	1
24	4020010161	Screw M5x12	1
25	4020010001	Screw M4x8	1
26	2050070065	Shrapnel	1
27	2030160147	Pressing Plate	1
28	4100020004	Circlip 6	1
29	2020010036	Gear Box	1

Key #	Part #	Part Name	Quantity
30	2010150059	Button Holder	1
31	3140050025	Oil Baffle	1
32	2010150055	Upper Holder	1
33	2030130043	Cover	1
34	4020010168	Screw M3x12	4
35	1150010043	Reciprocating Rod Assembly	1
36	2030100073	Bottom Support	1
37	1150020130	Plate	1
38	4030010106	Screw ST3.9x19	10
39	4030010074	Screw ST3.9x14	2
40	1060050027	Switch	1
41	4020010153	Screw M3x6	1
42	2020180023	Cooling Block	1
43	1180060030	Terminal Plate	1

WARRANTY

20V MAX VARIABLE SPEED RECIPROCATING SAW

If this Benchmark tool fails due to a defect in material or workmanship within five years from the date of purchase, return it to any Home Hardware store with the original bill of sale for exchange. 3-year warranty for the battery and charger. This warranty does not include expendable parts including but not limited to blades, brushes, belts, light bulbs.

This warranty covers defects in material or workmanship only. It does not cover normal wear and tear, failure due to abuse/misuse, or defects caused by careless or accidental mishandling. If this Benchmark product is used for commercial or rental purposes, this warranty does not apply.

20V MAX VARIABLE SPEED RECIPROCATING SAW



5 Year Limited Warranty on tool

BENCHMARKTM
MC

BENCHMARK TOOLS CANADA

ST. JACOBS, ONTARIO N0B 2N0

© 01 / 2021 Home Hardware Stores Limited

CUSTOMER SERVICE/TECH SUPPORT

1-866-349-8665

1239-104

Made in China



* This BenchmarkTM product carries a five (5) year LIMITED warranty against defects in workmanship and materials. The charger and batteries carry a three (3) year LIMITED warranty.



JD522020

**READ ALL INSTRUCTIONS BEFORE FIRST USE.
KEEP THIS MANUAL FOR FUTURE REFERENCE.
KEEP AWAY FROM CHILDREN.**

Maximum initial battery voltage (measured without a load)
is 20 volts. Normal voltage is 18 volts.



**WEAR CSA APPROVED
EYE PROTECTION**



**WEAR EAR
PROTECTION**



**WEAR A
FACE MASK**

BENCHMARKTM MC

20V MAX LED WORKLIGHT



LIMITED
5 YEAR*
WARRANTY

5 Year Limited Warranty on tool
3 Year on battery and chargers
Battery and charger sold separately
Battery & charger included where applicable

**READ ALL INSTRUCTIONS BEFORE FIRST USE.
KEEP THIS MANUAL FOR FUTURE REFERENCE.
KEEP AWAY FROM CHILDREN.**

Maximum initial battery voltage (measured without a load)
is 20 volts. Nominal voltage is 18 volts.



**WEAR CSA APPROVED
EYE PROTECTION**



**WEAR EAR
PROTECTION**



**WEAR A
FACE MASK**

PRODUCT SPECIFICATIONS

20V MAX LED LIGHT	
Voltage	20V
LED Light levels	2
Wattage	3W LED (Equals 130 LUMENS)
Rotation	360°
Tilts	90°
Weight	0.5Lb (0.2KG) Worklight Only
Batteries (Sold Separately)	5350-023 (2.5Ah), 5350-011 (4Ah), 5350-012 (5Ah)
Charger (Sold Separately)	5350-010 2.4Amp

NEED ASSISTANCE?

Call us on our toll-free customer support line:
1-866-349-8665 (Monday through Friday 9am – 5pm Eastern Standard Time)

- Technical questions
- Replacement parts
- Parts missing from package

TABLE OF CONTENTS

Product Specifications 1
Table of Contents 2
General Safety Instructions 3
Work Area Safety 3
Electrical Safety 3
Personal Safety 3
Power Tool Use and Care 4
Battery Tool Use and Care 5
Service 5
Symbols 5
Know Your 20V Max LED Light 6
Tool Assembly 6
Installing the Belt Clip 6
How to Use the 20v Max LED Light 7
Maintenance 7
Warranty 7
Exploded View 8
Parts List 8

GENERAL SAFETY INSTRUCTIONS

⚠️ WARNING: Read all safety warnings and all instructions. Failure to follow the warnings and instructions may result in electric shock, fire and/or serious injury. **Save all warnings and instructions for future reference.** The term “power tool” in the warnings refers to your mains-operated (corded) power tool or battery-operated (cordless) power tool.

WORK AREA SAFETY

- a) **Keep work area clean and well lit.** Cluttered or dark areas invite accidents.
- b) **Do not operate power tools in explosive atmospheres, such as in the presence of flammable liquids, gases or dust.** Power tools create sparks which may ignite the dust or fumes.
- c) **Keep children and bystanders away while operating a power tool.** Distractions can cause you to lose control.

ELECTRICAL SAFETY

- a) **Power tool plugs must match the outlet. Never modify the plug in any way.** Do not use any adapter plugs with earthed (grounded) power tools. Unmodified plugs and matching outlets will reduce risk of electric shock.
- b) **Avoid body contact with earthed or grounded surfaces, such as pipes, radiators, ranges and refrigerators.** There is an increased risk of electric shock if your body is earthed or grounded.
- c) **Do not expose power tools to rain or wet conditions.** Water entering a power tool will increase the risk of electric shock.
- d) **Do not abuse the cord. Never use the cord for carrying, pulling or unplugging the power tool. Keep cord away from heat, oil, sharp edges or moving parts.** Damaged or entangled cords increase the risk of electric shock.
- e) **When operating a power tool outdoors, use an extension cord suitable for outdoor use.** Use of a cord suitable for outdoor use reduces the risk of electric shock.
- f) **If operating a power tool in a damp location is unavoidable, use a residual current device (RCD) protected supply.** Use of an RCD reduces the risk of electric shock.

PERSONAL SAFETY

- a) **Stay alert, watch what you are doing and use common sense when operating a power tool. Do not use a power tool while you are tired or under the influence of drugs, alcohol or medication.** A moment of inattention while operating power tools may result in serious personal injury.
- b) **Use personal protective equipment. Always wear eye protection.** Protective equipment such as dust mask, non-skid safety shoes, hard hat, or hearing protection used for appropriate conditions will reduce personal injuries.

- c) **Prevent unintentional starting. Ensure the switch is in the off position before connecting to power source and/or battery pack, picking up or carrying the tool.** Carrying power tools with your finger on the switch or energising power tools that have the switch on invites accidents.
- d) **Remove any adjusting key or wrench before turning the power tool on.**
A wrench or a key left attached to a rotating part of the power tool may result in personal injury.
- e) **Do not overreach. Keep proper footing and balance at all times.** This SYMBOLS enables better control of the power tool in unexpected situations.
- f) **Dress properly. Do not wear loose clothing or jewellery. Keep your hair, clothing and gloves away from moving parts.** Loose clothes, jewellery or long hair can be caught in moving parts.
- g) **If devices are provided for the connection of dust extraction and collection facilities, ensure these are connected and properly used.** Use of dust collection can reduce dust-related hazards.

POWER TOOL USE AND CARE

- a) **Do not force the power tool. Use the correct power tool for your application.**
The correct power tool will do the job better and safer at the rate for which it was designed.
- b) **Do not use the power tool if the switch does not turn it on and off.** Any power tool that cannot be controlled with the switch is dangerous and must be repaired.
- c) **Disconnect the plug from the power source and/or the battery pack from the power tool before making any adjustments, changing accessories, or storing power tools.** Such preventive safety measures reduce the risk of starting the power tool accidentally.
- d) **Store idle power tools out of the reach of children and do not allow persons unfamiliar with the power tool or these instructions to operate the power tool.**
Power tools are dangerous in the hands of untrained users.
- e) **Maintain power tools. Check for misalignment or binding of moving parts, breakage of parts and any other condition that may affect the power tool's operation. If damaged, have the power tool repaired before use.** Many accidents are caused by poorly maintained power tools.
- f) **Keep cutting tools sharp and clean.** Properly maintained cutting tools with sharp cutting edges are less likely to bind and are easier to control.
- g) **Use the power tool, accessories and tool bits etc. in accordance with these instructions, taking into account the working conditions and the work to be performed.** Use of the power tool for operations different from those intended could result in a hazardous situation.

BATTERY TOOL USE AND CARE







- a) **Recharge only with the charger specified by the manufacturer.** A charger that is suitable for one type of battery pack may create a risk of fire when used with another battery pack.
- b) **Use power tools only with specifically designated battery packs.** Use of any other battery packs may create a risk of injury and fire.
- c) **When battery pack is not in use, keep it away from other metal objects, like paper clips, coins, keys, nails, screws or other small metal objects, that can make a connection from one terminal to another.** Shorting the battery terminals together may cause burns or a fire.
- d) **Under abusive conditions, liquid may be ejected from the battery; avoid contact. If contact accidentally occurs, flush with water. If liquid contacts eyes, additionally seek medical help.** Liquid ejected from the battery may cause irritation or burns.

SERVICE

- a) **Have your power tool serviced by a qualified repair person using only identical replacement parts.** This will ensure that the safety of the power tool is maintained.

SYMBOLS

The rating plate on your tool may show symbols. These represent important information about the product or instructions on its use.

	Direct current, DC		Waste electrical products should not be disposed of with household waste. Please recycle where facilities exist. Check with your Local Authority or retailer for recycling advice.
	Refer to instruction manual/ booklet		
	General warning		Regulator compliance mark

KNOW YOUR 20V MAX LED LIGHT

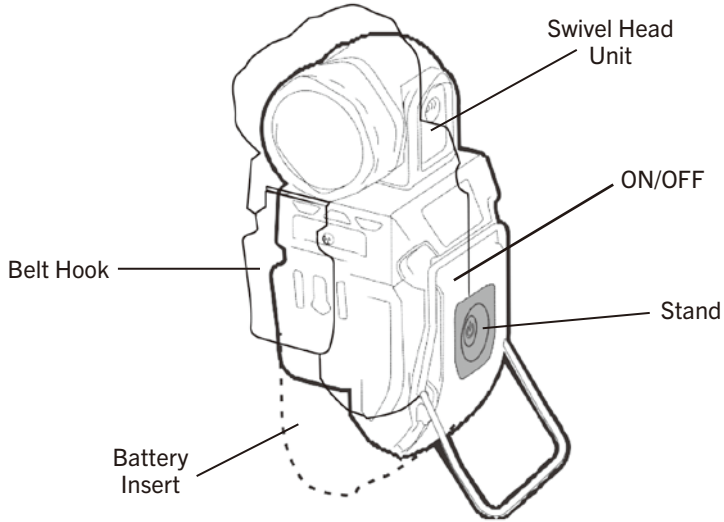

TOOL ASSEMBLY

INSTALLING THE BELT CLIP

Place provided belt clip (4) in the desired position on the side of the torch. Using a Phillips head #2 screwdriver, place screw through clip into screw hole & hand tighten until you feel resistance & clip is adequately tight.

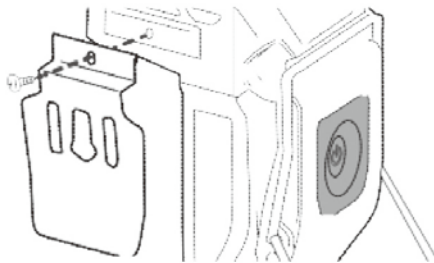

HOW TO USE THE 20V MAX LED LIGHT

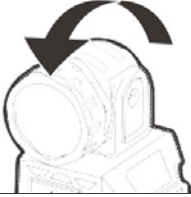
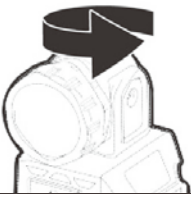
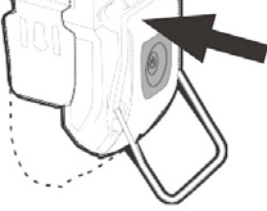
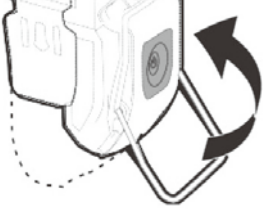
	
<p>VERTICAL SWIVEL (180°)</p>	<p>HORIZONTAL SWIVEL (360°)</p>
	
<p>HOW TO TURN THE LIGHT ON To turn on the light, press the on/off switch (2) once for low light and twice for full light.</p>	<p>HOW TO USE THE STAND The hanger/stand (3) has three available positions: Position 1: Closed Position 2: Used as a stand to hold up the light Position 3: Used to hang the light up allowing for handsfree use</p>

MAINTENANCE

Avoid using solvents when cleaning plastic parts. Most plastics are susceptible to damage from various types of commercial solvents and may be damaged by their use. Use clean cloths to remove dirt, dust, oil, grease, etc.

⚠️ WARNING: Do not at any time let brake fluids, gasoline, petroleum based products, penetrating oils, etc., come in contact with plastic parts. Chemicals can damage, weaken or destroy plastic which may result in serious personal injury.

WARRANTY

BENCH MARK 20V MAX LED LIGHT

If this Benchmark tool fails due to a defect in material or workmanship within five years from the date of purchase, return it to any Home Hardware store with the original bill of sale for exchange. 3-year warranty for the battery and charger. This warranty does not include expendable parts including but not limited to blades, brushes, belts, light bulbs.

This warranty covers defects in material or workmanship only. It does not cover normal wear and tear, failure due to abuse/misuse, or defects caused by careless or accidental mishandling. If this Benchmark product is used for commercial or rental purposes, this warranty does not apply.

EXPLODED VIEW

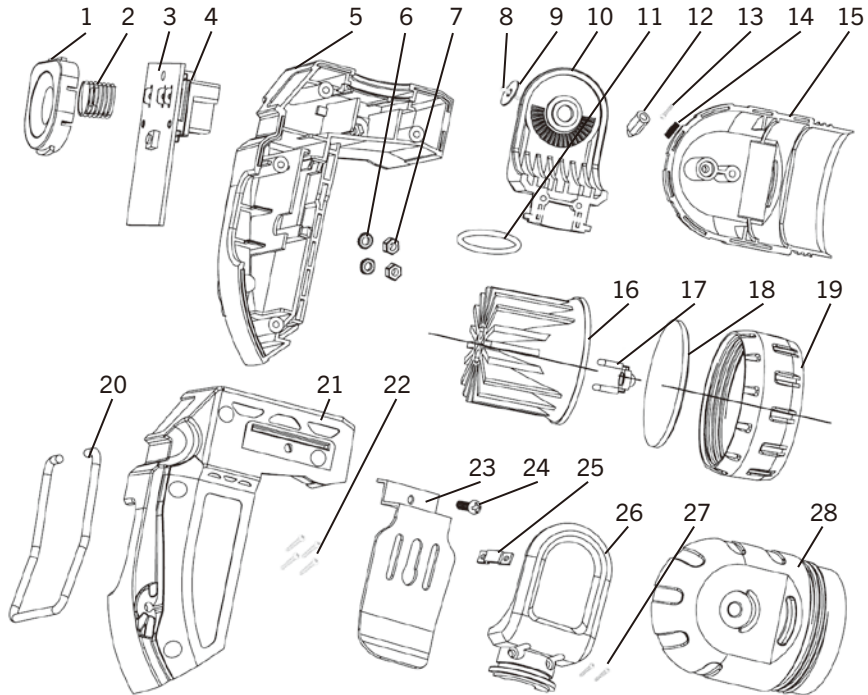

PARTS LIST

KEY #	PART #	PART NAME / QUANTITY	KEY #	PART #	PART NAME
1	3120010084	Switch Button / 1	15	3010120027	Revolving Housing (Left) / 1
2	2050030017	Spring / 1	16	2030030232	Reflector / 1
3	1130030062	Pcb Assembly / 1	17	1220040003	LED Light / 1
4	3150170018	Terminal Plate / 1	18	3180010019	Lens / 1
5	3010120034	Left Housing / 1	19	3160060064	Lens Retainer / 1
6	2030020305	Washer / 2	20	4030010034	Steel Wire / 1
7	4060010039	Nut / 2	21	3010120034	Right Housing / 1
8	4030010034	Screw St 2.9x16 / 1	22	4030010034	Screw St 2.9x16 / 4
9	2030020288	Washer / 1	23	2030090031	Belt Loop / 1
10	3010120025	Left Revolving Support / 1	24	4020010168	Screw M 3x12 / 1
11	3140020046	O Ring / 1	25	3150020008	Cord Clamp / 1
12	3150130127	Pin / 1	26	3010120025	Right Revolving Support / 1
13	4030010012	Screw St 2.5x10 / 1	27	4030010012	Screw St 2.5x10 / 2
14	2050060209	Spring / 1	28	3010120027	Revolving Housing (Right) / 1

20V MAX LED WORKLIGHT

1239-104

20V MAX LED WORKLIGHT



5 Year Limited Warranty on tool
3 Year on battery and chargers
Battery and charger sold separately

BENCHMARK™
MC

BENCHMARK TOOLS CANADA
ST. JACOBS, ONTARIO N0B 2N0
© 2020 Home Hardware Stores Limited

CUSTOMER SERVICE/TECH SUPPORT
1-866-349-8665

1239-104

Made in China



* This Benchmark™ product carries a five (5) year LIMITED warranty against defects in workmanship and materials. The charger and batteries carry a three (3) year LIMITED warranty. See Owner's Manual for full details.

**READ ALL INSTRUCTIONS BEFORE FIRST USE.
KEEP THIS MANUAL FOR FUTURE REFERENCE.
KEEP AWAY FROM CHILDREN.**

Maximum initial battery voltage (measured without a load)
is 20 volts. Nominal voltage is 18 volts.



**WEAR CSA APPROVED
EYE PROTECTION**



**WEAR EAR
PROTECTION**



**WEAR A
FACE MASK**