

BENCHMARKTM MC

20V MAX 1/2" DRILL



5 Year Limited Warranty on tool
3 Year Limited Warranty on battery and charger
Battery & charger included where applicable



JD6318H20

**READ ALL INSTRUCTIONS BEFORE FIRST USE.
KEEP THIS MANUAL FOR FUTURE REFERENCE.
KEEP AWAY FROM CHILDREN.**

Maximum initial battery voltage (measured without a load)
is 20 volts. Nominal voltage is 18 volts.



**WEAR CSA APPROVED
EYE PROTECTION**



**WEAR EAR
PROTECTION**



**WEAR A
FACE MASK**

PRODUCT SPECIFICATIONS

DRILL	
Variable chuck speed	0–450 RPM / 0–1,600 RPM (no load)
Torque clutch positions	16 + drill mode
Keyless chuck	½" keyless
Max torque	380 in/lbs.
Weight	3.8lbs. (1.73kg)
BATTERY & CHARGER	
Battery	20V 2.5Ah Li-ion (Maximum charged battery voltage, measured without load, is 20V with a nominal value of 18V)
Replacement battery	5350-023 (2.5Ah) Charge time – up to 75 minutes)
Replacement charger assembly	5350-010 (2.4A)

NEED ASSISTANCE?

Call us on our toll-free customer support line:
1-866-349-8665 (Monday through Friday 9am – 5pm Eastern Standard Time)

- Technical questions
- Replacement parts
- Parts missing from package

TABLE OF CONTENTS











Product Specifications 1
Table of Contents 2
General Safety Warnings 3-6
Specific Safety Rules 7-8
Battery & Charger Safety 8-9
Symbols 10
Know your Cordless 20V 2VSR Drill 11
Assembly and Operating 12-19
Maintenance 20
Exploded View 21
Parts List 22-23
Warranty 24

GENERAL SAFETY WARNINGS

WARNING:

Before using this tool or any of its accessories, read this manual and follow all Safety Rules and Operating Instructions. The important precautions, safeguards and instructions appearing in this manual are not meant to cover all possible situations. It must be understood that common sense and caution are factors which cannot be built into the product.

EYE, EAR & LUNG PROTECTION

SYMBOL	MEANING
 DANGER  	<p>ALWAYS WEAR EYE PROTECTION THAT CONFORMS WITH CSA Z94.3 or ANSI SAFETY STANDARD Z87.1</p> <p>FLYING DEBRIS can cause permanent eye damage. Prescription eyeglasses ARE NOT a replacement for proper eye protection. Non-compliant eyewear can cause serious injury if broken during the operation of a power tool.</p>
 WARNING 	<p>Use hearing protection, particularly during extended periods of operation of the tool, or if the operation is noisy.</p>
 WARNING 	<p>WEAR A DUST MASK THAT IS DESIGNED TO BE USED WHEN OPERATING A POWER TOOL IN A DUSTY ENVIRONMENT.</p> <p>Dust that is created by power sanding, sawing, grinding, drilling, and other construction activities may contain chemicals that are known to cause cancer, birth defects, or other genetic abnormalities. These chemicals include:</p> <ul style="list-style-type: none"> • Lead from lead-based paints • Crystalline silica from bricks, cement, and other masonry products • Arsenic and chromium from chemically treated lumber. <p>The level of risk from exposure to these chemicals varies, according to how often this type of work is performed. In order to reduce exposure to these chemicals, work in a well-ventilated area, and use approved safety equipment, such as a dust mask that is specifically designed to filter out microscopic particles.</p>
 WARNING 	<p>To avoid electrical hazards, fire hazards or damage to the tool, use proper circuit protection.</p> <p>This tool is wired at the factory for 120 Volts AC operation. It must be connected to a 120 Volts AC, 15 Amps circuit that is protected by a time-delayed fuse or circuit breaker. To avoid shock or fire, replace power cord immediately if it is worn, cut or damaged in any way.</p>
 WARNING 	<p>Ventilation openings in batteries and chargers must always be open to allow cooling air to circulate freely. Air vents that are blocked, restricted, or covered may result in the battery or charger overheating. Overheating may lead to damage to the tool or cause a fire, resulting in possible serious injury.</p>

 **WARNING:**

Read all safety warnings and instructions. Failure to follow the warnings and instructions may result in electric shock, fire and/or serious injury.

SAVE ALL WARNINGS AND INSTRUCTIONS FOR FUTURE REFERENCE.

WORK AREA SAFETY

Keep work area clean and well lit. Cluttered or dark areas invite accidents.

Do not operate power tools in explosive atmospheres, such as in the presence of flammable liquids, gases or dust. Power tools create sparks which may ignite the dust or fumes.

Keep children and bystanders away while operating a power tool. Distractions can cause you to lose control.

ELECTRICAL SAFETY

Power tool plugs must match the outlet. Never modify the plug in any way. Do not use any adapter plugs with earthed (grounded) power tools. Unmodified plugs and matching outlets will reduce risk of electric shock.

Avoid body contact with earthed or grounded surfaces such as pipes, radiators, ranges, and refrigerators. There is an increased risk of electric shock if your body is earthed or grounded.

Do not expose power tools to rain or wet conditions. Water entering a power tool will increase the risk of electric shock.

Do not abuse the cord. Never use the cord for carrying, pulling, or unplugging the power tool. Keep cord away from heat, oil, sharp edges or moving parts. Damaged or entangled cords increase the risk of electric shock.

When operating a power tool outdoors, use an extension cord suitable for outdoor use. Use of a cord suitable for outdoor use reduces the risk of electric shock.

If operating a power tool in a damp location is unavoidable, use a residual current device (RCD) protected supply. Use of a ground fault circuit interrupter (GFCI) reduces the risk of electric shock.

PERSONAL SAFETY

Stay alert, watch what you are doing and use common sense when operating a power tool. Do not use a power tool while you are tired or under the influence of drugs, alcohol, or medication. A moment of inattention while operating power tools may result in serious personal injury.

Use personal protective equipment. Always wear eye protection. Protective equipment such as dust mask, non-skid safety shoes, hard hat, or hearing protection used for appropriate conditions will reduce personal injuries.

Prevent unintentional starting. Ensure the switch is in the off position before connecting to power source and/or battery pack, picking up or carrying the tool. Carrying power tools with your finger on the switch or energizing power tools that have the switch on invites accidents.

Remove any adjusting key or wrench before turning the power tool on. A wrench or a key left attached to a rotating part of the power tool may result in personal injury.

Do not overreach. Keep proper footing and balance at all times. This enables better control of the power tool in unexpected situations.

Dress properly. Do not wear loose clothing or jewellery. Keep your hair, clothing, and gloves away from moving parts. Loose clothes, jewellery or long hair can be caught in moving parts.

If devices are provided for the connection of dust extraction and collection facilities, ensure these are connected and properly used. Use of dust collection can reduce dust-related hazards.

POWER TOOL USE AND CARE

Do not force the power tool. Use the correct power tool for your application. The correct power tool will do the job better and safer at the rate for which it was designed.

Do not use the power tool if the switch does not turn it on and off. Any power tool that cannot be controlled with the switch is dangerous and must be repaired.

Disconnect the plug from the power source and/or the battery pack from the power tool before making any adjustments, changing accessories, or storing power tools. Such preventive safety measures reduce the risk of starting the power tool accidentally.

Store idle power tools out of the reach of children and do not allow persons unfamiliar with the power tool or these instructions to operate the power tool. Power tools are dangerous in the hands of untrained users.

Maintain power tools. Check for misalignment or binding of moving parts, breakage of parts and any other condition that may affect the power tool's operation. If damaged, have the power tool repaired before use. Many accidents are caused by poorly maintained power tools.

Keep cutting tools sharp and clean. Properly maintained cutting tools with sharp cutting edges are less likely to bind and are easier to control.

Use the power tool, accessories, and tool bits etc. in accordance with these instructions, taking into account the working conditions and the work to be performed. Use of the power tool for operations different from those intended could result in a hazardous situation.

Hold power tool by insulated gripping surfaces, when performing an operation where the fastener may contact hidden wiring or its own cord. Fasteners contacting a "live" wire may make exposed metal parts of the power tool "live" and could give the operator an electric shock.

BATTERY TOOL USE AND CARE

Recharge only with the charger specified by the manufacturer. A charger that is suitable for one type of battery pack may create a risk of fire when used with another battery pack.

Use power tools only with specifically designated battery packs. Use of any

other battery packs may create a risk of injury and fire.

When battery pack is not in use, keep it away from other metal objects, like paper clips, coins, keys, nails, screws, or other small metal objects that can make a connection from one terminal to another. Shorting the battery terminals together may cause burns or a fire.

Under abusive conditions, liquid may be ejected from the battery; avoid contact. If contact accidentally occurs, flush with water. If liquid contacts eyes, additionally seek medical help. Liquid ejected from the battery may cause irritation or burns.

SERVICE

Have your power tool serviced by a qualified repair person using only identical replacement parts. This will ensure that the safety of the power tool is maintained.

SPECIFIC SAFETY RULES

WARNING:

Know your cordless drill. Do not plug in the charger or install the battery in the tool until you have read and understand this Instruction Manual. Learn the tool's applications and limitations, as well as the specific potential hazards related to this tool. Following this rule will reduce the risk of electric shock, fire, or serious injury.



Always wear eye protection. Any power tool can throw foreign objects into your eyes and cause permanent eye damage. ALWAYS wear safety goggles (not glasses) that comply with ANSI safety standard Z87.1. Everyday glasses have only impact resistant lenses. They ARE NOT safety glasses.

WARNING:

Glasses or goggles not in compliance with ANSI Z87.1 could cause serious injury when they break.

WARNING:

Always use a safety shield, hearing protection and dust mask when drilling concrete.

WARNING:

To avoid fire or toxic reaction, never use gasoline, naphtha, acetone, lacquer thinner or similar highly volatile solvents to clean the tool.

WARNING:

Use only accessories that are recommended for this cordless drill. Follow the instructions that accompany the accessories. The use of improper accessories may result in injury.

 **WARNING:** If any part is missing or damaged, do not plug the tool into the power source or install any accessory until the missing or damaged part is replaced.

Do not drill material too small to be securely held.

Always keep hands out of the path of the drill bit. Avoid awkward hand positions where a sudden slip could cause your hand to move into the path of the drill bit.

Secure the workpiece. Use clamps or a vice to hold the workpiece. It is safer than using your hand and it frees both hands to operate the tool.

Make sure there are no nails or foreign objects in the part of the workpiece to be drilled.

To avoid injury from accidental starting, always remove the battery from the tool before installing or removing a drill bit.

Do not install or use any drill bit that exceeds 7" (17.5 cm) in length or extends more than 6" (15 cm) beyond the chuck jaws. They can bend or break suddenly.

Before starting the operation, jog the drill switch to make sure the drill bit does not wobble or vibrate.

Do not use fly cutters or multiple-part hole cutters, because they can come apart or become unbalanced during use.

Make sure the spindle has come to a complete stop before touching the chuck or attempting to change the drill bit.

Always make sure the chuck is tight and the drill bit firmly tightened in the chuck before starting drill.

BATTERY & CHARGER SAFETY

WARNING:

Only use the charger supplied with this kit to charge the 20V Li-ion batteries for this tool. Charging any other batteries may damage the charger and possibly cause serious injury.

Do not store or carry the battery in a manner in which metal objects could contact the exposed metal end. Do not place the battery in aprons, pockets, drawers, etc. with loose nails, screws, keys etc. The battery could short circuit causing a fire, personal injury, or damage to the battery.

Never attempt to open the battery for any reason. If the housing of the battery breaks or cracks, immediately discontinue use and do not recharge.

Do not charge the battery if it is wet or shows any evidence of corrosion.

A small leakage from the battery may occur under extreme usage, charging or temperature conditions. This does not indicate a failure. However, if the outer seal is broken and this leakage gets on your skin, follow these steps:

1. Wash immediately with soap and water.
2. Neutralize with a mild acid such as lemon juice or vinegar.
3. If liquid gets into your eyes, flush immediately with clean water for a minimum of 10 minutes and seek medical attention.

NOTE: The battery liquid is slightly acidic.

Do not incinerate the battery. It can explode in a fire.

Do not use an extension cord. Plug the charger cord directly into an electrical outlet.

Use the charger only in a standard 120V, 60 Hz electrical outlet.

Do not use the charger in wet or damp conditions. It is intended for indoor use only.

Do not use the charger near sinks or tubs. Do not immerse the charger in water.

Do not allow the cord to hang over the edge of a table or counter or touch hot surfaces.

The charger should be placed away from sinks and hot surfaces.

Do not use the charger to charge any batteries other than the cordless drill batteries. Other batteries may explode.

Do not allow the cord to hang over the edge of a table or counter or touch hot

surfaces. The charger should be placed away from sinks and hot surfaces.

Do not operate charger if the cord or plug is damaged. Replace the damaged cord and plug immediately.

Do not operate the charger if it has received a sharp blow, been dropped or otherwise damaged in any way. Have a qualified technician examine the charger and repair it if necessary. Do not disassemble the charger.

Do NOT charge the batteries when the work area or the battery temperature is at or below 5° C (41° F) or above 40.5° C (105° F).

Unplug the charger when not in use and before cleaning or maintenance.

BATTERY PACK RECYCLING











To preserve our natural resources, please recycle or dispose of batteries properly.

The batteries charged by this charger may contain chemicals and metals that are harmful to the environment. Never dispose of re-chargeable batteries in your normal household garbage or in landfill sites as they will add to the pollution of the environment.



SYMBOLS

⚠️ WARNING: Some of the following symbols may appear on the drill. Study these symbols and learn their meaning. Proper interpretation of these symbols will allow for more efficient and safer operation of this tool.

V	Volts		Three-phase alternating current
A	Amperes		Three-phase alternating current with neutral
Hz	Hertz		direct current
W	Watts	n_0	No load speed
kW	Kilowatts		Alternating or direct current
μF	Microfarads		Class II Construction
L	Liters		Splash-proof construction
kg	Kilograms		Watertight construction
H	Hours		Protective grounding at terminal, Class I tools
N/cm ²	Newtons per square centimetre	.../min	Revolutions or reciprocations per minute
Pa	Pascals	\emptyset	Diameter
OPM	Oscillation per minute	0	Off position
Min	Minutes		Directional Arrow
S	Seconds		Warning symbol
~ or AC	Alternating current		Wear safety glasses, hearing protection and dust mask



JD6318H20

This symbol designates that this tool is listed with U.S. and Canadian requirements by cTUVus Testing Laboratories, Inc. UL62841-1, UL62841-2-1 CSA C22.2#UL62841-1, UL62841-2-1

KNOW YOUR CORDLESS 20V MAX 2VSR DRILL



Battery Charger
5350-010



ASSEMBLY AND OPERATING

CHECKING THE BATTERY CHARGE STATUS

The level of charge remaining in the battery can be checked by using the battery LED power indicator that is contained on the end of the battery.

NOTE: The battery charge remaining may be checked while the battery is installed in the tool with the ON/OFF switch turned OFF. It may also be checked while the battery is removed from the tool. DO NOT check the battery charge remaining while the battery is in the charger.

NOTE: The battery charge remaining may be checked while the battery is installed in the tool with the ON/OFF switch turned OFF. It may also be checked while the battery is removed from the tool. DO NOT check the battery charge remaining while the battery is in the charger.



You will get a false reading and you may also damage the battery status system.

1. Press and hold the battery status button located on the end of the battery.
2. One or more of the Four LED lights in the LED window will come ON to indicate the amount of charge that is remaining in the battery as follows:

Charge level indicator				
Amount of charge remaining	10-25%	25-50%	50-75%	75-100%

3. Release the battery status button to turn the LED's OFF.

CHARGING THE BATTERY PACK

1. Place the battery charger (1) in a dry location near a 110–120V 60 Hz electrical outlet (Fig. 1).
2. Plug the battery charger into the outlet and make sure the green LED indicator light (5) comes ON. If it does not, refer to the chart (Fig. 2) to identify the problem.
3. Turn the battery (2) upside down and slide it onto the charger.



Fig. 1

NOTE: Make sure the grooves (3) in the sides of the battery slide over the matching tabs on the charger (4) until the battery latch “clicks” into place.

NOTES:

- When the charger is plugged into the wall receptacle and NO battery is on the charger, the green indicator light (5) will turn ON indicating the charger is “live”.
- When a discharged battery is installed on the charger, the green indicator light will turn OFF and the red indicator light (6) will FLASH. The flashing red indicator light indicates the battery is being charged.
- If the red indicator light does not come ON, check to make sure battery pack is slid fully onto the charger and the electrical outlet is working properly.
- See Fig. 2 at right for other indicator light functions.
- A discharged battery pack should be fully charged in up to 75 minutes.
- It is normal for the battery charger to hum and be warm to the touch during operation.
- If the battery pack does not charge properly, check to make sure the electrical outlet is “live”.
- Do NOT charge batteries when the work area or the battery temperature is at or below 5°C (41° F) or above 40°C (105° F).

GREEN LIGHT	RED LIGHT	BATTERY INSERTED INTO CHARGER	CHARGING STATUS
ON	OFF	NO	Charger connected to power supply
OFF	Blink	YES	Battery being charged
ON	OFF	YES	Battery fully charged
OFF	ON	YES	Battery is charged but not operational on tool. This may indicate defective / bad contact on battery.
ON	ON	YES	Charging conditions are either too hot or too cold

Fig. 2

INSTALLING A BATTERY ON THE DRILL

- Remove the discharged battery (1) from the drill by pressing downward on the battery release button (2) and sliding the battery backward until it is removed from the drill handle (3) (Fig. 3).
- Slide the fully charged battery onto the matching keys (4) in the drill handle where the discharged battery has been removed.

NOTE: Make sure the slots in the battery are fully engaged with the mounting keys in the drill handle. The battery release button will “click” into place when the battery is fully installed.

⚠ WARNING: Do not immerse the battery pack in water. Sudden cooling could cause a hot battery to explode or leak.

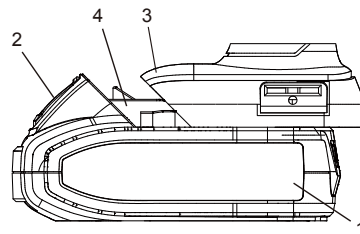



Fig. 3

ADJUSTING THE TORQUE

Your drill is equipped with an adjustable torque clutch for driving different types of screws into different types of materials. It also has a setting for "drilling". The proper setting depends upon the type of material, the size of screw being used, and the function required.

Adjust the torque setting as follows:

1. Identify the torque settings located on the torque adjustment ring (1) (Fig. 4).
2. Rotate adjustment ring to align the correct torque setting number with the torque indicator arrow (2). See the chart below for the correct torque settings.
 - 1–4 For driving small screws.
 - 5–7 For driving medium sized screws into soft materials.
 - 8–10 For driving screws into soft & medium-density materials.
 - 11–13 For driving screws into hardwood.
 - 14–16 For driving large screws.
 -  For drilling. This position is marked with a drill bit icon (3) on the torque adjustment ring (Fig. 5).

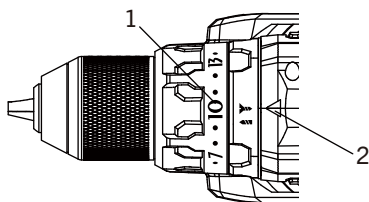

Fig. 4

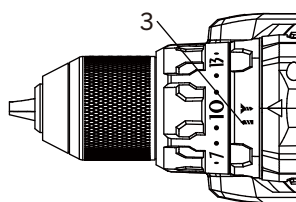

Fig. 5

FORWARD/REVERSE SWITCH

The forward/reverse switch (1) is conveniently mounted above the trigger switch (2) (Fig. 6). To make the drill rotate clockwise (for drilling) push the forward/reverse switch to the left. To make the drill rotate counter clockwise for removing screws, push the forward/reverse switch to the right.

NOTES:

- Never change the position of the forward/reverse switch while the chuck is turning.
- The trigger switch will NOT function with the forward/reverse switch in the middle position.

VARIABLE-SPEED TRIGGER SWITCH

This drill is equipped with a variable-speed ON/OFF trigger switch.

1. To start drill, gently squeeze the trigger switch (2) (Fig. 7).

NOTE: The drill will turn at its slowest speed when the trigger switch is depressed slightly. The drill will turn at its fastest speed when the trigger switch is fully depressed.

2. To stop the drill, release the trigger switch.

NOTE: Drilling at a slow speed for an extended period of time may cause the drill motor or the battery pack to overheat. If either the drill or the battery gets hot, stop drilling and allow them to cool for at least 15 minutes.

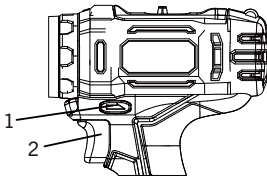

Fig. 6

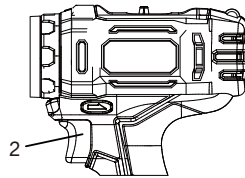

Fig. 7

LED WORK LIGHT

The LED work light (3) will automatically turn ON when the trigger switch is squeezed (Fig. 8). It will automatically turn OFF when the trigger switch is released.

NOTE: The LED light has a 10 second time delay.

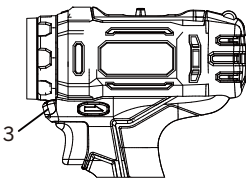

Fig. 8

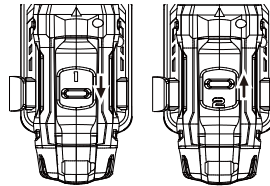

Fig. 9a

Fig. 9b

TWO-SPEED GEAR BOX SWITCH

The two-speed gear box switch is located on the top of the drill housing. Set the speed-control switch to the desired speed before starting the drill. Slide the speed-control switch FORWARD.

(Fig. 9a) for low-speed operation. Slide the speed control-switch BACK (Fig. 9b) for high-speed operation.

NOTES:

- Use low-speed setting for drilling large holes and for driving screws.
- Use high-speed setting for drilling smaller holes.
- Do NOT change the speed-control switch position while drill is turned ON. Damage to the gears may result.

INSTALLING DRILL BITS

⚠ WARNING: Never hold the chuck body with one hand and use the drill power to rotate the drill body to loosen or tighten bits. Serious injury may result.

This drill is equipped with a double sleeve keyless chuck.

1. To open the keyless drill chuck, grasp and hold the chuck collar (1) with one hand (Fig. 10). Rotate the chuck body (2) with the other hand in a counterclockwise direction (3) until the chuck jaws (4) open wide enough to accept the bit (5).
2. Insert the bit into the chuck the full length of the jaws. Raise the front of your drill slightly to prevent the bit from falling out of the chuck jaws.
3. Tighten the chuck jaws onto the bit by turning the chuck body in a clockwise direction. NOTE: Make sure the bit is properly aligned in the jaws and NOT at an angle. An improperly aligned bit could be thrown from the chuck when drill is started. Make sure flat sides of the screwdriver bit are being grasped by the chuck jaws.
4. Finish tightening the chuck jaws by holding the chuck collar with one hand and firmly tightening the chuck body by rotating it in a clockwise direction.

NOTE: Hand tighten the chuck jaws. Do NOT use pliers. You will damage the chuck.

⚠ WARNING: Do not insert the drill bit into the chuck and tighten as shown in Fig. 11. The drill bit MUST be properly inserted with all three of the chuck jaws holding the bit centered in the chuck. Failure to properly insert the drill bit could cause the drill bit to be thrown from the chuck, resulting in possible serious injury or damage to the chuck.

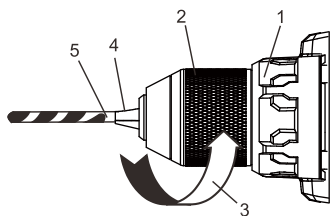

Fig. 10

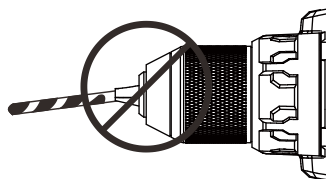

Fig. 11

REMOVING BITS

1. To open the keyless drill chuck, grasp and hold the chuck body and rotate it in a counterclockwise direction until the chuck jaws open wide enough to release the bit.
2. Remove the drill bit.

⚠️ WARNING: For safety reasons, the operator must read the sections of this Owner's Manual entitled "GENERAL SAFETY WARNINGS", "POWER TOOL SAFETY", "SPECIFIC SAFETY RULES", "BATTERY & CHARGER SAFETY" and "SYMBOLS" before using this cordless drill.

Verify the following every time the cordless drill is used:

1. Safety glasses, safety goggles, or face shield is being worn.
2. Hearing protection is being worn.
3. The chuck has not worked loose on the spindle.
4. The bit is in good condition and is properly tightened onto the chuck.

Failure to observe these safety rules will significantly increase the risk of injury.

DRILLING

When drilling into smooth, hard surfaces such as metal, use a center punch to mark the desired hole location. This will prevent the drill bit from slipping off center as the hole is started.

The workpiece to be drilled should be secured in a vice or with clamps to keep it from turning as the drill bit rotates (Fig. 12).

1. Check the drill bit to make sure it is firmly locked into the drill chuck and verify that the forward/reverse switch is in the forward position.
2. Set the torque clutch to the drilling position.
3. Hold the drill firmly with both hands whenever possible. Use one hand to grasp the handle and switch.

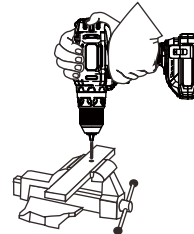

Fig. 12

NOTE: Make sure the hand placed on the body of the drill does not cover the air vents. Covering these air vents will reduce motor cooling, and possibly lead to overheating the motor.

4. While holding the drill firmly, place the point of the drill bit at the point to be drilled. Squeeze the switch trigger to start the drill.

NOTES: Always use a higher drill speed when drilling small holes. Use a slower drill speed when drilling large holes.

5. Move the drill bit into the workpiece applying only enough pressure to keep the bit cutting. Do not force the drill bit or apply sideways pressure to elongate the hole.

⚠️ WARNING: Be prepared for binding and bit breakthrough. When these situations occur, the drill bit has a tendency to grab the workpiece. This action will kick the drill opposite to the direction of the drill bit rotation and could cause loss of control when breaking through material as you complete drilling the hole. If you are not prepared, this loss of control can result in serious injury.

When drilling metals, use light oil on the drill bit to keep it from overheating. The oil will prolong the life of the drill bit and improve the cutting action. If the bit jams in the workpiece, or if the drill stalls, release the trigger switch immediately. Remove the bit from the workpiece and determine the reason for jamming.

DRIVING SCREWS

When driving screws, care must be taken to use the bit that correctly fits the screw being driven. Make sure you use the largest bit size that will properly fit into the head of the screw.

1. Select the correct screwdriver bit for the screw being driven.
2. Fasten the screwdriver bit into the chuck, making sure the flat sides of the bit are gripped by the chuck jaws.
3. Set the torque clutch to the appropriate setting, based on the chart on Page 12.

NOTE: If the workpiece material is particularly soft or porous, set the torque clutch to a lower setting to avoid overdriving the screw.

4. If the screw is driven too far into the workpiece before the clutch releases, set the clutch to a lower setting, and do not pull the trigger switch fully back. If the screw is not driven far enough into the workpiece, set the clutch to a higher setting.

NOTE: Do not continue to drive the screw once the clutch has released. This causes unnecessary wear of the clutch.

REMOVING THE CHUCK

1. Remove the battery pack from the drill.
2. Insert a 5/16" (8 mm) or larger hex key (1) into the chuck (2) and tighten the chuck jaws securely (Fig. 13). Make sure each of the chuck jaws (3) is seated on the flat surfaces of the hex key.
3. Tap the hex key sharply with a mallet (4) in a CLOCKWISE direction. This action will loosen the screw in the chuck for easy removal.
4. Open chuck jaws and remove the hex key.
5. Open the chuck jaws as far as possible.
6. Remove the chuck screw using a #2 \oplus screwdriver (Fig. 14). NOTE: Turn the screw CLOCKWISE to remove it. This screw has a left-handed thread.
7. Insert the hex key into the chuck and tighten jaws of chuck securely (Fig. 15). Tap the hex key sharply with a mallet in a COUNTER-CLOCKWISE direction. This will loosen the chuck on the spindle. The chuck can now be unscrewed and removed from the spindle by hand.

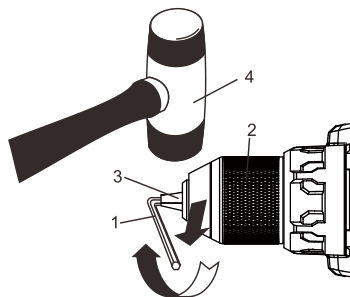

Fig. 13

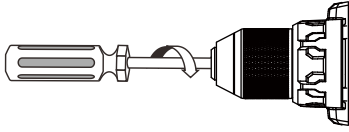

Fig. 14

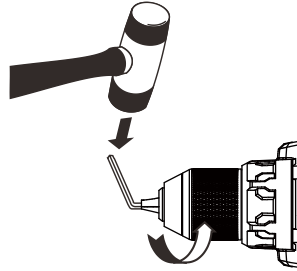

Fig. 15

RETIGHTENING A LOOSE CHUCK

1. Remove the battery pack from the drill.
2. Insert a 5/16" (8 mm) or larger hex key (1) into the chuck (2) and tighten the chuck jaws securely (Fig. 16). Make sure each of the chuck jaws (3) is seated on the flat surfaces of the hex key.
3. Tap the hex key sharply with a mallet (4) in a CLOCKWISE direction. This action will loosen the screw in the chuck for easy removal.
4. Open the chuck jaws and remove the hex key.
5. Tighten the chuck screw using a #2 \oplus screwdriver (Fig 14).

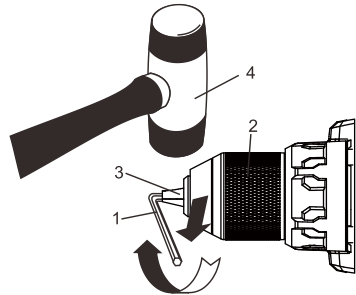

Fig. 16

NOTE: Turn the screw COUNTER-CLOCKWISE to tighten it. This screw has a left-handed thread.

MAINTENANCE

GENERAL

⚠️ WARNING: When servicing, use only identical replacement parts. The use of any other part may create a hazard or cause product damage.

DO NOT use solvents when cleaning plastic parts. Plastics are susceptible to damage from various types of commercial solvents and may be damaged by their use. Use a clean cloth to remove dirt, dust, oil, grease etc.

⚠️ WARNING: Do not allow brake fluids, gasoline, petroleum-based products, penetrating oils, etc. to come into contact with plastic parts. They contain chemicals that can damage, weaken, or destroy plastic.

DO NOT abuse power tools. Abusive practices can damage the tool and the workpiece.

⚠️ WARNING: DO NOT attempt to modify tools or create accessories. Any such alteration or modification is misuse and could result in a hazardous condition leading to possible serious injury. It will also void the warranty.

LUBRICATION

All of the bearings in this tool are lubricated with a sufficient amount of high-grade lubricant for the life of the unit under normal conditions. Therefore, no further lubrication is required.

BATTERY PACK REMOVAL AND PREPARATION FOR RECYCLING

To preserve our natural resources, please recycle or dispose of batteries properly.

The batteries accompanying this tool may contain chemicals and metals that are harmful to the environment. Never dispose of rechargeable batteries in your normal household garbage or in landfill sites because they will add to the pollution of the environment.

Consult your local waste authority for information regarding available recycling and disposal options.

⚠️ WARNING: Upon removal of the battery pack, cover the terminals of the battery pack with electrical tape or heavy-duty adhesive tape. Never touch both terminals with metal objects or body parts because a short circuit may result. Keep away from children. Do not attempt to destroy or disassemble battery pack or remove any of its components. Rechargeable batteries must be recycled or disposed of properly. Failure to comply with these warnings could result in fire and serious injury.

EXPLODED VIEW

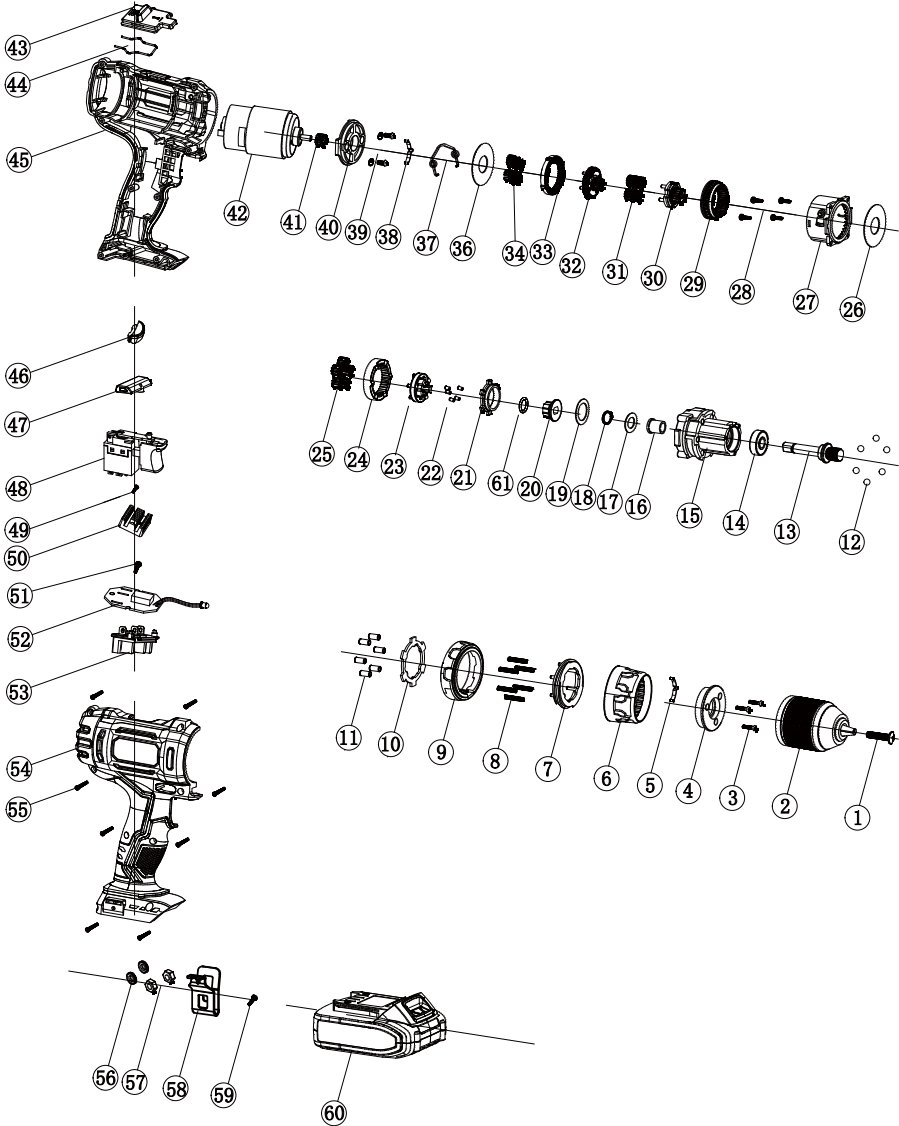

PARTS LIST

⚠ WARNING When servicing, use only original equipment replacement parts. The use of any other parts may create a safety hazard or cause damage to the tool. Any attempt to repair or replace electrical parts on this tool may create a safety hazard unless repairs are performed by a qualified technician. For more information, call the Toll-free Helpline, at 1-866-349-8665.

Always order by PART NUMBER, not by key number.

Key #	Part #	Part Name	Quantity
1	4020030020	Screw M6X18	1
2	1140050025	Chuck	1
3	4030010253	Screw ST2.9X14	3
4	2020210015	Plate	1
5	2050070071	Spring	1
6	3120080142	Collar clutch	1
7	3150190211	Ring	1
8	2050080150	Spring	6
9	3150190214	Ring	1
10	2030020383	Washer	1
11	4110040016	Needle $\phi 5 \times 11$	6
12	4080060001	Ball $\phi 5$	6
13	2040050174	Shaft	1
14	4010010038	Bearing 609 2Z	1
15	3150070108	Gear box	1
16	2010080127	Shaft coat	1
17	2030020101	Washer $\phi 14.8 \times \phi 9.2 T0.5$	1
18	4100020024	Washer 9	1
19	2030020214	Washer $\phi 25 \times \phi 17 T0.5$	1
20	2010230012	Driven plate	1
21	2010240034	Fixing ring	1
22	4110020003	Needle $\phi 3 \times 4.8$	6
23	1170070098	Planet assembly 3	1
24	2010090086	Ring	1
25	2010010139	Planet gear	5
26	2030020023	Washer $\phi 40 \times \phi 18 T0.5$	1
27	3150080024	Gear box	1
28	4030010003	Screw ST2.9X12	4
29	2010090085	Ring	1

Key #	Part #	Part Name	Quantity
30	1170070097	Planet assembly 2	1
31	2010010109	Planet gear	4
32	1170070096	Planet assembly 1	1
33	2010090071	Ring	1
34	2010010108	First planetary gear	4
35			
36	2030020242	Washer $\varnothing 38 \times \varnothing 15 T 0.5$	1
37	2050080180	Speed hook	1
38	2050070071	Spring	1
39	4020010143	Screw M4*8 with washer	2
40	3150090059	Flange	1
41	2010180057	Motor gear	1
42	1030070032	Motor	1
43	3120120147	Speed control board	1
44	2050080208	Wire	1
45	3010010201	Housing I	1
46	3160060105	Led cover	1
47	3120030144	Forward and reverse button	1
48	1060050017	Switch	1
49	4020010027	Screw M3*6	1
50	2020180023	Cooling block	1
51	4030010023	Screw M3*8	1
52	1130030101	PCB	1
53	3150170023	Electrode plate	1
54	3010010201	Housing II	1
55	4030010253	Screw ST2.9X14	8
56	4040080003	Washer	2
57	4060010039	Nut M3	2
58	2030100069	Hook	1
59	4020010168	Screw M3*12	1
60	1290090020	Battery	1

WARRANTY

BENCHMARK 20V MAX 2VSR DRILL WARRANTY

If this Benchmark tool fails due to a defect in material or workmanship within five years from the date of purchase, return it to any Home Hardware store with the original bill of sale for exchange. 3-year warranty for the battery and charger. This warranty does not include expendable parts including but not limited to blades, brushes, belts, light bulbs.

This warranty covers defects in material or workmanship only. It does not cover normal wear and tear, failure due to abuse/misuse, or defects caused by careless or accidental mishandling. If this Benchmark product is used for commercial or rental purposes, this warranty does not apply.

20V MAX 1/2" DRILL



5 year limited warranty on tool
3 year limited warranty on battery and charger

BENCHMARKTM_{MC}

BENCHMARK TOOLS CANADA
ST. JACOBS, ONTARIO N0B 2N0

© 2021 Home Hardware Stores Limited

CUSTOMER SERVICE/TECH SUPPORT
1-866-349-8665

1239-103

Made in China



* This BenchmarkTM product carries a five (5) year LIMITED warranty against defects in workmanship and materials. The charger and batteries carry a three (3) year LIMITED warranty. See Owner's Manual for full details.



JD6318H20

**READ ALL INSTRUCTIONS BEFORE FIRST USE.
KEEP THIS MANUAL FOR FUTURE REFERENCE.
KEEP AWAY FROM CHILDREN.**

Maximum initial battery voltage (measured without a load)
is 20 volts. Nominal voltage is 18 volts.



**WEAR CSA APPROVED
EYE PROTECTION**



**WEAR EAR
PROTECTION**



**WEAR A
FACE MASK**

BENCHMARKTM MC

20V MAX IMPACT DRIVER



5 Year Limited Warranty
3 Year Limited Warranty on Battery and Charger
Battery & charger included where applicable



JD509920

**READ ALL INSTRUCTIONS BEFORE FIRST USE.
KEEP THIS MANUAL FOR FUTURE REFERENCE.
KEEP AWAY FROM CHILDREN.**

Maximum initial battery voltage (measured without a load)
is 20 volts. Nominal voltage is 18 volts.



**WEAR CSA APPROVED
EYE PROTECTION**



**WEAR EAR
PROTECTION**



**WEAR A
FACE MASK**

PRODUCT SPECIFICATIONS

20V MAX IMPACT DRIVER	
Variable Speed	0–3,000 RPM (no load)
Impact Speed	0–3,000 BPM
Torque	1,800 in/lbs (203 Nm) maximum
Hex drive	Quick release 1/4" (6.35 mm)
Weight	3.5lbs (1.16kg)
Battery	20V 2.5Ah Max* Li-ion (Maximum charged battery voltage, measured without load, is 20V with a nominal value of 18V)
Replacement Battery	5350-023 (2.5Ah)
Replacement Charger Assembly	5350-010 (2.4A) up to 75minutes charge time

NEED ASSISTANCE?

Call us on our toll-free customer support line:

1-866-349-8665 (Monday through Friday 9am – 5pm Eastern Standard Time)

- Technical questions
- Replacement parts
- Parts missing from package





TABLE OF CONTENTS

Product Specifications	1
Table of Contents	2
General Safety Instructions	3
Eye, Ear & Lung Protection	3
Electrical Safety	4
Power Tool Safety	4
Work Area Safety	4
Electrical Safety	4
Personal Safety	5
Power Tool Use and Care	5
Battery Tool Use and Care	6
Service	6
Specific Safety Rules	6
Battery & Charger Safety	8
Battery Pack Recycling	9
Symbols	10
Know Your 20V Max Impact Driver.....	11
Assembly and Operation	12
Checking the Battery Charge Status	12
Checking the Battery Pack	12
Installing a Battery in the Impact Driver.....	13
Installing Screwdriver Bits and Sockets	14
Forward/Reverse Switch.....	15
Variable-Speed Trigger Switch.....	15
LED Work Light	16
Preparing Screw Holes	16
Driving Screws.....	17
Installing Nut Drivers For 3/16" To 3/8" Nuts	18
Installing Impact Sockets For 7/16" to 3/4" Nuts	18
Removing Nuts	18-19
Maintenance	20
General	20
Lubrication	20
Lithium-ion Battery Performance	20
Lithium-ion Battery Maintenance	20
Battery Pack Removal and Preparation for Recycling.....	21
Exploded View	22
Parts List	23
Warranty	24

GENERAL SAFETY INSTRUCTIONS

⚠️ WARNING: Before using this tool or any of its accessories, read this manual and follow all Safety Rules and Operating Instructions. The important precautions, safeguards and instructions appearing in this manual are not meant to cover all possible situations. It must be understood that common sense and caution are factors which cannot be built into the product.

EYE, EAR & LUNG PROTECTION

SYMBOL	MEANING
<p data-bbox="114 511 288 544">⚠️ DANGER</p> 	<p data-bbox="317 519 946 565">ALWAYS WEAR EYE PROTECTION THAT CONFORMS WITH CSA Z94.3 or ANSI SAFETY STANDARD Z87.1</p> <p data-bbox="317 565 920 690">FLYING DEBRIS can cause permanent eye damage. Prescription eyeglasses ARE NOT a replacement for proper eye protection. The usage of a safety standard compliant face shield placed over proper safety glasses or goggles can reduce the risk of facial injury. Non-compliant eyewear can cause serious injury if broken during the operation of a power tool.</p>
<p data-bbox="114 722 288 755">⚠️ WARNING</p> 	<p data-bbox="317 755 909 795">Use hearing protection, particularly during extended periods of operation of the tool, or if the operation is noisy.</p>
<p data-bbox="114 852 288 885">⚠️ WARNING</p> 	<p data-bbox="317 852 734 909">WEAR A DUST MASK THAT IS DESIGNED TO BE USED WHEN OPERATING A POWER TOOL IN A DUSTY ENVIRONMENT.</p> <p data-bbox="317 917 920 974">Dust that is created by power sanding, sawing, grinding, drilling, and other construction activities may contain chemicals that are known to cause cancer, birth defects,</p> <p data-bbox="317 982 776 998">or other genetic abnormalities. These chemicals include:</p> <ul data-bbox="317 998 776 1079" style="list-style-type: none"> • Lead from lead-based paints • Crystalline silica from bricks, cement, and other masonry products • Arsenic and chromium from chemically treated lumber <p data-bbox="317 1088 952 1209">The level of risk from exposure to these chemicals varies, according to how often this type of work is performed. In order to reduce exposure to these chemicals, work in a well-ventilated area, and use approved safety equipment, such as a dust mask that is specifically designed to filter out microscopic particles.</p>
<p data-bbox="114 1242 288 1274">⚠️ WARNING</p> 	<p data-bbox="317 1226 808 1299">TO AVOID ELECTRICAL HAZARDS, FIRE HAZARDS OR DAMAGE TO THE TOOL, USE PROPER CIRCUIT PROTECTION.</p> <p data-bbox="317 1307 952 1388">This tool is wired at the factory for 120 V AC operation. It must be connected to a 120 V AC, 15 A circuit that is protected by a time-delayed fuse or circuit breaker. To avoid shock or fire, replace power cord immediately if it is worn, cut or damaged in any way.</p>

⚠ WARNING

WARNING: Ventilation openings in batteries and chargers must always be open to allow cooling air to circulate freely. Air vents that are blocked, restricted or covered may result in the battery or charger overheating. Overheating may lead to damage to the tool or cause a fire, resulting in possible serious injury.

POWER TOOL SAFETY

⚠ WARNING: Read all safety warnings and instructions. Failure to follow the warnings and instructions may result in electric shock, fire and/or serious injury.

Save all warnings and instructions for future reference.

WORK AREA SAFETY

Keep work area clean and well lit. Cluttered or dark areas invite accidents.

Do not operate power tools in explosive atmospheres, such as in the presence of flammable liquids, gases or dust. Power tools create sparks which may ignite the dust or fumes.

Keep children and bystanders away while operating a power tool. Distractions can cause you to lose control.

ELECTRICAL SAFETY

Power tool plugs must match the outlet. Never modify the plug in any way.

Do not use any adapter plugs with earthed (grounded) power tools. Unmodified plugs and matching outlets will reduce risk of electric shock.

Avoid body contact with earthed or grounded surfaces such as pipes, radiators, ranges and refrigerators. There is an increased risk of electric shock if your body is earthed or grounded.

Do not expose power tools to rain or wet conditions. Water entering a power tool will increase the risk of electric shock.

Do not abuse the cord. Never use the cord for carrying, pulling or unplugging the power tool. Keep cord away from heat, oil, sharp edges or moving parts. Damaged or entangled cords increase the risk of electric shock.

When operating a power tool outdoors, use an extension cord suitable for outdoor use. Use of a cord suitable for outdoor use reduces the risk of electric shock.

If operating a power tool in a damp location is unavoidable, use a residual current device (RCD) protected supply. Use of a ground fault circuit interrupter (GFCI) reduces the risk of electric shock.

PERSONAL SAFETY

Stay alert, watch what you are doing and use common sense when operating a power tool. Do not use a power tool while you are tired or under the influence of drugs, alcohol or medication. A moment of inattention while operating power tools may result in serious personal injury.

Use personal protective equipment. Always wear eye protection. Protective equipment such as dust mask, non-skid safety shoes, hard hat, or hearing protection used for appropriate conditions will reduce personal injuries.

Prevent unintentional starting. Ensure the switch is in the off-position before connecting to power source and/or battery pack, picking up or carrying the tool. Carrying power tools with your finger on the switch or energizing power tools that have the switch on invites accidents.

Remove any adjusting key or wrench before turning the power tool on.

A wrench or a key left attached to a rotating part of the power tool may result in personal injury.

Do not overreach. Keep proper footing and balance at all times. This enables better control of the power tool in unexpected situations.

Dress properly. Do not wear loose clothing or jewellery. Keep your hair, clothing and gloves away from moving parts. Loose clothes, jewellery or long hair can be caught in moving parts.

If devices are provided for the connection of dust extraction and collection facilities, ensure these are connected and properly used. Use of dust collection can reduce dust-related hazards.

POWER TOOL USE AND CARE

Do not force the power tool. Use the correct power tool for your application.

The correct power tool will do the job better and safer at the rate for which it was designed.

Do not use the power tool if the switch does not turn it on and off. Any power tool that cannot be controlled with the switch is dangerous and must be repaired.

Disconnect the plug from the power source and/or the battery pack from the power tool before making any adjustments, changing accessories, or storing power tools. Such preventive safety measures reduce the risk of starting the power tool accidentally.

Store idle power tools out of the reach of children and do not allow persons unfamiliar with the power tool or these instructions to operate the power tool.

Power tools are dangerous in the hands of untrained users.

Maintain power tools. Check for misalignment or binding of moving parts, breakage of parts and any other condition that may affect the power tool's operation. If damaged, have the power tool repaired before use. Many accidents are caused by poorly maintained power tools.

Keep cutting tools sharp and clean. Properly maintained cutting tools with sharp cutting edges are less likely to bind and are easier to control.

Use the power tool, accessories and tool bits etc. in accordance with these instructions, taking into account the working conditions and the work to be performed. Use of the power tool for operations different from those intended could result in a hazardous situation.

Hold power tool by insulated gripping surfaces when performing an operation where the cutting tool may contact hidden wiring or its own cord. Contact with a "live" wire will make exposed metal parts of the tool "live" and shock the operator.

Hold power tool by insulated gripping surfaces, when performing an operation where the fastener may contact hidden wiring or its own cord.

Fasteners contacting a “live” wire may make exposed metal parts of the power tool “live” and could give the operator an electric shock.

BATTERY TOOL USE AND CARE

Recharge only with the charger specified by the manufacturer. A charger that is suitable for one type of battery pack may create a risk of fire when used with another battery pack.

Use power tools only with specifically designated battery packs. Use of any other battery packs may create a risk of injury and fire.

When battery pack is not in use, keep it away from metal objects like paper clips, coins, keys, nails, screws, or other small metal objects that can make a connection from one terminal to another. Shorting the battery terminals together may cause burns or fire.

Under abusive conditions, liquids may be ejected from the battery; avoid contact. If contact accidentally occurs, flush with water. If liquid contacts eyes, additionally seek medical help. Liquid ejected from the battery may cause irritation or burns.

SERVICE

Have your power tool serviced by a qualified repair person using only identical replacement parts. This will ensure that the safety of the power tool is maintained.

SPECIFIC SAFETY RULES

 WARNING: Know your cordless impact driver. Do not plug in the charger or install the battery in the tool until you have read and understand this Instruction Manual. Learn the tool’s applications and limitations, as well as the specific potential hazards related to this tool. Following this rule will reduce the risk of electric shock, fire, or serious injury.



Always wear eye protection. Any power tool can throw foreign objects into your eyes and cause permanent eye damage. ALWAYS wear safety goggles (not glasses) that comply with ANSI safety standard Z87.1. Everyday glasses have only impact resistant lenses. They ARE NOT safety glasses.

 WARNING: Glasses or goggles not in compliance with ANSI Z87.1 could cause serious injury when they break.

 WARNING: Always use a safety shield, hearing protection and dust mask when drilling concrete.

 WARNING: To avoid fire or toxic reaction, never use gasoline, naphtha, acetone, lacquer thinner or similar highly volatile solvents to clean the tool.

 WARNING: Use only accessories that are recommended for this cordless drill. Follow the instructions that accompany the accessories. The use of improper accessories may result in injury to the operator or damage to the tool.

⚠️ WARNING: If any part is missing or damaged, do not plug the tool into the power source or install any accessory until the missing or damaged part is replaced.

Use impact sockets and accessories that are designed for use with an impact driver. Do not use chrome plated sockets and accessories. Chrome plated sockets and accessories are designed for hand use only and **MUST NOT** be used with an impact driver. They may shatter and possibly cause serious injury.

Before each use, check the impact sockets and accessories for excessive wear or cracks. Worn or damaged sockets or accessories may shatter and possibly cause serious injury. Worn accessories may allow the socket to come off during operation of the impact driver.

After installing any accessory in the hex drive, pull outward on the accessory to ensure it is properly installed and cannot be pulled out of the hex drive.

Never use the impact driver as a torque wrench. Always use a torque wrench to adjust the fastener to the specified torque.

Keep the impact driver handle and body clean and free of oil and grease. Always use a clean dry cloth when cleaning. Do not use solvents, brake fluid, gasoline or other petroleum products to clean the tool. They will damage the tool.

Do not wear neckties or loose clothing.

When wearing gloves, they must be tight fitting and slip resistant type. Leather gloves offer the best protection.

Always use two hands when operating the impact driver. Use one hand on the handle and the other on the front of the tool body.

Never place your hand so it is touching the nut driver or accessory when the tool is turned ON. Your hand could be seriously injured.

Always remove the plug from the power source before installing or removing any socket or accessory.

Be ready for components to shift when removing any fastener. The speed of the fastener removal could cause unexpected shifting of the components.

BATTERY & CHARGER SAFETY

⚠️ WARNING: Only use the charger supplied with this kit to charge the 20V Max* Li-ion batteries for this tool. Charging any other batteries may damage the charger and possibly cause serious injury.

Do not store or carry the battery in a manner in which metal objects could contact the exposed metal end. Do not place the battery in aprons, pockets, drawers, etc. with loose nails, screws, keys etc. The battery could short circuit causing a fire, personal injury, or damage to the battery.

Never attempt to open the battery for any reason. If the housing of the battery breaks or cracks, immediately discontinue use and do not recharge.

Do not charge the battery if it is wet or shows any evidence of corrosion.

A small leakage from the battery may occur under extreme usage, charging or temperature conditions. This does not indicate a failure. However, if the outer seal is broken and this leakage gets on your skin, follow these steps:

1. Wash immediately with soap and water.
2. Neutralize with a mild acid such as lemon juice or vinegar.
3. If liquid gets into your eyes, flush immediately with clean water for a minimum of 10 minutes and seek medical attention.

NOTE: The battery liquid is slightly acidic.

Do not incinerate the battery. It can explode in a fire.

Do not use an extension cord. Plug the charger cord directly into an electrical outlet.

Use the charger only in a standard 120V, 60 Hz electrical outlet.

Do not use the charger in wet or damp conditions. It is intended for indoor use only. Do not use the charger near sinks or tubs. Do not immerse the charger in water. Do not allow the cord to hang over the edge of a table or counter or touch hot surfaces.

The charger should be placed away from sinks and hot surfaces.

Do not use the charger to charge any batteries other than the cordless drill batteries. Other batteries may explode.

Do not allow the cord to hang over the edge of a table or counter or touch hot surfaces. The charger should be placed away from sinks and hot surfaces.

Do not operate charger if the cord or plug is damaged. Replace the damaged cord and plug immediately.

Do not operate the charger if it has received a sharp blow, been dropped or otherwise damaged in any way. Have a qualified technician examine the charger and repair it if necessary. Do not disassemble the charger.

Do NOT charge the batteries when the work area or the battery temperature is at or below 0° C (32° F) or above 45° C (113° F).

Unplug the charger when not in use and before cleaning or maintenance.

BATTERY PACK RECYCLING











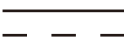



To preserve our natural resources, please recycle or dispose of batteries properly.

The batteries charged by this charger may contain chemicals and metals that are harmful to the environment. Never dispose of re-chargeable batteries in your normal household garbage or in landfill sites as they will add to the pollution of the environment.

SYMBOLS

⚠️ WARNING: Some of the following symbols may appear on the impact driver. Study these symbols and learn their meaning. Proper interpretation of these symbols will allow for more efficient and safer operation of this tool.

V	VOLTS		Three-phase alternating current with neutral
A	Amperes		Direct current
Hz	Hertz	n₀	No load speed
W	Watts		Alternating or direct current
kW	Kilowatts		Class II construction
µF	Microfarads		Splash-proof construction
L	Liters		Watertight construction
kg	Kilograms		Protective grounding at grounding terminal, Class I tools
H	Hours	.../min	Revolutions or reciprocations per minute
N/cm²	Newtons per square centimeter	∅	Diameter
Pa	Pascals	0	Off position
OPM	Oscillations per minute		Arrow
MIN	Minutes		Warning symbol
S	Seconds		Wear your safety glasses
 or ac.	Alternating current		Wear a dust mask
 3	Three-phase alternating current		Wear hearing protection



This symbol designates that this tool is listed with U.S. and Canadian requirements by cTUVus Testing Laboratories, Inc.
 UL62841-1, UL62841-2-2;
 CSA C22.2#62841-1, CSA C22.2#62841-2-2.

KNOW YOUR 20V MAX IMPACT DRIVER

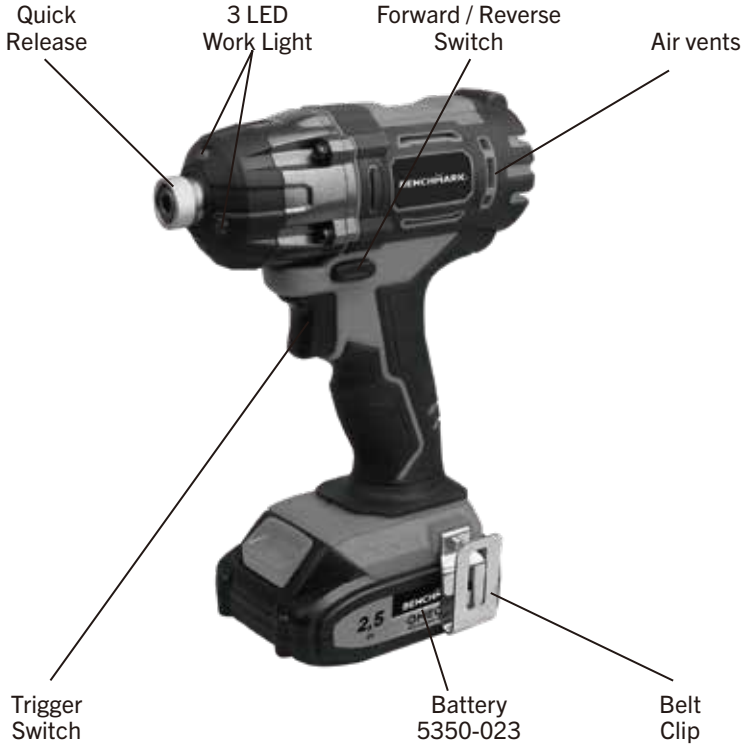

Battery charger
5350-010



ASSEMBLY AND OPERATION

CHECKING THE BATTERY CHARGE STATUS

The level of charge remaining in the battery can be checked by using the battery LED power indicator that is contained on the end of the battery.

NOTE: The battery charge remaining may be checked while the battery is installed in the tool with the ON/OFF switch turned OFF. It may also be checked while the battery is removed from the tool. **DO NOT** check the battery charge remaining while the battery is in the charger. You will get a false reading and you may also damage the battery status system.

1. Press and hold the battery status button located on the end of the battery.
2. One or more of the Four LED lights in the LED window will come ON to indicate the amount of charge that is remaining in the battery as follows:

Charge Level Indicator						
Amount of Charge Remaining	0 - 10%	10 - 25%	25 - 50%	50 - 75%	75 - 100%	

3. Release the battery status button to turn the LEDs OFF.

CHECKING THE BATTERY PACK

1. Place the battery charger (1) in a dry location near a 110–120V 60 Hz electrical outlet (Fig. 1).
2. Plug the battery charger into the outlet and make sure the green LED indicator light (5) comes ON. If it does not, refer to the chart (Fig. 2) to identify the problem.
3. Turn the battery (2) upside down and slide it onto the charger. NOTE: Make sure the grooves (3) in the sides of the battery slide over the matching tabs on the charger (4) until the battery latch “clicks” into place.

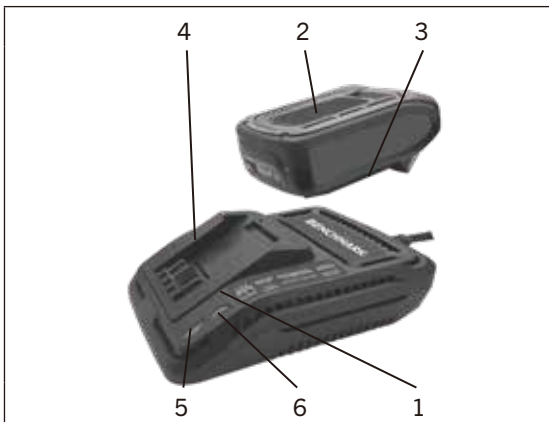

FIG. 1

- NOTE:** a) When the charger is plugged into the wall receptacle and NO battery is on the charger, the green indicator light (5) will turn ON indicating the charger is “live”.
- b) When a discharged battery is installed on the charger, the green indicator light will turn OFF and the red indicator light (6) will FLASH. The flashing red indicator light indicates the battery is being charged.
- c) If the red indicator light does not come ON, check to make sure battery pack is slid fully onto the charger and the electrical outlet is working properly.
- d) See Fig. 2 at right for other indicator light functions.
- e) A discharged battery pack should be fully charged in up to 75 minutes.
- f) It is normal for the battery charger to hum and be warm to the touch during operation.
- g) If the battery pack does not charge properly, check to make sure the electrical outlet is “live”.
- h) Do NOT charge batteries when the work area or the battery temperature is at or below 5°C (41° F) or above 40°C (105° F).

Green Light	Red Light	Battery Inserted Into Charger	Charging Status
ON	OFF	ON	Charger connected to power supply
OFF	Flashing	YES	Battery being charged
ON	OFF	YES	Battery fully charged
OFF	ON	YES	Battery defective or bad contact
ON	ON	YES	Battery too hot or too cold to be charged

FIG. 2

INSTALLING A BATTERY IN THE IMPACT DRIVER

1. Remove the discharged battery (1) from the impact driver by pressing downward on the battery release button (2) and sliding the battery backward until it is removed from the impact driver handle (3) (Fig. 3).
2. Slide the fully charged battery onto the matching keys (4) in the impact driver handle where the discharged battery has been removed.

NOTE: Make sure the slots in the battery are fully engaged with the mounting keys in the handle handle. The battery release button will “click” into place when the battery is fully installed.

⚠ WARNING: Do not immerse the battery pack in water. Sudden cooling could cause a hot battery to explode or leak.

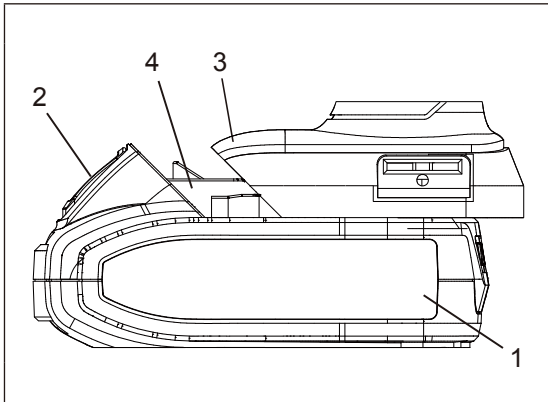

FIG. 3

INSTALLING SCREWDRIVER BITS AND SOCKETS

⚠ WARNING: Never hold the impact driver with your fingers near the switch while changing the screwdriver bits. Accidentally touching the switch may start the tool and possibly cause an injury.

⚠ WARNING: Use only screwdriver bits, sockets that are designed for use with an impact driver. Do not use chrome plated sockets and accessories. Chrome plated sockets and accessories are designed for hand use only and **MUST NOT** be used with an impact driver. They may shatter and possibly cause serious injury.

⚠ WARNING: Always remove the battery from the tool before changing any sockets, bits or accessories. You may injure your hand if the tool is started accidentally.

1. Pull outward on the quick release chuck (1) (Fig. 4).
2. Insert the grooved end of the impact driver bit holder. (2) into the chuck (3) of the tool.

NOTES: a) Always use ANSI single ended screwdriver bits or nut driver with the grooved end. These bits will be properly held in place by the chuck. Other bit types cannot be properly secured in the chuck. b) Push the screwdriver bit as far as it will go into the chuck.

3. Release the quick release chuck.
4. Pull outward on the screwdriver bit to ensure it is properly locked into the chuck.

NOTES: a) Use the largest size screwdriver bit that will properly fit the screw head. b) Make sure the screwdriver bit is in good condition and is neither damaged nor worn.

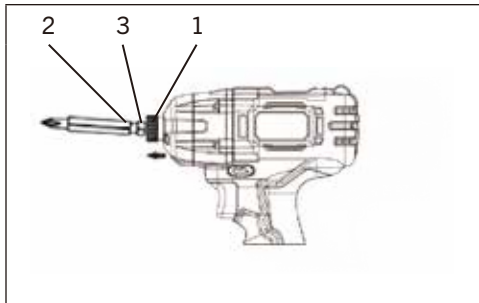

FIG. 4

FORWARD/REVERSE SWITCH

The forward/reverse switch (1) is conveniently mounted above the trigger switch (2) (Fig. 5). To make the impact driver rotate clockwise for driving screws, push the forward/reverse switch to the left. To make the driver rotate counter-clockwise for removing screws, push the forward/reverse switch to the right

NOTE: a) Never change the position of the forward/ reverse switch while the chuck is turning. b) The trigger switch will Not function with the forward/reverse switch in the middle position.

VARIABLE-SPEED TRIGGER SWITCH

This drill is equipped with a variable-speed ON/OFF trigger switch.

1. To start the impact driver, gently squeeze the trigger switch (2) (Fig. 6). **NOTE:** The impact driver will turn at its slowest speed when the trigger switch is squeezed lightly. The impact driver will turn at its fastest speed when the trigger switch is squeezed firmly.

2. To stop the drill, release the trigger switch.

NOTE: Operating the impact driver at a slow speed for an extended period of time may cause the impact driver motor or the battery to overheat. If the driver gets hot, stop operating it and allow it to cool for at least 15 minutes.

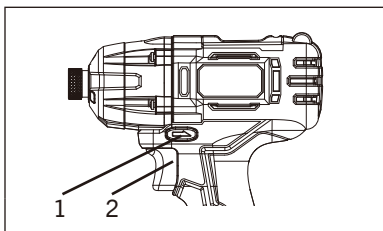

FIG. 5

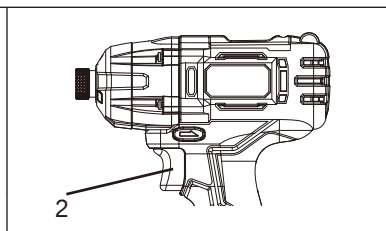
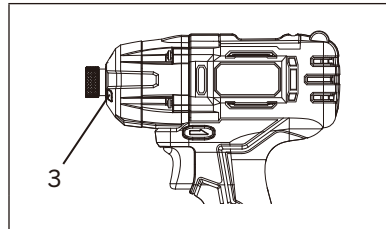

FIG. 6

LED WORK LIGHT

The LED work light (3) will automatically turn ON when the trigger switch is squeezed (Fig. 7). It will automatically turn OFF when the trigger switch is released.

NOTE: The LED light has a 20-second time delay.

**FIG. 7****PREPARING SCREW HOLES**

It is important to prepare screw holes before attempting to fasten two pieces of wood together. Proper preparation will make screws drive easier and prevent misaligned components, stripped screw heads, splitting and separating of wood components.

1. Clamp the components that are to be screwed together in their desired position (Fig. 8).
2. Drill a pilot hole (1) through the outer piece (2) and into the inner piece (3).
Drill hole 2/3 the diameter of the smooth portion of the screw shank.

NOTE: If the wood is soft, drill the hole 2/3 the length of the screw. If the wood is hard, drill the hole the full length of the screw.

3. Remove the clamp from the two pieces to be screwed together.
4. Enlarge the hole (1) in the outer piece (2) so it is the same size as the smooth portion of the screw shank (Fig. 9).
5. If using a flat head screw, counter-sink the hole (4) so the head of the screw will be flush with the surface when fully driven into place.

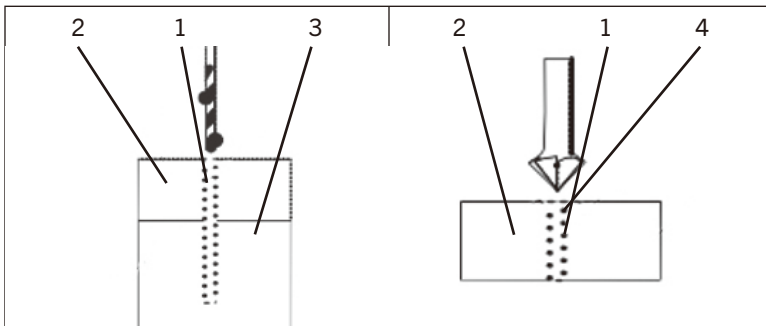
**FIG. 8****FIG. 9**

DRIVING SCREWS

When driving screws, care must be taken to use a bit that correctly fits the head of the screw being driven. Make sure you use the largest bit size that will properly fit into the head of the screw. The bits must also be in good condition and not worn so they will drive screws without slipping out of the screw head.

1. Select the correct screwdriver bit for the screw being driven and install it in the collet (Fig. 4).
2. Set forward/reverse switch to “forward” (Fig. 5).
3. Insert the screwdriver bit fully into the screw head (Fig. 10).
4. While holding the screwdriver bit firmly against the screw and the bit aligned with the screw, squeeze the trigger switch to start the cordless driver and drive the screw.
5. When the screw is driven to the correct depth, release the switch and the impact driver will stop.

NOTE: As the screw is driven into the wood, the torque required to completely drive the screw into the wood will increase. The impact function will allow you to continue driving the screw until it is fully nested in the countersunk area.

6. Release the trigger as soon as the screw is driven to the desired depth. Failure to release the trigger at this point will result in an overdriven screw and possibly twist the head off the screw.

NOTE: To remove screws, follow the same general procedure as for driving screws.

7. Push the forward/reverse button to the RIGHT for removing screws.
8. Insert the bit fully into the screw head.
9. Hold the impact driver and bit firmly against the screw head and squeeze the trigger switch.

NOTE: The impact action will allow you to remove tight screws.

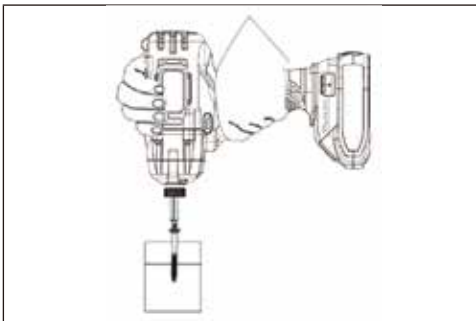

FIG. 10

This impact driver may be used with nut drivers and impact sockets. Although these accessories are NOT included with this tool, they may be purchased separately.

WARNING: Nut drivers, socket adaptor and sockets MUST be impact rated and include the ANSI locking groove.

INSTALLING NUT DRIVERS FOR 3/16" TO 3/8" NUTS

1. Select the correct nut driver size.
2. Insert the hex end (1) into the hex drive (2) (Fig. 11).

NOTE: See Fig. 3 for complete procedure.

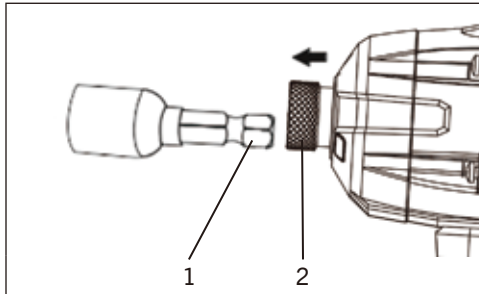

FIG. 11

INSTALLING IMPACT SOCKETS FOR 7/16" TO 3/4" NUTS

1. Insert the hex end of the socket adaptor (1) into the hex drive (2) (Fig. 12).
2. Select the correct socket size.
3. Push the square end of the socket (3) onto the matching square end of the adaptor (4).

NOTE: Make sure the socket is fully installed onto the square portion of the adaptor.

REMOVING NUTS

1. Press the forward/reverse button to the RIGHT for removing nuts (Fig. 5).
2. Place the socket fully onto the nut.
3. Hold the nut driver socket and impact driver firmly against the nut with both hands. With the nut driver aligned with the nut, squeeze the trigger switch to start the impact driver and remove the nut.

NOTE: When removing fasteners, do not allow the impact driver to operate more than 5 seconds unless the fastener begins to turn. If the fastener fails to turn within 5 seconds, reverse the direction of rotation and operate the impact driver in a forward direction on the fastener for a few seconds. Now switch back to reverse direction and remove the fastener. This procedure will usually break loose seized or “frozen” fasteners.

⚠ WARNING: Operating the impact driver for more than 5 seconds at a time on a seized or “frozen” fastener will place severe stress on the impact driver and cause damage. It may also break the fastener.

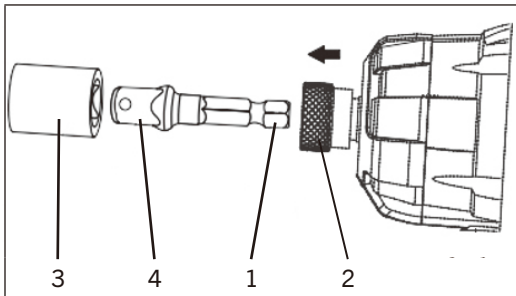

FIG. 12

MAINTENANCE

GENERAL

⚠️ WARNING: When servicing, use only identical replacement parts. The use of any other part may create a hazard or cause product damage.

DO NOT use solvents when cleaning plastic parts. Plastics are susceptible to damage from various types of commercial solvents and may be damaged by their use. Use a clean cloth to remove dirt, dust, oil, grease etc.

⚠️ WARNING: DO NOT allow brake fluids, gasoline, petroleum-based products, penetrating oils, etc. to come into contact with plastic parts. They contain chemicals that can damage, weaken, or destroy plastic.

DO NOT abuse power tools. Abusive practices can damage the tool and the workpiece.

⚠️ WARNING: DO NOT attempt to modify tools or create accessories. Any such alteration or modification is misuse and could result in a hazardous condition leading to possible serious injury. It will also void the warranty.

LUBRICATION

All of the bearings in this tool are lubricated with a sufficient amount of high-grade lubricant for the life of the unit under normal conditions. Therefore, no further lubrication is required.

LITHIUM-ION BATTERY PERFORMANCE

Lithium-ion rechargeable batteries generally provide superior performance to nickel-cadmium batteries when used in power tools.

- Faster charges
- Longer battery life
- More power
- Lighter weight

Lithium-ion batteries perform best and deliver peak output power at room temperature (20° C or 68° F). When operated in lower temperatures, the battery output will be reduced and it will NOT function below -20° C (-4° F). The output power will increase as the heat generated by the battery during use increases the internal temperature of the battery. The result is increased power as the tool is used.

LITHIUM-ION BATTERY MAINTENANCE

Lithium-ion batteries share many characteristics with nickel-cadmium batteries.

The major characteristic that is NOT shared with nickel-cadmium batteries is that Lithium-ion batteries do not have a “memory” and do not require to be completely discharged periodically. It is recommended that you charge your Lithium-ion batteries after each use so they will be fully charged when needed.

NOTE: A fully charged battery will lose about 2% of its charge per month during storage.

BATTERY PACK REMOVAL AND PREPARATION FOR RECYCLING

To preserve our natural resources, please recycle or dispose of batteries properly.

The batteries supplied with this tool may contain chemicals and metals that are harmful to the environment. Never dispose of rechargeable batteries in your normal household garbage or land fill sites because they will add to the pollution of the environment.

Consult your local waste authority for information regarding available recycling and disposal options.

⚠️ WARNING: If the battery pack has been removed from the tool, cover the terminals of the battery pack with electrical tape or heavy-duty adhesive tape. Never touch both terminals with metal objects or body parts, because a short circuit may result. Keep away from children. Do not attempt to destroy or disassemble battery pack or remove any of its components. Rechargeable batteries must be recycled or disposed of properly. Failure to comply with these warnings could result in fire and serious injury.

⚠️ WARNING: When servicing, use only original equipment replacement parts. The use of any other parts may create a safety hazard or cause damage to the tool. Any attempt to repair or replace electrical parts on this tool may create a safety hazard unless repairs are performed by a qualified technician. For more information, call the Toll-free helpline at 1-866-349-8665.

EXPLODED VIEW

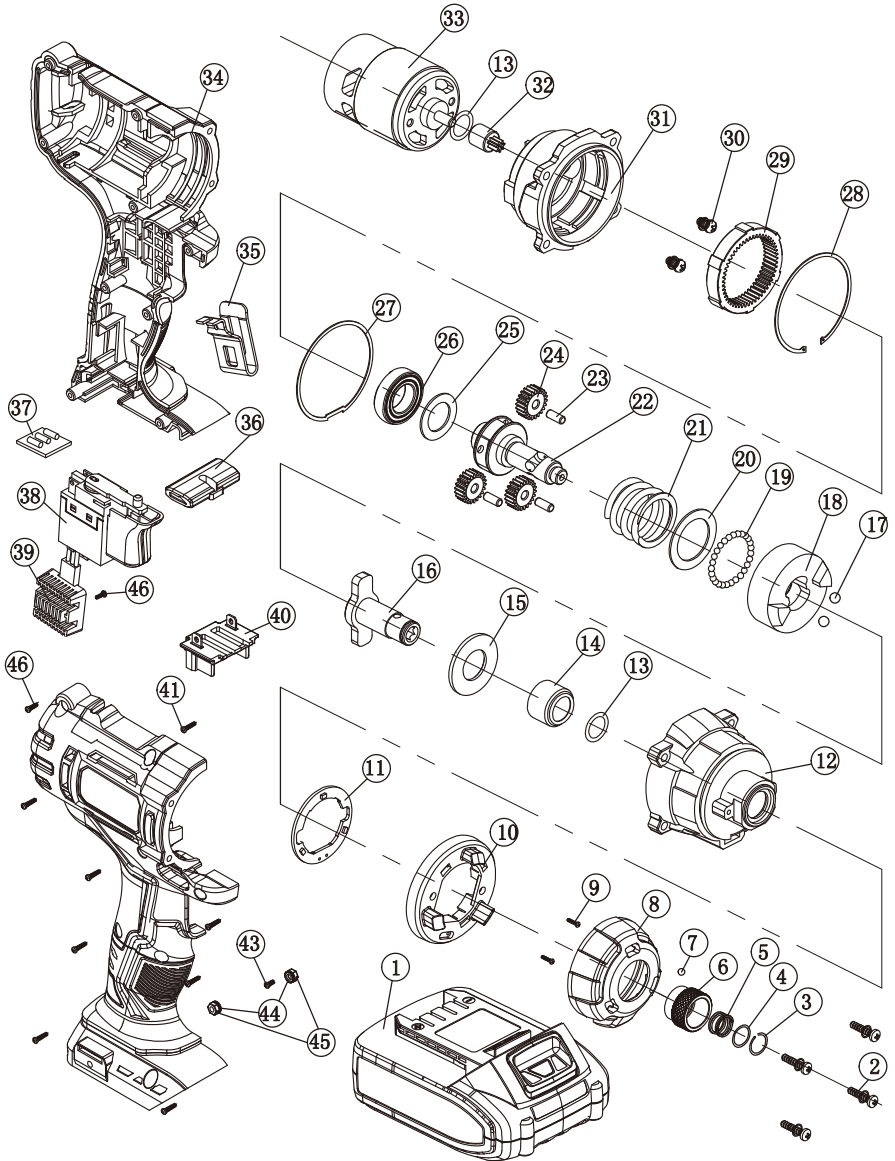

PARTS LIST

Always order by part number.

KEY #	PART #	PART NAME / QUANTITY	KEY #	PART #	PART NAME / QUANTITY
1	1290090019	Battery pack/1	25	2030020229	Washer (5) / 1
2	4030010263	ST3.9X25 / 1	26	4010010062	Bearing (6902z) / 1
3	2050080131	Outer circlip / 1	27	3190090011	Oil Proof Washer / 1
4	2030020001	Washer / 1	28	4100010013	Internal Circlip / 1
5	2050060004	Assembly sleeve spring / 1	29	2010090070	Inner Ring / 1
6	2040170007	Assembly sleeve / 1	30	4020010043	M4X8 / 2
7	4080030001	Ball ϕ 3.5 / 1	31	2020010027	Gear Box / 1
8	3140100022	Rubber sleeve / 1	32	2010180026	Motor Gear / 1
9	4020020028	M3X8 / 2	33	1039080004	Motor / 1
10	3150160282	Circuit Board Setting Ring / 1	34	3010020043	Enclosure / 1
11	1130040080	Aluminum Shell / 1	35	2030100069	Hook / 1
12	2020050098	Led Circuit Board / 1	36	3120030144	Direction Setting Button / 1
13	3140020001	O Type Ring / 1	37	1130030085	LED Circuit Board / 1
14	2010080002	Shaft Coat / 1	38	1060050017	Switch / 1
15	2030020002	Washer / 1	39	2020180005	Cooling Block / 1
16	2040050141	Outer Shaft / 1	40	3150170016	Electrode Plate / 1
17	4080070001	Ball 5.5 / 2	41	4030010145	ST2.9X16 Bald / 1
18	2040200011	Impact Block / 1	42	4030010039	ST2.9X20 Bald / 1
19	4080040001	Ball 4 / 21	43	4020010168	M3 X 12 / 1
20	2030020003	Washer 3 / 1	44	4040080003	Serrated Ring / 2
21	2050060181	Torque Spring / 1	45	4060010003	M3 Hexagon Nut / 2
22	2040050106	Inner Shaft / 1	46		
23	2040050106	Pin 4x9.8 / 3	47		
24	2010010064	Planetary Gear / 3	48		

⚠ WARNING: When servicing, use only original equipment replacement parts. The use of any other parts may create a safety hazard or cause damage to the tool.

Any attempt to repair or replace electrical parts on this tool may create a safety hazard unless repairs are performed by a qualified technician. For more information, call the Toll-free Helpline, at 1-866-349-8665.

WARRANTY

If this Benchmark tool fails due to a defect in material or workmanship within five years from the date of purchase, return it to any Home Hardware store with the original bill of sale for exchange. 3-year warranty for the battery and charger. This warranty does not include expendable parts including but not limited to blades, brushes, belts, light bulbs.

This warranty covers defects in material or workmanship only. It does not cover normal wear and tear, failure due to abuse/misuse, or defects caused by careless or accidental mishandling. If this Benchmark product is used for commercial or rental purposes, this warranty does not apply.

20V MAX IMPACT DRIVER



5 Year Limited Warranty
3 Year Limited Warranty on
Battery and Charger

BENCHMARKTM_{MC}

BENCHMARK TOOLS CANADA
ST. JACOBS, ONTARIO N0B 2N0
© 2020 Home Hardware Stores Limited

CUSTOMER SERVICE/TECH SUPPORT
1-866-349-8665

1239-103

Made in China



* This BenchmarkTM product carries a five (5) year LIMITED warranty against defects in workmanship and materials. The charger and batteries carry a three (3) year LIMITED warranty. See Owner's Manual for full details.



JD509920

**READ ALL INSTRUCTIONS BEFORE FIRST USE.
KEEP THIS MANUAL FOR FUTURE REFERENCE.
KEEP AWAY FROM CHILDREN.**

Maximum initial battery voltage (measured without a load)
is 20 volts. Nominal voltage is 18 volts.



**WEAR CSA APPROVED
EYE PROTECTION**



**WEAR EAR
PROTECTION**



**WEAR A
FACE MASK**