

QUICK REFERENCE GUIDE

Please register your product at
kingconnect.com/support.



DTP4900 & DTP4950

Designed and manufactured by

KING

Thank you for choosing the DISH Tailgater Pro!

NEW AND UNACTIVATED RECEIVERS

First-time use of your DISH® Tailgater® Pro should be at your residence or a location where you have good phone reception, as you will need to call a DISH mobile antenna specialist at 1-800-963-DISH (3474) to activate your receiver and begin viewing your satellite programming (do this at the end of step 5).

 The DISH Tailgater Pro is compatible with the following DISH receivers: **Wally® • ViP®211z • ViP211k • ViP211 • 411**

1  Do not apply rubber feet if you will be roof-mounting the antenna unit.

Lay the DISH Tailgater Pro on a soft, non-scratching surface and apply the (3) rubber feet.

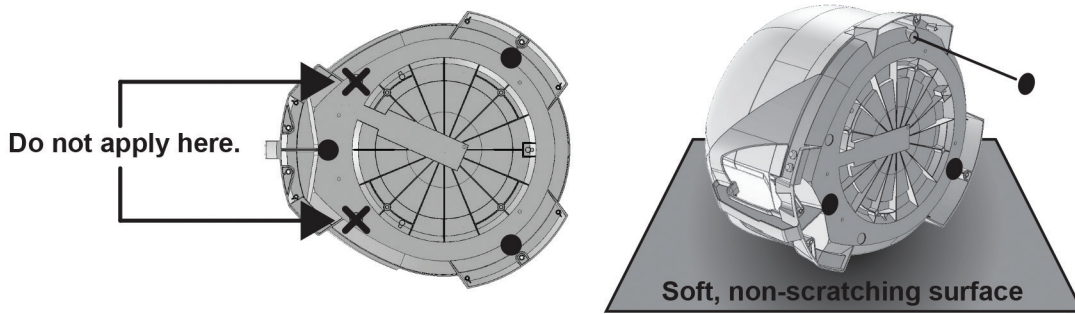

2 Place the DISH Tailgater Pro in a location with an unobstructed view of the southern sky.

Point handle north to speed up scan time.

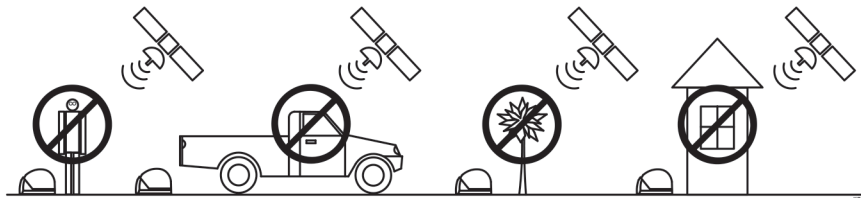

Obstructions such as people, vehicles, trees, buildings or any tall objects can block signal.

! If you move the DISH Tailgater Pro during or after the scan process, you will have to perform a new scan to reacquire signal.

3 Make connections in the following order: A, B and C.

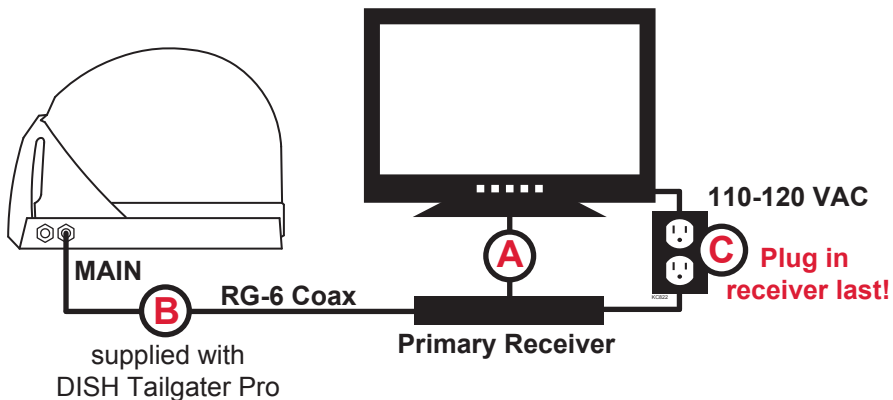

Do not over-tighten coax connections!

i When you plug in the receiver (make sure outlet is powered), the green power light on the front of the receiver should illuminate or begin cycling on and off. Wait for the green light to turn solid. This may take up to two minutes. If it does not turn solid, power on your receiver using the front panel POWER button.*

Front of Wally receiver



*On ViP211z models, this is located behind the door panel.

4 Turn on your TV.

The Mobile Antenna Setup screen should appear. (Make sure your TV is on the correct input that your DISH Tailgater Pro is connected to. Check input by pressing Source/Input button located on the side, back or front of your TV, or on your TV's remote.)

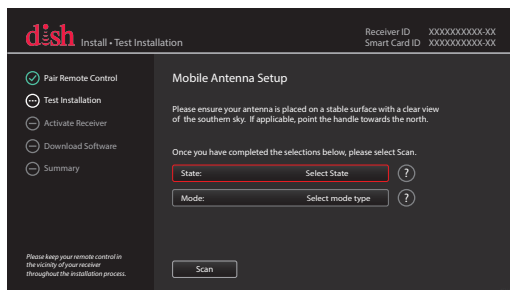

Wally receiver screen shown. Screen graphics will vary.



First time use: You may get other screens prompting you to do things before the Mobile Antenna Setup screen appears (such as instructions on pairing your remote to the receiver.)

On subsequent use, if the Mobile Antenna Setup screen does not appear:

***Wally receivers:** Unplug the Wally for 10 seconds, and then plug back in. (It may take several minutes for screen to appear.)*

***ViP receivers:** Press MENU, 6, 1, 1. When Point Dish screen appears, highlight "Check Switch" and press Select.*

5 Follow the on-screen instructions to perform a scan.



Mode selection for Wally receivers only: Choose the 110, 119, 129 trio unless in the northeastern United States; then choose the 61.5, 110, 119 trio.

When scan is complete:



NEW UNACTIVATED RECEIVERS: The on-screen instructions will guide you through an initial setup and activation procedure (see the operation section for new unactivated receivers in your Owner's Manual-see below). Upon completion, you will need to call a DISH mobile antenna specialist at **1-800-963-DISH (3474)** to activate your receiver.

ACTIVATED RECEIVERS: Watch TV. Enjoy!

Owner's Manual: For more information on mode selection, operation, troubleshooting, roof installation, the warranty, and accessories for your DISH Tailgater Pro, refer to the included Owner's Manual (Wally receiver version). If you have a ViP model receiver, you can access the DISH Tailgater with ViP Receiver Owner's Manual by going to kingconnect.com/support. Click on "Owners Manuals" and choose the manual for DISH Tailgater with ViP receiver.