

# WINEGARD®

## RoadTrip® Minimax Stationary Automatic Satellite TV Antenna Model RTS-80W

Made in the U.S.A.

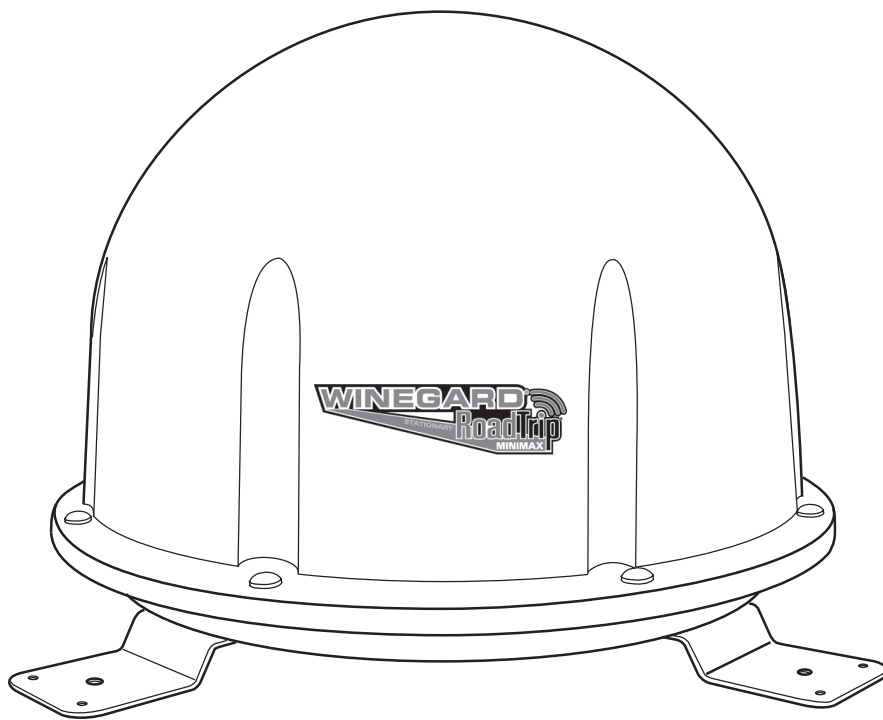

### PRODUCT REGISTRATION

Please register your Winegard product by filling out and returning the Product Registration card provided or by completing the online registration form at <http://www.winegard.com/registration>

Serial No.

# **Parts Included • Tools Needed • Unpacking the Unit**

---

## **PARTS INCLUDED:**

1 Dome  
1 base with electronics, dish, dual LNBF

## **TOOLS NEEDED FOR UNPACKING & INSTALLATION:**

Level	3/8" Open end wrench
Drill with 3/4" bit	7/16" Open end wrench
1-1/4" hole saw (if mounting switch in wall)	Sealant (consult RV manufacturer for proper type for your roof material)
Phillips screw driver #2	

## **UNPACKING THE UNIT:**

1. Open box and remove packing material.
2. Lift unit out of box vertically. Do not turn box and "roll" out, or turn upside down to remove.



**If using knife to open carton, BE CAREFUL. Do not cut the dome on the unit.**



**USE 2 PEOPLE when removing the unit from the carton.**



**DO NOT PAINT DOME! Painting dome will cause signal degradation and will void your warranty.**

## **For Winegard Warranty Information:**

Attn: Technical Services  
Winegard Company  
3111 Kirkwood St.  
Burlington, IA 52601  
800-788-4417  
Fax: 319-758-5854

## **Disclaimer:**

Although every effort has been made to insure the information in this manual is correct and complete, no company shall be held liable for any errors or omissions in this manual. Changes and technological advances are continuously being made in the satellite market. Information provided in this manual was accurate at the time of printing. If the RoadTrip Minimax does not function as expected, please contact Winegard Company at (800) 788-4417 or visit our website at [www.winegard.com](http://www.winegard.com).

## **Trademarks:**

Winegard and RoadTrip Minimax are registered trademarks of Winegard Company. DISH Network is a registered trademark of EchoStar Communications Corp. DIRECTV is a registered trademark of Hughes Electronics Corp. All trademarks contained in this manual are property of their respective owners. Reference made to products or services provided by companies, other than Winegard Company, does not represent any endorsement of those products or services.

# Quick Reference Guide

**This model is PRESET for DIRECTV receivers.**  
**If you have a DISH Network or BELL TV receiver, you must change the numbered switches (see figures below).**

**FACTORY PRESET  
DIRECTV SWITCH SETTINGS**

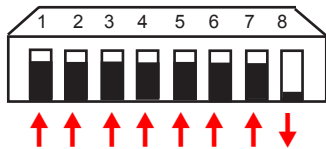

**BELL TV**

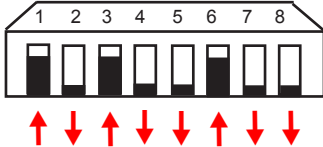

**TO CHANGE SWITCH SETTINGS FOR DISH NETWORK. SIMPLY MOVE #4 & #7 TO DOWN POSITION (#8 SHOULD REMAIN DOWN ALSO).**

**DISH NETWORK**

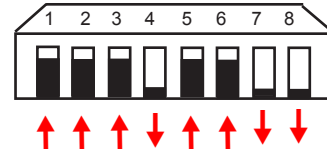

**DISH NETWORK HYBRID**

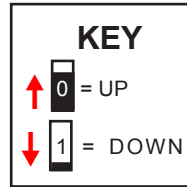
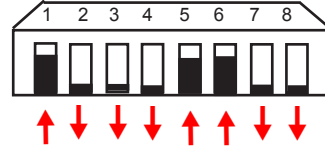

**Installing unit on roof of vehicle —**



**Install in DRY conditions only!**

**IMPORTANT!** Do not install this system in the rain, or under any wet conditions. Moisture may affect electronics and void your warranty!

1. For best performance and to reduce signal acquisition time, park vehicle on a level surface; level the RV.

2. Select a level spot on your roof for installation.

**WARNING:** Level the base front to back and side to side. If base is not level the antenna may require more time to locate the correct satellite or may not locate the correct satellite.

3. Ensure proper distance to other rooftop equipment is maintained.

Be sure no roof-mounted equipment is blocking the satellite "line of sight"; see chart below.

Using this chart, determine the minimum distances to other equipment.

Obstruction Ht.	Unit Clearance
8"	15"
10"	20"
12"	25"
15"	35"

Hybrid Mode settings are for use in areas where the standard DISH Network settings fail to provide HD programming.

**FIGURE 1**

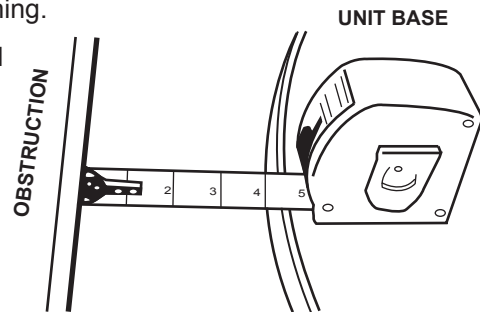

4. After selecting location for unit (see Step 2), place the unit on the centerline of the vehicle.

5. Position base so that cables exit toward the rear of vehicle.

**FIGURE 2**

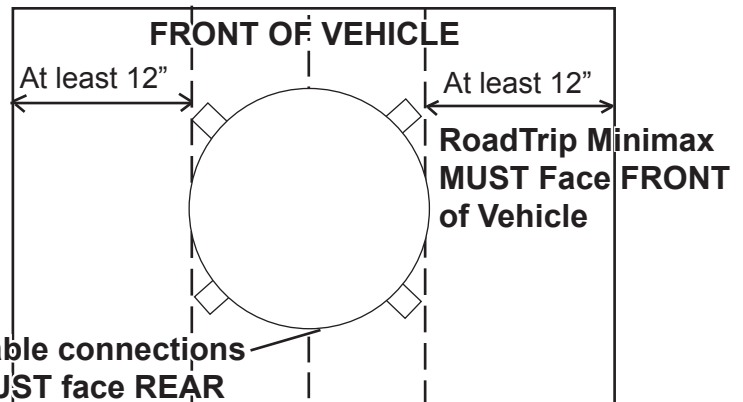

The distance from the edge of the roof to the rear corner of any foot should be at least 12" on both sides of the dish to ensure proper installation.

6. Place the unit on the roof in its permanent location and mark around each base foot, Figure 3.

**FIGURE 3**

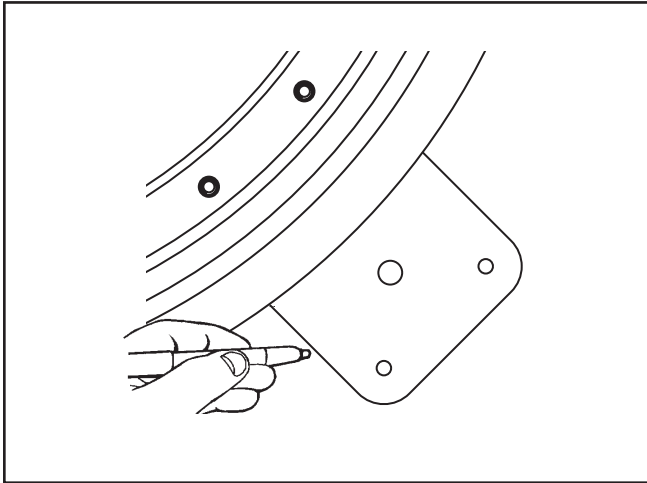

7. Clean roof area where the base feet will be attached to the roof. Do not erase your marks!

8. Put approved sealant in the areas marked for the base feet. Place base feet on top of the sealant and screw down with the (3) #10 screws for each foot.

9. After all base feet are secured to roof, put sealant around edge of feet and over screws.

**Cable entry installation —**

1. Connect the quick disconnect power cable to the panel mount on the back of the RoadTrip Minimax unit. See Figures 4 & 5 below.

**FIGURE 4 QUICK DISCONNECT SOCKET LOCK (ON TOP OF THE CONNECTOR)**

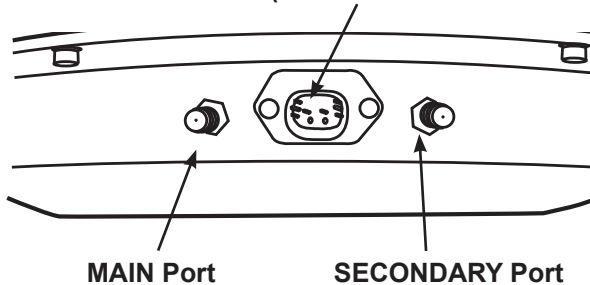

**FIGURE 5 LOCK POWER PLUG**

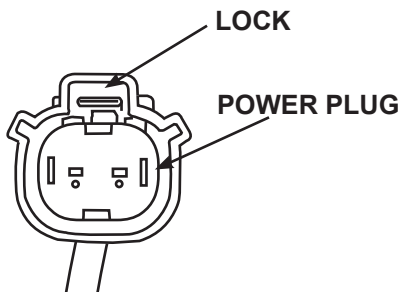

Decide the best location for the power and coax cables to enter the vehicle, and the location of the power switch and receiver. Drill a 1/2" hole in the roof, push wires inside.

2. Connect the Primary receiver to the Primary Port on the panel mount.
3. For a two receiver installation, connect a second coax cable (not provided) to the SECONDARY connector on base and run cable along roof to second receiver location.
4. Place cable-entry plate over hole and cables. Screw in place. Seal plate and screw holes with approved sealant (not included).
5. Depending on the length of the cable on the roof, you may need to use cable clamps or wire ties (not provided) between the unit and your cable-entry plate. Clamping the cable every 12"-16" should eliminate any unnecessary cable movement, Figure 6.



**NICKS OR CUTS IN WIRING JACKET MAY CAUSE WATER TO LEAK INTO VEHICLE.**

**FIGURE 6**

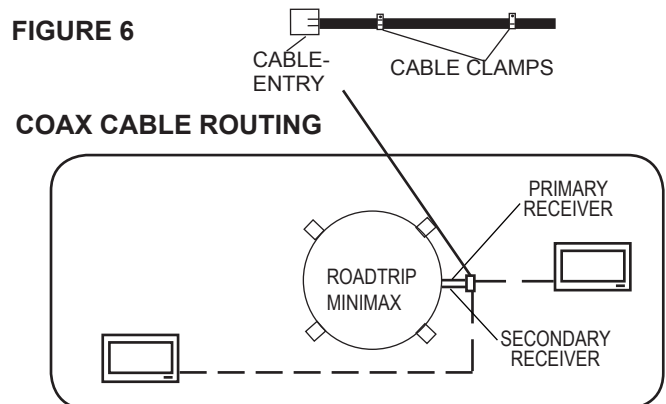

## INSTALLING THE POWER SWITCH

1. Choose a location to install the RoadTrip Minimax power ON/OFF switch. Remember when selecting a location, you will need to run the +12VDC power cable from the RoadTrip Minimax antenna to the switch. Be sure the switch is in the OFF position before continuing. See Figure 7 below.

Wall or panel mount: Drill 1-1/4" hole, pull wires through wall or panel.

2. Connect the ground wire from the vehicle and the BLACK ground wire from the antenna together, using large yellow flag connector.

3. Connect the YELLOW flag connector to the silver spade on the switch.

4. Connect the RED wire from the antenna to the small RED flag connector.

5. Connect small RED flag connector to center spade on switch.

6. Connect the +12 V power wire from the vehicle to a small RED flag connector.

7. Connect small RED flag connect to isolated spade on switch.

**FIGURE 7**

**ON/OFF ROCKER SWITCH WITH LIGHT**  
(Shown in OFF position.)

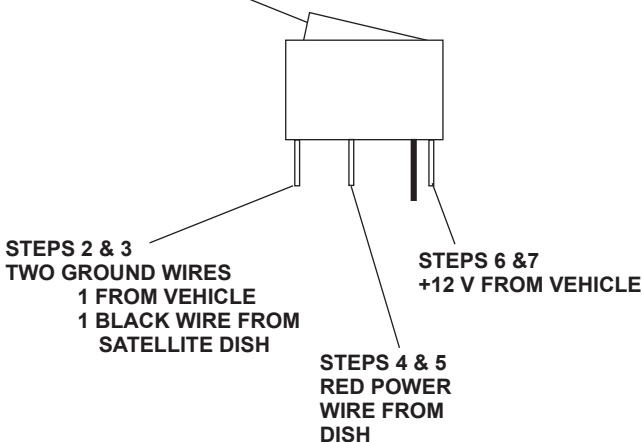

## CONNECTING RECEIVERS

### Connecting ONE receiver

1. Connect the coax cable from the antenna to the "SATELLITE IN" on the receiver.
2. See page 6 for receiver set-up.

### Connecting TWO receivers

1. Connect the coax cable coming from the antenna to the "SATELLITE IN" input on the primary receiver. The primary receiver is the receiver used most often and will toggle between satellites.
2. Connect the secondary coax cable coming from the antenna to the "SATELLITE IN" input on the secondary receiver.

**NOTE: Secondary receiver will not toggle.**

3. See page 6 for receiver set-up.

**Note:** During the RoadTrip Minimax antenna's normal search process, you may hear a slight grinding sound as the unit checks its limits. This is normal and does not harm the unit.

## Operating the RoadTrip® Minimax

1. Turn on receiver and television set. The RoadTrip Minimax antenna must be connected to a receiver that is plugged into 120 VAC.

2. Verify that you are getting the receiver's menu screens on the television. These screens are available with or without the dish finding the signal.

3. Turn the power switch on for the RoadTrip Minimax antenna. The dish will detect if it is already on a satellite signal. If it detects a signal, the dish will move to check it's alternate satellite and then move back to the original satellite signal that is on.

4. If no signal was detected, the dish will begin its search to locate the primary satellite. Once the dish locates a signal, it will pause long enough to identify which satellite it has located. This may or may not be visible on your receiver's point dish screen.

5. After the unit has verified that it has the correct satellite, it will move to check the alternate satellite and move back to the primary satellite to complete the search routine.

6. If you do not have signal, see *Troubleshooting*, p.9.

**NOTE: Because the RoadTrip Minimax antenna uses information from the last location that it was on a signal, satellite acquisition may take longer if the dish is inactive over long distance traveling.**

**DIRECTV must be set to the "two" satellite, oval dish setting. Refer to your receiver manual.**

**DISH Network receivers must have the check switch set to "SW64". See page 6.**



Use your on-screen guide to locate your channel rather than "channel surfing". This will result in smoother operation.

## Basic RoadTrip Minimax Antenna Wiring

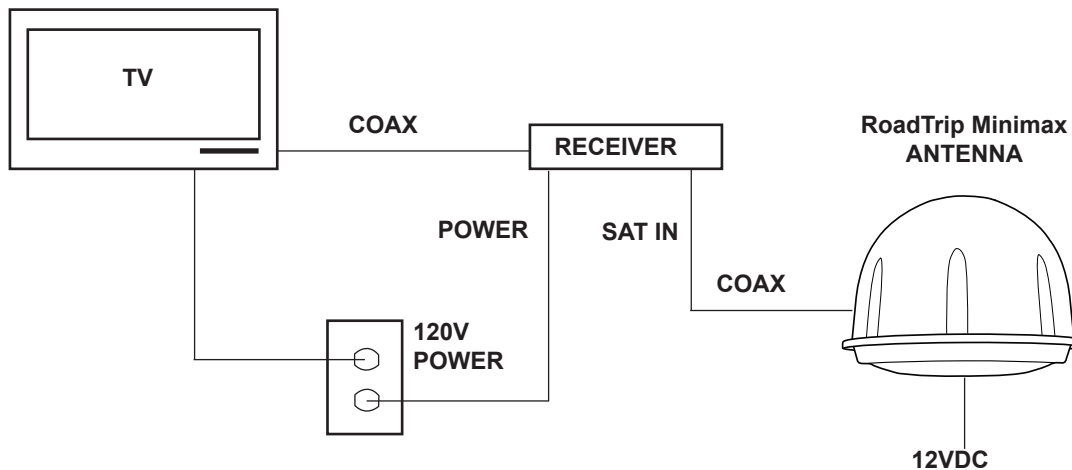

### To toggle between satellites when subscribing to multi-satellite programming—

The RoadTrip® Minimax antenna will toggle between the primary or alternate satellites for either DISH Network or DIRECTV. Both have programming on more than one satellite. When a channel is selected on the remote control and is not on the satellite currently selected, the unit will automatically toggle to the correct satellite.

#### DIRECTV® programming

1. DIRECTV receivers must be set for oval dish 2 sat selection to enable toggling between primary 101°W satellite and alternate 119°W satellite only. (Consult receiver manual for procedure.) After receiver is set for the correct dish selection, when you request a channel located on a different satellite, the unit will automatically toggle to that satellite.

**DIRECTV must be set to the “two” satellite, oval dish setting. In some cases, the two satellite option may not be available, when this happens, use the three satellite option. Refer to your receiver manual for more information.**

#### DISH Network® programming (DISH 500)

DISH Network receivers must have the “SW64” switch installed in order to toggle between the primary 119° satellite and the alternate 110° satellite. (Consult your receiver manual for the procedure to reach the “check switch” menu.)

**NOTE: This “SW64 Switch” is a DISH Network receiver setting, NOT a physical part.**

#### To install the “SW64” switch:

1. Before turning on your RoadTrip Minimax antenna, make sure that your satellite receiver and

television are turned on and your receiver is on the “point dish” menu. (Consult your owner’s manual to reach this menu.)

2. Turn on the RoadTrip Minimax system and wait for the unit to acquire a signal on satellite 119°.

3. You now have six minutes to complete Check Switch test. Consult your receiver manual for instructions on running the test. Be sure that Superdish and Alternate are unchecked if applicable. Onscreen options may vary by receiver.

4. During the Check Switch Test, the receiver will begin checking the switch by toggling between satellites. When this is completed, SW64 will appear on the screen. It will be at the top of the screen, satellite designations will be below, showing odd and even transponders. See illustration below.

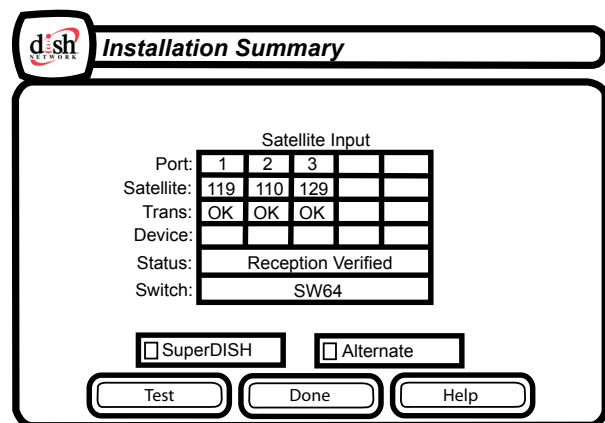

Check Switch screen display

**NOTE: Be sure the “Superdish” and “Alternate” boxes are NOT checked.**

If a switch other than SW64 appears, or you have an X in one of the boxes below the satellites, repeat Check Switch Steps.

5. Your system is now set up to toggle between satellites. It will automatically move to the correct satellite when a channel is selected with your remote control.

**NOTE:** Once these steps are completed, you won't have to perform this test again, unless Check Switch was performed on another satellite dish, such as a home dish.



**Toggle:** Your Winegard automatic satellite dish will move from the primary to the alternate satellites in order to receive multi-satellite programming.

**Note:** The RoadTrip Minimax antenna is designed to be maintenance free. However, it is a good idea to clean the dome from time to time with a soft cloth, water and dish soap.

**Warning:** Painting the RoadTrip Minimax dome voids the warranty, degrades signal strength and may cause damage to the antenna.

## Troubleshooting

### PROBLEM

### SOLUTION

<p>The RoadTrip Minimax antenna does not attempt to find a satellite or it never moves.</p>	<ol style="list-style-type: none"><li>1. Check +12 V wires at unit to verify the quick disconnect is locked into the socket.</li><li>2. Make sure the RoadTrip Minimax antenna is plugged in.</li></ol>
<p>The dish never stops on any of the signals that it sees.</p>	<ol style="list-style-type: none"><li>1. Make sure that your receiver is set up correctly. For DISH NETWORK, the check switch should read either “<b>Unknown</b>” or “<b>SW64</b>”. For DIRECTV, the receiver should be set for a <b>Two Satellite Oval Dish</b>. <b>In some cases, the ‘Two satellite’ option may not be available. In these cases, select Three satellite oval.</b></li><li>2. Make sure the Main coax cable from antenna is run to “satellite in” on back of your receiver and all coax connections are made properly.</li></ol>
<p>With DIRECTV, the dish will find the alternate satellite but it never finds the primary satellite.</p>	<p>Make sure that the Switches on the Electronics Control Box are set for DIRECTV. See page 3. These switches are found under the dome, inside the Electronics Control Box.</p>
<p>I am not getting all the DISH Network channels I subscribed to.</p>	<p>Go to the check switch menu in receiver. Make sure that it's set for SW64 and lists both even and odd transponders on satellites 110°, 119° and 129°.</p>
<p>The RoadTrip Minimax antenna never sees any signals, it just keeps searching.</p>	<ol style="list-style-type: none"><li>1. Rain, snow or excessive dew on the dome can interrupt the signal. Snow and dew can be brushed off the dome. If heavy rain or snowfall is blocking the signal, it may be necessary to wait until the weather clears.</li><li>2. Check to see if the southern sky is clear. Trees, buildings, large signs or an overpass can block the signal. Find an area where you can be sure that this is not the problem and try again.</li><li>3. Run a single, good coax cable directly from the RoadTrip Minimax to the satellite receiver by-passing everything.</li><li>4. Make sure the receiver has power and the satellite dish is connected to the “Sat In” jack.</li></ol>
<p>I have switched satellite service providers. How do I set my dish for my new provider?</p>	<p>You will need to remove the dome, and set switches to correct provider. See page 3.</p>
<p>My receiver appears to be locked up. I cannot get any response from it.</p>	<ol style="list-style-type: none"><li>1. Power off receiver and turn back on.</li><li>2. Hold in power button on receiver for three seconds and release.</li><li>3. Unplug receiver from outlet for 20 seconds and plug back in.</li></ol>
<p>With DISH Network, my RoadTrip Minimax antenna appears to lock onto signal, but my receiver does not show a picture or a signal reading.</p>	<p>Check the “Check Switch” installed in your receiver. If anything other than “Unknown” or “SW64” is installed, please run the “Check Switch” test. See page 6 for help running this check.</p>
<p>The DIRECTV receiver shows a signal but the Road-Trip Minimax antenna never stops searching.</p>	<p>Exit the receiver menu screens and try running the search from the program guide screen.</p>



## **Appendix A Satellite Coverage Maps and Receiver Compatibility**

### **A.1 DISH NETWORK PROGRAMMING**

The RoadTrip Minimax antenna will operate with most DISH Network receivers.

**Winegard does not recommend using receivers with hard drives not recommended by the manufacturer for mobile applications. Winegard recommends using a standard DISH Network receiver.**

The antenna will locate and toggle between satellites 129°, 119° and 110°.

The RoadTrip Minimax antenna will not operate in areas where satellite 129°, 119° and 110° are not available.

Refer to figure below for an operational coverage map for satellite 119° and 110°. Satellite coverage maps are based on level, stationary operation.

**Reception interruption may also occur during adverse weather conditions.**

DISH Network satellites 119° and 110° coverage area (Dotted area indicates coverage).\*

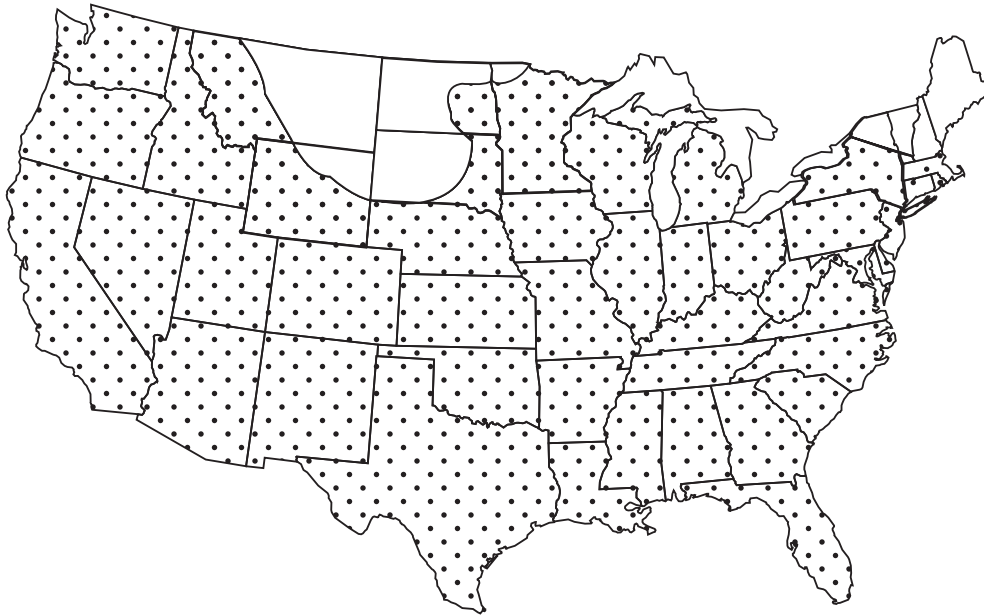

\*Coverage maps are for reference only and do not guarantee coverage.

**Note:** There are certain areas within the U.S. where the RoadTrip Minimax antenna may experience limited or no coverage of the 129° satellite for HD programming. DISH Network home coverage has the same limitations. Problem areas include: Washington, Oregon and California (limited coverage may extend past these areas). Contact DISH Network for any additional coverage questions (888.825.2557).

**Hybrid Mode is for use with DISH Network while in the Northeast where the 129° satellite is not available. The Map below shows the coverage area for the 129° satellite.**

DISH Network satellite 129° coverage area (Dotted area indicates coverage).\*

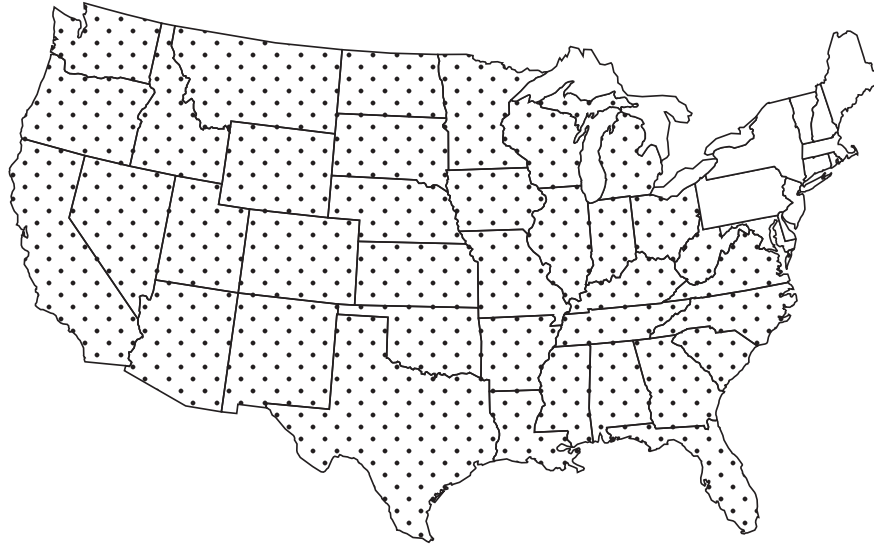

\*Coverage maps are for reference only and do not guarantee coverage.

DISH Network satellite 61.5° coverage area (Dotted area indicates coverage).\*

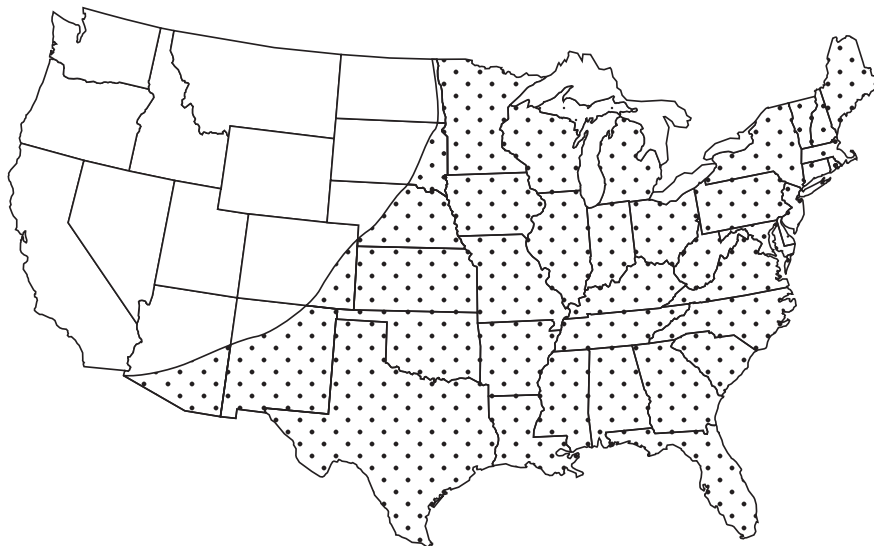

\*Coverage maps are for reference only and do not guarantee coverage.

**DISH NETWORK® EASTERN ARC**

If neither DISH Network Standard Mode or DISH Network Hybrid Mode will provide an HD signal, consult the maps above. If you are in the 61.5° coverage area, use DISH Network Eastern Arc.

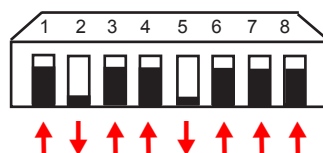

**DISH NETWORK 72° SATELLITE USES THE ODD TRANSPONDERS ONLY. A CHECK SWITCH WILL FAIL TO SEE ANY EVEN TRANSPONDERS. THIS IS NORMAL.**

## A.2 DIRECTV PROGRAMMING

The RoadTrip Minimax antenna will operate with most DIRECTV receivers. The antenna will locate and continually track satellites 101° and 119°.

**Winegard does not recommend using receivers with hard drives not recommended by the manufacturer for mobile applications. Winegard recommends using a standard DIRECTV receiver.**

RoadTrip Minimax antenna will not operate in all areas where satellites 101° and 119° are available. Refer to the figures below for an operational coverage map of satellite 101° and 119°. Satellite coverage maps are based on level, stationary operation.

**Reception interruption may also occur during adverse weather conditions.**

DIRECTV satellite 101° RoadTrip Minimax coverage map (Dotted area indicates coverage).\*



DIRECTV satellite 119° RoadTrip Minimax coverage map (Dotted area indicates coverage).\*

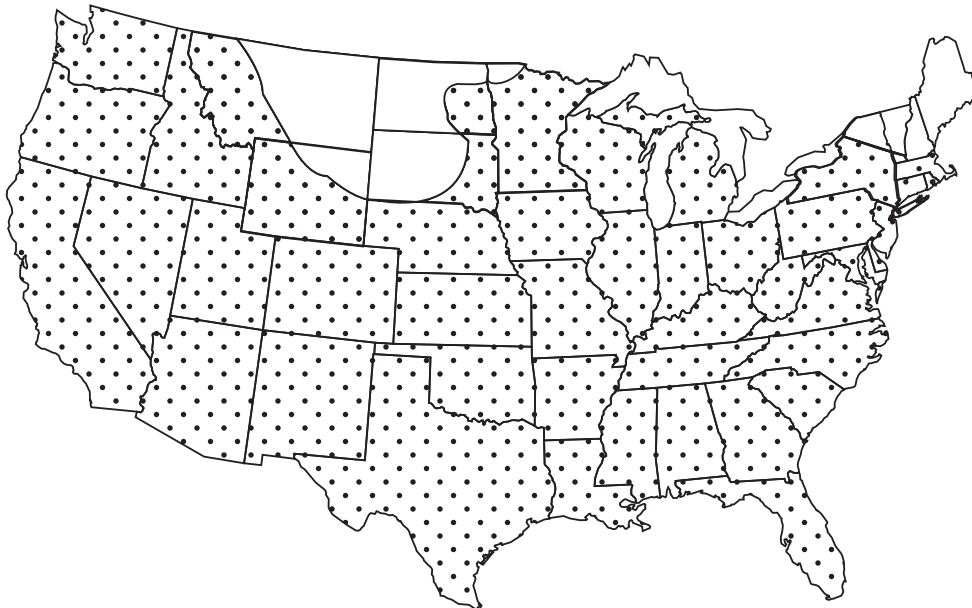

\*Coverage maps are for reference only and do not guarantee coverage.

# Specifications & Warranty

## Features and specifications

- One button operation
- Supports up to 2 single or 1 dual receiver.
- Depending on receiver type and location, you can access satellites
  - DISH Network 129°, 119°, 110° or 61.5°
  - DIRECTV 119° or 101°
  - BELL TV 91° or 82°
- Depending on programming, can access DISH NETWORK's East Coast local feeds.
- Powder coated aluminum base.
- Elevation range 20° to 92°; azimuth +360° (0-692°).
- UV protected plastic dome.
- Compact size —
  - 20" diameter, 15.6" height
  - Shipping size - 25" x 22 3/4" x 16 1/2"
  - Unit weight - 13.5 lbs.
  - Shipping weight - 23 lbs.
- Operating temperature -13°F to +140°F
- Specifications for max amperage 5.0A
- Specifications for unit operating voltage. -10.5 - 13.8V
- Specifications for supply voltage. 12 - 13.8V

### WINEGARD MOBILE PRODUCTS LIMITED WARRANTY (2 YEARS PARTS; 1 YEAR LABOR)

Winegard Company warrants this product against defects in materials or workmanship for a period of two (2) years from the date of original purchase. During year one (1) of such warranty, Winegard Company will also pay authorized labor costs to an authorized Winegard dealer to repair or replace defective products. No warranty claim will be honored unless at the time the claim is made, Customer presents proof of purchase to an authorized Winegard dealer (to locate the nearest authorized Winegard dealer, contact Winegard Company, 3000 Kirkwood Street, Burlington, Iowa 52601, Telephone 800-288-8094 or visit [www.winegard.com](http://www.winegard.com)). Customer must provide proof of purchase with a dated sales receipt for the Winegard product to verify the product is under warranty. If the date of purchase cannot be verified, the warranty period shall be considered to begin thirty (30) days after the date of manufacture.

If a defect in material or workmanship is discovered, Customer may take the product to an authorized Winegard dealer for service. Customer must provide proof of purchase to verify the product is under warranty. If the product is brought to an authorized Winegard dealer for service prior to expiration of year one (1) of the warranty period and a defect in material or workmanship is verified by Winegard Technical Services, Winegard Company will cover the Winegard dealer's labor charges for warranty service. The Winegard dealer must contact Winegard Technical Services in advance for pre-approval of the service. Approval of the service is at the sole discretion of Winegard Company.

Alternatively, Customer may ship the product prepaid to Winegard Technical Services (located at 3111 Kirkwood Street, Burlington, Iowa 52601, Telephone 800-788-4417). Customer must return the product along with a brief description of the problem and provide Winegard Technical Services with Customer's name, address, and phone number. Customer must also provide proof of purchase to verify the product is under warranty. If the product is returned before the expiration of the warranty period, Winegard Company will (at its option) either repair or replace the product.

This Limited Warranty does not apply if the product has been damaged, deteriorates, malfunctions or fails from: improper installation, misuse, abuse, neglect, accident, tampering, modification of the product as originally manufactured by Winegard in any manner whatsoever, removing or defacing any serial number, usage not in accordance with product instructions or acts of nature such as damage caused by wind, lightning, ice or corrosive environments such as salt spray and acid rain.

#### RETURN AUTHORIZATION POLICY

A Return Material Authorization (RMA) is required prior to returning any product to Winegard Company or Winegard Warranty Services under this warranty policy. Please call our Technical Services Department at 800-788-4417 or send an e-mail to [warranty@winegard.com](mailto:warranty@winegard.com) to obtain the RMA number. Please furnish the date of purchase when requesting an RMA number. Enclose the product in a prepaid package and write the RMA number in large, clear letters on the outside of the package. To avoid confusion or misunderstanding, a shipment(s) without an RMA number(s) or an unauthorized return(s) will be refused and returned to Customer freight collect.

WINEGARD COMPANY DOES NOT ASSUME ANY LIABILITIES FOR ANY OTHER WARRANTIES, EXPRESS OR IMPLIED, MADE BY ANY OTHER PERSON. ALL OTHER WARRANTIES WHETHER EXPRESS, IMPLIED OR STATUTORY INCLUDING WARRANTIES OF FITNESS FOR A PARTICULAR PURPOSE AND MERCHANTABILITY ARE LIMITED TO THE TWO YEAR PERIOD OF THIS WARRANTY.

In states that do not allow limitations on implied warranties, or the exclusion of limitation of incidental or consequential damages, the above limitations or exclusions do not apply.

Some states do not allow limitations on how long an implied warranty lasts, or the exclusion of limitation of incidental or consequential damages, so the above limitations or exclusions may not apply to you.

This warranty gives Customer specific legal rights. Customer may also have other rights that may vary from state to state.

SATELLITE RECEIVER WARRANTY:  
See manufacturer's limited warranty policy.

Rev. 2/08

