

2500 LB ELECTRIC A-FRAME JACK

OWNER'S MANUAL



SPECIFICATIONS:

- Models Applicable: 2500 lb Electric A-Frame Jack
- Maximum Lift Capacity: 2500 lbs (continuous use)
- Retracted Height: 31 3/8"
- Vertical Travel: 18"
- Power Requirements: 12V DC
- Outer Tube Diameter: 2"
- Power Cord Length: 6ft, #10 Gauge Wire
- Foot Pad Diameter: 5 1/2"
- LED Work Lights For Easy Nighttime Hookups
- Shipping Weight: 23 lbs

CONTENTS OF KIT:

- Removable Foot Pad
- 3/8" Safety Lock Pin
- Manual Crank Handle
- 30A Fuse kit
- Three 3/8" Star Washers
- 3 Bolts
- Wire butt connectors
- Terminal ring

TOOLS REQUIRED:

- 9/16" Wrench
- Torque Wrench
- Wire Cutters / Crimpers

NOTICE:

IF PRODUCT COMPONENTS ARE MISSING OR DAMAGED, DO NOT RETURN TO DEALER. CONTACT THE MANUFACTURER.



WARNING: Read carefully and understand all instructions before operating. Failure to follow the safety rules and other basic safety precautions may result in serious personal injury.

INTENDED USE

A trailer jack makes coupling and uncoupling from the hitch ball easier.

GENERAL SAFETY RULES



WARNING: Read and understand all instructions. Failure to follow all instructions listed below may result in electric shock, fire and/or serious injury.



WARNING: The warnings, cautions, and instructions discussed in this instruction manual cannot cover all possible conditions or situations that could occur. It must be understood by the operator that common sense and caution are factors which cannot be built into this product, but must be supplied by the operator.

SAVE THESE INSTRUCTIONS

WORK AREA

- **Keep work area clean**, free of clutter and well lit. Cluttered and dark work areas can cause accidents.
- **Keep children and bystanders** away while using a trailer jack. Distractions can cause you to lose control, so visitors should remain at a safe distance from the work area.
- **Be aware of all power lines, electrical circuits**, water pipes and other mechanical hazards in your work area, particularly those hazards below the work surface hidden from the operator's view that may be unintentionally contacted and may cause personal harm or property damage.
- **Be alert of your surroundings.** Using a trailer jack in confined work areas may put you dangerously close to cutting tools and rotating parts.

PERSONAL SAFETY

- **Use personal protective equipment. Always wear eye protection.** Safety equipment such as dust mask, non-skid safety shoes, hard hat, or hearing protection used for appropriate conditions will reduce personal injuries.
- **Do not overreach. Keep proper footing and balance at all times.** This enables better control of the trailer jack in unexpected situations.
- **Dress properly. Do not wear loose clothing or jewelry. Keep your hair, clothing and gloves away from moving parts.** Loose clothes, jewelry or long hair can be caught in moving parts.

JACK USE AND CARE

- **Use on smooth, flat surfaces only.**
- **Do not force the trailer jack. Do not attempt to lift more than the 3000 lb maximum lifting capacity of this jack.**
- **Store idle jacks out of the reach of children and do not allow persons unfamiliar with the jack or these instructions to operate it.**

- **Maintain your trailer jack. Check for misalignment or binding of moving parts, breakage of parts and any other condition. If damaged, have the jack repaired before use.**
- **Use the jack and accessories in accordance with these instructions, taking into account the working conditions and the work to be performed.** Use of the trailer jack for operations different from those intended could result in a hazardous situation.

OPERATION



WARNING: Do not use blocks to increase ground clearance — the trailer can tip and fall. Replace jack if worn, damaged or not operating freely.

Installation Instructions

1. Block the tires of the trailer and support the trailer tongue.
2. The powered A-Frame Jack has been designed to attach to the top surface of the A-frame coupler.
3. Disconnect the battery ground wire.
4. Place the jack outer tube through the A-frame coupler hole. Remove the tape that masks one of the three mounting holes on the jack; this exposed bare metal is to ensure the best ground possible for the jacks' electrical system. Touch up bare metal with paint or grease it after installed to prevent rust. Insert the electric jack into the jack hole, aligning the bolt holes so the motor housing is facing forward
5. Attach the jack using three bolts provided. Lock/star washers are recommended to ensure a metal-to-metal contact between jack and coupler for proper grounding. Torque bolts to 15-20 ft-lbs. If bolts don't fit coupler holes' purchase grade 5, 3/8-16 UNC bolts with washers and nuts to attach.
6. Route the red power wire along the trailer to the battery. Install fuse holder to the power wire using butt connector and terminal ring (close to battery so its inside battery box), attach to positive terminal of battery. Alternatively, wire the jack directly to the reset breaker if available. The reset breaker maybe located at the corner of the first cross member of the A-frame.
7. This unit has a built-in circuit breaker which automatically trips and resets. Reconnect the battery ground cable.
8. Check for proper installation by activating the motor switch to ensure the jack travels in both directions. Jack is internally grounded; a ground wire is not necessary.

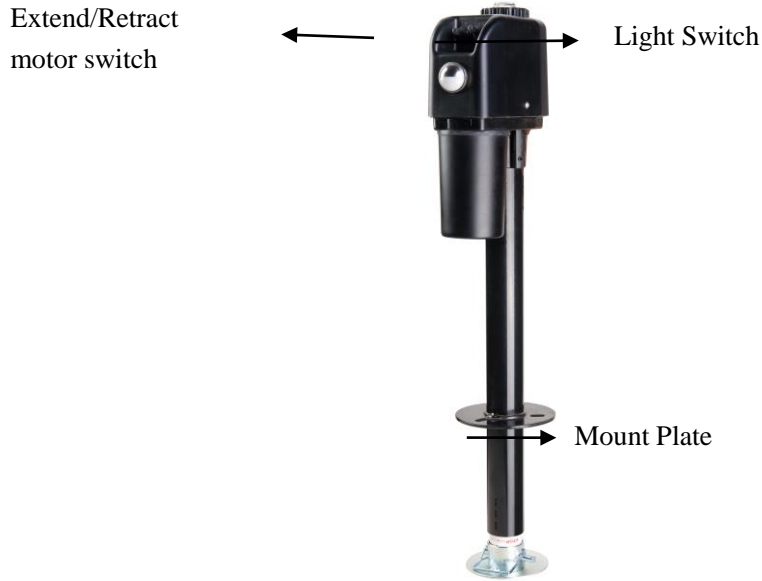

9.

Operation

1. Chock wheels of trailer.
2. To raise the trailer off the ball, open the coupler and toggle the motor switch to extend the jack.
3. To lower the trailer on to the ball, activate the motor switch in the opposite direction. This will retract the jack. After the coupler, has fully engaged the ball, continue retracting the jack up to the "STOP" decal on the inner tube. Be sure to close the coupler.
4. If for any reason electric power is lost, remove the round plastic cap located on the top surface of the jack, insert the manual crank (included) and rotate in desired travel direction.



CAUTION: If the trailer tongue is too heavy, do not attempt to lift it; seek assistance.

1. Turn handle clockwise to raise.
2. Turn handle counterclockwise to lower.



CAUTION: Do not tow trailer with jack in lowered position.

MAINTENANCE

- **Maintain your trailer jack.** Before each use, inspect the general condition of the jack. Check for loose hardware, misalignment or binding of moving parts, cracked or broken parts, damaged electrical wiring, and any other condition that may affect its safe operation.
- **Keep all moving parts lightly lubricated to prevent corrosion.**
- **After use,** wipe external surfaces of the tool with clean cloth.

DIAGRAM & PARTS LIST

REF	DESCRIPTION
A-F	Upper Jack Assembly; includes all housing, gear motor box assembly & items A-F
A1	Operating switch, (1) Extend/Retract (Item # 2500-03)
A2	Operating switch, (1) Light -on/off (Item # 2500-04)
B	Switch boot (2pack) (Item # 2500-05)
C	LED light (photo showing light on side is of 3500 jack. 2500 light in front under switches). (Item # 2500-06)
D	Circuit breaker
E	Cap with Bubble level (Item # 2500-3755E)
F	Motor (Item # 2500-18)
	Top Housing/Cover (Item #2500-02)
	Motor Housing/Cover (Item # 2500-20)
G-H	Lower Jack Assembly; includes outer jack tube, Inner jack tube, screw shaft & items G-H
G	Removable foot pad (Item # 2500-25)
H	3/8" safety lock pin (Item # 2500-26)
I	Manual crank handle (Item # 2500-24)
J	Star washer (3 pieces)
K	Power lead
M	Limited Gear Box
N	Wire butt connector
O	Terminal ring
P	30A spare fuse

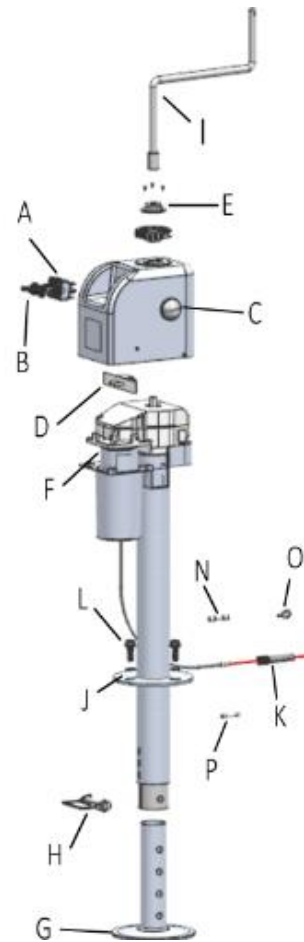

Customer Notes: