



INSTRUCTION MANUAL

Welcome

Congratulations on the purchase of your new *BrakeBuddy*.[®] The *BrakeBuddy* was designed and built as an auxiliary braking system to operate in conjunction with the existing braking system in your car or truck.

Use of the *BrakeBuddy* in a manner inconsistent with these instructions may result in serious personal injury or death and may cause serious property damage.

INSTALLATION INSTRUCTIONS

You must carefully read and understand these instructions prior to the use of this product.

1. Remove the *BrakeBuddy* and accessories from the shipping carton. (See parts list and diagram – Figure 1).
2. Attach the lock nut and clevis assembly to the air cylinder (Figure 2).
3. Adjust the driver's seat to the far back position (Figure 3). Place the *BrakeBuddy* on the floorboard between the seat and the brake pedal. Slide the *BrakeBuddy* back against the seat for maximum working room.
4. Attach the clevis to the towed vehicle's brake pedal (Figure 4). With the notched end of the clevis facing up (stamped with the word "top"), attach the clevis to the top of the towed vehicle's brake pedal. Make sure to angle the brake pedal clevis so that the upper portion of the clevis grabs the top of the towed vehicle's brake pedal and then pull down on the air cylinder rod (or lower portion of the clevis) to extend the clevis under the bottom of the towed vehicle's brake pedal.

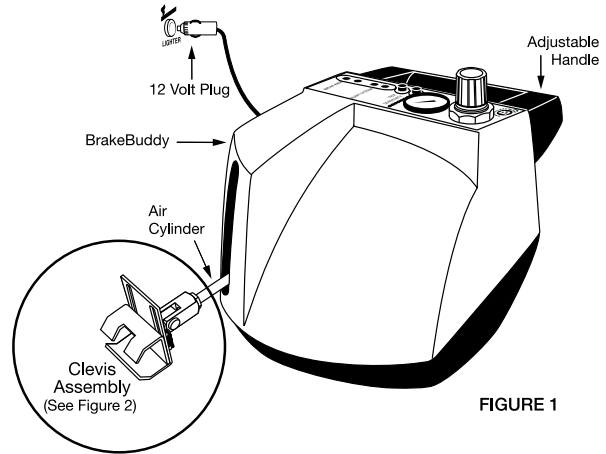

FIGURE 1

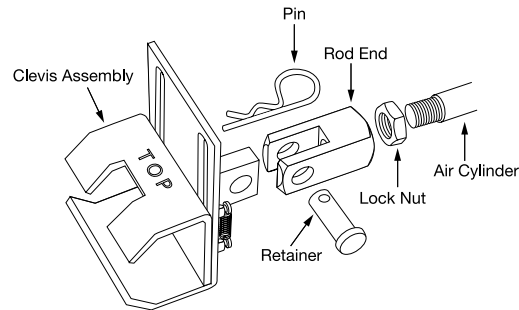

FIGURE 2

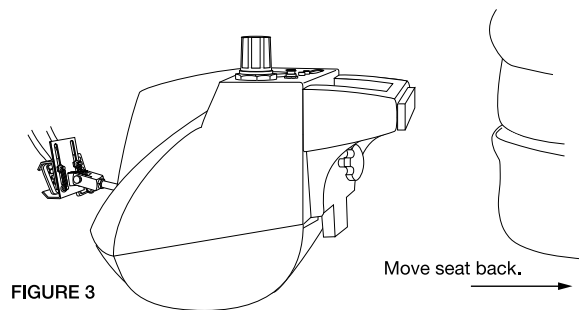

FIGURE 3

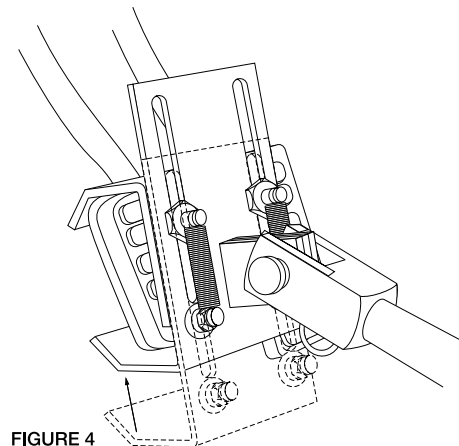

FIGURE 4



INSTRUCTION MANUAL

5. Move the **BrakeBuddy** forward until the air cylinder rod is fully retracted (Figure 5). Be sure the brake pedal is not depressed.
6. Adjust the driver's seat forward until it touches the handle on the back of the **BrakeBuddy** (Figure 6). If your vehicle has a drive-line disconnect, make sure it is out of the way to ensure the BrakeBuddy does not engage it while towing.
7. Adjust the **BrakeBuddy** handle (Figure 7). Loosen the adjustment knob on the back center portion of the BrakeBuddy and adjust the height of the handle so that the handle contacts the seat at the lowest position possible without sliding under the seat (the lower on the seat, the firmer the support). Tighten the adjustment knob to secure handle.
8. Power the **BrakeBuddy** (Figure 8). To power the **BrakeBuddy**, plug it into a 12v accessory receptacle in the towed vehicle. When powered, the air compressor will fill the air tank in 30-40 seconds. If a 12v power supply is not available in the towed position, a '12v Battery Direct Kit' is available.
9. Push the red 'Test' button located on top of your **BrakeBuddy** 3-5 times (Figure 9) to: (a) make sure the unit is working and adjusted properly; and (b) to remove the vacuum stored in the brake vacuum reservoir of the towed vehicle. **WARNING: Failure to drain the towed vehicle's brake vacuum every time you install the BrakeBuddy will result in excessive tire wear.**
10. Make final seat adjustment. After completing the above step (pushing Test button 3-5 times), the air cylinder extending and retracting will have placed the BrakeBuddy in the proper position. If there is a gap between the seat and handle adjust the seat forward to close the gap.

IMPORTANT: Look at the brake lights on the rear of the towed vehicle to make sure that they are not on. If the brake lights are on, the BrakeBuddy is too close to the brake pedal.

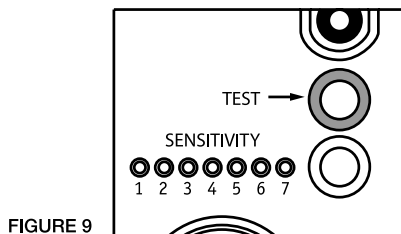
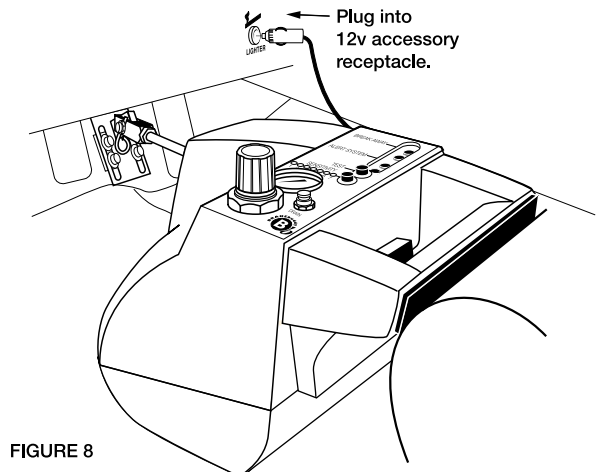
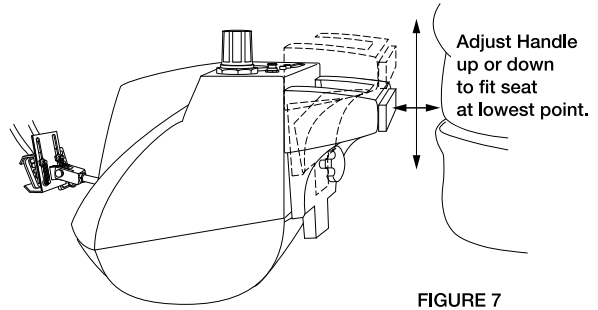
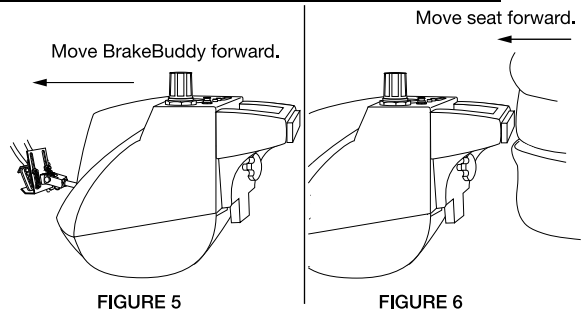



INSTRUCTION MANUAL

OPERATION INSTRUCTIONS

1. **Adjust the air regulator knob to match the weight of your towed vehicle** (Figure 10). The braking pressure, or how hard your towed vehicle will brake in tow, is adjusted by the air regulator on top of the *BrakeBuddy*. To find the correct pressure setting for your vehicle, please refer to the **Vehicle Weight Formula Chart** below. To adjust the setting, pull up on the air regulator knob, turn knob until the pressure gauge reads the correct setting specified by the Vehicle Weight Formula Chart, and push the knob down to lock it in place.

NOTE: The air gauge shows how much pressure is set to apply the brake; it does not display the air pressure inside the air tank that is automatically filled when the *BrakeBuddy* is plugged into the 12 volt receptacle.

When the *BrakeBuddy* engages, the towed vehicle should give a slight and smooth tug on the motorhome. If you do not feel a smooth tug, simply adjust the air regulator to increase the pressure until you feel the *BrakeBuddy* activate. **Note:** Larger motorhomes may not feel a tug when towing smaller vehicles. In this case, refer to the Vehicle Weight Formula chart. Also, for confirmation of when and how long the *BrakeBuddy* is activating, a wireless Alert System may be purchased.

2. **Adjust the Sensitivity Button.** The "Sensitivity" button on the top of the *BrakeBuddy* determines how hard you must apply the brakes in the motorhome before the *BrakeBuddy* will engage the brakes in your towed vehicle. The sensitivity of the *BrakeBuddy* is adjusted by holding down the Sensitivity button (Figure 10). The more lights that are illuminated, the easier the *BrakeBuddy* will activate. Each time the *BrakeBuddy* is installed, the sensitivity setting defaults to the middle sensitivity setting (four lights will be illuminated).

NOTE: Your RV must be moving faster than 15 mph for the *BrakeBuddy* to engage the brakes in the towed vehicle.

REMOVAL INSTRUCTIONS

To remove the *BrakeBuddy* from your towed vehicle: unplug the unit, push the drain button to relieve the air pressure in the system, adjust seat back and remove the *BrakeBuddy*.

CAUTION: Failure to drain your *BrakeBuddy*'s air system and unplug it from the car's power source before handling may cause damage to your vehicle, serious injury or death.

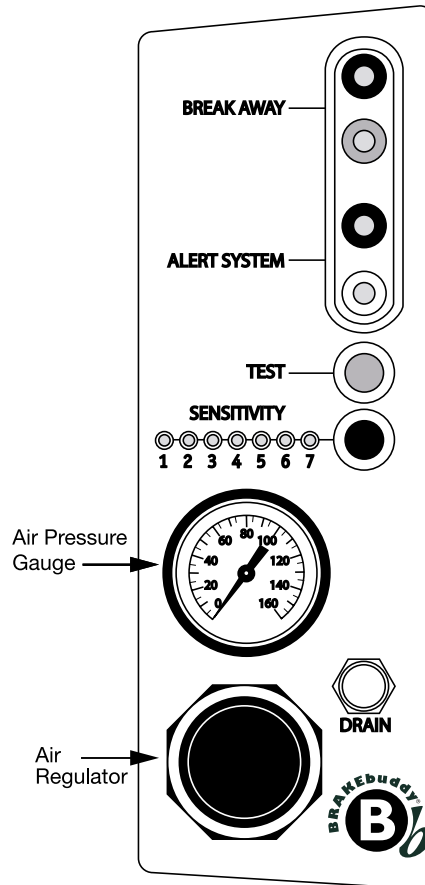

FIGURE 10

VEHICLE WEIGHT FORMULA

Settings are made by adjusting the air regulator knob. Lift up and turn the knob clockwise to increase pressure and counter-clockwise to decrease pressure.

1,500 – 2,000 Lbs.	25 PSI
2,000 – 2,500 Lbs.	35 PSI
2,500 – 3,000 Lbs.	45 PSI
3,000 – 3,500 Lbs.	50 PSI
3,500 – 4,000 Lbs.	55 PSI
4,000 – 4,500 Lbs.	65 PSI
4,500 – 5,000 Lbs.	75 PSI
Over 5,000 Lbs.	85 PSI

NOTE: 1999 and newer Jeep Grand Cherokees should be set at 55 PSI



INSTRUCTION MANUAL

TROUBLESHOOTING

- Problem:** The air compressor won't come on after I plug in the *BrakeBuddy*.
- Solution:** Check the air gauge for pressure in the tank. If the tank is already pressurized the compressor is designed not come on until the tank's pressure is reduced by BrakeBuddy activation. Make sure that there is power to the 12 volt receptacle and that the fuse for the 12 volt plug is functioning. If both are functioning, the green indicator light on the 12 volt plug will be lit when it is plugged in. To remove the 12 volt fuse on the BrakeBuddy's power cord, push in the silver tip of the cord, turn it counter-clockwise and pull out.
- Problem:** The *BrakeBuddy* won't apply the brakes in the towed vehicle.
- Solution:** Make sure the air regulator is properly adjusted for the weight of the towed vehicle. Also check the sensitivity setting. Remember, your RV must be moving for the BrakeBuddy to work.
- Problem:** The *BrakeBuddy* applies the brakes too hard in my towed vehicle.
- Solution:** Push the test button three to five times before towing to relieve the vacuum in the towed vehicle's brake booster. Reduce the air pressure.
- Problem:** The *BrakeBuddy* applies the brake as soon as I plug it in.
- Solution:** Check that the breakaway system is properly connected and the pin is plugged into the junction box. **Note:** *The breakaway system is a BrakeBuddy accessory.*
- Problem:** The compressor pumps up and then keeps on pumping slowly.
- Solution:** There may not be enough current to the *BrakeBuddy*. You may have a weak battery or you may need a '12v Battery Direct Kit'.
- Problem:** I have to apply the brakes in my motorhome very hard for the *BrakeBuddy* to come on.
- Solution:** Increase the sensitivity of the *BrakeBuddy* by pressing the sensitivity button.
- Problem:** The *BrakeBuddy* turns my brake lights on even though I am not applying the brakes in my motorhome.
- Solution:** The *BrakeBuddy* may be too close to the brake pedal thereby activating the brake light switch. See steps 9 & 10 of the installation instructions.

Master Concepts, Inc. thanks you for purchasing BrakeBuddy. A 3-year limited warranty and a 30-day money back guarantee apply to the BrakeBuddy® and BrakeBuddy accessories. We wish you safe and happy travels.



INSTRUCTION MANUAL

LIMITED THREE-YEAR WARRANTY

WHAT IS COVERED AND FOR HOW LONG

Congratulations on your recent purchase of your quality Master Concepts product. We are confident that our product will perform well and therefore warrant to you, as the original retail purchaser, for a period of three years from the date of original purchase, that your new product will be free of mechanical and electrical defects in material and workmanship.

WHAT MASTER CONCEPTS WILL DO & HOW TO GET SERVICE

During the warranty period, we will repair or replace your new product (at our option) without cost to you, which will be your exclusive remedy under this warranty. Please do not return this product to the place of purchase; doing so may delay the processing of your claim and our repair of your product. Simply return your product postage prepaid, with proof of purchase and a short description of the problem directly to our factory service center as the following address:

MASTER CONCEPTS, INC.
4371 PLATTE AVE
SEDALIA, CO 80135

WHAT IS NOT COVERED

Our warranty for your product will not cover damage resulting from neglect or misuse of the product, use of improper voltage or current, use contrary to operating instructions, or disassembly, repair, or alteration by any person other than an authorized service station. Any implied warranty of merchantability or fitness for a particular purpose of your product is limited to the duration of this written warranty. We shall not be liable for any incidental or consequential damages for breach of any express or implied warranty on your product.

HOW YOUR STATE'S LAWS MAY APPLY

Some states do not allow limitations on how long an implied warranty lasts or the exclusion or limitation of incidental or consequential damages, so the above limitation may not apply to you. This warranty gives you specific legal rights, and you may also have other rights, which vary from state to state.