

MOR/ryde Television Mounts



Installation Instructions for TV40-001

Thank you for choosing a MOR/ryde television mount. The TV40-001 is designed to mount flat panel televisions or monitors with VESA (Video Electronics Standards Association) hole patterns up to 200mm x 200mm* and weighing up to 50 lbs. It mounts to a horizontal surface, counter, or RV cabinet and allows for the television to extend 7" out from the installed position. In the out position the television can swivel $\pm 30^\circ$ (may vary with size of television or installed position). MOR/ryde's unique locking mechanism offers an easy way to keep your television safely in the out position or locked in for travel.

*A 200mm x 400mm adaptor plate is available through MOR/ryde customer service.

CAUTION: The size and weight of your television must be properly supported. The surface must be capable of supporting five times the weight of the television plus the mount. The structure of your RV may require additional reinforcement. MOR/ryde is responsible for the design and manufacturing of our parts; we are not responsible for the structure it is mounted to. Improper installation may cause property damage or personal injury. MOR/ryde cannot be liable for property damage or injury caused by incorrect mounting or incorrect use during travel or otherwise.

If you do not understand these directions, or have any doubts about the safety of the installation, please call MOR/ryde customer service at 866-990-7433. Our customer service representatives can assist you with installation questions and missing or replacement parts. Please call MOR/ryde before returning products to the point of purchase.

NOTE: This mount is not intended for use on brick, concrete, concrete block, or steel surfaces. It is up to the installer to verify the safety of any installation method or hardware that is not provided by or recommended by MOR/ryde. We make every effort to assure all necessary television mounting hardware is included. If the television mounting hardware you need is not included please consult your local hardware store or call MOR/ryde customer service.

SUPPLIED PARTS AND HARDWARE: Please note that you will not need all of the provided hardware to complete installation.

Hardware for mounting television: Refer to your television's owners manual or select the appropriate bolt from the hardware provided.

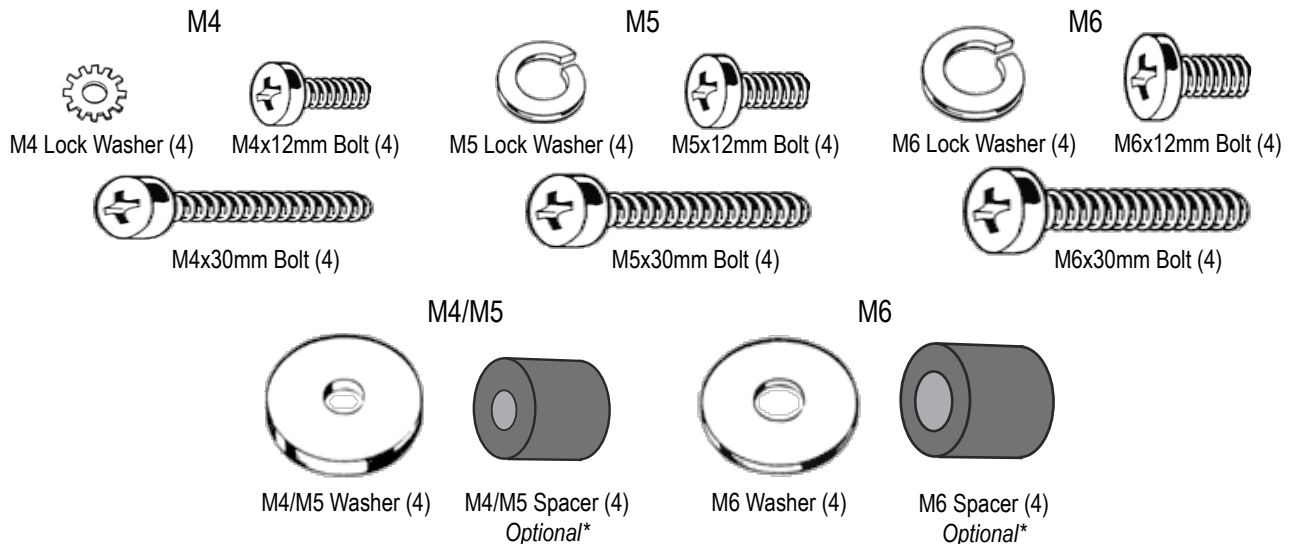

*Spacers are for televisions with recessed mounting holes.

Hardware for securing bracket: Select the appropriate length based on the thickness of your mounting surface.

< best for metal applications >

< best for wood applications >

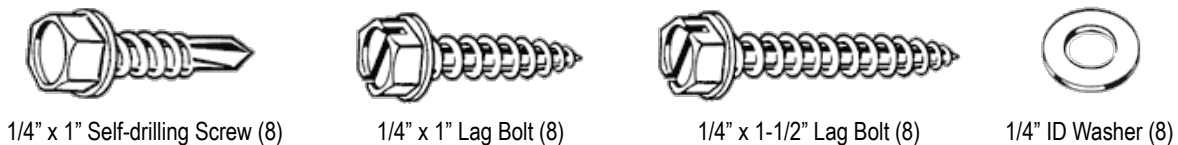

Prepare television for installation: If your television came with a stand, please remove the stand by referring to your television's owners manual and ensure the hardware has been removed from the mounting holes.

STEP 1 Assemble mount: Remove the bolt and lock nut¹ from the bracket arm² and slide through the base mount opening³ until the locking bar⁴ catches the front slot⁵ ("IN" position). Install the bolt and lock nut¹ back into the desired location (Option A or B below).

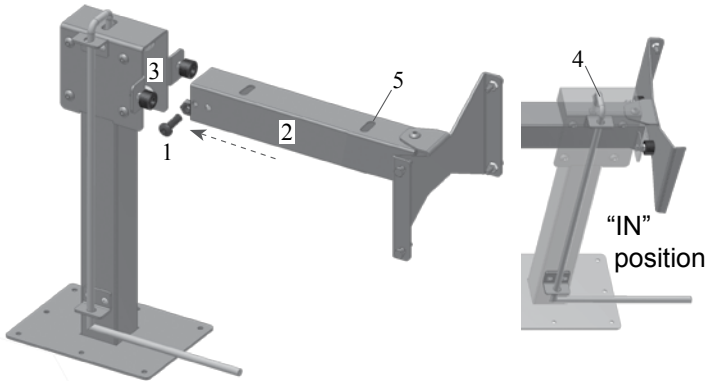

STEP 2 Secure the bracket to mounting surface: Pre-drill holes using a 1/8" drill bit for use with 1/4" lag bolts. Use lag bolts or self drilling screws (depending on your mounting surface) with 1/4" washers to secure base of bracket to the mounting surface.

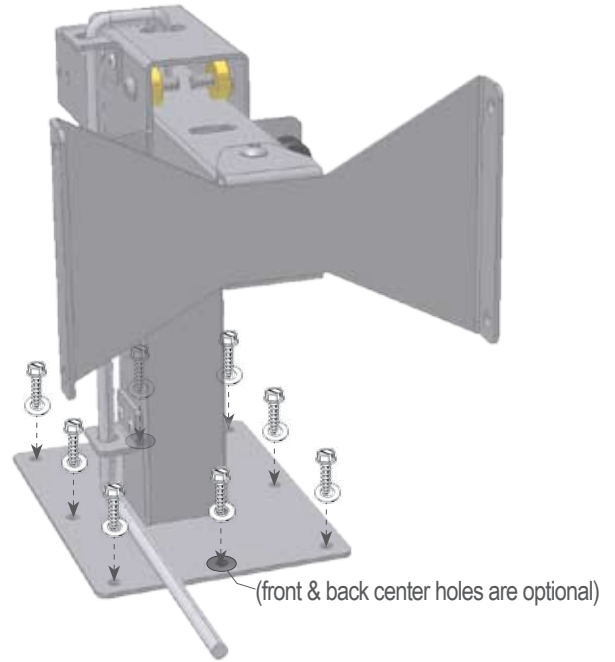

Option A: Placing the bolt in the back hole allows for the bracket arm to be locked into place in both the "OUT" and "IN" positions.

Option B: Placing the bolt in the front hole allows the TV to move freely in the "OUT" position and only lock in the "IN" position.

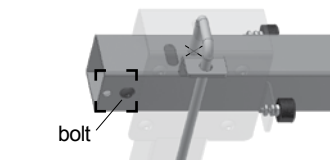
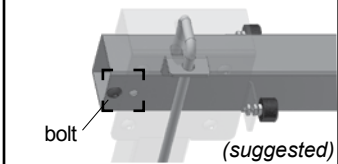

CAUTION: Using a screw or bolt length that is too long for your application may result in puncturing exterior structure.

STEP 3 Secure the television to mounting plate: Line up the hole pattern on your television with the matching hole pattern on the universal mounting plate as close to the center as possible. Using the appropriate mounting hardware, washers, and optional spacers, secure the television to the mounting plate.

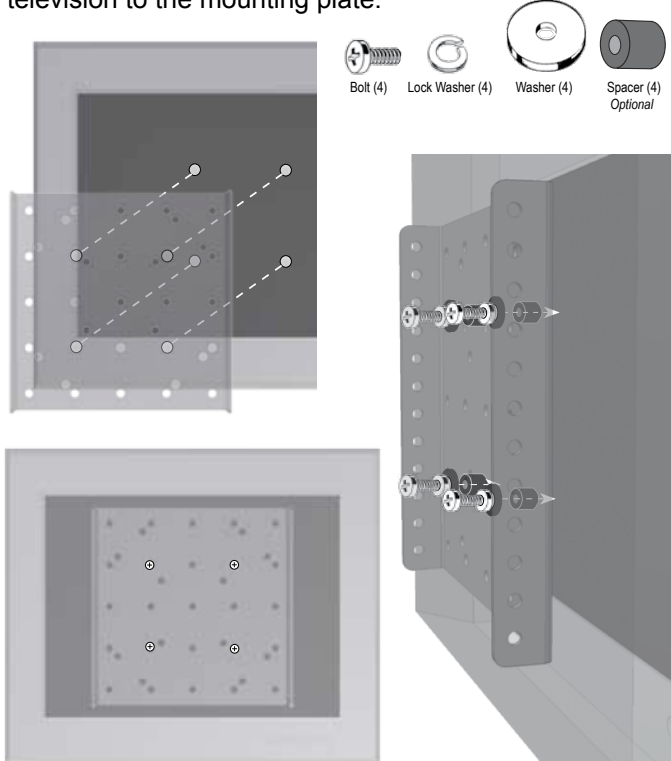

STEP 4 Secure mounting plate with television to bracket arm: Loosely secure the mounting plate - with the television attached - to the bracket arm. Adjust height for television size and tighten bolts to hold in place.

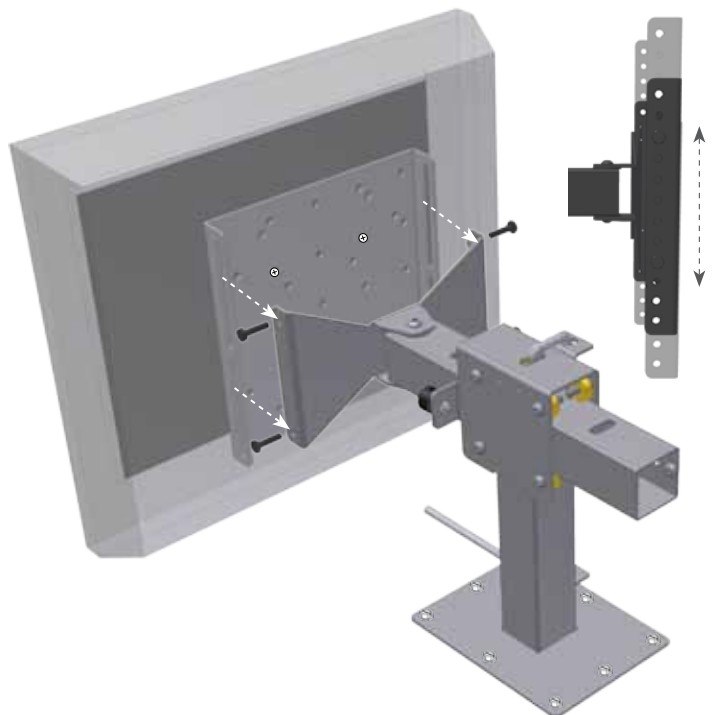

CAUTION: This step may require two people to lift the television onto the bracket arm and secure. MOR/ryde is not responsible for property damage and/or personal injury.